

[54] **OVER WRITE CAPABLE
MAGNETOOPTICAL RECORDING
MEDIUM**

4,771,347 9/1988 Horimai et al. 360/59
4,794,560 12/1988 Bell et al. 360/59

[75] **Inventors:** Jun Saito, Tokyo; Masatoshi Sato, Machida; Hiroyuki Matsumoto, Tokyo, all of Japan

OTHER PUBLICATIONS

Tsunashima et al, "Thermo. writing on exchange-coupled amorphous rear-earth iron double-layer films", IEEE Trans. on MAG, vol. MAG-17, No. 6, Nov. 1981.

[73] **Assignee:** Nikon Corporation, Tokyo, Japan

R. G. Swartz and B. A. Wooley, "The Bell System Technical Journal", 1983, vol. 62, pp. 1923-1936.

[21] **Appl. No.:** 192,764

[22] **Filed:** May 10, 1988

Primary Examiner—Steven L. Stephan

Assistant Examiner—Hoa T. Nguyen

Attorney, Agent, or Firm—Shapiro and Shapiro

[30] **Foreign Application Priority Data**

May 18, 1987 [JP] Japan 62-120642

[51] **Int. Cl.⁴** G11B 5/66

[52] **U.S. Cl.** 360/131; 369/13; 365/122

[58] **Field of Search** 369/13; 360/131, 135, 360/59, 114; 365/122

[57] **ABSTRACT**

Over Write Capable Magneto-optical Recording Medium, Recording Method and Apparatus Using the Same. The recording medium in which the direction of an initial field H_{ini} is the same as that of a bias field H_b (Classes 1, 2, and 8 in Table 1), and which satisfies predetermined formulas can allow an over-write operation if a jointing field H_{joint} is used which continuously changes from the initial field H_{ini} to the bias field H_b.

[56] **References Cited**

U.S. PATENT DOCUMENTS

4,126,494 11/1978 Imamura et al. 365/122
4,645,722 2/1987 Katayama et al. 365/122
4,649,519 3/1987 Son et al. 365/122

3 Claims, 14 Drawing Sheets

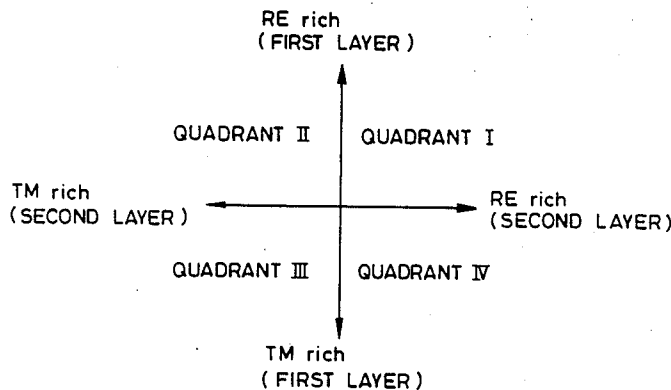
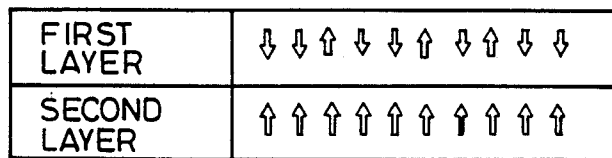

FIG. 1

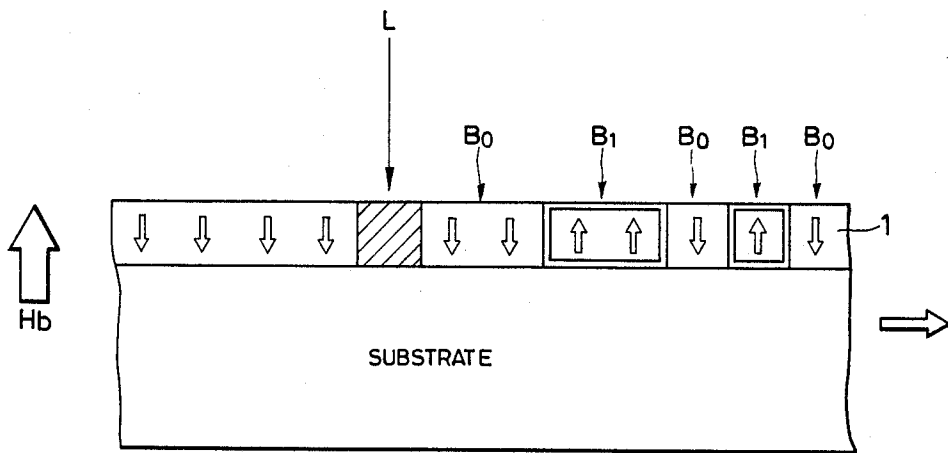

FIG. 2

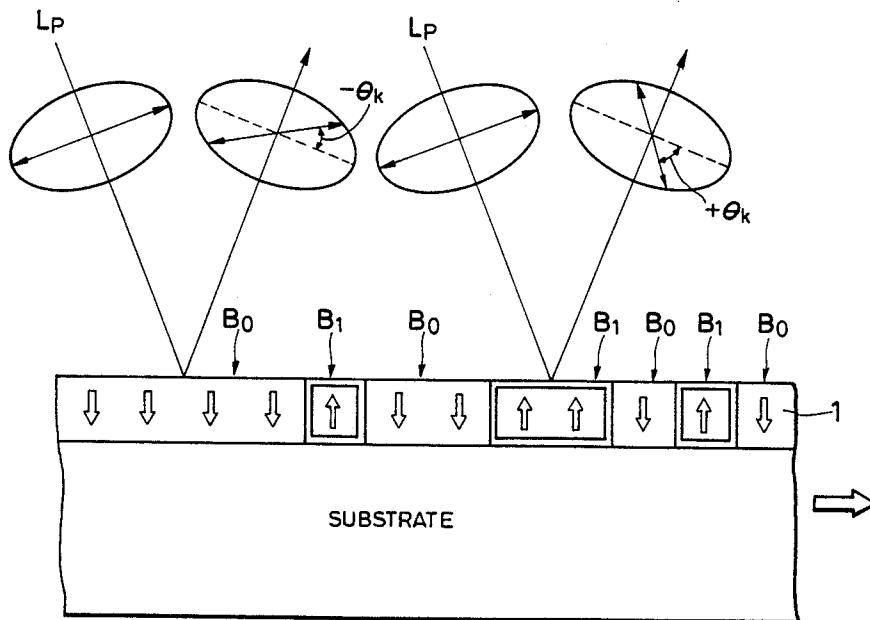

FIG. 3

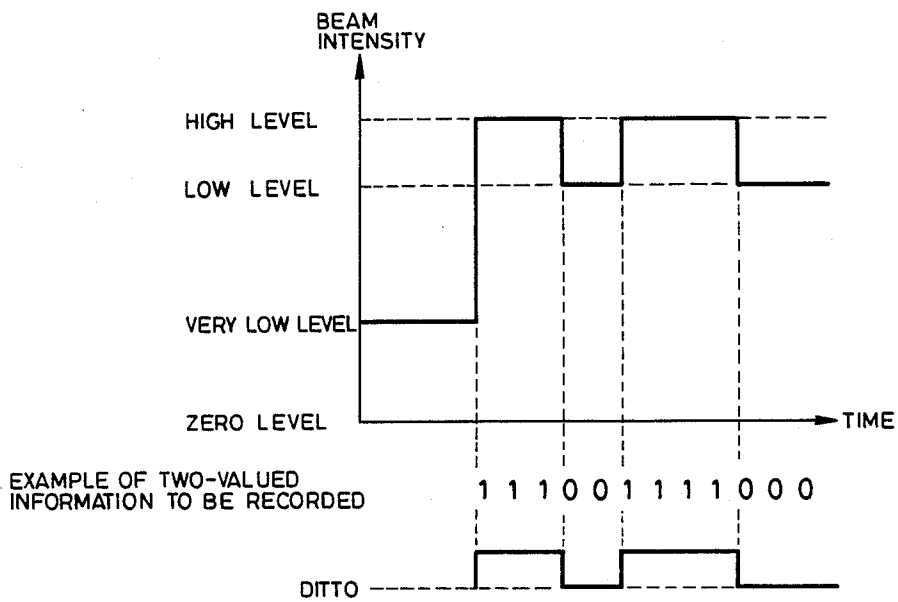

FIG. 4

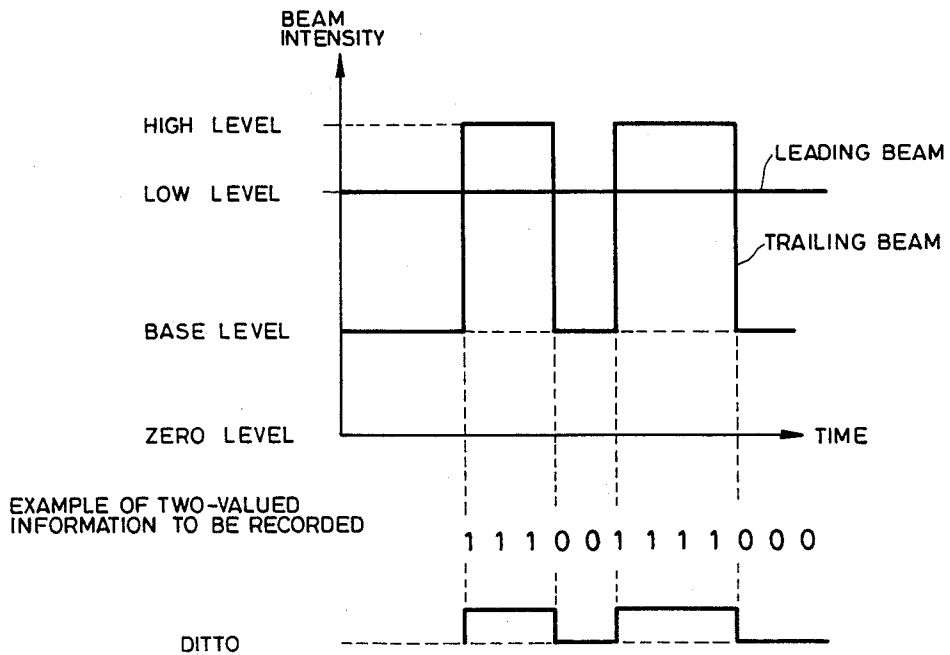

FIG. 5A

FIRST LAYER : RECORDING LAYER
SECOND LAYER: REFERENCE LAYER

FIG. 5B

FIRST LAYER	↓ ↓ ↑ ↓ ↓ ↓ ↑ ↓ ↓ ↓
SECOND LAYER	↑ ↑ ↑ ↑ ↑ ↑ ↑ ↑ ↑ ↑

FIG. 6

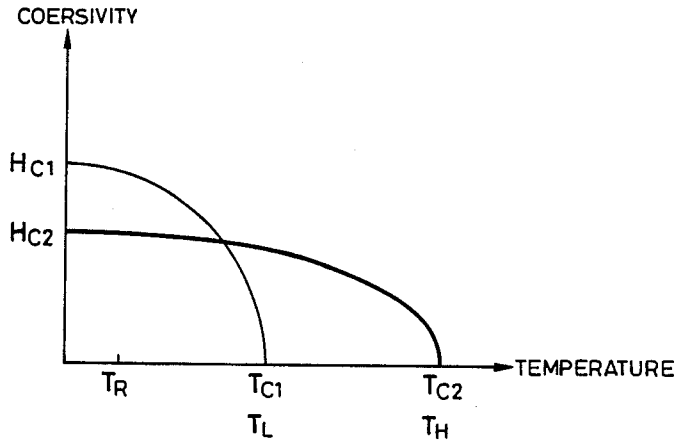

FIG. 7

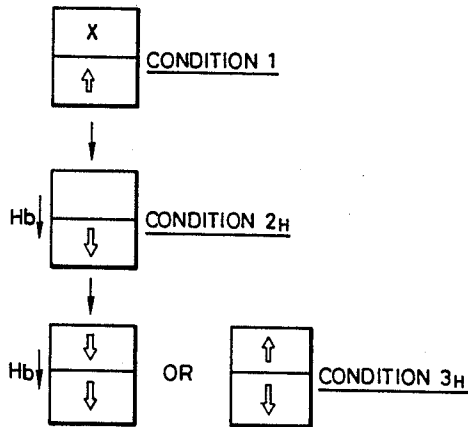

FIG. 8

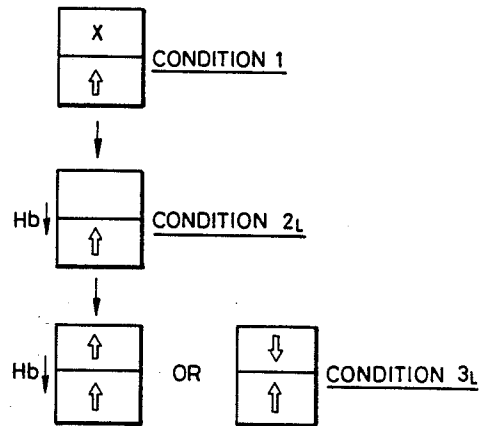

FIG. 9

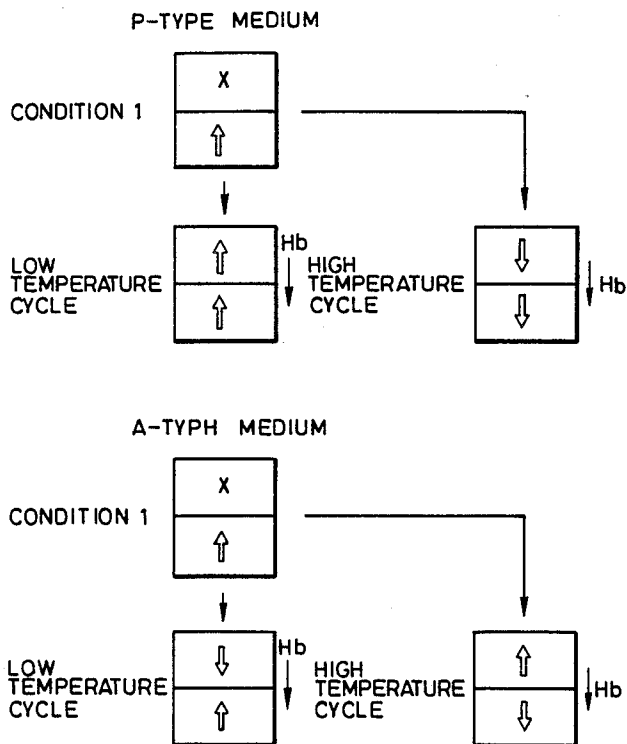

FIG. 10

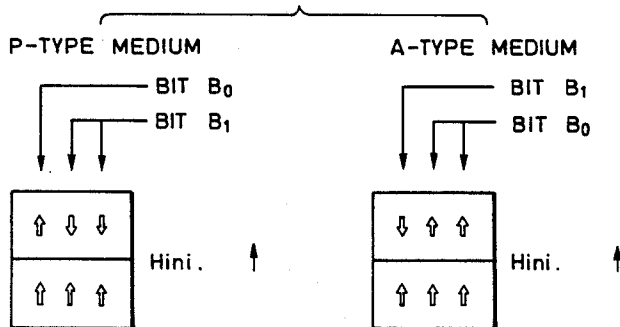

FIG. 11

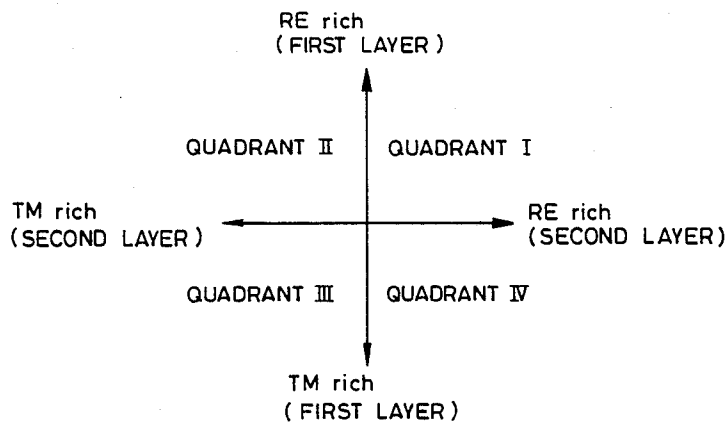

FIG. 13

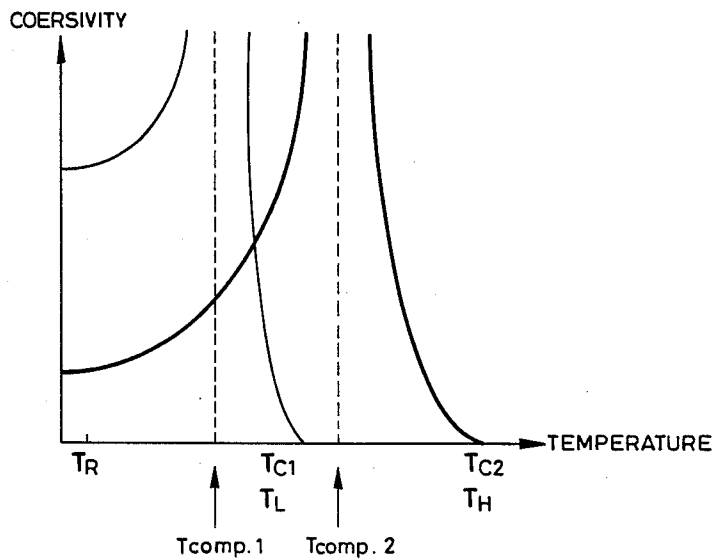

FIG. 12A

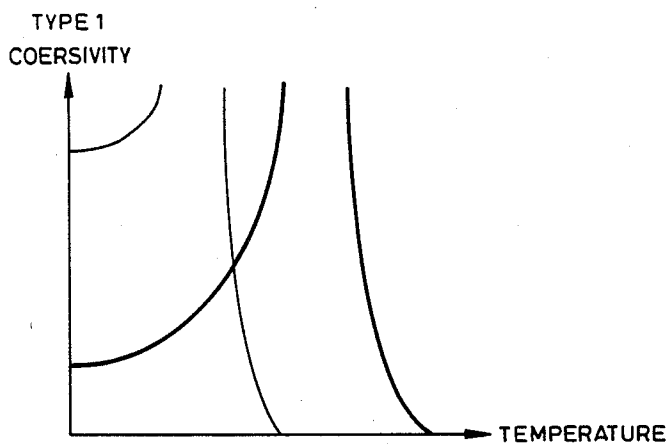

FIG. 12B

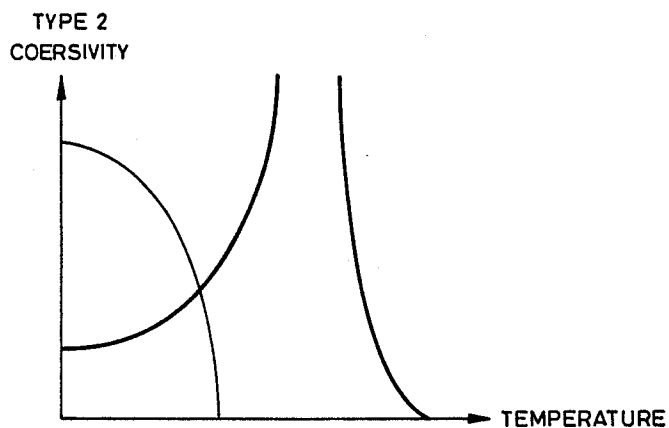

FIG. 12C

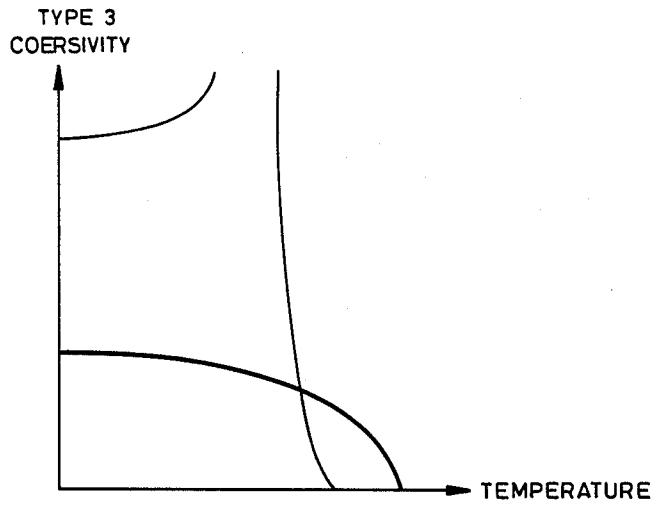

FIG. 12D

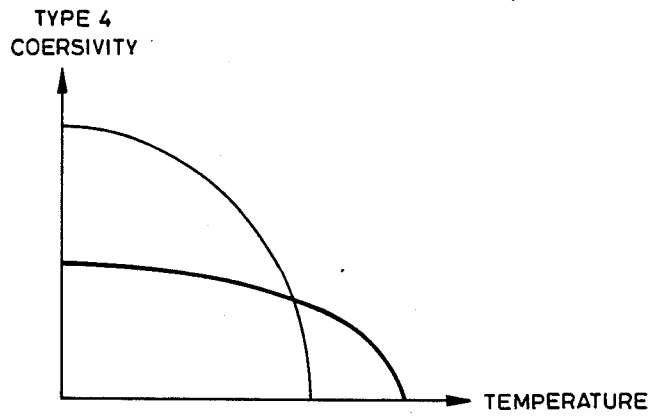

FIG. 14

FIG. 15

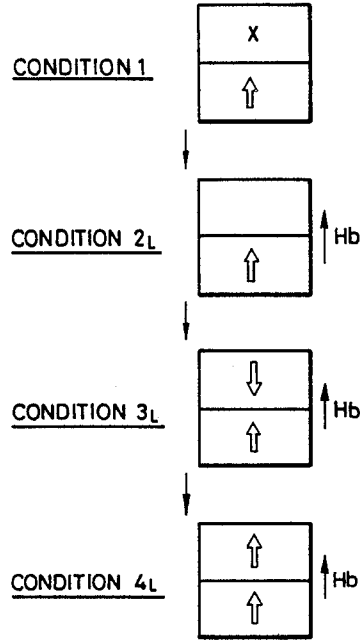
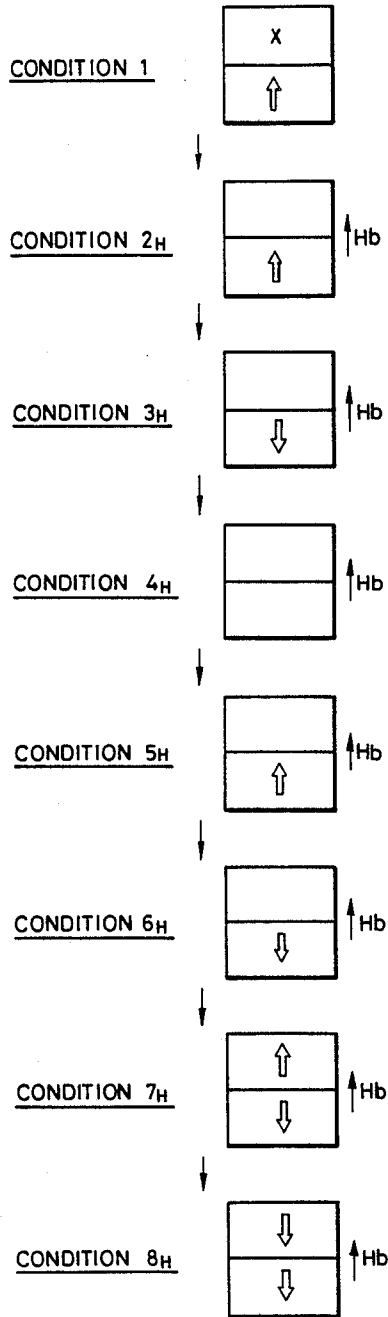

FIG. 16

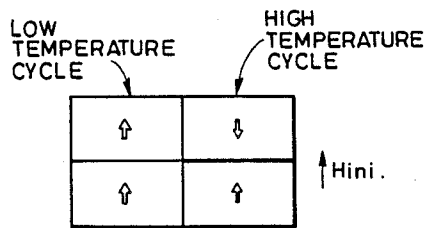

FIG. 18

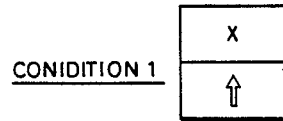

FIG. 17

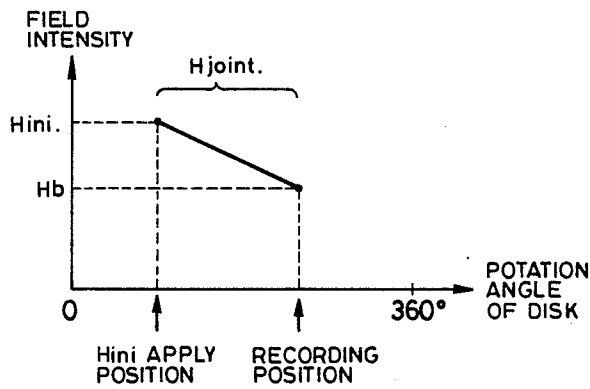

FIG. 19

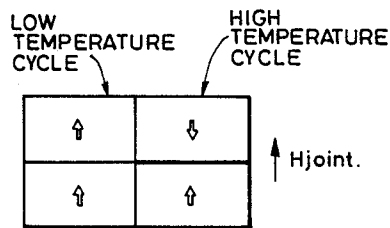

FIG. 20

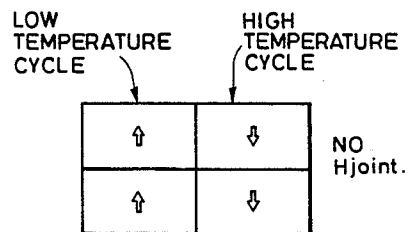

FIG. 21

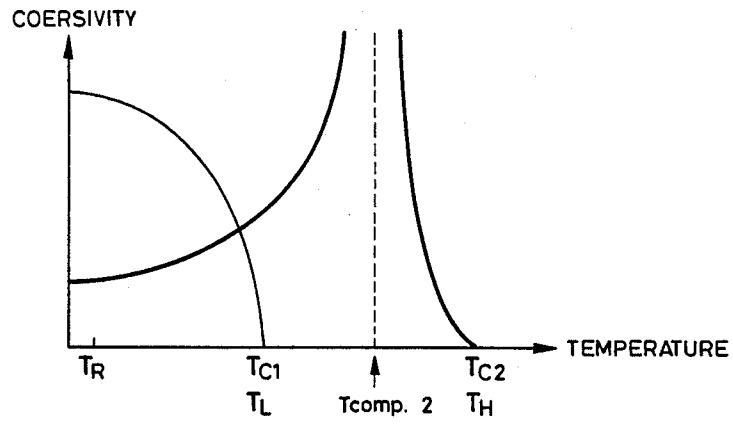

FIG. 24

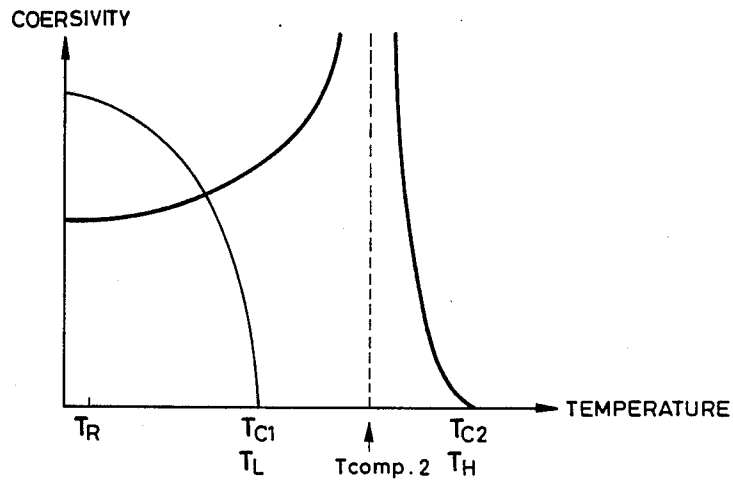

FIG. 22

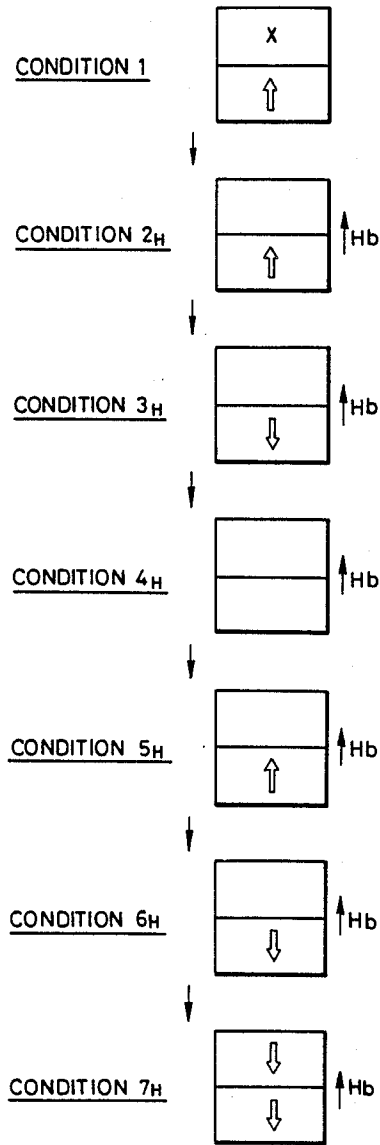

FIG. 23

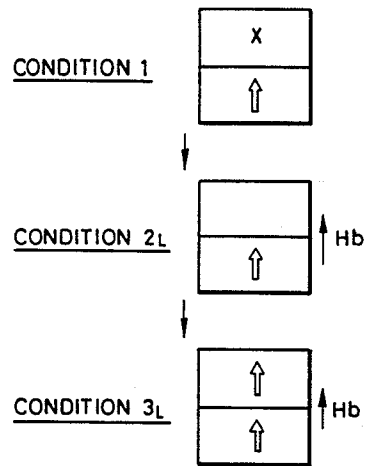

FIG. 25

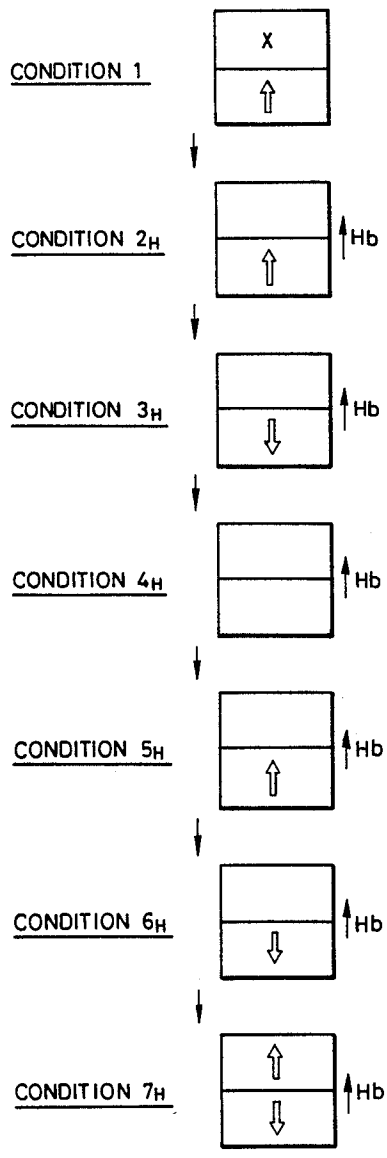

FIG. 26

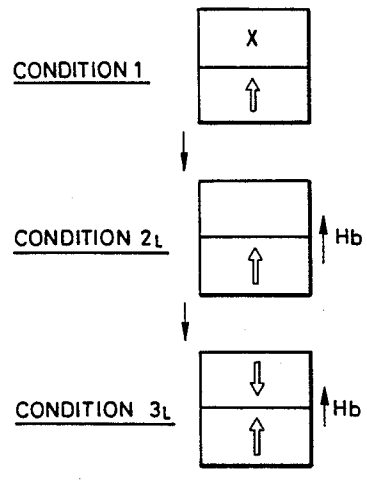

FIG. 27

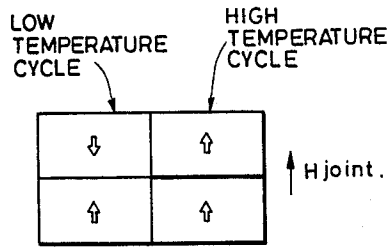

FIG. 28

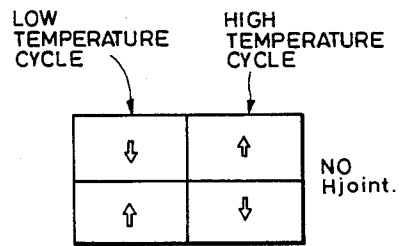

FIG. 29

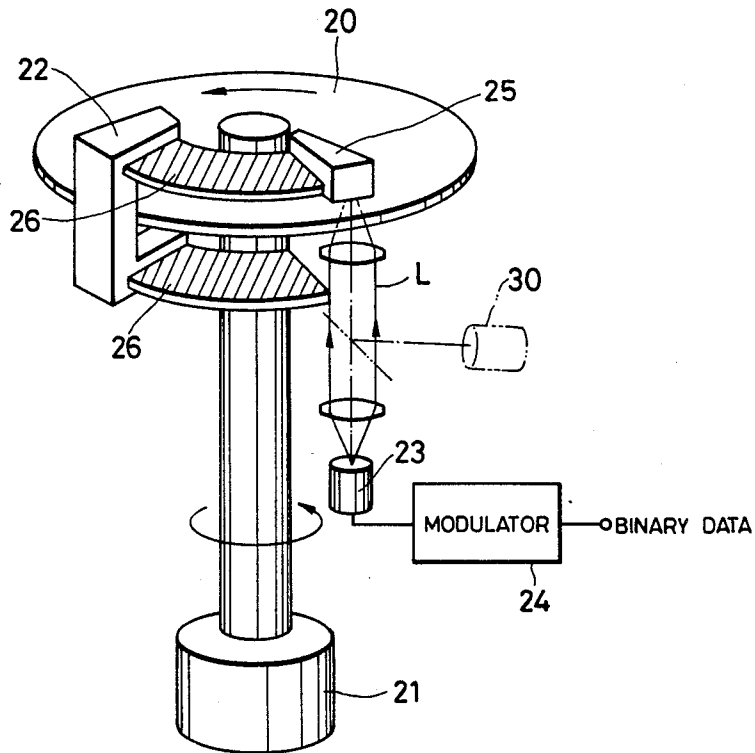

FIG. 30

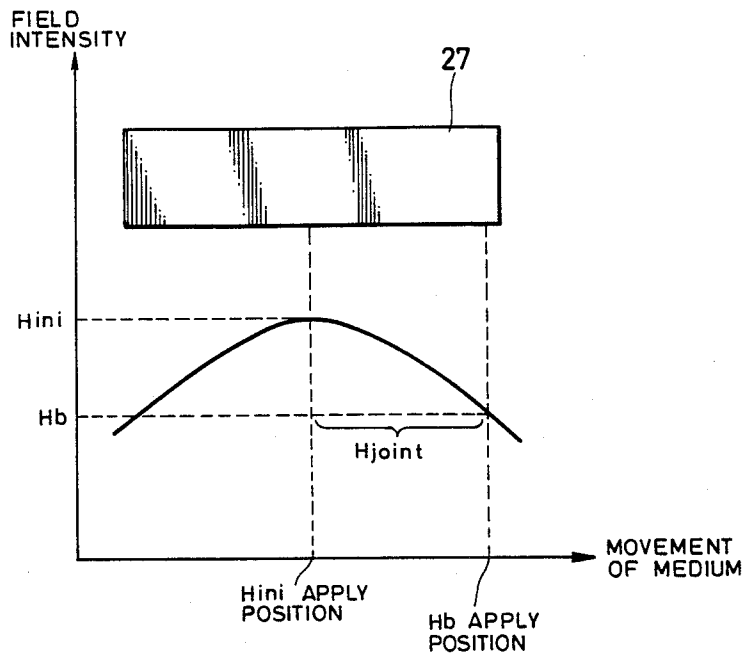
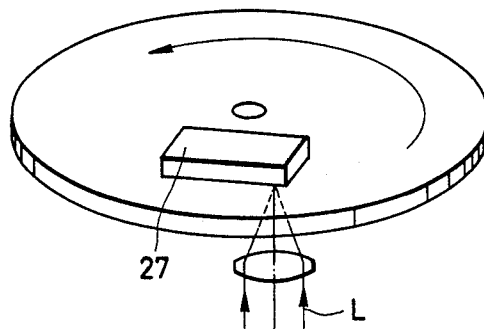

FIG. 31



OVER WRITE CAPABLE MAGNETOOPTICAL RECORDING MEDIUM

BACKGROUND OF THE INVENTION

1. Field of the Invention

The present invention relates to an over write capable magneto-optical recording medium, and a recording method and apparatus and a reproduction method and apparatus using the same.

2. Related Background Art

In recent years, many efforts have been made to develop an optical recording/reproduction method, an optical recording apparatus and a medium used therefor, which can satisfy various requirements including high density, large capacity, high speed access, and high recording/reproduction speed.

Of various optical recording/reproduction methods, the magneto-optical recording/reproduction method is most attractive due to its unique advantages that information can be erased after use and new information can be written thereon.

A recording medium used in a magneto-optical recording/reproduction method has a perpendicular magnetic layer or layers as a recording layer. The magnetic layer comprises, for example, amorphous GdFe, GdCo, GdFeCo, TbFe, TbCo, TbFeCo, and the like. Concentric or spiral tracks are formed on the recording layer, and data is recorded on the tracks. Note that in this specification, one of the "upward" and "downward" directions of magnetization with respect to a film surface is defined as an "A direction" and the other one is defined as a "non-A direction". Data to be recorded is binarized in advance, and is recorded by a bit (B₁) having "A-directed" magnetization and a bit (B₀) having "non-A-directed" magnetization. These bits B₁ and B₀ correspond to "1" and "0" levels of a digital signal, respectively. However, in general, the direction of magnetization of the recording tracks can be aligned in the "non-A direction" by applying a strong bias field before recording. This processing is called "initialization". Thereafter, the bit (B₁) having "A-directed" magnetization is formed on the tracks. Data is recorded in accordance with the presence/absence and/or a bit length of the bit (B₁).

Principle of Bit Formation

In the bit formation, a characteristic feature of laser, i.e., excellent coherence in space and time, is effectively used to focus a beam into a spot as small as the diffraction limit determined by the wavelength of the laser light. The focused light is radiated onto the track surface to write data by producing bits less than 1 μm in width on the recording layer. In the optical recording, a recording density up to 10⁸ bit/cm² can be theoretically attained, since a laser beam can be concentrated into a spot with a size as small as its wavelength.

As shown in FIG. 1, in the magneto-optical recording, a laser beam L is focused onto a recording layer 1 to heat it, while a bias field (H_b) is externally applied to the heated portion in the direction opposite the initialized direction. A coercivity H_c of the locally heated portion is decreased below the bias field (H_b). As a result, the direction of magnetization of that portion is aligned in the direction of the bias field (H_b). In this way, reversely magnetized bits are formed.

Ferromagnetic and ferrimagnetic materials differ in the temperature dependencies of the magnetization and

H_c. Ferromagnetic materials have H_c which decreases around the Curie temperature and allow data recording based on this phenomenon. Thus, data recording in ferromagnetic materials is referred to as T_c recording (Curie temperature recording).

On the other hand, ferrimagnetic materials have a compensation temperature, below the Curie temperature, at which magnetization (M) becomes zero. The H_c abruptly increases around this temperature and hence abruptly decreases outside this temperature. The decreased H_c is cancelled by a relatively weak bias field (H_b). Namely, recording is enabled. This process is called T_{comp} recording (compensation point recording).

In this case, however, there is no need to adhere to the Curie point or temperatures therearound, and the compensation temperature. In other words, if a bias field (H_b) capable of cancelling a decreased H_c is applied to a magnetic material having the decreased H_c at a predetermined temperature higher than a room temperature, recording is enabled.

Principle of Reading

FIG. 2 illustrates the principle of data reading based on the magneto-optical effect. Light is an electromagnetic wave with an electromagnetic-field vector normally emanating in all directions in a plane perpendicular to the light path. When light is converted to linearly polarized beams (L_p) and radiated onto a recording layer (1), it is reflected by or passes through the recording layer (1). At this time, the plane of polarization rotates according to the direction of magnetization (M). This phenomenon is called the magnetic Kerr effect or magnetic Faraday effect.

For example, if the plane of polarization of the reflected light rotates through θ_k degrees for "A-directed" magnetization, it rotates through -θ_k degrees for the "non-A-directed" magnetization. Therefore, when the axis of an optical analyzer (polarizer) is set perpendicular to the plane inclined at -θ_k, the light reflected by "non-A-direction" magnetized bit (B₀) cannot pass through the analyzer. On the contrary, a product (X sin 2θ_k)² of the light reflected by a bit (B₁) magnetized along the "A direction" passes through the analyzer and becomes incident on a detector (Photoelectric conversion means). As a result, the bit (B₁) magnetized along the "A direction" looks brighter than the bit (B₀) magnetized along the "non-A-direction", and the detector produces a stronger electrical signal for the bit (B₁). The electrical signal from the detector is modulated in accordance with the recorded data, thus reading the data.

In order to re-use a recorded medium, (i) the medium must be re-initialized by an initializing device, (ii) an erasing head as well as a recording head must be added to a recording apparatus, or (iii) recorded data must be erased using a recording apparatus or an erasing apparatus as preliminary processing.

Therefore, in the conventional magneto-optical recording method, an over-write operation, which allows new data recording regardless of the presence/absence of the recorded data, is impossible.

If the direction of a bias field (H_c) can be freely changed between the "A direction" and "non-A direction", an over-write operation is possible. However, the direction of the bias field (H_b) cannot be changed at high speed. For example, when a bias field (H_b) apply

means is a permanent magnet, the direction of the magnet must be mechanically reversed. In this case, it is impossible to rotate the direction of the magnet at high speed. Similarly, when the bias field (H_b) apply means is an electromagnet, the direction of such a large current cannot be reversed at high speed.

For this reason, a magneto-optical recording medium and a recording method using the same, capable of an over-write operation upon modulation of light without turning on/off a bias field (H_b) or changing the direction of the bias field (H_b) have been developed, and filed as U.S. Ser. No. 870,350 on June 4, 1986.

According to this prior patent application, there is provided a magneto-optical recording method, in which data is recorded on a recording layer of a magneto-optical recording medium using a bit having upward-magnetization and a bit having downward-magnetization, the method comprising the steps of:

(a) using, as the medium, a multilayered magnetic recording medium consisting of a first layer having a perpendicular magnetic anisotropy acting as a recording layer, and a second layer having a perpendicular magnetic anisotropy acting as a reference layer;

(b) moving said medium;

(c) applying an initial field so that, before recording, the direction of magnetization of the recording layer is left unchanged, and that of the reference layer is aligned either upward or downward;

(d) radiating a laser beam onto the medium;

(e) pulse modulating an intensity of the laser beam in accordance with binary data to be recorded;

(f) when the laser beam is radiated, applying a bias field to the irradiated portion; and

(g) when the intensity of the pulse-modulated laser beam is at high level, forming one of the bit having upward-magnetization and that having downward-magnetization, and when the intensity of the pulse-modulated laser beam is at low level, forming the other bit.

With the method of the prior application, the laser beam is pulse modulated based on data to be recorded. However, this procedure itself has been performed in the conventional magneto-optical recording method, and a means for pulse modulating the beam intensity based on two-valued or binary data to be recorded is a known means. For example, see "THE BELL SYSTEM TECHNICAL JOURNAL", Vol. 62 (1983) pp. 1923-1936.

A characteristic feature of the prior application lies in high and low levels of the beam intensity. More specifically, when the beam intensity is at high level, "A-directed" magnetization of the reference layer is reversed to the "non-A direction" by means of a bias field (H_b), and a bit having the "non-A-directed" (or "A-directed") magnetization is thus formed in the recording layer by means of the "non-A-directed" magnetization of the reference layer. When the beam intensity is at low level, a bit having the "A-directed" (or "non-A-directed") magnetization is formed in the recording layer by means of the "A-directed" magnetization of the reference layer. If required high and low levels are given, it is easy for a person skilled in the art to modulate the beam intensity according to the prior application only by partially modifying the modulating means.

In this specification, if expressions 000 (or xxx) appear, 000 outside the parentheses in the first expression corresponds to 000 in the subsequent expressions 000 (or xxx), and vice versa.

As is well known, even if recording is not performed a laser beam is often turned on at very low level* in order to, for example, access a predetermined recording position on the medium. When the laser beam is also used for reading, the laser beam is often turned on at an intensity of the very low level*. In this invention, the intensity of the laser beam may be set at this very low level. However, low level for forming a bit is higher than the very low level*. Therefore, the output waveform of the laser beam of the prior application is as shown in FIG. 3.

In the prior application, a single beam is used. As described in U.S. Ser. No. 104,421 filed on Oct. 5, 1987, two proximity beams, i.e., a leading beam of low level and a trailing beam of high level are used. In this application, the leading beam is not modulated in the principle, and the trailing beam is modulated in accordance with data, thus allowing an over-write operation. In this case, the trailing beam is pulse-modulated between high level and base level (level equal to or lower than low level, and an output may be zero). The output waveform in this case is as shown in FIG. 4.

The multilayered magneto-optical recording medium of the prior application includes a first layer having a perpendicular magnetic anisotropy as a recording layer, and a second layer having a perpendicular magnetic anisotropy as a reference layer.

The invention of the prior application is divided into first and second aspects. In both the aspects, the recording medium has a multilayered structure, which is divided into two layers, as shown in FIG. 5A.

The first layer is the recording layer, which exhibits high coercivity at room temperature and has low reversing temperature. The second layer is the reference layer, which exhibits low coercivity at room temperature and has a higher reversing temperature than the first layer. Both the layers comprise perpendicular magnetic layers. Note that each of the first and second layers can comprise a multilayered structure. If necessary, a third layer can be interposed between the first and second layers. In addition, a clear boundary between the first and second layers need not be formed, and one layer can be gradually converted into the other layer.

In the first aspect, the coercivity of a recording layer (first layer) is represented by H_{C1}; that of a reference layer (second layer) H_{C2}; the Curie temperature of the first layer, T_{C1}; that of the second layer, T_{C2}; the room temperature, T_R; the temperature of the recording medium when a low level laser beam is radiated, T_L; that when a high level laser beam is radiated, T_H; a coupling field applied to the first layer, H_{D1}; and a coupling field applied to the second layer, H_{D2}. In this case, the recording medium satisfies the following Formula 1, and satisfies Formulas 2 to 5 at the room temperature.

$$T_R < T_{C1} \approx T_L < T_{C2} \approx T_H \quad \text{Formula 1}$$

$$H_{C1} > H_{C2} + |H_{D1} \mp H_{D2}| \quad \text{Formula 2}$$

$$H_{C1} > H_{D1} \quad \text{Formula 3}$$

$$H_{C2} > H_{D2} \quad \text{Formula 4}$$

$$H_{C2} + H_{D2} < |H_{ini}| < H_{C1} \pm H_{D1} \quad \text{Formula 5}$$

In the above formula, symbol "≈" means "equal to" or "substantially equal to". In addition, of double signs ± and ∓, the upper sign corresponds to an A (antiparallel) type medium, and the lower sign corresponds to a

P (parallel) type medium (these media will be described later). Note that the P type medium includes a ferromagnetic material and a magnetostatic coupling medium.

The relationship between the coersivity and the temperature is as shown in the graph of FIG. 6. Referring to FIG. 6, the thin curve represents the characteristics of the first layer and the bold curve represents those of the second layer.

Therefore, when an initial field (H_{ini}) is applied to the recording medium at room temperature, the direction of magnetization of the second layer is reversed without reversing that of the first layer, according to Formula 5. When the initial field (H_{ini}) is applied to the recording layer before recording, the second layer can be magnetized in the "direction" (in the drawings, the "A direction" is indicated by an upward arrow " \uparrow ", and the "non-A direction" is indicated by a downward arrow " \downarrow "). If the initial field (H_{ini}) is decreased to zero, the direction of magnetization " \uparrow " of the second layer can be left unchanged without being re-reversed, according to Formula 4.

FIG. 5B schematically shows a state wherein only the second layer is magnetized in the "A direction" " \uparrow " immediately before recording.

Referring to FIG. 5B, the direction of magnetization in the first layer represents previously recorded data. Since the direction of magnetization in the first layer 1 does not change the basic operation mechanism, it is indicated by X in the following description. The table in FIG. 5B is modified as shown in Condition 1 in FIG. 7 for the sake of simplicity.

In Condition 1, the high-level laser beam is radiated onto the recording medium to increase the medium temperature to T_H . Since T_H is high than the Curie temperature T_{C1} , magnetization of the first layer 1 disappears. In addition, since T_H is near the Curie temperature T_{H2} , magnetization of the second layer 2 also disappears completely or almost completely. The bias field (H_b) in the "A direction" or "non-A direction" is applied to the medium in accordance with the type thereof. The bias field (H_b) can be a stray field from the medium itself. For the sake of simplicity, assume that the bias field (H_b) in the "non-A direction" is applied to the medium. Since the medium is moving, a given irradiated portion is immediately separated from the laser beam and is cooled by air. When the temperature of the medium is decreased under the presence of the field H_b , the direction of magnetization of the second layer is reversed to the "non-A direction" based on the field H_b (Condition 2 $_H$ in FIG. 7).

When the medium is further cooled and the medium temperature is decreased below T_{C1} , magnetization of the first layer appears again. In this case, the direction of magnetization of the first layer is influenced by that of the second layer due to a magnetic coupling (exchange or magnetostatic coupling) force. As a result, magnetization " \downarrow " (the P type medium) or " \uparrow " (the A type medium) is formed in accordance with the type of the medium, as shown in Condition 3 $_H$ in FIG. 7.

A change in conditions due to high-level laser beam irradiation is called a high-temperature cycle herein.

Next, in Condition 1 in FIG. 8, the low-level laser beam is radiated onto the medium to increase the medium temperature to T_L . Since T_L is near the Curie temperature T_{C1} , magnetization of the first layer disappears completely or almost completely. However, since T_L is below the Curie temperature T_{C2} , magnetization

of the second layer does not disappear (Condition 2 $_L$ in FIG. 8). In Condition 2 $_L$, although the bias field (H_b) is unnecessary, it cannot be turned on or off at high speed. Therefore, the bias field (H_b) is left applied inevitably.

However, since the coersivity H_{C2} is maintained high, the direction of magnetization of the second layer will not be reversed due to the field H_b . Since the medium is moving, a given irradiated portion is immediately separated apart from the laser beam and is cooled by air. As cooling progresses, magnetization of the first layer appears. The direction of magnetization is influenced by that of the second layer due to the magnetic coupling force. As a result, magnetization " \downarrow " (the P type medium) or " \uparrow " (the A type medium) appears in accordance with the type of the medium, his magnetization is not changed even at the room temperature (Condition 3 $_L$ in FIG. 8).

A change in conditions due to low-level laser beam irradiation is called a low-temperature cycle herein.

FIG. 9 summarizes the above descriptions. Referring to FIG. 9, bits, having either magnetization " \uparrow " or " \downarrow ", which are opposite to each other, are formed in the high- and low-temperature cycles regardless of the direction of magnetization in the first layer. More specifically, an over-write operation is enabled by pulse modulating the laser beam between high level (high-temperature cycle) and low level (low-temperature cycle) in accordance with data to be recorded.

Note that the recording medium normally has a disk shape, and is rotated during recording. For this reason, a recorded portion (bit) is again influenced by the initial field (H_{ini}), which is applied by initial field apply means during a single rotation. As a result, the direction of magnetization of the second layer is aligned along the original "A direction" " \uparrow " as shown in FIG. 10. However, at the room temperature, magnetization of the second layer can no longer influence that of the first layer, and the recorded data can be held.

If linearly polarized light is radiated onto the first layer, since light reflected thereby includes data, data can be reproduced as in the conventional magneto-optical recording medium.

A perpendicular magnetic film constituting the first (recording) layer and the second (reference) layer is selected from the group consisting of (1) crystalline or amorphous ferromagnetic or ferrimagnetic materials having the Curie temperature an no compensation temperature, and (2) crystalline or amorphous ferrimagnetic materials having both the compensation temperature and the Curie temperature.

The first aspect utilizing the Curie temperature has been described. In contrast to this, the second aspect of the present invention utilizes decreased coersivity H_C at a predetermined temperature exceeding the room temperature. The second aspect uses a temperature T_{S1} at which the first layer is magnetically coupled to the second layer, in place of the temperature T_{C1} in the first aspect. In addition, instead of the temperature T_{C2} , a temperature T_{S2} at which the second layer is reversed under the influence of the field H_b is used. Thereby, the second aspect can provide the same effect as in the first aspect.

In the second aspect, the coersivity of the first layer is represented by H_{C1} ; that of the second layer, H_{C2} ; a temperature at which the first layer is magnetically coupled to the second layer, T_{S1} ; a temperature at which the direction of magnetization of the second layer is reversed upon influence of the field H_b , T_{S2} ;

room temperature, T_R ; a temperature of the medium when a low-level laser beam is applied thereto, T_L ; a temperature of the medium when a high-level laser beam is applied thereto; T_H , a coupling field applied to the first layer, H_{D1} ; and a coupling field applied to the second layer, H_{D2} . In this case, the recording medium satisfies the following Formula 6, and satisfies Formulas 7 to 10 at the room temperature.

$$T_R < T_{CS1} \approx T_L < T_{CS2} \approx T_H \quad \text{Formula 6}$$

$$H_{C1} > H_{C2} + |H_{D1} \mp H_{D2}| \quad \text{Formula 7}$$

$$H_{C1} > H_{D1} \quad \text{Formula 8}$$

$$H_{C2} > H_{D2} \quad \text{Formula 9}$$

$$H_{C2} + H_{D2} < |H_{ini}| < H_{C1} \pm H_{D1} \quad \text{Formula 10}$$

In the above formulas, upper signs of double signs \pm and \mp correspond to an A (antiparallel) type medium, and lower signs correspond to a P (parallel) medium (these media will be described later).

In the first and second aspects, the recording medium is constituted by the first and second layers, each of which preferably comprises an amorphous ferrimagnetic material selected from transition metal (e.g., Fe, Co)—heavy rare earth metal (e.g., Gd, Tb, Dy, and the like) alloy compositions.

When the first and second layers are both selected from the transition metal—heavy rare earth metal alloy compositions, the direction and level of magnetization appearing outside the alloy are determined by the relationship between the direction and level of spin of transition metal atoms (to be referred to as TM hereinafter) and those of heavy rare earth metal atoms (to be referred to as RE hereinafter) inside the alloy. For example, the direction and level of TM spin are represented by a dotted vector \uparrow , those of RE spin are indicated by a solid vector \uparrow , and the direction and level of magnetization of the alloy as a whole are represented by a double-solid vector $\hat{\uparrow}$. In this case, the vector $\hat{\uparrow}$ is represented by a sum of vectors \uparrow and \uparrow . However, in the alloy, the vectors \uparrow and \uparrow are directed in the opposite directions due to the mutual effect of the TM spin and the RE spin. Therefore, when these vectors are equal to each other, the sum of vectors \downarrow and \uparrow or the sum of vectors \downarrow and \uparrow is zero (i.e., the level of magnetization appearing outside the alloy is zero). The alloy composition making the sum of vectors zero is called a compensation composition. When the alloy has another composition, it has a strength equal to a difference between the strengths of both the spins, and has a vector ($\hat{\uparrow}$ or $\hat{\downarrow}$) having a direction equal to that of larger vector. Magnetization of this vector appears outside the alloy. For example, vectors $\uparrow \downarrow$ correspond to a vector $\hat{\uparrow}$, and vectors $\downarrow \uparrow$ correspond to a vector $\hat{\downarrow}$.

When one of the strengths of the vectors of the RM spin and TM spin is larger than the other, the alloy composition is referred to as "oo rich" named after the larger spin name (e.g., RE rich).

The first and second layers can be classified into TM rich and RE rich compositions. Therefore, if the composition of the first layer is plotted along the ordinate and that of the second layer is plotted along the abscissa, the types of the recording media according to the present invention can be classified into four quadrants, as shown in FIG. 11. The P type medium described previously belongs to Quadrant I and III, and the A

type medium belongs to Quadrant II and IV. Referring to FIG. 11, the intersection (origin) of the abscissa and the ordinate represents the compensation composition of both the layers.

In view of a change in coersivity against a change in temperatures, a certain alloy composition has characteristics wherein the coersivity temporarily increases infinitely and then abruptly decreases before a temperature reaches the Cure temperature (at which the coersivity is zero). The temperature corresponding to the infinite coersivity is called a compensation temperature (Tcomp.). No compensation temperature is present between the room temperature and the Curie temperature in the TM rich alloy composition. The compensation temperature below the room temperature is nonsense in the magneto-optical recording, and hence, it is assumed in this specification that the compensation temperature is present between the room temperature and the Curie temperature.

If the first and second layers are classified in view of the presence/absence of the compensation temperature, the recording medium can be classified into four types. The recording medium in Quadrant I includes all the four types of media. The graphs of FIGS. 12A to 12D respectively show the relationship between the coersivity and the temperature of the four types of media. Note that thin curves represent characteristics of the first layer and bold curves represent those of second layer.

When the first (recording) layer and the second (reference) layer are classified in view of their RE or TM rich characteristics and in view of the presence/absence of the compensation temperature, they can be classified into 9 classes.

TABLE 1

Quadrant I			
Class	First Layer: RE rich	Second Layer: RE rich	Type
1	Tcomp.	Tcomp.	1
2	No Tcomp.	Tcomp.	2
3	Tcomp.	No Tcomp.	3
4	No Tcomp.	No Tcomp.	4
Quadrant II			
Class	First Layer: RE rich	Second Layer: TM rich	Type
5	Tcomp.	No Tcomp.	3
6	No Tcomp.	No Tcomp.	4
Quadrant III			
Class	First Layer: TM rich	Second Layer: TM rich	Type
7	No Tcomp.	No Tcomp.	4
Quadrant IV			
Class	First Layer: TM rich	Second Layer: RE rich	Type
8	No Tcomp.	Tcomp.	2
9	No Tcomp.	No Tcomp.	4

However, recording media disclosed in the prior applications have a relatively narrow range of formulas allowing an over-write operation, and a medium composition design therefore is rendered relatively difficult.

SUMMARY OF THE INVENTION

It is a first object of the present invention to provide an over write capable magneto-optical recording medium which allows relatively easy composition design.

It is a second object of the present invention to provide an over write capable recording method using the medium.

It is a third object of the present invention to provide an over write capable magneto-optical recording apparatus according to the method described above.

The present inventors made extensive studies, and found that a medium in which the direction of an initial field H_{ini} is the same as that of a bias field H_b (Classes 1, 2, and 8 in Table 1), and which satisfies predetermined formulas can allow an over-write operation if a jointing field H_{joint} is used which continuously changes from the initial field H_{ini} to the bias field H_b , thus achieving the present invention.

More specifically, according to a first aspect of the present invention, there are provided the following recording medium Nos. 1' to 3'.

Medium No. 1':

In a disk-shaped multilayered magneto-optical recording medium consisting of a perpendicular magnetic layer of at least a two-layered structure including a first layer serving as a recording layer and a second layer serving as a reference layer, the first layer comprises a transition metal-heavy rare earth alloy which is heavy rare earth rich and has a compensation temperature between a room temperature and a Curie temperature, the second layer comprises a transition metal-heavy rare earth alloy which is heavy rare earth rich and has a compensation temperature between the room temperature and the Curie temperature, and the medium satisfies the following Formula (1):

$$T_R < T_{comp.1} < T_{C1} \approx T_L \approx T_{comp.2} < T_{C2} \approx T_H \quad (1)$$

and satisfies the following Formulas at the room temperature:

$$H_{C1} - \frac{\sigma_w}{2M_{S1}t_1} > H_{C2} + \frac{\sigma_w}{H_{S2}t_2} \cong |H_b| \quad (2)$$

$$H_{C1} > \frac{\sigma_w}{2M_{S1}t_1} \quad (3)$$

$$|H_b| > -H_{C2} + \frac{\sigma_w}{2M_{S2}t_2} > 0 \quad (4)$$

$$H_{C2} + \frac{\sigma_w}{2M_{S2}t_2} < |H_{ini}| < H_{C1} - \frac{\sigma_w}{2M_{S1}t_1} \quad (5)$$

Medium No. 2':

In a disk-shaped multilayered magneto-optical recording medium consisting of a perpendicular magnetic layer of at least a two-layered structure including a first layer serving as a recording layer and a second layer serving as a reference layer, the first layer comprises a transition metal-heavy rare earth alloy which is heavy rare earth rich and does not have a compensation temperature between a room temperature and a Curie temperature, the second layer comprises a transition metal-heavy rare earth alloy which is heavy rare earth rich and has a compensation temperature between the room temperature and the Curie temperature, and the medium satisfies the following Formula (1):

$$T_R < T_{C1} \approx T_L \approx T_{comp.2} < T_{C2} \approx T_H \quad (1)$$

and satisfies the following Formulas at the room temperature:

$$H_{C1} - \frac{\sigma_w}{2M_{S1}t_1} > H_{C2} + \frac{\sigma_w}{H_{S2}t_2} \cong |H_b| \quad (2)$$

$$H_{C1} > \frac{\sigma_w}{2M_{S1}t_1} \quad (3)$$

$$|H_b| > -H_{C2} + \frac{\sigma_w}{2M_{S2}t_2} > 0 \quad (4)$$

$$H_{C2} + \frac{\sigma_w}{2M_{S2}t_2} < |H_{ini}| < H_{C1} - \frac{\sigma_w}{2M_{S1}t_1} \quad (5)$$

Medium No. 3':

In a disk-shaped multilayered magneto-optical recording medium consisting of a perpendicular magnetic layer of at least a two-layered structure including a first layer serving as a recording layer and a second layer serving as a reference layer, the first layer comprises a transition metal-heavy rare earth alloy which is transition metal rich and does not have a compensation temperature between a room temperature and a Curie temperature, the second layer comprises a transition metal-heavy rare earth alloy which is heavy rare earth rich and has a compensation temperature between the room temperature and the Curie temperature, and the medium satisfies the following Formula (1):

$$T_R < T_{C1} \approx T_L \approx T_{comp.2} < T_{C2} \approx T_H \quad (1)$$

and satisfies the following Formulas at the room temperature:

$$H_{C1} + \frac{\sigma_w}{2M_{S1}t_1} > H_{C2} + \frac{\sigma_w}{2M_{S2}t_2} \cong |H_b| \quad (2)$$

$$H_{C1} - H_{C2} > \frac{\sigma_w}{2M_{S1}t_1} - \frac{\sigma_w}{2M_{S2}t_2} \quad (2-2)$$

$$H_{C1} > \frac{\sigma_w}{2M_{S1}t_1} \quad (3)$$

$$|H_b| > -H_{C2} + \frac{\sigma_w}{2M_{S2}t_2} > 0 \quad (4)$$

$$H_{C2} + \frac{\sigma_w}{2M_{S2}t_2} < |H_{ini}| < H_{C1} + \frac{\sigma_w}{2M_{S1}t_1} \quad (5)$$

where

T_R : room temperature

$T_{comp.1}$: compensation temperature of first layer

$T_{comp.2}$: compensation temperature of second layer

T_{C1} : Curie temperature of first layer

T_{C2} : Curie temperature of second layer

T_L : temperature of recording medium when low-level laser beam is radiated

T_H : temperature of recording medium when high-level laser beam is radiated

H_{C1} : coersivity of first layer

H_{C2} : coersivity of second layer

M_{S1} : saturation magnetization of first layer

M_{S2} : saturation magnetization of second layer

t_1 : thickness of first layer

t_2 : thickness of second layer

σ_w : interface wall energy

H_{ini} : initial field

H_b : bias field

According to the present invention, there is also provided a magneto-optical recording method for recording data on a recording layer of a magneto-optical recording

medium using a bit having upward-magnetization and a bit having downward-magnetization, comprising the steps of:

- (a) providing "a disk-shaped multilayered magneto-optical recording medium consisting of a perpendicular magnetic layer of at least a two-layered structure including a first layer serving as a recording layer and a second layer serving as a reference layer" as the medium;
- (b) rotating the medium;
- (c) applying an initial field so that, before recording, only the direction of magnetization of the second layer of the medium is aligned either upward or downward;
- (d) applying, to the medium, a jointing field which changes from the initial field to a bias field having a lower intensity than the initial field;
- (e) radiating a laser beam onto the medium;
- (f) pulse modulating an intensity of the laser beam in accordance with binary data to be recorded;
- (g) applying the bias field to a portion of the medium onto which the laser beam is radiated; and
- (h) when the intensity of the pulse-modulated laser beam is at high level, forming one of the bit having upward-magnetization and that having downward-magnetization, and when the intensity of the pulse-modulated laser beam is at low level, forming the other bit.

Assuming that the direction of magnetization of only the reference layer is aligned in an "A-direction" as one of upward and downward upon application of the initial field, when the intensity of the laser beam is at high level, "A-directed" magnetization is reversed to a "non-A-direction" by means of the bias field, and a bit having "non-A-directed" (or "A-directed") magnetization is formed in the recording layer by means of the "non-A-directed" magnetization of the reference layer; and when the intensity of the laser beam is at low level, a bit having "A-directed" (or "non-A-directed") magnetization is formed in the recording layer by means of "A-directed" magnetization of the reference layer.

Furthermore, according to the present invention, there is provided an over write capable magneto-optical recording apparatus including:

- (a) means for rotating a disk-like magneto-optical recording medium;
- (b) means for applying a jointing field which continuously changes from an initial field to a bias field having a lower intensity than that of the initial field;
- (c) a laser beam light source; and
- (d) modulation means for pulse modulating an intensity of a laser beam between
 - (1) high level for, if one of upward and downward directions is given as an "A-direction" and the other direction is given as a "non-A-direction" providing a temperature suitable for forming a bit having "A-directed" magnetization, and
 - (2) low level for providing a temperature suitable for forming a bit having "non-A-directed" magnetization.

medium No. 1'

The principle of the method of the prior application invention will be described in detail using a specific medium No. 1 belonging to Class 1 (P type, Quadrant I, Type 1) shown in Table 1, and the principle of the method of the present invention will be described in detail using a specific medium No. 1'. The medium No. 1 satisfies Formula 11:

$$T_R < T_{comp.1} < T_{C1} \approx T_L \approx T_{comp.2} < T_{C2} \approx T_H$$

The graph of FIG. 13 shows this relation. Note that thin curves indicate the first layer, and bold curves indicate the second layer. Those identifications are same in the following graphs.

A condition that reverses the direction of magnetization of the second layer without reversing that of the first layer by the initial field (Hini.) at the room temperature T_R is represented by Formula 12. The medium No. 1 satisfies Formula 12 at the T_R .

$$H_{C1} > H_{C2} + (\sigma_w/2M_{S1}t_1) + (\sigma_w/2M_{S2}t_2)$$

where

H_{C1} : coersivity of first layer

H_{C2} : coersivity of second layer

M_{S1} : saturation magnetization of first layer

M_{S2} : saturation magnetization of second layer

t_1 : film thickness of first layer

t_2 : film thickness of second layer

σ_w : interface wall energy

At this time, a condition for the Hini. is represented by Formula 15. If the Hini. disappears, reversed magnetization of the second layer is influenced by magnetization of the first layer due to an exchange coupling force. The condition that can hold the direction of magnetization of the second layer is represented by Formulas 13 and 14. The medium No. 1 satisfies Formulas 13 and 14.

Formula 13: $H_{C1} > (\sigma_w/2M_{S1}t_1)$

Formula 14: $H_{C2} > (\sigma_w/2M_{S2}t_2)$

Formula 15: $H_{C2} + (\sigma_w/2M_{S2}t_2) < |H_{ini.} - | < H_{C1} - (\sigma_w/2M_{S1}t_1)$

The layer 2's magnetization of the recording medium which can satisfy Formulas 12 to 14 at the T_R is aligned along the "A direction" \uparrow ($\uparrow \downarrow$) by the Hini. which satisfies Formula 15. At this time, the recording layer 1 is maintained in the recorded state (Condition 1 in FIGS. 14 and 15).

Condition 1 is held to a point immediately before the recording. In this case, the bias field (Hb) is applied in the direction of \uparrow .

The high-temperature cycle will now be described with reference to FIG. 14.

High-Temperature Cycle

In Condition 1, when the medium temperature is increased to T_L upon irradiation of the high-level laser beam, since the temperature T_L is substantially equal to the Curie temperature T_{C1} of the first layer, magnetization of the first layer 1 disappears (Condition 2H).

When the laser-beam radiation further continues, the temperature of the medium increases accordingly. When the temperature of the medium slightly exceeds the temperature $T_{comp.2}$ of the second layer, the relationship between the strengths of the vectors is reversed ($\uparrow \downarrow \rightarrow \uparrow \downarrow$) although the directions of the RE and TM spins remain the same. For this reason, the direction of magnetization of the second layer is reversed to be along the "non-A direction" \downarrow (Condition 3H).

However, since the coersivity H_{C2} is still high at this temperature, the direction of magnetization of the second layer will not be reversed by the field Hb (\uparrow). When the temperature further increases and reaches the temperature T_H , the temperature of the second layer substantially corresponds to the Curie temperature T_{C2} ,

and magnetization of the second layer also disappears (Condition 4_H).

In Condition 4_H, when an irradiated portion is separated from the laser beam spot, the temperature of the medium begins to decrease. When the temperature of the medium decreases slightly below the temperature T_{C2}, magnetization appears in the second layer. In this case, magnetization $\hat{\uparrow}$ ($\downarrow \uparrow$) is generated by $\uparrow H_b$ (Condition 5_H). However, since the temperature is yet higher than the temperature T_{C1}, no magnetization appears in the first layer.

When the temperature of the medium further decreases below the temperature T_{comp.2}, the relationship between the strengths of the vectors is reversed ($\downarrow \uparrow \rightarrow \uparrow \downarrow$) although the directions of the RE and TM spins remain the same. As a result, the direction of magnetization of the alloy as a whole is reversed from $\hat{\uparrow}$ to the "non-A direction" $\hat{\downarrow}$ (Condition 6_H).

In Condition 6_H, since the temperature of the medium is higher than the temperature T_{C1}, magnetization of the first layer has not yet appeared. In addition, since the coersivity H_{C2} at this temperature is high, the direction of magnetization $\hat{\downarrow}$ of the second layer cannot be reversed by the field $\uparrow H_b$.

When the temperature of the medium decreases and is slightly below the temperature T_{C1}, magnetization appears in the first layer. At this time, the exchange coupling force from the second layer acts to align each of the RE and TM spins (\downarrow and \uparrow) of the first and second layers. Since the temperature of the first layer is larger than the temperature T_{comp.1}, the TM spin is larger than the RE spin, and hence, magnetization of $\downarrow \uparrow$, i.e. $\hat{\uparrow}$ appears in the first layer. This state is Condition 7_H.

When the temperature of the medium is decreased from the temperature in Condition 7_H and is below the temperature T_{comp.1}, the relationships between the strengths of the RE and TM spins of first layer is reversed ($\downarrow \uparrow \rightarrow \uparrow \downarrow$). As a result, magnetization of $\hat{\downarrow}$ appears (Condition 8_H).

Then, the temperature of the medium decreases from the temperature in Condition 8_H to the room temperature. Since the coersivity H_{C1} at the room temperature is sufficiently high, Condition 8_H is maintained without reversing the direction of magnetization of the first layer by the field $\uparrow H_b$. In this way, bit formation in the "non-A-direction" is completed.

Next, the low-temperature cycle will be described with reference to FIG. 15.

Low-Temperature Cycle

In Condition 1 immediately before recording, the medium temperature is increased to T_L upon irradiation of the low-level laser beam. Since the temperature T_L is substantially equal to the Curie temperature T_{C1} of the first layer, magnetization of the first layer disappears (Condition 2_L).

In Condition 2_L, when an irradiated portion is separated from the laser beam spot, the medium temperature begins to fall. When the medium temperature is slightly below the temperature T_{C1}, the first layer is influenced by the RE and TM spins ($\uparrow \downarrow$) of the second layer due to the exchange coupling force. In other words, the exchange coupling force acts to align each of the RE and TM spins (\uparrow and \downarrow) of the first and second layers. As a result, magnetization of $\uparrow \downarrow$, i.e., $\hat{\downarrow}$, without regard to the bias field $\uparrow H_b$, appears in the first layer (Condition 3_L). Since the temperature in Condition 3_L is

higher than the temperature T_{comp.1}, in TM spin is larger than the RE spin.

When the medium temperature is decreased below the temperature T_{comp.1}, the relationship between the RE and TM spins of the first layer is reversed ($\uparrow \downarrow \rightarrow \uparrow \downarrow$) in the same manner as in the high-temperature cycle. As a result the magnetization of the first layer is $\hat{\uparrow}$ (Condition 4_L).

Condition 4_L is maintained even if the medium temperature is decreased to the room temperature. In this way, bit formation in the "A direction" $\hat{\uparrow}$ is completed.

In this manner, a "non-A-directed" $\hat{\downarrow}$ bit is formed by the high-temperature cycle and an "A-directed" $\hat{\uparrow}$ bit is formed by the low-temperature cycle regardless of previous data. Therefore, when a laser beam is pulse modulated between high and low levels in accordance with binary data to be newly recorded, new data can be recorded. That is, an over-write operation can be achieved.

When a disk-shaped medium is used, the medium is subjected to recording in its peripheral direction while being rotated, as has been described above. For this reason, if an initial field apply means is mounted in a recording apparatus (it is convenient), newly recorded data is applied with an initial field H_{ini}. again during single rotation of the disk, and the direction of magnetization of the second layer is aligned in the "A-direction" $\hat{\uparrow}$. As a result, the data recorded in the second layer disappears, and is left in only the first layer.

More specifically, as shown in FIG. 16, when the direction of magnetization of the second layer is aligned in the "A-direction" $\hat{\uparrow}$ by the initial field H_{ini}, in the case of a P-type medium, a magnetic wall (indicated by —) is formed between the first and second layers in a portion of a bit having "non-A-directed" $\hat{\downarrow}$ magnetization, and this state is rather unstable. Therefore, if the initial field H_{ini} disappears, this state tends to be changed to an original stable state: $\frac{\hat{\downarrow}}{\hat{\uparrow}}$. For this reason, the medium No. 1 must satisfy the conditions of Formulas 13 and 14.

However, in the present invention, since a jointing field H_{joint}, jointing the initial field H_{ini} and the bias field H_b (see FIG. 17):

$$|H_b| \leq |H_{joint}| \leq |H_{ini}|$$

$$\text{for } |H_b| \neq |H_{ini}|$$

is used, the second layer is protected by the field H_{joint} until recording starts, and there is no fear of changing the state to a stable state.

Therefore, a medium which is not applicable in the prior application can be used according to the present invention. In particular, Formula 14-2 represents this fact (in the case of the medium No. 1'), and does not repeat Formula 14 in the prior application.

The medium No. 1' of the present invention will be described hereinafter in detail.

The medium No. 1' of the present invention belongs to a Class 1 recording medium (P-type, Quadrant I, Type 1) shown in Table 1.

The medium No. 1' has a relation given by Formula 11:

$$T_R < T_{comp.1} < T_{C1} \approx T_L \approx T_{comp.2} < T_{C2} \approx T_H \quad \text{Formula 11}$$

The graph of FIG. 13 shows this relation.

A condition that reverses the direction of magnetization of only the second layer without reversing that of the first layer by the initial field H_{ini} . at a temperature T_R is represented by Formula 12-2. The medium No. 1' satisfies Formula 12-2:

$$H_{C1} - \frac{\sigma_w}{2M_{S1}t_1} > H_{C2} + \frac{\sigma_w}{2M_{S2}t_2} \cong |Hb| \quad \text{Formula 12-2}$$

A condition for the field H_{ini} . is represented by Formula 15. If the field H_{ini} . disappears, reversed magnetization of the second layer is influenced by magnetization of the first layer due to an exchange coupling force. The condition that can hold the direction of magnetization of the second layer is represented by Formulas 13 to 14-2. The medium No. 1' satisfies Formulas 13 to 14-2:

$$H_{C1} > \frac{\sigma_w}{2M_{S1}t_1} \quad \text{Formual 13}$$

$$|Hb| > H_{C2} + \frac{\sigma_w}{2M_{S2}t_2} > 0 \quad \text{Formula 14-2}$$

$$H_{C2} + \frac{\sigma_w}{2M_{S2}t_2} < |H_{ini}| < H_{C1} - \frac{\sigma_w}{2M_{S1}t_1} \quad \text{Formula 15}$$

The second layer's magnetization of the recording medium which can satisfy Formulas 12 to 14-2 at the room temperature is aligned along the "A direction" \uparrow ($\uparrow \downarrow$) by the field H_{ini} . which satisfies the condition of Formula 15 to a point immediately before recording. At this time, the first layer is maintained in the recorded state (Condition 1 in FIG. 18).

Condition 1 is held to a point immediately before the recording upon protection of the field H_{joint} . In this case, the bias field (Hb) is applied in the direction of \uparrow .

High Temperature Cycle

The description with reference to the medium No. 1 of the prior application applies to this.

The description with reference to the medium No. 1 of the prior application applies to this.

In this manner a "non-A-directed" \downarrow bit is formed by the high temperature cycle, and an "A-directed" \uparrow bit is formed by the low temperature cycle regardless of the previously recorded data. Thus, when a laser beam is pulse modulated between high and low levels in accordance with binary data to be newly recorded, new data can be recorded. That is, an over-write operation can be achieved. As described above, a laser beam is divided into two proximity beams, i.e., primary and secondary beams. The primary beam is kept on at low level to perform erasure, and the secondary beam is pulse modulated between high level and base level in accordance with data, thus achieving an over-write operation (this applies to medium Nos. 2' and 3' to be described later).

However, in the present invention, since a disk-shaped medium is used, as has been described with reference to the medium No. 1, newly recorded data is applied with the initial field H_{ini} . again during single rotation of the disk, and the direction of magnetization of the second layer is aligned along the "A-direction" \uparrow . As a result, the data in the second layer disappears, and data is left in only the first layer, as shown in FIG. 19.

However, the medium used in this invention does not satisfy Formula 14. Therefore, when a medium recorded with new data is unloaded from the recording

apparatus or when the output from the jointing field apply means is reduced to zero so that the medium is free from the influence (or protection) of the magnetic field higher than Hb , magnetization of the first layer influences that of the second layer according to Formula 14-2, and the direction of magnetization of the second layer follows that of the first layer. More specifically, in the case of the P-type medium, in a portion where the first layer has a "non-A-directed" \downarrow bit, the second layer also has a "non-A-directed" \downarrow bit. Thus, the magnetic wall (indicated by $-$) between the first and second layers disappears, and a stable state: $\frac{\downarrow}{\uparrow}$ is recovered.

FIG. 20 shows a state when the influence of the field H_{joint} . disappears after recording.

As a result, since new data is kept recorded in both the first and second layers, a reproduction beam is radiated onto either layer, and data is reproduced from a beam reflected thereof. In general, a magnetic material constituting the second layer has a larger θ_k than that of the first layer. In this case, data is preferably reproduced from the second layer.

medium No. 2'

The principle of the method of the prior application invention will be described in detail using a specific medium No. 2 belonging to Class 2 (P type, Quadrant I, Type 2) shown in Table 1, and the principle of the method of the present invention will be described in detail using a specific medium No. 2'.

The medium No. 2 satisfies Formula 16:

$$T_R < T_{C1} \approx T_L \approx T_{comp.2} < T_{C2} \approx T_H$$

The graph of the FIG. 21 shows this relation.

A condition that reverses the direction of magnetization of the second layer without reversing that of the first layer by the initial field (H_{ini}) at the room temperature T_R is represented by Formula 17. The medium No. 2 satisfies Formula 17 at the T_R :

$$H_{C1} > H_{C2} + (\sigma_w/2M_{S1}t_1) + (\sigma_w/2M_{S2}t_2)$$

where

H_{C1} : coersivity of fist layer

H_{C2} : coersivity of second layer

M_{S1} : saturation magnetization of first layer

M_{S2} : saturation magnetization of second layer

t_1 : film thickness of first layer

t_2 : film thickness of second layer

σ_w : interface wall energy

At this time, a condition for the H_{ini} . is represented by Formula 20. If the H_{ini} . disappears, reversed magnetization of the second layer is influenced by magnetization of the first layer due to an exchange coupling force. The condition that can hold the direction of magnetization of the second layer is represented by Formulas 18 and 19. The medium No. 2 satisfies Formulas 18 and 19.

Formula 18: $H_{C1} > (\sigma_w/2M_{S1}t_1)$

Formula 19: $H_{C2} > (\sigma_w/2M_{S2}t_2)$

Formula 20: $H_{C2} + (\sigma_w/2M_{S2}t_2) < |H_{ini} - | < H_{C1} - (\sigma_w/2M_{S1}t_1)$

The second layer's magnetization of the recording medium which can satisfy Formulas 17 to 19 at the T_R is aligned along the "A direction" \uparrow ($\uparrow \downarrow$) by the H_{ini} . which satisfies Formula 20. At this time the first layer is

maintained in the recorded state (Condition 1 in FIGS. 22 and 23).

Condition 1 is held to a point immediately before the recording. In this case, the bias field (Hb) is applied in the direction of \uparrow .

The high-temperature cycle will now be described with reference to FIG. 22.

High-Temperature Cycle

In Condition 1, when the medium temperature is increased to T_L upon irradiation of the high-level laser beam, since the temperature T_L is substantially equal to the Curie temperature T_{C1} of the first layer magnetization of the first layer disappears (Condition 2_H).

When the laser-beam radiation further continues, the temperature of the medium increases accordingly. When the temperature of the medium slightly exceeds the temperature $T_{comp.2}$ of the second layer, the relationship between the strengths of the vectors is reversed ($\uparrow \downarrow \rightarrow \downarrow \uparrow$) although the directions of the RE and TM spins remain the same. For this reason, the direction of magnetization of the second layer is reversed to the "non-A-direction" \Downarrow (Condition 3_H).

However, since the coersivity H_{C2} is still high at this temperature, the direction of magnetization of the second layer will not be reversed by the field Hb(\uparrow). When the temperature further increases and reaches the temperature T_H , the temperature of the second layer substantially corresponds to the Curie temperature T_{C2} , and magnetization of the second layer also disappears (Condition 4_H).

In Condition 4_H, when an irradiated portion is separated from the laser beam spot, the temperature of the medium begins to decrease. When the temperature of the medium decreases slightly below the temperature T_{C2} , magnetization appears in the second layer. In this case, magnetization \Updownarrow ($\downarrow \uparrow$) is generated by \uparrow Hb (Condition 5_H). However, since the temperature is yet higher than the temperature T_{C1} , no magnetization appears in the first layer.

When the temperature of the medium further decreases below the temperature $T_{comp. 2}$, the relationship between the strengths of the vectors is reversed ($\downarrow \uparrow \rightarrow \uparrow \downarrow$) although the directions of the RE and TM spins remain the same. As a result, the direction of magnetization of the alloy as a hole is reversed \Updownarrow to the "non-A direction" \Downarrow (Condition 6_H).

In Condition 6_H, since the temperature of the medium is higher than the temperature T_{C1} , magnetization of the first layer has not yet appeared. In addition, since the coersivity H_{C2} at this temperature is high, the direction of magnetization \Downarrow of the second layer cannot be reversed by the field \uparrow Hb.

When the temperature of the medium decreases and is slightly below the temperature T_{C1} , magnetization appears in the first layer. At this time, the exchange coupling force from the second layer acts to align each of the RE and TM spins (\downarrow and \uparrow) of the first and second layers. Thus, magnetization of $\downarrow \uparrow$, i.e. \Downarrow appears in the first layer. This state is Condition 7_H.

Then, the temperature of the medium decreases from the temperature in Condition 7_H to the room temperature. Since the coersivity H_{C1} at the room temperature is sufficiently high, Condition 7_H is maintained without reversing the direction of magnetization of the first layer by the field \uparrow Hb. In this way, bit formation in the "non-A direction" is completed.

Next, the low-temperature cycle will be described with reference to FIG. 23.

Low-Temperature Cycle

In Condition 1 immediately before recording, the medium temperature is increased to T_L upon irradiation of the low-level laser beam. Since the temperature T_L is substantially equal to the Curie temperature T_{C1} of the first layer, magnetization of the first layer disappears (Condition 2_L).

In Condition 2_L, when an irradiated portion is separated from the laser beam spot, the medium temperature begins to fall. When the medium temperature is slightly below the temperature T_{C1} , the first layer is influenced by the RE and TM spins ($\uparrow \downarrow$) of the second layer due to the exchange coupling force. In other words, the exchange coupling force acts to align each of the RE and TM spins (\uparrow and \downarrow) of the first and second layers. As a result, magnetization of $\uparrow \downarrow$, e.g., \Updownarrow , appears in the first layer (Condition 3_L).

Condition 3_L is maintained even if the medium temperature is decreased to the room temperature. As a result, a bit in the "A direction" is formed in the first layer.

In this manner, a "non-A-directed" \Downarrow bit is formed by the high temperature cycle, and an "A-directed" \Updownarrow bit is formed by the low temperature cycle regardless of the previously recorded data. Thus, when a laser beam is pulse modulated between high and low levels in accordance with binary data to be newly recorded, new data can be recorded. That is, an over-write operation can be achieved.

When a disk-shaped medium is used, as has been described with reference to the medium No. 1, the direction of magnetization of the second layer is aligned along the "A-direction" \Updownarrow during single rotation of the disk. As a result, the data in the second layer is erased, and the data is left in only the first layer. Therefore, when the field Hini. disappears, an original stable state may be undesirably set. In order to prevent this, the medium No. 1 must satisfy conditions of Formulas 18 and 19.

However, in the present invention, since the jointing field Hjoint. (see FIG. 17) jointing Hini. an Hb is used, the second layer is protected by the field Hjoint. to a point immediately before the recording, and there is no fear of changing the state to a stable state.

Therefore, a medium which is not applicable in the prior application can be used according to the present invention. In particular Formula 19-2 (in the case of the medium No. 2') represents this, and does not repeat Formula 19 in the prior application.

The medium No. 2' of the present invention will be described hereinafter in detail.

The medium No. 2' of the present invention belongs to a Class 2 recording medium (P-type, Quadrant I, Type 2) shown in Table 1. The medium No. 2' has a relation given by Formula 16:

$$T_R < T_{C1} \approx T_L \approx T_{comp.2} < T_{C2} \approx T_H \quad \text{Formula 16}$$

The graph of FIG. 21 shows this relation. A condition that reverses the direction of magnetization of only the second layer without reversing that of the first layer by the initial field Hini. at a temperature T_R is represented by Formula 17-2. The medium No. 2' satisfies Formula 17-2:

$$H_{C1} - \frac{\sigma_w}{2M_{S1}t_1} > H_{C2} + \frac{\sigma_w}{2M_{S2}t_2} \cong |Hb| \quad \text{Formula 17-2}$$

A condition for the field Hini. is represented by Formula 20. If the field Hini. disappears, reversed magnetization of the second layer is influenced by magnetization of the first layer due to an exchange coupling force. The condition that can hold the direction of magnetization of the second layer is represented by Formulas 18 to 19-2. The medium No. 2' satisfies Formulas 18 to 19-2:

$$H_{C1} > \frac{\sigma_w}{2M_{S1}t_1} \quad \text{Formual 18}$$

$$|Hb| > -H_{C2} + \frac{\sigma_w}{2M_{S2}t_2} > 0 \quad \text{Formula 19-2}$$

$$H_{C2} + \frac{\sigma_w}{2M_{S2}t_2} < |Hini.| < H_{C1} - \frac{\sigma_w}{2M_{S1}t_1} \quad \text{Formula 20}$$

The second layer's magnetization of the recording medium which can satisfy Formulas 17 to 19-2 at the room temperature is aligned along the "A direction" (↑ ↓) by the field Hini. which satisfies the condition of Formula 15 to a point immediately before recording. At this time, the first layer is maintained in the recorded state (in the same manner as in FIG. 18).

Condition 1 is held to a point immediately before the recording upon protection of the field Hjoint. In this case, the bias field (Hb) is applied in the direction of ↑.

High Temperature Cycle

The description with reference to the medium No. 2 of the prior application applies to this.

Low Temperature Cycle

The description with reference to the medium No. 2 of the prior application applies to this.

In this manner, a "non-A-directed" bit is formed by the high temperature cycle, and an "A-directed" bit is formed by the low temperature cycle regardless of the previously recorded data. Thus, when a laser beam is pulse modulated between high and low levels in accordance with binary data to be newly recorded, new data can be recorded. That is, an over-write operation can be achieved.

However, in the present invention, since a disk-shaped medium is used, as has been described with reference to the medium No. 2, newly recorded data is applied with the initial field Hini. again during single rotation of the disk, and the direction of magnetization of the second layer is aligned along the "A-direction" (↑ ↓). As a result, the data in the second layer disappears, and data is left in only the first layer in the same manner as in FIG. 19.

However, the medium used in this invention does not satisfy Formula 19. Therefore, when a medium recorded with new data is unloaded from the recording apparatus or when the output from the Hjoint apply means is reduced to zero so that the medium is free from the influence (or protection) of the magnetic field higher than Hb, magnetization of the first layer influences that of the second layer according to Formula 19-2, and the direction of magnetization of the second layer follows that of the first layer. More specifically, in the case of the P-type medium, in a portion where the first layer has a "non-A-directed" bit, the second

layer also has a "non-A-directed" bit. Thus, the magnetic wall (indicated by -) between the first and second layers disappears, and a stable state: $\frac{\uparrow}{\downarrow}$ is set.

When the of the field Hjoint. disappears after recording, the same state as in FIG. 20 is established.

As a result, since new data is kept recorded in both the first and second layers, a reproduction beam is radiated onto either layer, and data is reproduced from a beam reflected thereby. In general, a magnetic material constituting the second layer has a larger θ_k than that of the first layer. In this case, data is preferably reproduced from the second layer.

medium No. 3'

The principle of the method of the prior application invention will be described in detail using a specific medium No. 8 belonging to Class 8 (A type, Quadrant IV, Type 2) shown in Table 1, and the principle of the method of the present invention will be described in detail using a specific medium No. 3'.

The medium No. 8 satisfies Formula 21:

$$T_R < T_{C1} \approx T_L \approx T_{comp.2} < T_{C2} \approx T_H$$

The graph of FIG. 24 shows this relation.

A condition that reverses the direction of magnetization of the second layer without reversing that of the first layer by the initial field (Hini.) at the room temperature T_R is represented by Formula 22. The medium No. 8 satisfies Formula 22 at the T_R :

$$H_{C1} > H_{C2} + |(\sigma_w/2M_{S1}t_1) - (\sigma_w/2M_{S2}t_2)|$$

- where H_{C1} : coersivity of first layer
- H_{C2} : coersivity of second layer
- M_{S1} : saturation magnetization of first layer
- M_{S2} : saturation magnetization of second layer
- t_1 : film thickness of first layer
- t_2 : film thickness of second layer
- σ_w : interface wall energy

At this time, a condition for the Hini. is represented by Formula 25. If the Hini. disappears, reversed magnetization of the second layer is influenced by magnetization of the first layer due to an exchange coupling force. The condition that can hold the direction of magnetization of the second layer is represented by Formulas 23 and 24. The medium No. 8 satisfies Formulas 23 and 24.

Formula 23: $H_{C1} > (\sigma_w/2M_{S1}t_1)$

Formula 24: $H_{C2} > (\sigma_w/2M_{S2}t_2)$

Formula 25:
 $H_{C2} + (\sigma_w/2M_{S2}t_2) < |Hini.| < H_{C1} + (\sigma_w/2M_{S1}t_1)$

The second layer's magnetization of the recording medium which can satisfy Formulas 22 to 24 at the T_R is aligned along the "A direction" (↑ ↓) by the Hini. which satisfies Formula 25. At this time the first layer is maintained in the recorded state (Condition 1 in FIGS. 25 and 26).

Condition 1 is held to a point immediately before the recording. In this case, the bias field (Hb) is applied in the direction of ↑.

The high-temperature cycle will now be described with reference to FIG. 25.

High-Temperature Cycle

In Condition 1, when the medium temperature is increased to T_L upon irradiation of the high-level laser beam, since the temperature T_L is substantially equal to the Curie temperature T_{C1} of the first layer, magnetization of the first layer disappears (Condition 2_H).

When the laser-beam radiation continues and the medium temperature is slightly higher than the temperature $T_{comp.2}$, the relationship between the strengths of the RE and TM spins is reversed ($\uparrow\downarrow \rightarrow \downarrow\uparrow$) although the directions thereof (\uparrow and \downarrow) remain the same. As a result, the direction of the magnetization of the second layer is reversed to "non-A direction" \Downarrow . This state is Condition 3_H .

At this temperature, however, since the coersivity H_{C2} is yet high, magnetization \Downarrow of the second layer will not be reversed by the bias field $\uparrow H_b$. Assume that the laser-beam radiation further continues and the medium temperature is increased to T_H . Since the temperature T_H is substantially equal to the temperature T_{C2} , magnetization of the second layer also disappears (Condition 4_H).

In Condition 4_H , when an irradiated portion is separated from the laser beam spot, the temperature of the medium begins to decrease. When the temperature of the medium decreases slightly below the temperature T_{C2} , magnetization of the second layer appears. In this case, magnetization \Downarrow ($\downarrow\uparrow$) is generated by $\uparrow H_b$. However, since the temperature is yet higher than the temperature T_{C1} , no magnetization appears in the first layer. This state is Condition 5_H .

When the temperature of the medium is further decreased slightly below the temperature $T_{comp.1}$, the relationship between the strengths of the RE and TM spins is reversed ($\downarrow\uparrow \rightarrow \uparrow\downarrow$) without reversing the directions thereof (\downarrow and \uparrow). As a result the direction of magnetization of the second layer is reversed to "non-A direction" \Downarrow . In this state, since the coersivity H_{C2} is already sufficiently high, magnetization \Downarrow of the second layer will not be reversed by the bias field $\uparrow H_b$. In this case, since the medium temperature is yet higher than the temperature T_{C1} , no magnetization appears in the first layer. This state is Condition 6_H .

When the medium temperature further decreases slightly below the temperature T_{C1} , magnetization also appears in the first layer. At this time, magnetization ($\downarrow\uparrow$) of the first layer 1 influences the first layer due to the exchange coupling force to align each of the RE and TM spins (\downarrow and \uparrow) of the first and second layers. For this reason magnetization $\downarrow\uparrow$, i.e., $\hat{\uparrow}$ appears in the first layer (Condition 7_H).

Then, the temperature of the medium decreases from the temperature in Condition 7_H to the room temperature. Since the coersivity H_{C1} at the room temperature is sufficiently high, magnetization of the first layer is stably maintained. In this way, bit formation in the "A direction" $\hat{\uparrow}$ is completed.

Next, the low-temperature cycle will be described with reference to FIG. 26.

Low-Temperature Cycle

In Condition 1 immediately before recording, the medium temperature is increased to T_L upon irradiation of the low-level laser beam. Since the temperature T_L is substantially equal to the Curie temperature T_{C1} of the first layer, magnetization of the first layer disappears. In this state, however, since the coersivity H_{C2} of the sec-

ond layer is sufficiently high, magnetization of the second layer will not be reversed by the bias field $\uparrow H_b$ (Condition 2_L).

In Condition 2_L , when an irradiated portion is separated from the laser beam spot, the medium temperature begins to fall. When the medium temperature is slightly below the temperature T_{C1} , the respective spins of the first layer are influenced by the RE and TM spins ($\uparrow\downarrow$) of the second layer due to the exchange coupling force. In other words, the exchange coupling force acts to align each of the RE and TM spins (\uparrow and \downarrow) of the first and second layers. As a result, magnetization of $\uparrow\downarrow$, i.e., \Downarrow , without regard to the bias field $\uparrow H_b$, appears in the first layer 1. This state is Condition 3_L .

Condition 3_L is maintained even if the medium temperature is decreased to the room temperature. In this way, bit formation in the "non-A direction" \Downarrow is completed.

In this manner, an "A-directed" $\hat{\uparrow}$ bit is formed in the first layer by the high temperature cycle, and a "non-A-directed" \Downarrow bit is formed in the first layer by the low temperature cycle regardless of the previously recorded data. Thus, when a laser beam is pulse modulated between high and low levels in accordance with binary data to be newly recorded, new data can be recorded. That is, an over-write operation can be achieved.

When a disk-shaped medium is used, as has been described with reference to the medium No. 1, the direction of magnetization of the second layer is aligned along the "A-direction" $\hat{\uparrow}$ during single rotation of the disk. As a result, the data in the second layer is erased, and the data is left in only the first layer. Therefore, when the field H_{ini} disappears, an original stable state may be undesirably set. In order to prevent this, the medium No. 8 must satisfy conditions of Formulas 23 and 44.

However, in the present invention, since the jointing field H_{joint} (see FIG. 17) jointing H_{ini} and H_b is used, the second layer is protected by the field H_{joint} to a point immediately before the recording, and there is no fear of changing the state to a stable state.

Therefore, a medium which is not applicable in the prior application can be used according to the present invention. In particular, Formula 24-2 (in the case of the medium No. 3') represents this, and does not repeat Formula 24 in the prior application.

The medium No. 3' of the present invention will be described hereinafter in detail.

The medium No. 3' of the present invention belongs to a Class 8 recording medium (A-type, Quadrant IV, Type 2) shown in Table 1.

The medium No. 3' has a relation given by Formula 21:

$$T_r < T_{C1} \approx T_L \approx T_{comp.2} < T_{C2} \approx T_H \quad \text{Formula 21}$$

The graph of FIG. 24 shows this relation.

A condition that reverses the direction of magnetization of only the second layer without reversing that of the first layer by the initial field H_{ini} at a temperature T_R is represented by Formulas 22-2 and 22-3. The medium No. 3' satisfies Formulas 22-2 and 22-3:

$$H_{C1} + \frac{\sigma_w}{2M_{S1}^2} > H_{C2} + \frac{\sigma_w}{2M_{S2}^2} \cong |H_b| \quad \text{Formula 22-2}$$

-continued

$$H_{C1} - H_{C2} > \frac{\sigma_w}{2M_{S1t1}} - \frac{\sigma_w}{2M_{S2t2}} \quad \text{Formula 22-3}$$

A condition for the field H_{ini} is represented by Formula 25. If the field H_{ini} disappears, reversed magnetization of the second layer is influenced by magnetization of the first layer due to an exchange coupling force. The condition that can hold the direction of magnetization of the second layer is represented by Formulas 23 to 24-2. The medium No. 3' satisfies Formulas 23 to 24-2:

$$H_{C1} > \frac{\sigma_w}{2M_{S1t1}} \quad \text{Formual 23}$$

$$|H_b| > -H_{C2} + \frac{\sigma_w}{2M_{S2t2}} > 0 \quad \text{Formula 24-2}$$

$$H_{C2} + \frac{\sigma_w}{2M_{S2t2}} < |H_{ini}| < H_{C1} + \frac{\sigma_w}{2M_{S1t1}} \quad \text{Formula 25}$$

The second layer's magnetization of the recording medium which can satisfy Formulas 22 to 24-2 at the room temperature is aligned along the "A direction" \uparrow (\uparrow \downarrow) by the field H_{ini} which satisfies the condition of Formula 25 to a point immediately before recording. At this time, the first layer is maintained in the recorded state (in the same manner as in FIG. 18).

Condition 1 is held to a point immediately before the recording upon protection of the field H_{joint} . In this case, the bias field (H_b) is applied in the direction of \uparrow .

High Temperature Cycle

The description with reference to the medium No. 8 of the prior application applies to this.

Low Temperature Cycle

The description with reference to the medium No. 8 of the prior application applies to this.

In this manner, an "A-directed" \uparrow bit is formed in the first layer by the high temperature cycle, and a "non-A-directed" \downarrow bit is formed by the low temperature cycle regardless of the previously recorded data. Thus, when a laser beam is pulse modulated between high and low levels in accordance with binary data to be newly recorded, new data can be recorded. That is, an over-write operation can be achieved.

However, in the present invention, since a disk-shaped medium is used, as has been described with reference to the medium No. 8, newly recorded data is applied with the initial field H_{ini} again during single rotation of the disk, and the direction of magnetization of the second layer is aligned along the "A-direction" \uparrow . As a result, the data in the second layer disappears, and data is left in only the first layer, as shown in FIG. 27.

However, the medium used in this invention does not satisfy Formula 49. Therefore, when a medium recorded with new data is unloaded from the recording apparatus or when the output from the jointing field apply means is reduced to zero so that the medium is free from the influence (or protection) of the magnetic field higher than H_b , magnetization of the first layer influences that of the second layer according to Formula 19-2, and the direction of magnetization of the second layer follows that of the first layer. More specifically, in the case of the P-type medium, in a portion where the first layer has an "A-directed" \uparrow bit, the

second layer also has a "non-A-directed" \downarrow bit. Thus, the magnetic wall (indicated by $-$) between the first and second layers disappears, and a stable state: $\frac{\sigma}{\sigma}$ is set. When the influence of the field H_{joint} disappears after recording, a state shown in FIG. 28 is established. As a result, since new data is kept recorded in both the first and second layers, a reproduction beam is radiated onto either layer, and data is reproduced from a beam reflected thereby. In general, a magnetic material constituting the second layer has a larger θ_k than that of the first layer. In this case, data is preferably reproduced from the second layer.

Note that the medium Nos. 1' to 3'' accidentally encounter an external field H_{or} such as a leakage field, a condition that can hold data in the second If the field H_{joint} is positive:

$$-H_{C2} - \frac{\sigma_w}{2M_{S2t2}} < H_{or} < -H_{C2} + \frac{\sigma_w}{2M_{S2t2}}$$

If the field H_{joint} is negative:

$$H_{C2} - \frac{\sigma_w}{2M_{S2t2}} < H_{or} < H_{C2} + \frac{\sigma_w}{2M_{S2t2}}$$

An attention must be paid to the external field H_{or} .

BRIEF DESCRIPTION OF THE DRAWINGS

FIG. 1 is an illustration for explaining a recording principle of a magneto-optical recording

FIG. 2 is an illustration for explaining a reading principle of the magneto-optical recording

FIGS. 3 and 4 are charts showing an output waveform of laser beams;

FIG. 5A is a diagram of a multilayered structure of a recording medium;

FIG. 5B is a diagram showing the direction of magnetization of first and second layers;

FIG. 6 is a graph showing the relationship between coersivity, and temperature;

FIG. 7 illustrate changes in the direction of magnetization at high level;

FIG. 8 illustrates changes in the direction of magnetization at, low level;

FIG. 9 illustrates flows of the changes in the direction of magnetization shown in FIGS. 7 and 8 for respective P- and A-type media;

FIG. 10 illustrates diagrams showing the direction of magnetization of first and second layers for respective P- and A-type media;

FIG. 11 is a map wherein the types of media of the present invention as classified into four quadrants;

FIGS. 12A to 12D are graphs showing the relationship between the coersivity and the temperature respectively for media of Type I to IV;

FIGS. 13 is a graph showing the relationship between the coersivity and the temperature for a medium No. 1;

FIGS. 14 and 15 are diagrams showing changes in the direction of magnetization in high- and low-temperature cycles of a medium No. 1;

FIGS. 16, 19 and 20 illustrate diagrams showing the direction of magnetization of first and second layers;

FIG. 17 is a graph showing the relationship between field intensity and rotation angle of disk;

FIG. 18 illustrates diagram showing the direction of magnetization of first and second layers;

FIG. 21 is a graph showing the relationship between the coersivity and the temperature for the medium No. 2;

FIGS. 22 and 23 are diagrams showing the changes in the direction of magnetization in high- and low-temperature cycles of a medium No. 2;

FIG. 24 is a graph showing the relationship between the coersivity and the temperature for a medium No. 8;

FIGS. 25 and 26 are diagrams showing the changes in the direction of magnetization in high-and low-temperature cycles of the medium No. 8;

FIGS. 27 and 28 illustrate diagrams showing the direction of magnetization of first and second layers;

FIG. 29 is a perspective view of a magneto-optical recording apparatus showing an embodiment of the present invention;

FIG. 30 is a graph showing field intensity relative to position on a permanent magnet; and

FIG. 31 is a perspective view of a magneto-optical recording apparatus showing an embodiment of the present invention.

DETAILED DESCRIPTION OF THE PREFERRED EMBODIMENTS

The present invention will now be described by way of examples. However, the present invention is not limited to the following examples.

(Example 1 One of Media No. 1')

A disk-shaped glass substrate was prepared which has a thickness of 1.2 mm and a diameter of 200 mm and in which a large number of grooves each having a depth of 1,100 Å and a pitch of 1.6 μm were formed.

A vacuum vapor deposition apparatus was used in this example. It included two crucibles as evaporation sources shown in Table 2 and two units for heating the respective sources with an electron beam.

The glass substrate was placed inside a chamber of the apparatus. The chamber of the apparatus was temporarily evacuated to a vacuum of 1×10^{-6} Torr. or less. Thereafter, deposition was performed at a deposition rate of about 3 Å/sec while maintaining the chamber at a vacuum of 1 to 2×10^{-6} Torr. Then, a 500-Å first layer (recording layer) of Gd₁₄Dy₁₂Fe₇₄ (note: appendixes, atom, %) was formed on the substrate. Subsequently, the evaporation sources were exchanged while maintaining the vacuum state. Then, deposition was performed again to form a 505-Å thick second layer (reference layer) of

The first and second layers were perpendicular magnetic layers.

In this way, a double-layered recording medium No. 1' belonging to Class 1 (i.e., P-type, Quadrant I, and Type 1) was manufactured.

Table 2 below shows the manufacturing conditions and characteristics of the medium No. 1'.

TABLE 2

	first layer	second layer
Evaporation Source (2 Elements)	GdDy alloy	GdTb alloy
Film Thickness (Å)	500	505
Ms (emu/cc)	100	110
Hc (oe)	5600	1200
Tc (°C.)	150	210
Tcomp. (°C.)	110	180
σ_w		1.5 erg/cm ²

TABLE 2-continued

	first layer	second layer
(Room Temperature)		

If $T_L = 160^\circ \text{C}$., $T_H = 220^\circ \text{C}$., $H_{ini} = 3,000 \text{ Oe}$ and $H_b = 300 \text{ Oe}$, this medium satisfies Formula 11:

$$T_R < T_{comp.1} < T_{C1} \approx T_{C1} \approx T_L \approx T_{comp.2} < T_{C2} \approx T_H$$

and Formula 12-2:

$$H_{C1} - (\sigma_w/2M_{S1t1}) = 4,000 \text{ Oe} > H_{C2} + (\sigma_w/2M_{S2t2}) = 2,550 \text{ Oe} \geq |H_b| = 300 \text{ Oe}$$

In Formula 15, since

$$H_{C1} - (\sigma_w/M_{S1t1}) = 4,100 \text{ Oe} > 0$$

$$H_{C2} + (\sigma_w/2M_{S2t2}) = 2,550 \text{ Oe}$$

if an initial field (H_{ini}) is 3,000 Oe, the medium No. 1 can satisfy Formula 15. Thus, the direction of magnetization of the second layer is reversed at the room temperature due to the initial field (H_{ini}) without reversing that of the first layer.

In addition, since the medium No. 1' satisfies: Formula 13:

$$H_{C1} = 5,600 \text{ Oe} > (\sigma_w/2M_{S1t1}) = 1,500 \text{ Oe}$$

and Formula 14-2:

$$|H_b| = 300 \text{ Oe} > -H_{C2} + (\sigma_w/2M_{S2T2}) = 150 \text{ Oe} > 0$$

if the initial field (H_{ini}) is removed, magnetization of the first and second layers can be maintained under applying the jointing field H_{joint} . Therefore, when the initial field (H_{ini}) = 3,000 Oe is applied in the "A direction" (↑), the bias field $H_b = 300 \text{ Oe}$ is applied in the "A direction" (↑) and the jointing field H_{joint} is used for connecting then, over-write operation is enabled. (Example 2 . . . One of Media No. 2') A 500-Å thick first layer (recording layer) of Tb₂₇Fe₇₃ and a 303-Å thick second layer (reference layer) of Dy₂₇Fe₅₅Co₁₈ were sequentially formed on a substrate in the same manner as in Example 1. Then, a medium No. 2' belonging to Class 2 (i.e., P type, Quadrant I, an Type 2) was manufactured.

Table 3 below shows the manufacturing conditions and characteristics of the medium No. 2'.

TABLE 3

	first layer	second layer
Evaporation source (2 Elements)	Tb	Dy
Film Thickness t (Å)	500	303
Ms (emu/cc)	120	150
Hc (Oe)	7000	1500
Tc (°C.)	135	210
Tcomp. (°C.)	None	180
σ_w		1.5 erg/cm ²
(Room Temperature)		

If $T_L = 150^\circ \text{C}$., $T_H = 220^\circ \text{C}$., $H_{ini} = 3,500 \text{ Oe}$ and $H_b = 300 \text{ Oe}$, this medium satisfies:

Formula 16:

$$T_R < T_{C1} \approx T_L \approx T_{comp.2} < T_{C2} \approx T_H$$

and Formula 17-2:

$$H_{C1} - (\sigma_w/2M_{S1t1}) = 5,750 \text{ Oe} > H_{C2} + (\sigma_w/2M_{S2t2}) = 3,150 \text{ Oe} \cong |Hb| = 300 \text{ Oe}$$

In Formula 20, since $H_{C1} - (\sigma_w/2M_{S1t1}) = 5,750 \text{ Oe}$

$$H_{C2} + (\sigma_w/2M_{S2t2}) = 3,150 \text{ Oe}$$

if an initial field (Hini.) is 3,500 Oe, the medium No. 2' can satisfy Formula 20. Thus, the direction of magnetization of the second layer is reversed at the room temperature due to the initial field (Hini.) without reversing that of the first layer.

In addition, since the medium No. 2' satisfies: Formula 18:

$$H_{C1} = 7,000 \text{ Oe} > (\sigma_w/2M_{S1t1}) = 1,250 \text{ Oe}$$

and Formula 19-2:

$$|Hb| = 300 > -H_{C2} + (\sigma_w/2M_{S2t2}) = 150 \text{ Oe} > 0$$

if the initial field (Hini.) is removed, magnetization of the first and second layers can be maintained under applying the jointing field Hjoint.

Therefore, when the initial field (Hini.) = 3,500 Oe is applied in the "A direction" (↑), the bias field Hb = 300 Oe is applied in the "A direction" (↑) and the jointing field Hjoint is used for connecting them, an over-write operation is enabled. (Example 3 . . . One of Media No. 3')

A 2-element RF magnetron sputtering apparatus was used and included two targets DyFeCo alloy and GdDyFeCo alloy shown in Table 4. Targets DyFeCo alloy were first used, and GdDyFeCo alloy were then used. A 1.2-mm thick, 200-mm diameter glass substrate was placed inside a chamber of the apparatus.

The chamber of the apparatus was temporarily evacuated to a vacuum of 7×10^{-7} Torr. or less, and 5×10^{-3} Torr. of Ar gas was introduced therein. Then, sputtering was performed at a deposition rate of about 2 Å/sec. Thereby, a 500-Å thick first layer (recording layer) of Dy₂₃Fe₆₉Co₈ was formed on the substrate. Subsequently, the targets were replaced while maintaining the vacuum state. Thereafter, sputtering was performed again to form a 435-Å thick second layer of Gd₂₂Dy₃Fe₆₉Co₄ on the first layer. Note that the first and second layers were perpendicular magnetic films.

In this way, a medium No. 3' belonging to Class 8 (i.e., A type, Quadrant IV, and Type 2) was manufactured.

Table 4 shows the manufacturing conditions and characteristics of the medium No. 3'.

TABLE 4

Target	first layer	second layer
	DyFeCo alloy	GdDyFeCo alloy
Film Thickness t (Å)	500	435
Ms (emu/cc)	100	200
Hc (Oe)	6500	1000
Tc (°C.)	140	220
Tcomp. (°C.)	None	190
σ_w (Room Temperature)	2.0 erg/cm ²	

If $T_L = 150^\circ \text{C.}$, $T_H = 230^\circ \text{C.}$, Hini = 3,000 Oe and Hb = 300 Oe, this medium satisfies:

Formula 21:

$$T_R < T_{C1} \approx T_L \approx T_L \approx T_{\text{comp.2}} < T_{C2} \approx T_H$$

Formula 22-2:

$$H_{C1} + (\sigma_w/2M_{S1t1}) = 8,500 \text{ Oe} > H_{C2} - (\sigma_w/2M_{S2t2}) = 2,150 \text{ Oe} \cong |Hb| = 300 \text{ Oe}$$

and Formula 22-3:

$$H_{C1} - H_{C2} = 5,500 \text{ Oe} > (\sigma_w/2M_{S1t1}) - (\sigma_w/2M_{S2t2}) = 850 \text{ Oe}$$

In Formula 25, since $H_{C1} + (\sigma_w/2M_{S1t1}) = 2,150 \text{ Oe}$

$$H_{C2} + (\sigma_w/2M_{S2t2}) = 8,500 \text{ Oe}$$

if an initial field (Hini.) is 2,500 Oe, the medium No. 3' can satisfy Formula 25. Thus, the direction of magnetization of the second layer is reversed at the room temperature due to the initial field (Hini.) without reversing that of the first layer.

In addition, since the medium No. 6 satisfies:

Formula 23:

$$H_{C1} = 6,500 \text{ Oe} > (\sigma_w/2M_{S1t1}) = 2,000 \text{ Oe}$$

and Formula 24-2:

$$|Hb| = 300 \text{ Oe} > -H_{C2} + (\sigma_w/2M_{S2t2}) = 150 \text{ Oe} > 0$$

If the initial field (Hini.) is removed, magnetization of the first and second layers can be maintained under applying the jointing field Hjoint.

Therefore, when the initial field (Hini.) = 2,500 Oe is applied in the "A direction" (↑), the bias field Hb = 300 Oe is applied in the "non-A direction" (↓) and the jointing field Hjoint is used for connecting them, an over-write operation is enabled.

An embodiment of an apparatus for magneto-optically recording and reproducing data using the recording medium described above will be described hereinafter. FIG. 29 shows the overall arrangement of the apparatus.

The apparatus basically comprises:

a rotating means 21 for rotating a recording medium 20;

a means for applying the jointing field Hjoint. which continuously changes from the initial field Hini. to the bias field Hb;

a laser beam light source 23; and

a means 24 for pulse modulating the intensity of a laser beam in accordance with binary data to be recorded between (1) high level for providing a medium temperature T_L suitable for forming one of a bit having upward-magnetization and a bit having downward-magnetization and (2) low level for providing the medium temperature T_L suitable for forming the other bit. A light source 30 for supplying a leading beam described with reference to FIG. 4 may be provided as indicated by an imaginary line.

In this embodiment, the jointing field apply means comprises an initial field apply means 22, a bias field apply means, and an iron segment 26 for coupling these means 22 and 25. The iron segment 26 encloses and adds

the leakage fields from the means 22 and 25 so as to generate a magnetic field which continuously changes from one to another.

As the initial field apply means 22, a permanent magnet having $H_{ini.} = 3,000$ Oe (or 3,500 Oe) and "A-directed" \uparrow magnetization is used. In place of the permanent magnet, an electromagnet may be used. As the bias field apply means 25, a permanent magnet having $H_b = 300$ Oe and "A-directed" \uparrow magnetization is used. An electromagnet may be used in place of the permanent magnet. When an application of reproduction field H_R is to be applied, an electromagnet having a variable field intensity is preferably used.

Note that the joint field apply means is stationarily arranged in the recording apparatus, and is not moved together with a recording head (pickup) including the light source 23. With this arrangement, the pickup can be made lightweight, and high-speed access can be achieved.

The joint field apply means need not always comprise two magnets 22 and 25 for applying the fields $H_{ini.}$ and H_b , respectively. For example, in a single permanent magnet 27, its field intensity distribution has a maximum value somewhere (at substantially the central portion), and the intensity is gradually decreased toward the periphery, as shown in FIG. 30. Therefore, if a magnetic field at a high-intensity portion of a single magnet is used as the $H_{ini.}$, and that at a low-intensity portion is used as the H_b , thus allowing generation of the jointing field.

In this case, the magnet is arranged, as shown in FIG. 31 to apply the "A-directed" \uparrow $H_{ini.} = 2,500$ Oe and $H_b = 300$ Oe to predetermined positions of the medium. Thus, the magnet can be used as a recording apparatus.

A magneto-optical recording operation using the recording apparatus shown in FIG. 29 will be described below. The recording medium (No. 1') of the embodiment 1 is moved at a constant linear speed of 8.5 m/sec by the rotating means 21. A laser beam is radiated on the rotating medium. The beam is adjusted by a modulator 24 to obtain outputs of 8.9 mW (on disk) at high level and 6.1 mW (on disk) at low level, and is pulse modulated in accordance with binary data. If data to be recorded is a signal at a frequency of 1 MHz, the beam is radiated on the medium while being modulated at a frequency of 1 MHz. In this case, $H_{ini.} = 3,000$ Oe. Thus, a 1-MHz signal is recorded. In order to check a recorded state at this time, when data recorded in the second layer is reproduced with a beam power of 1.5 mW (on disk) using a normal magneto-optical reproduction apparatus, a reproduction signal having a C/N ratio of 53 dB can be obtained. Thus, it could be confirmed that data was recorded.

A signal having a frequency of 2 MHz is recorded as new data in a region of the medium in which data has already been recorded. When this data is reproduced similarly, new data is reproduced at a C/N ratio of 52 dB. In this case, no 1-MHz signal (previous data) appears at all.

As a result, it is found that the over-write operation can be performed.

Under this condition, the temperature of the medium reaches $T_H = 220^\circ$ C. at high level, and $T_L = 160^\circ$ C. at low level.

Another magneto-optical recording operation using the recording apparatus shown in FIG. 29 will be described below. A laser beam (8.9 mW (on disk) at high level; 5.7 mW (on disk) at low level) is radiated on a

recording medium (No. 2') of embodiment 2 which is moved at a speed of 8.5 m/sec while being modulated at a frequency of 1 MHz. In this case, $H_{ini.} = 3,500$ Oe. Thus, a 1-MHz signal is recorded.

The data is reproduced with a beam power of 1.5 mW (on disk). Thus, a reproduction signal having a C/N ratio of 52 dB can be obtained.

A signal at a frequency of 4 MHz is recorded as new data in a region of the medium in which data has already been recorded. When the data is reproduced similarly, new data is reproduced at a C/N ratio of 49 dB. In this case, no 1-MHz signal (previous data) appears at all.

As a result, it is found that the over-write operation can be performed.

Under this condition, the temperature of the medium reaches $T_H = 220^\circ$ C. at high level, and $T_L = 150^\circ$ C. at low level.

A magneto-optical recording operation using the recording apparatus shown in FIG. 31 will be described below. A laser beam (9.3 mW (on disk) at high level; 5.7 mW (on disk) at low level) is radiated on a recording medium (No. 2') of embodiment 2 which is moved at a speed of 8.5 m/sec while being modulated at a frequency of 2 MHz. Thus, a 2-MHz signal is recorded.

The data is reproduced with a beam power of 1.5 mW (on disk). Thus, a reproduction signal having a C/N ratio of 51 dB can be obtained.

A signal having a frequency of 3 MHz is recorded as new data in a region of the medium in which data has already been recorded. When the data is reproduced similarly, new data is reproduced at a C/N ratio of 50 dB. In this case, no 2-MHz signal (previous data) appears at all.

As a result, it is found that the over-write operation can be performed.

Under this condition, the temperature of the medium reaches $T_H = 230^\circ$ C. at high level, and $T_L = 150^\circ$ C. at low level.

What is claimed is:

1. A magneto-optical recording medium comprising: a substrate; and a perpendicular magnetic film provided on said substrate and having a multilayered structure including first and second layers; said first layer comprising a transition metal-heavy rare earth alloy which is heavy rare earth rich and has a compensation temperature between a room temperature and a Curie temperature, said second layer comprising a transition metal-heavy rare earth alloy which is heavy rare earth rich and has a compensation temperature between a room temperature and a Curie temperature, and said medium satisfying following formula (1):

$$T_R < T_{comp,1} < T_{C1} \approx T_L \approx T_{comp,2} < T_{C2} \approx T_H \quad (1)$$

and satisfying at the room temperature following formulas:

$$H_{C1} - \frac{\sigma_w}{2M_{S1}t_1} > H_{C2} + \frac{\sigma_w}{H_{S2}t_2} \cong |H_b| \quad (2)$$

$$H_{C1} > \frac{\sigma_w}{2M_{S1}t_1} \quad (3)$$

$$|H_b| > -H_{C2} + \frac{\sigma_w}{2M_{S2}t_2} > 0 \quad (4)$$

-continued

$$H_{C2} + \frac{\sigma_w}{2M_{S2}t_2} < |H_{ini.}| < H_{C1} - \frac{\sigma_w}{2M_{S1}t_1} \quad (5)$$

where T_R : room temperature
 $T_{comp.1}$: compensation temperature of first layer
 $T_{comp.2}$: compensation temperature of second layer
 T_{C1} : Curie temperature of first layer
 T_{C2} : Curie temperature of second layer
 T_L : temperature of recording medium when low-level laser beam is radiated
 T_H : temperature of recording medium when high-level laser beam is radiated
 H_{C1} : coersivity of first layer
 H_{C2} : coersivity of second layer
 M_{S1} : saturation magnetization of first layer
 M_{S2} : saturation magnetization of second layer
 t_1 : thickness of first layer
 t_2 : thickness of second layer
 σ_w : interface wall energy
 $H_{ini.}$: initial field
 H_b : bias field.

2. A magneto-optical recording medium comprising: 25
 a substrate; and
 a perpendicular magnetic film provided on said substrate and having a multilayered structure including first and second layer; said first layer comprising a transition metal-heavy rare earth alloy which is heavy rare earth rich and does not have a compensation temperature between a room temperature and a Curie temperature, said second layer comprising a transition metal-heavy rare earth alloy which is heavy rare earth rich and has a compensation temperature between the room temperature and the Curie temperature, and said medium satisfying following formula (1):

$$T_R < T_{C1} \approx T_L \approx T_{comp.2} < T_{C2} \approx T_H \quad (1)$$

and satisfying at the room temperature following Formulas:

$$H_{C1} - \frac{\sigma_w}{2M_{S1}t_1} > H_{C2} + \frac{\sigma_w}{2M_{S2}t_2} \cong |H_b| \quad (2)$$

$$H_{C1} > \frac{\sigma_w}{2M_{S1}t_1} \quad (3)$$

$$|H_b| > -H_{C2} + \frac{\sigma_w}{2M_{S2}t_2} > 0 \quad (4)$$

$$H_{C2} + \frac{\sigma_w}{2M_{S2}t_2} < |H_{ini.}| < H_{C1} - \frac{\sigma_w}{2M_{S1}t_1} \quad (5)$$

where T_R : room temperature
 $T_{comp.2}$: compensation temperature of second layer
 T_{C1} : Curie temperature of first layer
 T_{C2} : Curie temperature of second layer
 T_L : temperature of recording medium when low-level laser beam is radiated

T_H : temperature of recording medium when high-level laser beam is radiated
 H_{C1} : coersivity of first layer
 H_{C2} : coersivity of second layer
 M_{S1} : saturation magnetization of first layer
 M_{S2} : saturation magnetization of second layer
 t_1 : thickness of first layer
 t_2 : thickness of second layer
 σ_w : interface wall energy
 $H_{ini.}$: initial field
 H_b : bias field.

3. A magneto-optical recording medium comprising: 30
 a substrate; and
 a perpendicular magnetic film provided on said substrate and having a multilayered structure including first and second layers;
 said first layer comprising a transition metal-heavy rare earth alloy which is transition metal rich and does not have a compensation temperature between a room temperature and a Curie temperature, said second layer comprising a transition metal-heavy rare earth alloy which is heavy rare earth rich and has a compensation temperature between the room temperature and the Curie temperature, and said medium satisfying following formula (1):

$$T_R < T_{C1} \approx T_L \approx T_{comp.2} < T_{C2} \approx T_H \quad (1)$$

and satisfying at the room temperature following Formulas:

$$H_{C1} + \frac{\sigma_w}{2M_{S1}t_1} > H_{C2} + \frac{\sigma_w}{2M_{S2}t_2} \cong |H_b| \quad (2)$$

$$H_{C1} - H_{C2} > \frac{\sigma_w}{2M_{S1}t_1} - \frac{\sigma_w}{2M_{S2}t_2} \quad (2-2)$$

$$H_{C1} > \frac{\sigma_w}{2M_{S1}t_1} \quad (3)$$

$$|H_b| > -H_{C2} + \frac{\sigma_w}{2M_{S2}t_2} > 0 \quad (4)$$

$$H_{C2} + \frac{\sigma_w}{2M_{S2}t_2} < |H_{ini.}| < H_{C1} + \frac{\sigma_w}{2M_{S1}t_1} \quad (5)$$

where T_R : room temperature
 $T_{comp.2}$: compensation temperature of second layer
 T_{C1} : Curie temperature of first layer
 T_{C2} : Curie temperature of second layer
 T_L : temperature of recording medium when low-level laser beam is radiated
 T_H : temperature of recording medium when high-level laser beam is radiated
 H_{C1} : coersivity of first layer
 H_{C2} : coersivity of second layer
 M_{S1} : saturation magnetization of first layer
 M_{S2} : saturation magnetization of second layer
 t_1 : thickness of first layer
 t_2 : thickness of second layer
 σ_w : wall energy
 $H_{ini.}$: initial field
 H_b : bias field.

* * * * *