

Portable MiniDisc Recorder

Operating Instructions

Recorder Operation _____ **page 8**

Troubleshooting and explanations _____ **page 48**



MDLP **DPC** *TYPE-S*

MZ-B10

Caution

The use of optical instruments with this product will increase eye hazard.

**CAUTION — INVISIBLE LASER
RADIATION WHEN OPEN
AVOID EXPOSURE TO BEAM**

Certain countries may regulate disposal of the battery used to power this product. Please consult with your local authority.

Information

IN NO EVENT SHALL SELLER BE
LIABLE FOR ANY DIRECT,
INCIDENTAL OR
CONSEQUENTIAL DAMAGES OF
ANY NATURE, OR LOSSES OR
EXPENSES RESULTING FROM
ANY DEFECTIVE PRODUCT OR
THE USE OF ANY PRODUCT.

The validity of the CE marking is restricted to only those countries where it is legally enforced, mainly in the countries EEA (European Economic Area).

For customers who purchased this product in the USA

Owner's Record

The serial number is located at the inside of the battery compartment and the model number is located at the front of the lid. Record the serial number in the space provided below. Refer to them whenever you call upon your Sony dealer regarding this product.

Model No. MZ-B10

Serial No. _____

Product registration

Please register this product on line at www.sony.com/productregistration
<<http://www.sony.com/productregistration>>

Proper registration will enable us to send you periodic mailings about new products, services and other important announcements. Registering your product will also allow us to contact you in the unlikely event that the product needs adjustment or modification.

Thank you.

This equipment has been tested and found to comply with the limits for a Class B digital device, pursuant to Part 15 of the FCC Rules. These limits are designed to provide reasonable protection against harmful interference in a residential installation. This equipment generates, uses, and can radiate radio frequency energy and, if not installed and used in accordance with the instructions, may cause harmful interference to radio communications. However, there is no guarantee that interference will not occur in a particular installation. If this equipment does cause harmful interference to radio or television reception, which can be determined by turning the equipment off and on, the user is encouraged to try to correct the interference by one or more of the following measures:

- Reorient or relocate the receiving antenna.
- Increase the separation between the equipment and receiver.
- Connect the equipment into an outlet on a circuit different from that to which the receiver is connected.
- Consult the dealer or an experienced radio/TV technician for help.

You are cautioned that any changes or modifications not expressly approved in this manual could void your authority to operate this equipment.

Table of contents

Looking at the controls	9
-------------------------------	---

Preparing a power source	12
--------------------------------	----

Recording an MD right away!	13
-----------------------------------	----

Playing an MD right away!	16
---------------------------------	----

Various ways of recording	18
Long-time recording (MDLP)	18
Recording from a stereo microphone	19
Recording from externally connected equipment	20
Recording with digital (optical) input (Digital Recording)	21
Recording from a TV or radio (Analog Recording)	22
To start/stop recording in sync with the sound source (Synchro-recording)	23
Adding track marks while recording	24
Adding track marks manually	24
Adding track marks automatically (Auto Time Mark)	24

Various ways of playback	26
Changing the sound mode	26
Changing playback speed (Speed Control)	26
Selecting the play mode (Single Play/Repeat Play)	27

Editing recorded tracks	29
Adding a track mark	29
Erasing a track mark	29
Moving recorded tracks (Move)	30
Erasing tracks (Erase)	31
To erase a track	31
To erase the whole disc	31

Using the group function	32
Using the group function	32
Using the group function when recording	32
Recording tracks to a new group	32
Recording a track to an existing group	33
Using the group function when playing	33
Playing a track in group play	33
Editing groups	34
Assigning tracks or groups as a new group (Group Setting)	34
To release a group setting	35
Moving a track in a disc with group setting	35
Changing the order of a group on a disc (Group Move)	36
To erase a group	37

Other operations	38
Useful settings	38
How to use the menu items	38
Creating a new group when recording	39
To select microphone sensitivity	39
Starting an operation quickly (Quick Mode)	40
Using an optional foot control unit	40
List of menus	41

Power sources	42
When to replace the batteries	42
Battery life	42
Using house current	43

Additional information	44
Precautions	44
Specifications	47

Troubleshooting and explanations	48
Troubleshooting	48
While recording	48
While playing	50
While Editing	51
While using group function	52
Others	52
Messages	53
Explanations	56

Checking the supplied accessories

Headphones/earphones (1)

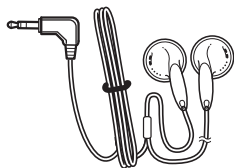

Carrying pouch (1)



Handstrap (1)

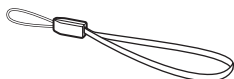

Clamp filter for the AC power adaptor (1)
Attach the clamp filter when using the optional AC power adaptor.

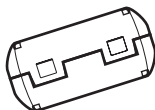

LR6 (size AA) alkaline dry
batteries (2) (World model only)

When using the optional AC power adaptor

Before using the AC power adaptor, do the following procedure to attach the clamp filter to the cord of the AC power adaptor. (You must affix the ferrite cores to comply with applicable EMC standards.)

① Open the clamp filter.

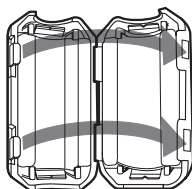

② Wind the AC power cord into the clamp filter as shown below.

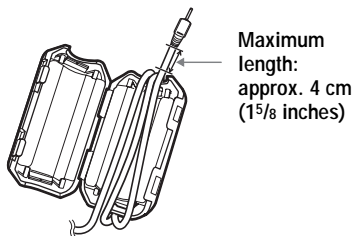

③ Close the clamp filter.

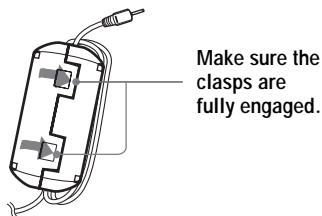

Looking at the controls

See pages in () for more details.

Front of the recorder

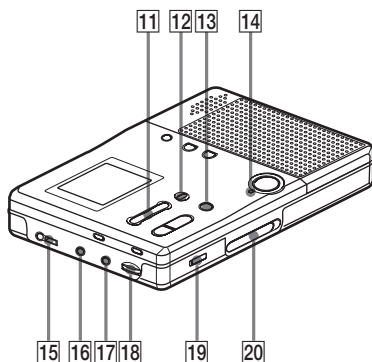
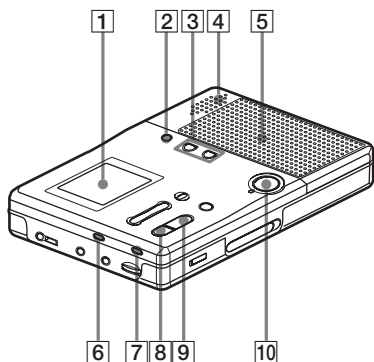

- 1** Display window (23) (26) (30) (34)
- 2** MENU/ENTER button (23) (26) (30) (34) (38)
You can use various settings using menu items.
- 3** SPEED CONTROL +, - button (26)
Use this button to increase or decrease the playback speed.
- 4** Built-in microphone (14)
- 5** Speakers (16)
- 6** REC MODE button (14) (18)
Use this button to select 2 times normal (LP2 or monaural) or 4 times (LP4) the normal (SP) recording time.
- 7** GROUP button (32)
This button is used when cueing to a group or erasing a group.
- 8** ■ • STOP button (14) (16) (23) (30) (38)
- 9** ► • PLAY (play) button (15) (16)
The ► • PLAY button has a tactile dot.
- 10** REC button (14) (18) (32)
- 11** ◀◀ • REVIEW • AMS, ▶▶ • CUE • AMS (search /AMS) buttons (15) (17) (23) (26) (29) (33) (38)
- 12** TRACK MARK button (29)
Use this button to add track marks automatically or to divide a track into separate tracks.
- 13** || • PAUSE button (15) (17) (29)
- 14** REC indicator (14) (15)
Lights up while recording.
- 15** Ⓞ (headphones/earphones) jack (14) (16)
Connect headphones or earphones to this jack.

16 MIC (PLUG IN POWER) jack (19)
Connect an optional stereo microphone to this jack to record. The MIC (PLUG IN POWER) jack has a tactile dot.

17 LINE IN (OPTICAL) jack (21) (22)
Connect an optional optical or line cable to this jack to record from a CD, etc.

18 VOL control (16)
The VOL control has a tactile dot.

19 HOLD switch (12)
Slide the switch in the direction of the arrow to disable the buttons on the recorder. To prevent the buttons from being accidentally operated when you carry the recorder, use this function.

20 OPEN switch (13) (16)

Back of the recorder

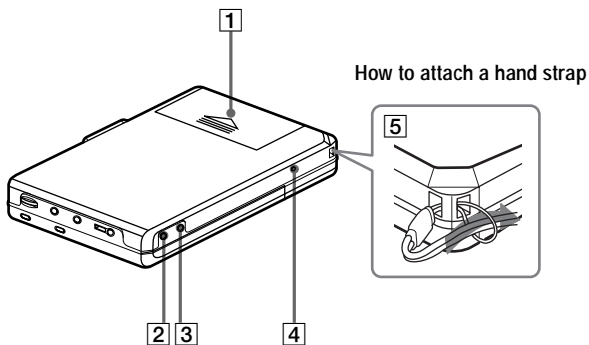

1 Battery compartment (12)
Insert two alkaline dry batteries (size AA) here.

2 ERASE button (31) (37)
During playback, press this button to erase the track.

3 ALL ERASE button (31)
Press ERASE while pressing this button to erase the contents of an entire disc.

4 DC IN 3V jack (43)
When you connect an optional AC power adaptor, connect it to this jack.

5 Handstrap hole

The display window

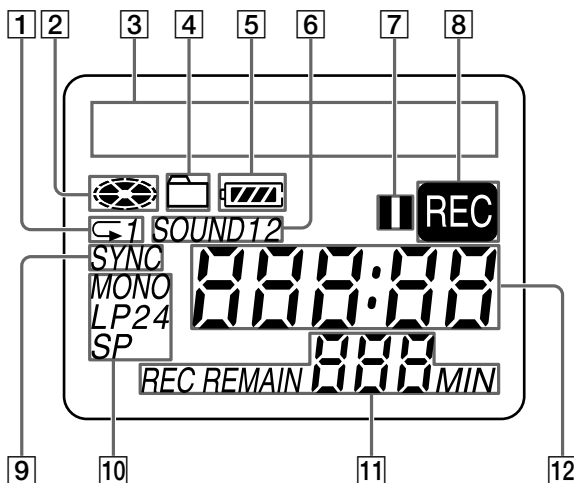

- 1** Play mode indication (28)
Lights up when selecting specific play mode.
- 2** Disc indication (18) (26) (30) (34)
Shows that the disc is rotating for recording, playing or editing an MD.
- 3** Character information display (18) (26) (30) (34)
Displays the disc and track names, error messages, track numbers, etc.
- 4** Group indication (33)
Lights up while in group play. Flashes while selecting a group.
- 5** Battery level indication (42)
- 6** SOUND indication (26)
Lights up when the sound mode (SOUND 1, SOUND 2) is selected.
- 7** Pause indication
- 8** REC indication (14)
- 9** SYNC (synchro-recording) indication (23)
- 10** SP, LP2, LP4, MONO indication (18)
Shows the recording mode while recording and SP/LP mode of a track while playing.
- 11** REC REMAIN indication (18)
Shows the remaining recordable time in a disc while recording or stopped.
- 12** Time indication (18) (26) (30) (34)
Shows the elapsed time while recording or playing.

Preparing a power source

This section explains how to prepare the recorder for battery-powered operation. For information on connecting the recorder to an AC power outlet, see page 43.

1 Insert dry batteries.

Back of the recorder

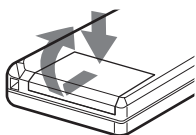

Press and slide the battery compartment lid as shown in the illustration.

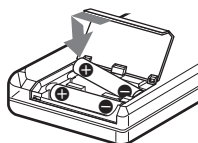

Insert two LR6 (size AA) alkaline dry batteries (supplied with the world model only).

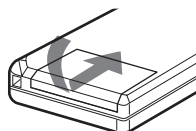

Close the lid.

Notes

- Do not use manganese dry battery. If you do, recording may not be possible.
- Insert the \oplus and \ominus poles of the battery correctly as shown on the recorder.

2 Unlock the control.

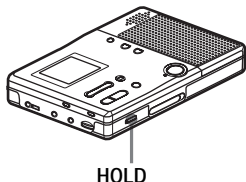

Slide HOLD to the opposite direction of the arrow on the recorder.

Recording an MD right away!

Use the built-in microphone to record. Make sure the record-protect tab on the disc is closed (page 46). The use of new alkaline dry batteries is recommended. The recording may not be possible if you use manganese dry batteries.

1 Insert a recordable MD.

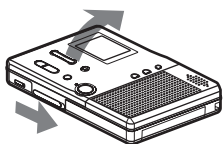

- ① Slide OPEN to open the lid.

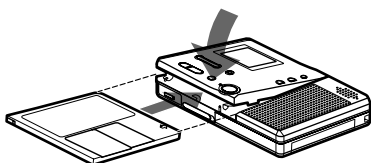

- ② Insert a recordable MD to the direction of the arrow with the label side facing up, and press down on the lid (at the center of the front edge as shown above) to close it firmly.

2 Select microphone sensitivity.

The recorder is factory set to record material with a normal volume level (“SENS HIGH”), such as conversations. When recording a sound source at close range, such as a narration, set the microphone sensitivity to “SENS LOW” (see page 39 for details).

3 Select the recording mode.

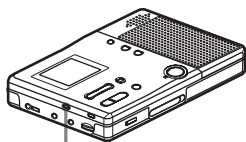

REC MODE

You can select SP, LP2, LP4, or monaural (see page 18 for details). The recorder is factory set to LP4. Change the recording mode if necessary.

4 Record an MD.

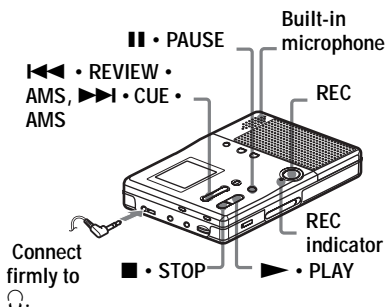

① Press REC.

“REC” appears, REC indicator lights up, and then recording starts.

You can monitor the recording conditions, such as the recording position, through the display or the REC indicator.

If the disc is blank, the recording starts from the beginning. If the disc is partially recorded, the recording automatically starts from the end of the existing material.

To stop recording, press ■ • STOP.

After you press the ■ • STOP button to stop the recorder, the recorder will automatically turn off after about 30 seconds (when using an alkaline dry battery) or 5 minutes (when using the AC power adaptor).

To monitor the sound during recording.

Connect the headphones/earphones to the  jack. You can adjust the volume by turning the VOL control. This adjustment does not affect the recording level since the level is adjusted automatically.

To	Operation
Record partway through the previous recording	Press ► • PLAY, ►► • CUE • AMS or ◀◀ • REVIEW • AMS to find the beginning of the material to be recorded, and then press ■ • PAUSE. Press REC so that the recorder changes to recording pause. Press ■ • PAUSE again to start recording.
Pause ¹⁾	Press ■ • PAUSE while recording. Press ■ • PAUSE again to resume recording.
Remove the MD	■ • STOP to stop recording, check if “TOC Edit” has disappeared from the display, and then open the lid.

¹⁾The REC indicator flashes during recording pause. Track marks are not added while recording with microphone, even when the recorder is paused.

If the recording does not start

- Make sure the recorder is not locked (page 12).
- Make sure the MD is not record-protected (page 46).
- Premastered MDs cannot be recorded over.

To know the recording condition

The REC indicator lights up or flashes according to the recording condition.

Recording condition	REC indicator
While recording	lights up flashes according to the loudness of the source while recording with a microphone (voice mirror)
Recording standby	flashes
Less than 3 minutes' recording time available	flashes slowly
A track mark has been added ¹⁾	goes off momentarily

¹⁾ Except when track marking was done manually or automatically using Auto Time Mark (page 24).

Notes

- For long recordings, it is recommended that you power the recorder from a house current using an optional AC power adaptor AC-E30HG (page 43).
- The lid will not open during recording or until “TOC Edit” disappears from the display after the recording has completed.
- If the power supply is disrupted (i.e. the batteries are removed or becomes exhausted or the optional AC power adaptor is disconnected) during a recording operation, or while “TOC Edit” appears in the display, then it will not be possible to open the lid until power is restored.
- “Data Save” or “TOC Edit” flashes while data of the recording (the track’s start and end points, etc.) is being recorded. Do not move or jog the recorder or disconnect the power source while the indication is flashing in the display. If you do, the material recorded up to that point will not be saved to the disc.
- When you record through the microphone, the various sounds made by the recorder may also be recorded.
- The built-in microphone do not operate whenever an optional microphone is connected into the MIC (PLUG IN POWER) jack on the recorder.
- The built-in microphone do not operate whenever an optical cable or a line cable (not supplied) is connected into the LINE IN (OPTICAL) jack on the recorder.

Playing an MD right away!

You can play recordable MDs or premastered MDs. Sound output from the built-in speaker is monaural, but stereo listening is possible through the supplied headphones/earphones.

1 Insert an MD.

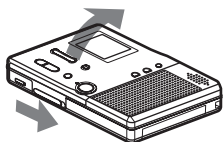

- ① Slide OPEN to open the lid.

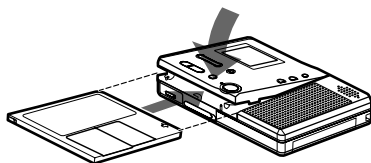

- ② Insert an MD to the direction of the arrow with the label side facing up, and press down on the lid (at the center of the front edge as shown above) to close it firmly.

2 Play an MD.

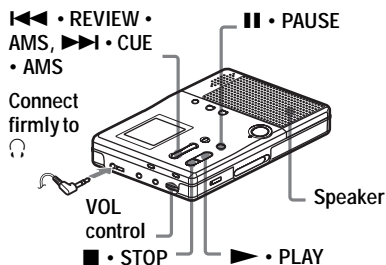

- ① Press ▶ • PLAY.
- ② Turn VOL to adjust the volume.

To stop play, press ■ • STOP.

Playback starts from the point you last stopped playing. To start playback from the beginning of the disc, press ▶ • PLAY for 2 seconds or more.

After you press the ■ • STOP button to stop the recorder, the recorder will automatically turn off after about 30 seconds (when using an alkaline dry battery), or 5 minutes (when using the AC power adaptor).

To listen in stereo

Connect the headphones/earphones to the jack on the recorder.

To	Operation on the recorder
Pause	Press II • PAUSE. Press II • PAUSE again to resume play.
Cue to the current track or a previous track ¹⁾	Press ◀◀ • REVIEW • AMS. Press ◀◀ • REVIEW • AMS repeatedly until you reach the beginning of the desired track.
Cue to the next track ²⁾	Press ▶▶ • CUE • AMS.
Go backwards or forward while playing	Press and hold ◀◀ • REVIEW • AMS or ▶▶ • CUE • AMS.
Search for a point in a track while viewing the elapsed time. (Time search)	During pause, press and hold ◀◀ • REVIEW • AMS or ▶▶ • CUE • AMS.
Search for a specific track while viewing track numbers or track names. (Index search)	While the recorder is stopped, press and hold ◀◀ • REVIEW • AMS or ▶▶ • CUE • AMS.
Remove the MD	Press ■ • STOP and open the lid. ³⁾

¹⁾ If you press **◀◀** • REVIEW • AMS during the first track of the disc, the recorder goes to the beginning of the last track on the disc.

²⁾ If you press **▶▶** • CUE • AMS during the last track of the disc, the recorder goes to the beginning of the first track on the disc.

³⁾ Once you open the lid, the point to start play will change to the beginning of the first track.

If the play does not start

Make sure the recorder is not locked (page 12).



Playback will switch automatically between stereo and monaural according to the sound source.

Notes

- The sound may skip during playback when the recorder is exposed to continuous vibration, such as while jogging.
- If the power supply is disrupted (i.e. the batteries are removed or become exhausted or the optional AC power adaptor is disconnected) when the recorder is operating, the lid may not open until the power is restored.

Long-time recording (MDLP)

Select each recording mode according to the recording time that you want. Stereo recording is possible at 2 times (LP2) or 4 times (LP4) the normal (SP) recording time. Monaural recording at 2 times normal recording time is also possible.

MDs recorded in monaural or MDLP mode can be played back only on MD players or recorders with monaural or MDLP playback mode.

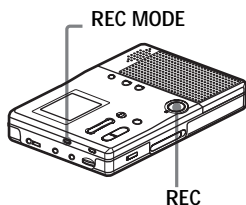

- 1 Insert a recordable disc.
- 2 Press REC MODE repeatedly until desired recording mode lights up in the display.

Each time you press the button, **A** changes as follows.

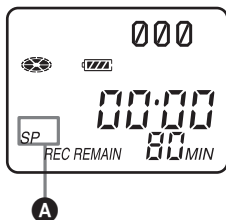

Recording mode ¹⁾	A	Recording time ²⁾
SP	SP	approx. 80 min.
LP2	LP2	approx. 160 min.
LP4	LP4	approx. 320 min.
Monaural	MONO	approx. 160 min.

¹⁾ For better sound quality, record in SP or LP2 mode.

²⁾ When using an 80-minute recordable MD

3 Press REC.

For other operations on recording, see “Recording an MD right away!” (page 13).



- If you record in SP, LP2, or LP4 mode using an externally connected stereo microphone (not supplied) or other stereo equipment connected to the LINE IN (OPTICAL) jack, the recording will be stereo. If you record with the built-in microphone, the recording will be monaural (the same sound is recorded to the left and right channels).
- The recording mode can be changed during recording pause. When you change the recording mode, a track mark is automatically added at that point.
- Audio components that support the LP2 or LP4 modes are indicated by the **MDLP** or **MDLP** logo marks.

Notes

- It is recommended that you use the AC power adaptor (not supplied) for long recordings.
- During monaural recording of a stereo sound source connected through the digital (optical) input jack, you can still monitor the recorded sound in stereo by using headphones/earphones connected to the  jack.
- When you record in LP4 mode, momentary noise may be produced on very rare occasions with certain sound sources. This is because of the special digital audio compression technology that enables a recording time 4 times longer than normal. If noise is produced, it is recommended that you record in SP or LP2 mode to obtain better sound quality.

Recording from a stereo microphone

Connect a stereo microphone (ECM-719, etc.) to the MIC (PLUG IN POWER) jack. The recorder input automatically switches to the externally connected microphone input.

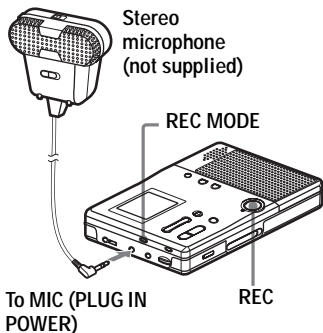

- 1 Insert a recordable disc and select the microphone sensitivity.
See “To select microphone sensitivity” (page 39).

- 2 Press REC MODE repeatedly until “SP”, “LP2”, “LP4”, or “MONO” lights up in the display.
For details on the recording mode, see “Long-time recording (MDLP)” (page 18).
- 3 Press REC.
For other operations on recording, see “Recording an MD right away!” (page 13).



When using a plug-in power-type microphone, the microphone can be operated even when its power switch is turned off since power is supplied from the recorder itself.

If you are using the optional stereo microphone ECM-719, set the power switch on the microphone to OFF to allow the recorder to provide power to the microphone. It is recommended that you set the switch on the microphone to OFF during use.

Notes

- You cannot record through the externally connected microphone while an optical cable is connected to the LINE IN (OPTICAL) jack. The recorder automatically selects the recorder input in the following order of priority; optical input, externally connected microphone input, analog (line) input, and built-in microphones input.
- The microphone may pick up the operating sound of the recorder itself (such as the sound of the motor). Use the microphone away from the recorder in such cases. Please note that the sound of recorder operations may be picked up if the microphone that you use has a short connector.

Recording from externally connected equipment

The LINE IN (OPTICAL) jack of this recorder works as both digital and analog input jacks. Connect the recorder to a CD player or a cassette recorder using either digital (optical) input or analog (line) input. To record, see “Recording with digital (optical) input (Digital Recording)” (page 21) to record using digital (optical) input and “Recording from a TV or radio (Analog Recording)” (page 22) to record using analog (line) input.

LINE IN (OPTICAL) jack is for both digital and analog input.

The recorder automatically recognizes the type of line cable and switches to digital or analog input.

Difference between digital (optical) and analog (line) inputs

Difference	Digital (optical) input	Analog (line) input
Connectable source	Equipment with an digital (optical) output jack	Equipment with an analog (line) output jack
Usable cord	Optical cable (with an optical or an optical-mini plug) (page 21)	Line cable (with 2 phono plugs or a stereo-mini plug) (page 22)
Signal from the source	Digital	Analog Even when a digital source (such as a CD) is connected, the signal sent to the recorder is analog.
Recorded track numbers	Marked (copied) automatically <ul style="list-style-type: none">• at the same positions as the source (when the sound source is a CD or an MD).• after more than 2 seconds of blank or low-level segment (with a sound source other than a CD or an MD) (page 56).• when the recorder is paused while recording (the recorder pauses automatically when it encounters a section with no audio signal for 3 seconds or more) (page 56). You can erase unnecessary marks after recording. (“Erasing a track mark”, page 29).	Marked automatically <ul style="list-style-type: none">• after more than 2 seconds of blank or low-level segment.• when the recorder is paused while recording. You can erase unnecessary marks after recording (“Erasing a track mark”, page 29).
Recorded sound level	Same as the source.	Adjusted automatically.

Note

Track marks may be copied incorrectly:

- when you record from some CD players or multi disc players using digital (optical) input.
- when the source is in shuffle or program play mode while recording using digital (optical) input. In this case, play the source in normal play mode.
- when programs with audio that is digitally broadcast (e.g., digital TV) are recorded.

Recording with digital (optical) input (Digital Recording)

Connect to a digital source using an optical cable to make digital recordings. Digital recording is possible even from digital equipment with different sampling rates, such as a DAT deck or a BS tuner, using the built-in sampling rate converter.

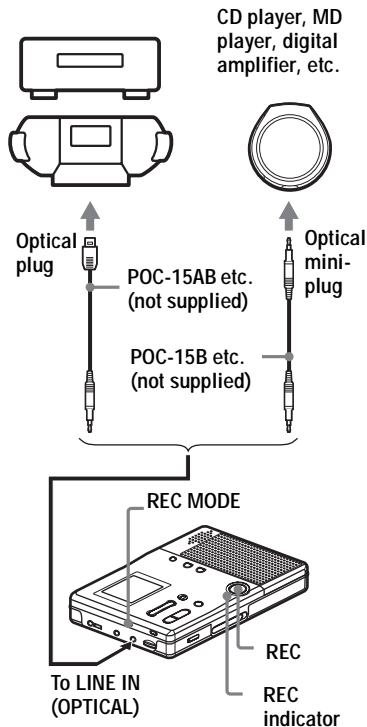

1 Insert a recordable disc.

2 Press REC MODE repeatedly until “SP”, “LP2”, “LP4”, or “MONO” lights up in the display.

For details on the recording mode, see “Long-time recording (MDLP)” (page 18).

3 Press REC.

“REC” appears in the display, the REC indicator lights up, and the recording starts.

4 Play the source sound.

For other operations on recording, see “Recording an MD right away!” (page 13).



- When recording from digital media, track marks in the original are copied automatically to the MD.
- Synchro-recording is useful for making digital recordings. During synchro-recording, the starting and stopping of recording is done automatically and in sync with the source material.

Notes

- You can make a digital recording with an optical cable only from an optical type output.
- Note the following when recording from a portable CD player.
 - Some portable CD players may not be capable of digital out when the AC power adaptor is disconnected. If this is the case, connect the AC power adaptor to the portable CD player and use it on AC power as the power source.
 - Digital output may be disabled on some portable CD players when the AC power adaptor is not connected to the player.
 - Turn off the anti-skip function (e.g., ESP* or G-PROTECTION).
- A track mark is added at the point where you press the **||** • PAUSE button again to resume recording while pausing recording; thus the remainder of the track will be counted as a new track.

* Electronic Shock Protection

Recording from a TV or radio (Analog Recording)

Connect the recorder with a line cable (not supplied) to make analog recording. Connect firmly to the appropriate jacks.

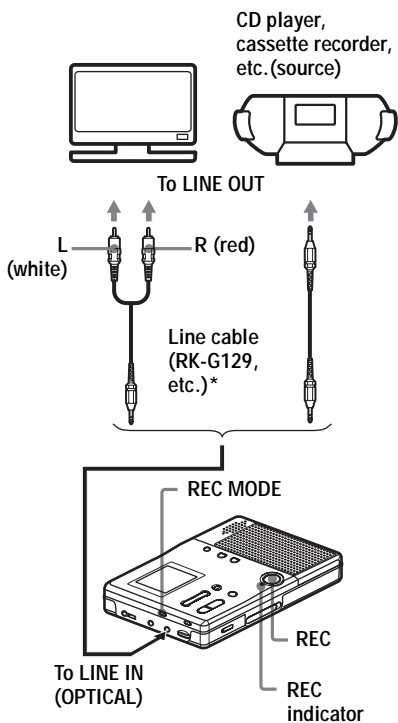

* To connect to a portable CD player having a stereo mini-jack, use the RK-G136 connecting cord (not supplied).

Note

Use the connecting cords without an attenuator.

- 1 Insert a recordable disc.

- 2 Press REC MODE repeatedly until "SP", "LP2", "LP4", or "MONO" lights up in the display.

For details on the recording mode, see "Long-time recording (MDLP)" (page 18).

- 3 Press REC. "REC" appears in the display, the REC indicator lights up, and the recording starts.

- 4 Play the source sound.

For other operations on recording, see "Recording an MD right away!" (page 13).

Note

A track mark is added at the point where you press the **II** • PAUSE button again to resume recording while pausing recording; thus the remainder of the track will be counted as a new track.

To start/stop recording in sync with the sound source (Synchro-recording)

During synchro-recording, the starting and stopping of recording occurs are synchronized with the sound source. This simplifies digital recordings (e.g., from a CD player) since the need to operate the recorder or the sound source is eliminated. Synchro-recording is only possible with the optical cable connected.

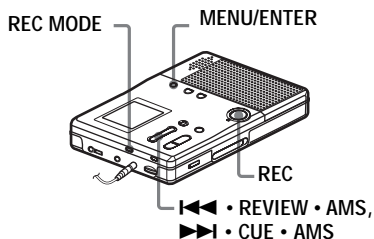

- 1 Press REC MODE repeatedly until “SP”, “LP2”, “LP4”, or “MONO” lights up in the display.
For details on the recording mode, see “Long-time recording (MDLP)” (page 18).
- 2 Press MENU/ENTER.
- 3 Press ◀◀ or ▶▶ until “REC SET” appears in the display, and then press MENU/ENTER.
- 4 Press ◀◀ or ▶▶ until “SYNC REC” appears in the display, and then press MENU/ENTER.

- 5 Press ◀◀ or ▶▶ until “SYNC ON” appears in the display, and then press MENU/ENTER.

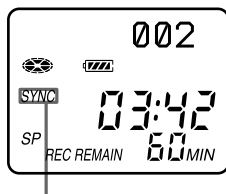

Synchro-recording indication

“SYNC” appears in the display. “SYNC” doesn’t appear if optical cable is not connected to the LINE IN (OPTICAL) jack on the recorder.

- 6 Press REC.
The recorder stands by for recording.
- 7 Play the source sound.
The recorder starts recording automatically when it receives the playing sound.

To stop recording

Press ■ • STOP.



When there is no sound from the player for more than 3 seconds during synchro-recording, the recorder goes into the standby mode automatically (page 56). When the sound comes from the player again, the recorder resumes synchro-recording. If the recorder is kept in the standby mode for 5 minutes or longer, the recorder stops automatically.

Notes

- The pause function cannot be turned on or off manually during synchro-recording.
- Do not switch the “SYNC REC” setting while recording. Recording may not be done properly.
- You cannot change the recording mode during recording.
- Even when there is no sound on the sound source, there may be cases when recording does not pause automatically during synchro-recording due to the noise level emitted from the sound source.
- If a silent portion is encountered for approximately 2 seconds during synchro-recording from a sound source other than a CD or an MD, a new track mark is automatically added at the point where the silent portion ends.
- Synchro-recording cannot be done if the connecting cord is not an optical cable, or if the cable is connected to the MIC (PLUG IN POWER) jack.

Adding track marks while recording

You can add track marks (track number) while recording to divide the material into separate parts.

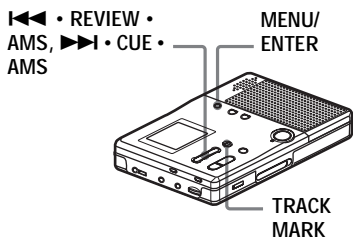

Adding track marks manually

- 1 While the recorder is recording, press TRACK MARK.

Adding track marks automatically (Auto Time Mark)

Use this feature to add track marks automatically at 10-minute intervals when recording through the analog input connector or a microphone. This function is convenient when making a long recording, e.g., of a lecture or meeting.

- 1 While the recorder is recording or in recording pause, press MENU/ENTER.
- 2 Press **◀◀** or **▶▶** until “REC SET” appears in the display, and then press MENU/ENTER.
- 3 Press **◀◀** or **▶▶** until “TIME MARK” appears in the display, and then press MENU/ENTER.

- 4 Press **◀◀** or **▶▶** until “MARK ON” appears in the display, and then press MENU/ENTER.

“10min.ON” appears in the display and the selection is entered.

“T” appears after the track number in the display.

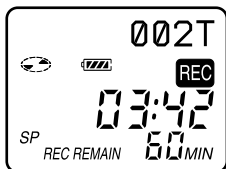

To cancel Auto Time Mark
Select “MARK OFF” in step 4 or stop recording.

Using Auto Time Mark to add track marks while recording

When the elapsed recording time exceeds 10 minutes:

The recorder adds a track mark at the point when Auto Time Mark is set, and at each 10-minute interval thereafter.

Example: When 12 minutes of recording has been completed when the Auto Time Mark is set.

A track mark will be added at the 12-minute point (following the start of recording) and after each 10-minute interval thereafter.

When the time interval for Auto Time Mark (10 minutes) exceeds the elapsed recording time:

The recorder adds a track mark when 10 minutes has elapsed.

Example: When 3 minutes of recording has been completed when the Auto Time Mark is set.

A track mark will be added at the 10-minute point (following the start of recording) and after each 10-minute interval thereafter.

Note

The setting will be lost when the recording stopped.

Changing the sound mode

You can select the sound mode during playback. This function emphasizes voices, so it is useful when listening to recordings of meetings or lectures.

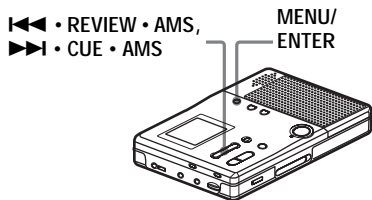

- 1 Press MENU/ENTER.
- 2 Press ◀◀ or ▶▶ until "SOUND" appears in the display, and then press MENU/ENTER.
- 3 Press ◀◀ or ▶▶ repeatedly until your desired sound setting appears in the display, and then press MENU/ENTER.

Each time you press the button, **A** changes as follows.
When you press MENU/ENTER, the sound indication lights up.

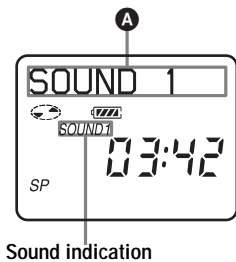

A	Sound setting
SOUND OFF	Factory setting
SOUND 1	Emphasizes voices.
SOUND 2	Emphasizes voices more strongly than SOUND 1.

To cancel the sound setting
Select "SOUND OFF" in step 3.

Notes

- If sound distortion occurs when you turn the volume up while "SOUND 1" or "SOUND 2", turn the volume down again or change the sound setting.
- The setting of "SOUND 1" or "SOUND 2" does not affect the sound being recorded.
- You cannot change the sound mode while the playback speed is changed.

Changing playback speed (Speed Control)

The speed control function is useful when you want to change the playback speed. This function changes the playback speed without changing the playback pitch (DPC*).

The playback speed can be varied from +100% to -50% the normal speed, in 13 steps.

* DPC stands for Digital Pitch Control.

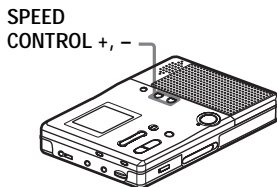

- 1 While playing, press SPEED CONTROL + or – while the recorder is playing.

Playback speeds up when you press the SPEED CONTROL + button and slows down when you press the – button. Select the desired playback speed while listening to the material. “DPC” appears in the display when the playback speed is changed.

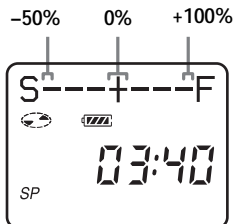

“DPC” appears when playback speed is changed.



To switch to normal playback Press ► • PLAY or SPEED CONTROL + or – to select 0%.



- Once you open the lid, the playback speed reverts to the normal speed (0%).
- While using this function, you can pause playback or locate track marks by pressing the ■ • PAUSE, ◀◀ • REVIEW • AMS, or ▶▶ • CUE • AMS button.

Notes

- When using this function, you may hear noise or an echo in the playback.
- When you change the playback speed, the sound mode setting (“SOUND 1” or “SOUND 2”) will stop functioning. When you change the playback speed back to normal (0%), the sound mode setting will begin functioning again.

Selecting the play mode (Single Play/ Repeat Play)

You can select single play, single repeat, or all repeat.

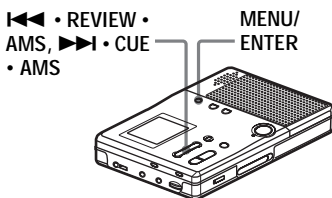

- 1 While playing, press MENU/ENTER.
- 2 Press ◀◀ or ▶▶ until “PLAY MODE” appears in the display, and then press MENU/ENTER.
- 3 Press ◀◀ or ▶▶ repeatedly until “Normal” or “1 Track” appears in the display, and then press MENU/ENTER.

Normal: All tracks are played once.

1 Track: A single track is played once.

- 4 Press **◀◀** or **▶▶** repeatedly until “RepeatOFF” or “RepeatON” appears in the display, and then press MENU/ENTER.

RepeatOFF: Playback will not repeat.

RepeatON: Playback will repeat with the play mode selected in step 3. When the selection enters, play mode indication lights up.

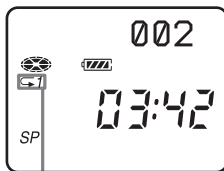

Play mode indication

Indication	Selected play mode
—	“Normal” and “RepeatOFF” (normal play)
1	“1 Track” and “RepeatOFF” (A single track is played.)
↶	“Normal” and “RepeatON” (All the tracks are played repeatedly.)
↶ 1	“1 Track” and “RepeatON” (A single track is played repeatedly.)

Note

Group play mode (⏮) in step 3 whenever you play a disc with group settings. For more details, see “Playing a track in group play” (page 33).

Editing recorded tracks

You can edit your recordings by adding/erasing track marks or changing the order of the recorded tracks.

Notes

- Premastered MDs cannot be edited.
- Close the record-protect tab on the side of the MD before editing
- When "TOC Edit" is flashing, the editing results are being recorded.
 - Do not move or jog the recorder.
 - Do not disconnect the power source.
 - The lid becomes locked.

Adding a track mark

You can add track marks so that the part after the new track mark is counted as a new track. A total of 254 track marks can be added on one disc. The track numbers will increase as follows.

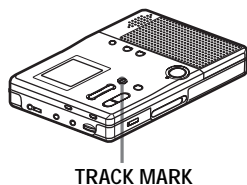
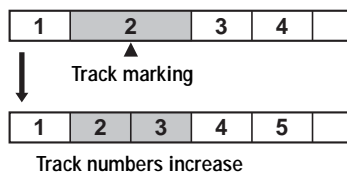

- 1 While recording, playing or pausing an MD, press TRACK MARK at the point you want to mark.
"MARK ON" appears in the display, and a track mark is added. The track number will increase by one.

Erasing a track mark

When you erase a regular track mark, the track numbers will change as follows.

Example

When combining track 2 and track 3

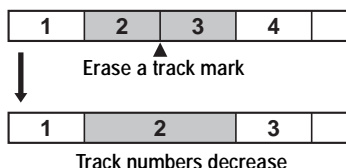

TRACK MARK

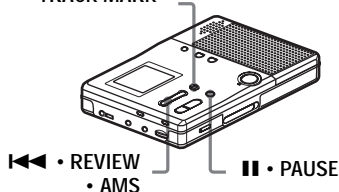

- 1 While playing the track with the track mark you want to erase, press || • PAUSE to pause.
To erase the third track mark, play the third track and press || • PAUSE.
- 2 Find the track mark by pressing ◀◀ slightly.
Find the beginning of the third track. "00:00" appears in the display. "MARK" appears in the display for 2 seconds.
- 3 Press TRACK MARK to erase the mark.
"MARK OFF" appears in the display. The track mark is erased and the two tracks are combined.



When you erase a track mark, the settings assigned to the mark are also erased.

Notes

- When you erase a track mark between the two consecutive tracks that are registered to different groups, the second track is re-registered into the group containing the first track. In addition, if you combine a track that is registered to a group with a track that is not (consecutive tracks), the second track takes the same registration setting as the first track. For example, if the first track is registered to a group, the second track will be registered to the same group as the first track.
- You cannot erase track marks according to the system limitations.

Moving recorded tracks (Move)

You can change the order of the recorded tracks.

Note

To move tracks in a disc with group settings, see page 35.

Example

Move track C from the third to the second track.

Before moving

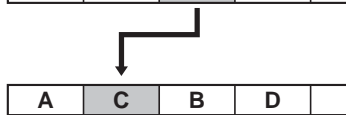

After moving

- ◀◀ • REVIEW
• AMS, ▶▶ •
CUE • AMS

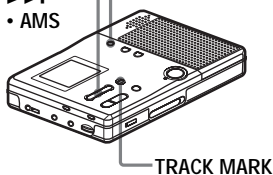

- 1 While playing the track you want to move, press MENU/ENTER.
- 2 Press ◀◀ or ▶▶ until “EDIT” appears in the display, and then press MENU/ENTER.
The recorder plays the selected track repeatedly.
- 3 Press ◀◀ or ▶▶ until “Move” appears in the display, and then press MENU/ENTER.
- 4 Press ◀◀ or ▶▶ until “ : Move” flashes in the display, and then press MENU/ENTER again.
The selected track number flashes in the display.

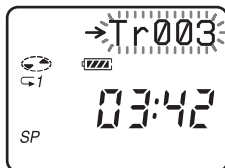

- 5 Press ◀◀ or ▶▶ to select the destination track number.
For the example, “Tr002” appears in the display.

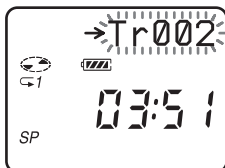

- 6 Press MENU/ENTER again.
The track moves to the selected destination track.

To cancel moving
Press ■ • STOP.

Erasing tracks (Erase)

You can erase unnecessary tracks or all tracks in a disc.

Note

When you erase groups, see page 37.

To erase a track

Note that once a recording has been erased, you cannot retrieve it. Be sure to verify the contents of the track you want to erase.

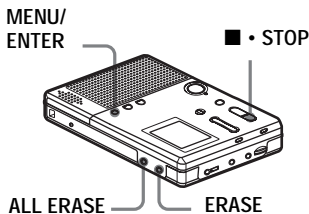

- 1 While playing the track you want to erase, press ERASE. "Erase OK?" and "PushENTER" appear alternately in the display.

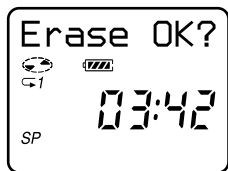

- 2 Press MENU/ENTER. The track is erased and the next track starts to play. All the tracks after the one erased are automatically renumbered.

To cancel erasing

Press ■ • STOP.

To erase a small section of a track

Pause playback at the point where you want to start erasing. Then do steps 1 and 2.

To erase a part of a track

Add track marks at the beginning and the end of the part you want to erase, then erase the part (page 29).

To erase the whole disc

Note that once a recording has been erased, you cannot retrieve it. Be sure to verify the contents of the disc you want to erase.

- 1 Play the disc you want to erase, verify its contents, and then press ■ • STOP.
- 2 While the recorder is stopped, press ERASE while pressing ALL ERASE. "All Erase?" and "PushENTER" appear alternately in the display.

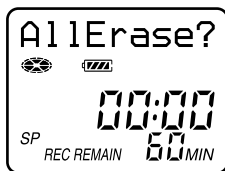

- 3 Press MENU/ENTER. "TOC Edit" flashes in the display, and all the tracks will be erased. When erasing is complete, "BLANKDISC" appears in the display.

To cancel erasing

Press ■ • STOP.

Using the group function

The group function is provided to allow playback of discs with group settings. The group function is convenient for playback of MDs on which several albums or CD singles have been recorded in MDLP (LP2/LP4) mode.

What is the disc with group settings?

The recorder can operate various functions in units of group; that is tracks that have been recorded on a disc as part of separate group, as shown below.

Before group assignments are made (normal play)

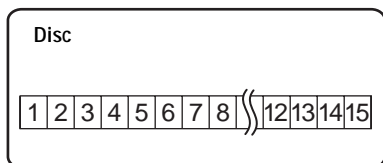

- ↓
- Track 1 to 5 are assigned to group 1.
 - Track 8 to 12 are assigned to group 2.
 - Track 13 to 15 are assigned to group 3.
 - Track 6 to 7 are assigned to no group.

After group assignments have been made (group play)

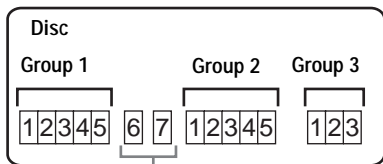

Tracks that were not assigned to a group are treated as being part of "Group - -".

You can create a maximum of 99 groups on a disc.

Note

It will not be possible to make a group setting if the tracks, groups and disc name on a disc exceed the maximum number that can be input.

Using the group function when recording

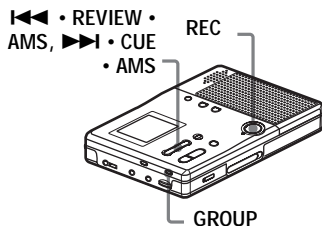

Recording tracks to a new group

During recording, you can add a new group at the end of the currently recorded tracks on a disc.

- 1 While pressing GROUP, press REC.
- 2 Play the source sound.
A new group will be added after the current contents on a disc.

To stop recording

Press ■ • STOP.

The material that was recorded up until ■ • STOP was pressed is entered as a new group.

Recording a track to an existing group

You can add a track to an existing group.

- 1 Press GROUP and press ◀◀ or ▶▶ until the group you want to add a track to appears in the display.
- 2 While pressing GROUP, press REC.
- 3 Play the source sound.



- To add a track that is playing to a group, stop or pause playing the track first, and then do the procedure from step 2.
- You can set the recorder to always create a new group without pressing the GROUP button. See page 39 for details.

Using the group function when playing

The recorder can operate various playback with a disc which has group setting.

In group mode, the recorder treats all tracks without group settings as belonging to the last group on the disc. The last group is indicated in the display window on the recorder as “Group --”. Within a group, the tracks appear in their order on the disc, not their order within the group.

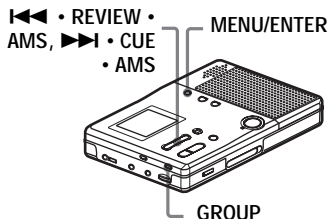

Playing a track in group play

Start playback from the top group to the end, and then stop after playback of the tracks which do not belong to a group (Group - -).

- 1 Do the procedure of “Selecting the play mode (Single Play/Repeat Play)” (page 27) and select “☐ : Normal” in step 3.
The group play starts from the next track.
- 2 Press ◀◀ or ▶▶ and select “RepeatOFF” or “RepeatON”, and then press MENU/ENTER to enter the selection.

Cueing to the groups (Group Skip)

- 1 While playing, press GROUP.
“☐” flashes in the display.
- 2 Press ◀◀ or ▶▶ to select a group.

Repeat play for the selected group (Group Repeat Play)
Select “RepeatON” in step 2.

Editing groups

Assigning tracks or groups as a new group (Group Setting)

With this function, you can assign existing tracks or groups to a new group, and also you can assign a track that currently belongs to no group to an existing group.

You can create a maximum of 99 groups on a disc.

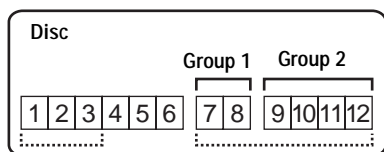

Assigning tracks 1 to 3 to a new group
Assigning group 1 and group 2 to a new group

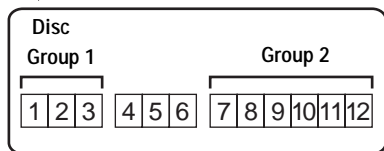

Registration of non-consecutive tracks is not possible (for example, track 3 and tracks 7 and 8 (Group 1) cannot be registered to a new group).

Track numbers appear according to their order on the disc, not their order within the group.

Notes

- It is not possible to make a group setting if the tracks, groups and disc name on a disc contain more than the maximum number of characters that can be stored.
- The tracks or groups must be sequential. If the desired tracks or groups are not consecutive, you must move them to make them consecutive before you can register them ("Moving recorded tracks (Move)", page 30).

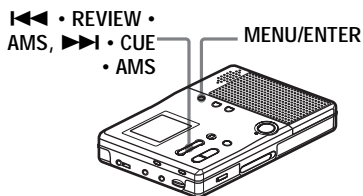

- 1 While the recorder is stopped, press MENU/ENTER.
- 2 Press ◀◀ or ▶▶ until "EDIT" appears in the display, and then press MENU/ENTER.
- 3 Press ◀◀ or ▶▶ until "☐: Set" appears in the display, and then press MENU/ENTER

The track number of the first track ("STR") appears in the display.

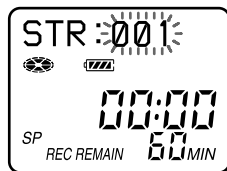

- 4 Press ◀◀ or ▶▶ until the number of the desired first track appears in the display, and then press MENU/ENTER.
- This selects the first track of the new group.

- 5 Press **◀◀** or **▶▶** until the number of the desired last track flashes in the display, and then press MENU/ENTER.

This selects the last track of the new group.
“**⏏**:” appears in the display and the group is set.

To cancel the procedure

Press **■** • STOP for 2 seconds or more.

To return the preceding setting

Press **■** • STOP.

Notes

- In step 4, the first track must be either the first track of an existing group or a track that does not belong to a group.
- When selecting the last track in step 5, make sure the track comes after the one selected in step 4. The last track must be either the last track of an existing group or a track that does not belong to a group.

To release a group setting

◀◀ • REVIEW • AMS, **▶▶** • CUE • AMS
MENU/ENTER
• AMS

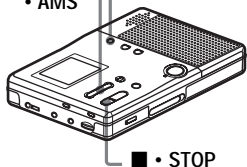

- 1 Select a group you want to release and check the contents (see “Playing a track in group play” (page 33)).
- 2 Press **■** • STOP.
- 3 Press MENU/ENTER.
- 4 Press **◀◀** or **▶▶** until “EDIT” appears in the display, and then press MENU/ENTER.

- 5 Press **◀◀** or **▶▶** until “**⏏**: Release” appears in the display, and press MENU/ENTER.
“Release?” and “PushENTER” appear in the display.

- 6 Press MENU/ENTER.
The group setting of the selected group is released.

To cancel the procedure

Press **■** • STOP for 2 seconds or more.

To return the preceding setting

Press **■** • STOP.

Moving a track in a disc with group setting

You can move a track from one group out of the group or to another group. You can also move a track that does not belong to a group to an existing group.

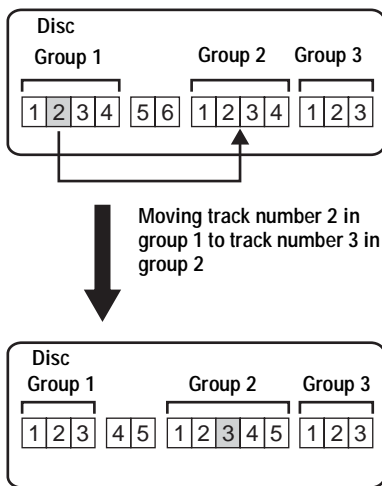

continued

◀◀ • REVIEW •
AMS, ▶▶ • CUE
• AMS

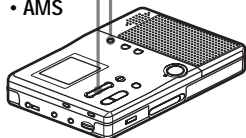

- 1 While playing the track you want to move, press MENU/ENTER.
- 2 Press ◀◀ or ▶▶ until “EDIT” appears in the display, and then press MENU/ENTER.

The recorder plays the selected track repeatedly.

- 3 Press ◀◀ or ▶▶ until “Move” appears in the display, and then press MENU/ENTER.
- 4 Press ◀◀ or ▶▶ until “♪ : Move” appears in the display, and then press MENU/ENTER.

- 5 When moving a track out of a group, skip this step.

When moving a track to a different group, press ◀◀ or ▶▶ until the destination group appears in the display, and then press MENU/ENTER.

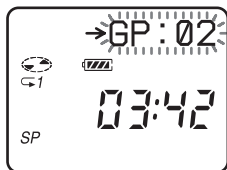

- 6 Press ◀◀ or ▶▶ until the destination track number (the track number within a group if the destination is a different group) appears in the display, and then press MENU/ENTER to enter your selection.

To cancel moving

Press ■ • STOP for 2 seconds or more.

To return the preceding setting

Press ■ • STOP.

Changing the order of a group on a disc (Group Move)

◀◀ • REVIEW •
AMS, ▶▶ • CUE
• AMS

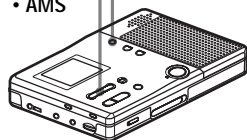

- 1 While playing a track within a group whose order you want to change, press MENU/ENTER.
- 2 Press ◀◀ or ▶▶ until “EDIT” appears in the display, and then press MENU/ENTER.
- 3 Press ◀◀ or ▶▶ until “Move” appears in the display, and then press MENU/ENTER.

- 4 Press **⏮** or **⏭** until “**📁**: Move” appears in the display, and then press MENU/ENTER.

The group number appears and the destination group number in a disc flashes in the display.

Currently selected
Group number Destination
group number

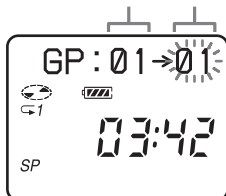

- 5 Press **⏮** or **⏭** to select the destination point on the disc, and then press MENU/ENTER.

To cancel moving

Press **■ • STOP** for 2 seconds or more.

To return the preceding setting

Press **■ • STOP**.

To erase a group

You can erase tracks in a selected group.

Note that once a recording has been erased, you cannot retrieve it. Be sure to check the contents of the group before you erase it.

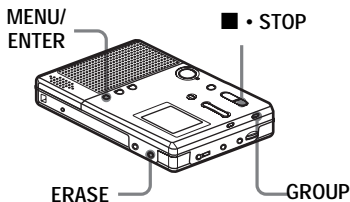

- 1 Select a group you want to erase and check the contents (see “Playing a track in group play” (page 33)).
- 2 Press **■ • STOP**.
- 3 Press ERASE while pressing GROUP.
“GP Erase?” and “PushENTER” appear alternately in the display.
- 4 Press MENU/ENTER to erase the group.

To cancel erasing

Press **■ • STOP**.

Useful settings

The recorder has many menus with useful functions for recording, playback, editing, etc. The following table shows the menu items that you can select.

Category	Function	What it does	Site page
Recording	Synchro-Recording	Simplifies operations during digital recording.	page 23
	Adding track marks (Divide)	You can add track marks manually or automatically (at 10-minute time interval).	page 24
	Selecting the microphone sensitivity	Sets the microphone sensitivity to suit the source sound.	page 39
	Group recording	Sets the recorder to create a new group with each recording operation.	page 39
Playing	Changing the sound quality	Selects to the desired sound mode.	page 26
	Selecting the play mode	Selects the play mode, such as repeat play, program play, etc.	page 27
	Starting an operation quickly	Sets the recorder to quickly start playback or cue to a track, or to quickly write data after a recording operation is stopped.	page 40
Editing	Moving	Changes the order of tracks or groups.	page 30 (track) page 35 (group)
	Assigning tracks to groups	Assigns recorded tracks or groups to a new group.	page 34
	Releasing a group	Releases group settings.	page 35
General	Setting for using a foot control unit	Sets the recorder for use with the optional foot control unit.	page 40

How to use the menu items

To set the menu items, do the following procedure.

- 1 Press MENU/ENTER to enter the menu
- 2 Press ◀◀ or ▶▶ to select the item.
- 3 Press MENU/ENTER to enter the selection.
- 4 Repeat steps 2 and 3.

To return the preceding setting

Press ■ • STOP.

To cancel the operation while setting

Press ■ • STOP for 2 seconds or more.

◀◀ • REVIEW •
AMS, ▶▶ • CUE
• AMS

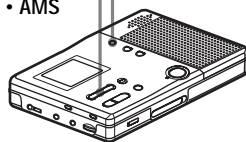

Creating a new group when recording

By pressing REC, you can set the recorder to create a new group automatically each time you record. This is convenient when recording several CDs in succession.

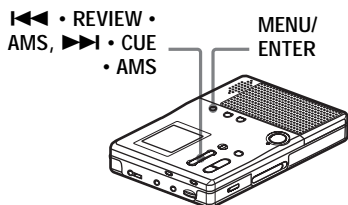

- 1 While the recorder is stopped, enter the menu and select "REC SET" - "☐ : REC".
- 2 Select "☐ : REC ON".

To turn the setting to normal
Select "☐ : REC OFF"

To select microphone sensitivity

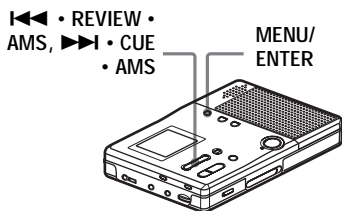

- 1 Enter the menu and select "REC SET" - "MIC SENS".
- 2 Select "SENS HIGH" or "SENS LOW".

SENS HIGH (factory setting): Use this setting when recording soft or normal volume sounds (such as conversations).

SENS LOW: Use this setting when recording loud sounds or sound at close range (such as a narration or a music concert, etc.)

Starting an operation quickly (Quick Mode)

Playback starts quickly after pushing the playback button or cueing to a track, or an internal recorder operation starts quickly (such as writing data after stopping a recording operation).

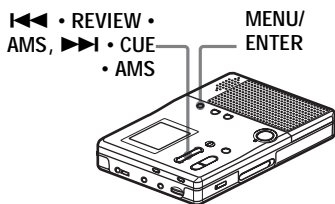

- 1 Enter the menu and select "OPTION" - "PowerMode".
- 2 Select "QUICK".

To switch back to the normal setting

Select "NORMAL".

Notes

- When the power mode is set to "QUICK", the power remains on within the recorder even when nothing appears in the display. This leads to a shorter battery life. The shortened battery life for each recording mode is as follows:

Recording mode	Approx. battery life (when recording)
SP	15 hours
LP2	17 hours
LP4	18 hours
Monaural	17 hours

- If no recorder operation (including opening or closing of the lid) occurs for one hour, the recorder turns off. For this reason, the next time you start playback or do another operation, the recorder will not respond quickly. The unit, however, will return to quick mode afterwards.

Using an optional foot control unit

If you use the optional foot control unit (FS-85B50), you can use your foot to pause or restart recording or start or pause playback. If you use the foot control unit, set the recorder for foot control use.

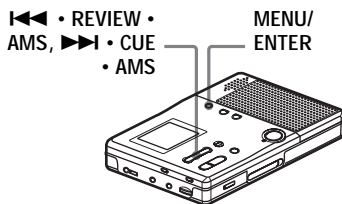

- 1 Enter the menu and select "OPTION" - "FOOT SW".
- 2 Select "SW ON".

Notes









- The recorder is factory set to "SW ON".
- If you connect an optional remote control with a display window, the "FOOT SW" setting will automatically change to "SW OFF". If you attach the foot control unit afterwards, you must change the setting from "FOOT SW" back to "SW ON".

List of menus

Items listed under “Menu 1” are the selectable items which appear when you press the jog dial, items listed under “Menu 2” are the selectable items which appear when you select an item in Menu 1, and “Menu 3” are the selectable items which appear when you select an item in Menu 2.

Note

Different indication may be displayed depending on the operating conditions and disc settings.

Menu 1	Menu 2	Menu 3
EDIT	 : Set	—
	 : Release	—
	Move	 : Move ↔  : Move
PLAY MODE	Normal	RepeatOFF (factory setting) ↔ RepeatON
	1 Track	
	 : Normal	
SOUND	SOUND OFF	—
	SOUND 1	—
	SOUND 2	—
REC SET	TIME MARK	MARK OFF (factory setting) ↔ MARK ON
	MIC SENS	SENS HIGH (factory setting) ↔ SENS LOW
	 : REC	 : REC OFF (factory setting) ↔  : REC ON
	SYNC REC	SYNC OFF (factory setting) ↔ SYNC ON
OPTION	PowerMode	NORMAL (factory setting) ↔ QUICK
	FOOT SW	SW ON (factory setting) ↔ SW OFF

You can power the recorder not only with alkaline dry battery but also with house current. You cannot, however, use manganese dry battery.

When to replace the batteries

You can check the battery condition with the battery indication which is displayed while using the recorder. The battery indicator changes due to the battery condition.

The battery level indicator is approximate.

Battery indicator



Batteries power decreasing



Weak batteries



The batteries has gone out. "LOW BATT" flashes in the display on the recorder, and the power goes off.

Battery life

The battery life may be shorter due to operating conditions and the temperature of the location.

When recording¹⁾²⁾

(Unit: approx.hours)(JEITA³⁾)

Recording mode	Approx. hours
SP	24
LP2	34
LP4	48
MONO	34

¹⁾ When using a Sony LR6 (SG) "STAMINA" alkaline dry batteries (produced in Japan) and "PowerMode" is set to "NORMAL" (page 40). Setting "PowerMode" to "QUICK" result in a shorter battery life (page 40).

²⁾ When recorded with the built-in microphone.

³⁾ Measured in accordance with the JEITA (Japan Electronics and Information Technology Industries Association) standard.

When playing¹⁾

(Unit: approx.hours)(JEITA²⁾)

Recording mode	Speaker ³⁾	Headphones/earphones ⁴⁾
SP	45	90
LP2	50	100
LP4	55	110
MONO	50	100

¹⁾ When using a Sony LR6 (SG) "STAMINA" alkaline dry batteries (produced in Japan) and "PowerMode" is set to "NORMAL" (page 40).

²⁾ Measured in accordance with the JEITA (Japan Electronics and Information Technology Industries Association) standard.

³⁾ When played using the built-in speaker.

⁴⁾ When played using headphones/earphones.

Notes

- Stop the recorder before replacing batteries.
- An optional AC power adaptor is recommended for long recording.

Using house current

- 1 Attach the supplied clamp filter to the optional AC power adaptor (see page 8).
- 2 Connect the AC power adaptor to DC IN 3V.
- 3 Connect the AC power adaptor to the wall outlet.

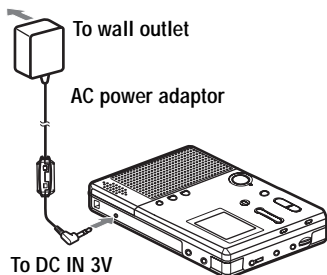

Notes

- For use in your house: Use the AC power adaptor (not supplied). Do not use an AC power adaptor other than the recommended one since it may cause the recorder to malfunction.

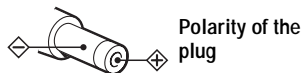

- There are regional differences in AC-E30HG specifications. For this reason, you should verify that the power requirements and plug configuration are appropriate for your area before you purchase the recorder.
- Connect the AC power adaptor to an easily accessible AC outlet. Should you notice an abnormality in the AC power adaptor, disconnect it from the AC outlet immediately.

Precautions

On safety

Do not put any foreign objects in the DC IN 3V jack.

On power sources

- Use LR6 (size AA) batteries, house current, or car battery.
- The recorder is not disconnected from the AC power source (mains) as long as it is connected to the wall outlet, even if the recorder itself has been turned off.
- If you are not going to use this recorder for a long time, be sure to disconnect the power supply (an optional AC power adaptor, dry batteries, or car battery cord). To remove the AC power adaptor (not supplied) from the wall outlet, grasp the adaptor plug itself; never pull the cord.

On heat build-up

Heat may build up in the recorder if it is used for an extended period of time. In this case, leave the recorder turned off until it cools down.

On installation

- Never use the recorder where it will be subjected to extremes of light, temperature, moisture or vibration.
- Never wrap the recorder in anything when it is being used with the AC power adaptor (not supplied). Heat build-up in the recorder may cause malfunction or damage.
- Never carry the recorder together with a hard object within the supplied carrying pouch. Friction with the object may cause flaking or scratching on the recorder's painted surface.

On the headphones/earphones

Road safety

Do not use the headphones/earphones while driving, cycling, or operating any motorized vehicle. It may create a traffic hazard and is illegal in many areas. It can also be potentially dangerous to play your recorder at high volume while walking, especially at pedestrian crossings. You should exercise extreme caution or discontinue use in potentially hazardous situations.

Preventing hearing damage

Avoid using the headphones/earphones at high volume. Hearing experts advise against continuous, loud and extended play. If you experience a ringing in your ears, reduce the volume or discontinue use.

Caring for others

Keep the volume at a moderate level. This will allow you to hear outside sounds and to be considerate of the people around you.

On the MiniDisc cartridge

- When carrying or storing the MiniDisc, keep it in its case.
- Do not break open the shutter.
- Do not place the cartridge where it will be subject to light, extreme temperatures, moisture or dust.
- Attach the supplied MD label only in the space designated for it on the disc. Do not stick it on any other disc surface.

Notes on batteries

Incorrect battery usage may lead to leakage of battery fluid or bursting batteries. To prevent such accidents, observe the following precautions:

- Insert the + and – poles of the batteries correctly.
- Do not try to recharge dry batteries.
- When the recorder is not to be used for a long time, be sure to remove the batteries.
- If a battery leak should develop, carefully and thoroughly wipe away battery fluid from the battery compartment before inserting new ones.

Note on mechanical noise

The recorder gives off mechanical noise while operating, which is caused by the power-saving system of the recorder and it is not a problem.

On cleaning

- Clean the recorder casing with a soft cloth slightly moistened with water or a mild detergent solution. Do not use any type of abrasive pad, scouring powder or solvent such as alcohol or benzene as it may mar the finish of the casing.
- Wipe the disc cartridge with a dry cloth to remove dirt.
- Dust on the lens may prevent the unit from operating properly. Be sure to close the disc compartment lid after inserting or ejecting an MD.
- To obtain the best sound quality, use a dry cloth to wipe the plug of the headphones/earphones. Dirty plug may cause sound distortion or intermittent breaks in the sound.

Note on maintenance

Clean the terminals periodically with a cotton swab or a soft cloth as illustrated.

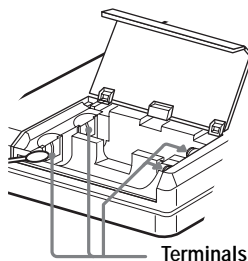

On the battery compartment lid

The battery compartment lid is designed to detach from the recorder when it is handled with great force. Do the following steps to reattach the lid.

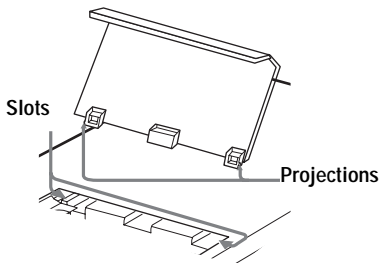

- 1 Insert the projections on the PUSH OPEN tab firmly into the slots on the recorder one at a time.

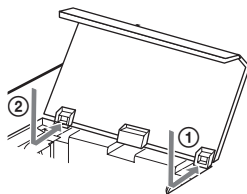

- 2 Insert the projections on the lid firmly into the slots on the PUSH OPEN tab one at a time.

To protect a recorded MD

To record-protect an MD, slide open the tab at the side of the MD. In this position, the MD cannot be recorded. To record again, slide the tab back so the tab is visible.

When the disc is record-protected

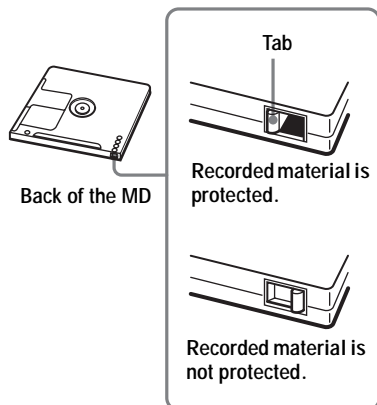

If you have any questions or problems concerning your recorder, please consult your nearest Sony dealer. (If a trouble occurred when the disc was in the recorder, we recommend that the disc be left in the recorder when you consult your Sony dealer so that the cause of trouble may be better understood.)

Specifications

System

Audio playing system

MiniDisc digital audio system

Laser diode properties

Material: GaAlAs

Wavelength: $\lambda = 790$ nm

Emission duration: continuous

Laser output: less than 44.6 μ W

(This output is the value measured at a distance of 200 mm from the lens surface on the optical pick-up block with 7 mm aperture.)

Recording and playback time

When using MDW-80

Maximum 160 min. in monaural.

Maximum 320 min. in LP4 stereo

Revolutions

350 rpm to 2,800 rpm (CLV)

Error correction

ACIRC (Advanced Cross Interleave Reed

Solomon Code)

Sampling frequency

44.1 kHz

Sampling rate converter

Input: 32 kHz/44.1 kHz/48 kHz

Coding

ATRAC (Adaptive TRansform Acoustic

Coding)

ATRAC3 — LP2/LP4

Modulation system

EFM (Eight to Fourteen Modulation)

Speakers (two units)

28 mm (1¹/₈ in.) dia. per unit

Frequency response (digital/analog input)

20 to 20,000 Hz \pm 3 dB

Inputs

Microphone: stereo mini-jack
(minimum input level 0.25 mV)

Line in¹⁾:

stereo mini-jack for analog input
(minimum input level 39 mV)

optical (digital) mini-jack for optical
(digital) input

Outputs

: stereo mini-jack (dedicated remote control jack)

Maximum output (DC)²⁾

Headphones/earphones: 5 mW + 5 mW (16 Ω)

Speakers (monaural): 140 mW (70 mW \times 2)

General

Power requirements

AC power adaptor DC 3V

LR6 (size AA) alkaline dry battery

Battery operation time

See "Battery life" (page 42)

Dimensions²⁾

Approx. 117.2 \times 23.0 \times 74.4 mm (w/h/d)
(4⁵/₈ \times 2⁹/₃₂ \times 3 in.) not incl. projecting parts
and controls.

Mass

Approx. 150 g (5.3 oz) (main unit only)

¹⁾ The LINE IN (OPTICAL) jack is used to connect either a digital (optical) cable or a line (analog) cable.

²⁾ Measured in accordance with JEITA.

Optional accessories

AC power adaptor AC-E30HG

Optical Cable POC-15B, POC-15AB

Line Cable RK-G129, RK-G136

Stereo Microphones ECM-719

Recordable MDs MDW-series

Foot control unit FS-85B50

MDR series stereo headphones/earphones*

* When using optional headphones/earphones, use only headphones/earphones with stereo mini plugs. You cannot use headphones/earphones with micro plugs.

Your dealer may not handle some of the above listed accessories. Please ask the dealer for detailed information about the accessories in your country.

US and foreign patents licensed from Dolby Laboratories.

Design and specifications are subject to change without notice.

Troubleshooting

If a problem occurs during recorder operation, follow the steps described below before consulting the nearest Sony dealer. If any messages appear, it is recommended to take notes.





- 1 Check to see if the problem is listed in, “Troubleshooting” (page 48).
Check “Messages” (page 53) for the problem as well.
- 2 If after step 1 you still cannot solve the problem, consult your nearest Sony dealer.

While recording

Symptom	Cause/Remedy
Recording cannot be done correctly.	<ul style="list-style-type: none">• Audio sources may not be securely connected. ➔ Disconnect the audio sources once and connect them again (pages 21, 22).• There is no digital signal from the portable CD player. ➔ When recording digitally from a portable CD player, use the AC power adaptor and disable the anti-skip function (such as ESP) on the CD player (page 21).• The analog recording was made using a connecting cord with an attenuator. ➔ Use a connecting cord without an attenuator (page 22).• The power sources was disconnected or a power outage occurred during recording. ➔ The recording result is not recorded on the disc. Make recording again.• The premastered MD is inserted. ➔ Replace to the recordable MD.• The remaining recordable time on the disc is 12 seconds or less (“DISC FULL” appears). ➔ Replace the disc.
Momentary noise is heard when recording.	<ul style="list-style-type: none">• Due to the special digital audio compression technology used in LP4 stereo mode, momentary noise may occur on very rare occasions with certain sound sources. ➔ Record in SP or LP2 mode (page 18).
The lid does not open after recording.	<ul style="list-style-type: none">• The lid does not open until “TOC Edit” disappears in the display.

Symptom	Cause/Remedy
<p>“TR FULL” appears even before the disc has reached the maximum recording time (60, 74, or 80 minutes) and the recording cannot be done.</p>	<ul style="list-style-type: none"> • This is due to the MiniDisc system limitation. When 254 tracks have been recorded on the disc, “TR FULL” appears regardless of the total recorded time. More than 254 tracks cannot be recorded on the disc. ➔ To continue recording, erase unnecessary tracks.
<p>The remaining recording time does not increase even after erasing numerous short tracks.</p>	<ul style="list-style-type: none"> • This is due to the MiniDisc system limitation. Tracks of under 12 seconds, 24 seconds, 48 seconds in length are not counted and so erasing them may not lead to an increase in the recording time.
<p>The total recorded time and the remaining time on the disc may not total the maximum recording time (60, 74, or 80 minutes).</p>	<ul style="list-style-type: none"> • This is due to the MiniDisc system limitation. Normally, recording is done in minimum units of approximately 2 seconds (in stereo), 4 seconds (in LP2 stereo mode or monaural mode), or 8 seconds (in LP4 stereo mode). When recording is stopped, the last unit of recording always uses this unit of 2 seconds, 4 seconds, or 8 seconds even if the actual recording is shorter. Likewise, when recording is restarted after the stop, the recorder will automatically insert a blank space amounting to 2 seconds, 4 seconds, or 8 seconds before the next recording. (This is to prevent accidental erasing of a previous track whenever a new recording is started). Therefore, the actual recording time will decrease whenever a recording is stopped; a maximum of 6 seconds, 12 seconds, or 24 seconds compared to the potential recording time for each stop.
<p>“TR FULL” appears even before the disc has reached the maximum track number or recording time.</p>	<ul style="list-style-type: none"> • This is due to the MiniDisc system limitation. Repeated recording and erasing may cause fragmentation and scattering of data. Although those scattered data can be read, each fragment is counted as a track. In this case, the number of tracks may reach 254 and further recording is not possible. To continue recording, erase unnecessary tracks. ➔ To continue recording, erase unnecessary tracks.

While playing

Symptom	Cause/Remedy
An MD is not played normally.	<ul style="list-style-type: none"> • Repeat play is selected. ➔ Change back to the normal play (page 27). • Playback mode is changed. ➔ Change back to the normal play (page 27).
An MD is not played from the first track.	<ul style="list-style-type: none"> • Disc playing stopped before it came to the last track. ➔ Press ► • PLAY for 2 seconds or more to start playing.
Playback sound skips.	<ul style="list-style-type: none"> • The recorder is placed where it receives continuous vibration. ➔ Put the recorder on a stable place. • A very short track may cause sound to skip. ➔ Try not to create a track under one second long.
Sound has a lot of static.	<ul style="list-style-type: none"> • Strong magnetism from a television or such device is interfering with operation. ➔ Move the recorder away from the source of strong magnetism.
The volume of the recorded track is low.	<ul style="list-style-type: none"> • The track was recorded in analog mode (in digital mode, the recording level is automatically set to the same level as that of the sound source). Or you used a connecting cord with an attenuator (such as an optional RK-G128, RK-G134, etc.) . ➔ Use a correct connecting cord (such as RK-G129, RK-G136, etc.).
No sound comes through the headphones/earphones.	<ul style="list-style-type: none"> • The headphones/earphones plug is not firmly connected. ➔ Plug in the plug of the headphones/earphones firmly to the  jack. • The plug is dirty. ➔ Clean the plug.
The recorder skips several tracks ahead or behind whenever you press the  • REVIEW • AMS or  • CUE • AMS button.	<ul style="list-style-type: none"> • The GROUP button has been pressed and  is flashing in the display. ➔ The recorder returns to normal if no operation is made for 5 seconds.
The edited tracks may exhibit sound dropout during search operations.	<ul style="list-style-type: none"> • This occurs due to the MiniDisc system limitation. The fragmentation of data may cause sound dropout while searching because the tracks are played in higher speed than normal playback.

Symptom	Cause/Remedy
There is no R-channel sound output when playing a track recorded from a cassette deck or through an amplifier, or when listening to sound from a cassette deck or amplifier.	<ul style="list-style-type: none"> • There is no R-channel output if the cassette deck or an amplifier is connected with a monaural cord. <ul style="list-style-type: none"> ➔ Make sure to use a stereo connecting cord. If, however, the connected equipment is monaural, there will be no R-channel sound output even with a stereo connecting cord.
The optional foot control unit does not work properly.	<ul style="list-style-type: none"> • The recorder is not set for foot control unit use. <ul style="list-style-type: none"> ➔ Set "FOOT SW" in the menu to "SW ON" (page 40).

While Editing

Symptom	Cause/Remedy
The lid does not open.	<ul style="list-style-type: none"> • The power sources have been disconnected during recording or editing, or the battery have been exhausted. <ul style="list-style-type: none"> ➔ Set the power sources again, or replace the exhausted battery with new ones.
Editing cannot be done.	<ul style="list-style-type: none"> • The power source has been disconnected or a power outage has occurred during editing. <ul style="list-style-type: none"> ➔ The editing done to that point is not saved to the disc. Do the editing operation again.
Track marks cannot be erased.	<ul style="list-style-type: none"> • This is due to the MiniDisc system limitations. When the data of a track is fragmented, the track mark of a fragment under 12 seconds long (recorded in stereo), 24 seconds long (recorded in LP2 stereo mode or monaural mode), or 48 seconds long (recorded in LP4 stereo mode) cannot be erased. You cannot combine a track recorded in stereo and a track recorded in monaural; nor can you combine a track recorded with digital connection and a track recorded with analog connection.
The disc cannot edit on other component.	<ul style="list-style-type: none"> • The component does not support MDLP. <ul style="list-style-type: none"> ➔ Edit on other component that support MDLP.

While using group function

Symptom	Cause/Remedy
The group function does not operate.	<ul style="list-style-type: none">• While using a disc without group setting, an attempt was made to select some group-related menu. ➔ Use a disc with group setting.
A track cannot be recorded to a new group. A new group cannot be created.	<ul style="list-style-type: none">• This is due to the MiniDisc system limitations. If the total number of characters for the disc can store exceeds approximately 1,700, a new group cannot be created even though group mode is on. It is also impossible to make group settings at this time.

Others



Symptom	Cause/Remedy
The display window is not normal.	<ul style="list-style-type: none">• The recorder was disconnected from the power source. ➔ Let the recorder sit for a while, or disconnect the power source, reconnect it, and then press any of the operation buttons.
The recorder does not work or works poorly.	<ul style="list-style-type: none">• The volume is low. ➔ Turn up the volume.• No disc is inserted. ➔ Insert a recorded disc.• The HOLD function is turned on (“HOLD” appears in the display when you press an operation button on the recorder). ➔ On the recorder, disable HOLD by sliding the HOLD switch to the opposite direction of the arrow.• The lid is not firmly closed. ➔ Close the lid until it clicks.• Moisture has condensed inside the recorder. ➔ Take the MD out and leave the recorder in a warm place for several hours until the moisture evaporates.• The dry batteries are weak (“LOW BATT” flashes or nothing appears). ➔ Replace the dry batteries with the new one (page 12), or connect the AC power adaptor to the recorder.• The dry battery have been inserted incorrectly. ➔ Insert the battery correctly (page 12).• The disc is damaged or does not contain proper recording or editing data. ➔ Reinsert the disc. Rerecord the disc. If the error message still appears, replace it with another disc.• A disc with no track is inserted. ➔ Replace to another disc.



The recorder does not work or works poorly.	<ul style="list-style-type: none"> • The record protect tab is opened. <ul style="list-style-type: none"> ➔ Slide the record protect tab closed (page 46). • While operating, the recorder received a mechanical shock, too much static, abnormal power voltage caused by lightning, etc. <ul style="list-style-type: none"> ➔ Restart the operation as follows. <ol style="list-style-type: none"> 1 Take out batteries or disconnect all the power sources. 2 Leave the recorder for about 30 seconds. 3 Insert batteries or connect the power source.
---	--

Messages

If the following messages flash in the display window, check the chart below.

Error message	Meaning/Remedy
BLANKDISC	<ul style="list-style-type: none"> • An MD with no recording on it is inserted. <ul style="list-style-type: none"> ➔ Insert a recorded MD.
BUSY	<ul style="list-style-type: none"> • You tried to operate the recorder while it was accessing the recorded data. <ul style="list-style-type: none"> ➔ Wait until the message goes out (in rare cases, it may take 2–3 minutes).
DISC FULL	<ul style="list-style-type: none"> • The remaining recording time on the disc is 12 seconds (SP), 24 seconds (LP2 or monaural), 36 seconds (LP4), or less. <ul style="list-style-type: none"> ➔ Replace the disc.
ERROR	<ul style="list-style-type: none"> • There is an internal malfunction in the system. <ul style="list-style-type: none"> ➔ Restart the operation by doing steps 1 to 3 on page 53. If the message appears again, please consult your nearest Sony dealer.
GroupFULL	<ul style="list-style-type: none"> • You tried to create a 100th group. <ul style="list-style-type: none"> ➔ You can create only up to 99 groups on a disc. Keep the group number within 99.
Hi DC in	<ul style="list-style-type: none"> • Voltage of the power supply is too high (The recommended AC power adaptor or the recommended car battery cord is not used). <ul style="list-style-type: none"> ➔ Use the recommended AC power adaptor (not supplied) or the car battery cord (not supplied).
HOLD	<ul style="list-style-type: none"> • The recorder is locked. <ul style="list-style-type: none"> ➔ Slide HOLD against the arrow to unlock the recorder.
LOW BATT	<ul style="list-style-type: none"> • Batteries are weak. <ul style="list-style-type: none"> ➔ Replace the dry batteries (page 12).
MEM OVER	<ul style="list-style-type: none"> • You tried to record with the recorder placed where it receives continuous vibration. <ul style="list-style-type: none"> ➔ Put the recorder on a stable place, and start recording again.

Error message	Meaning/Remedy
NO COPY	<ul style="list-style-type: none"> • You tried to make a copy from a disc that is protected by the Serial Copy Management System. You cannot make copies from a digitally connected source which was itself recorded using digital connection. ➔ Use analog connection instead (page 22).
NO DISC	<ul style="list-style-type: none"> • You tried to play or record with no disc in the recorder. ➔ Insert an MD.
NO EDIT	<ul style="list-style-type: none"> • You tried to erase a group with a disc without group setting. ➔ You cannot erase groups with a disc with no groups. • You selected “ : Set”, “ : Release”, or “Move” while recording. • You tried to erase a track, disc, or group while recording. • You tried to erase a track mark to combine tracks the recorder cannot combine (a track recorded in stereo and in mono, for example). • You tried to overwrite a track marks.
NO SET	<ul style="list-style-type: none"> • You tried to make the following settings while recording. — Recording mode — Selection of “ : REC” in menu — Play mode while “End” appears in the display
NoOPERATE	<ul style="list-style-type: none"> • You tried to make the Auto Time Mark setting while recording through digital connection. • You tried to press • PAUSE or TRACK MARK during synchro-recording.
NO SIGNAL	<ul style="list-style-type: none"> • The recorder could not detect digital input signals. ➔ Make sure that the source is connected firmly (page 21).
P/B ONLY	<ul style="list-style-type: none"> • You tried to record or edit on a premastered MD (P/B stands for “playback”). ➔ Insert a recordable MD.
PROTECTED	<ul style="list-style-type: none"> • You tried to record or edit on a MD with the tab in the record-protect position (page 46). ➔ Slide the tab back.
READ ERR	<ul style="list-style-type: none"> • The recorder cannot read the disc information correctly. ➔ Reinsert the disc.
REC ERR	<ul style="list-style-type: none"> • Recording was not correctly done. ➔ Place the recorder at a place with no vibrations and record again. • The disc is soiled with an oil film or finger prints, is scratched, or is not a standard disc. ➔ Try recording again with another disc.

Error message	Meaning/Remedy
SEL Group	<ul style="list-style-type: none"> • You selected “ : Move” or you tried to erase a group while the recorder is selecting a track that does not belong to a group. ➔ Select a track within a group you want to edit, and then do the editing operation again.
SEL Track	<ul style="list-style-type: none"> • You selected “ : Move” or you tried to erase a track after playback has already finished. ➔ Do the editing operation again after selecting the desired track first.
TEMP OVER	<ul style="list-style-type: none"> • Heat has built up in the recorder. ➔ Let the recorder cool down.
TOC Edit	<ul style="list-style-type: none"> • The MD player is recording information (track start and end position) from the memory to the disk. ➔ Wait until this process is completed. Do not expose the recorder to physical shock, nor disrupt power supply.
TOC ERR	<ul style="list-style-type: none"> • The recorder cannot read the disc information correctly. ➔ Insert another disc. ➔ If it is no problem to erase the entire disc, do so (page 31).
TR FULL	<ul style="list-style-type: none"> • There is no more space for new data when you are editing the MD. ➔ Erase unnecessary tracks (page 31).
TrPROTECT	<ul style="list-style-type: none"> • You tried to record or edit a write-protected track that was recorded on other device. ➔ Record or edit on other tracks.

Explanations

About the DSP TYPE-S for ATRAC/ATRAC3

This recorder supports DSP TYPE-S, a specification for high-level Sony MiniDisc decks equipped with digital signal processors (DSP). This specification allows the recorder to produce high-quality sound from tracks recorded in MDLP mode. Since it retains DSP TYPE-R support, the recorder produces superior results during recording or playback in SP (normal stereo) mode.

How the MiniDisc got so small

The 2.5-inch MiniDisc, encased in a plastic cartridge that looks like a 3.5-inch diskette (see illustration on the left column), uses a new digital audio compression technology called ATRAC (Adaptive TRansform Acoustic Coding). To store more sound in less space, ATRAC extracts and encodes only those frequency components actually audible to the human ear.

The meaning of “no sound”

“No sound” describes a recorder condition in which the input level is about 4.8 mV during analog input or less than -89 dB during optical (digital) input (with 0 dB as full bit (the maximum recordable level for a MiniDisc)).

Quick Random Access

Like CDs, MDs offer instantaneous random access to the beginning of any music track. Premastered MDs are recorded with location addresses corresponding to each music selection. Recordable MDs are manufactured with a “User TOC Area” to contain the order of the music. The TOC (Table of Contents) system is similar to the “directory management system” of floppy disks. In other words, starting and ending addresses for all music tracks recorded on the disc are stored in this area. This lets you randomly access the beginning of any track as soon as you enter the track number (AMS), as well as label the location with a track name as you would file on a diskette.

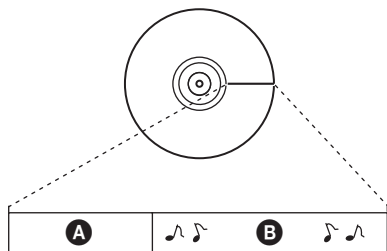

- A** — User TOC area
Contains the order and start/end points of the music.
- B** — Music Data

Shock-Resistant Memory

One major drawback of optical read systems is that they can skip or mute when subjected to vibration. The MD system resolves this problem by using a buffer memory that stores audio data.

Note on digital recording

This recorder uses the Serial Copy Management System, which allows only first-generation digital copies to be made from a home-recorded MD by using the analog (line out) connections.

Premastered software such as CDs or MDs.

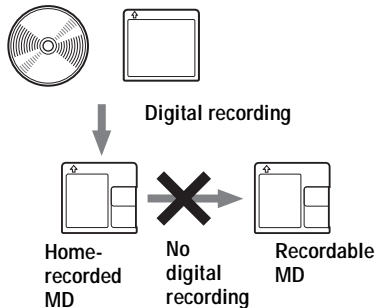

Microphone, record player, tuner, etc (with analog output jacks).

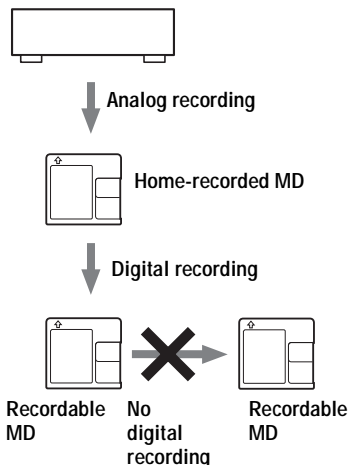

If you have any questions or problems concerning your recorder, please consult your nearest Sony dealer. (If a trouble occurred when the disc was in the recorder, we recommend that the disc be left in the recorder when you consult your Sony dealer so that the cause of trouble may be better understood.)

This warranty is valid only in the United States.

SONY

Tape Cassette Player/Recorder/CD Player/Mini Disc
DAT/Radio/Head Phone/Speaker/MIC/Personals

LIMITED WARRANTY

Portable Audio

Sony Electronics Inc. ("Sony") warrants this Product (including any accessories) against defects in material or workmanship as follows:

1. **LABOR:** For a period of 90 days from the date of purchase, if this Product is determined to be defective, Sony will repair or replace the Product, at its option, at no charge, or pay the labor charges to any Sony authorized service facility. After the Warranty Period, you must pay for **all** labor charges.

2. **PARTS:** In addition, Sony will supply, at no charge, new or rebuilt replacements in exchange for defective parts for a period of one (1) year. After 90 days from the date of purchase, labor for removal and installation is available from Sony authorized service facilities or a Sony Service Center at your expense.

To obtain warranty service, you must take the Product, or deliver the Product freight prepaid, in either its original packaging or packaging affording an equal degree of protection, to any authorized Sony service facility.

This warranty does not cover customer instruction, installation, set up adjustments or signal reception problems.

This warranty does not cover cosmetic damage or damage due to acts of God, accident, misuse, abuse, negligence, commercial use, or modification of, or to any part of the Product, including the antenna. This warranty does not cover damage due to improper operation or maintenance, connection to improper voltage supply, or attempted repair by anyone other than a facility authorized by Sony to service the Product. This warranty does not cover Products sold AS IS or WITH ALL FAULTS, or consumables (such as fuses or batteries). This warranty is valid only in the United States.

Proof of purchase in the form of a bill of sale or receipted invoice which is evidence that the unit is within the Warranty period must be presented to obtain warranty service.

This warranty is invalid if the factory applied serial number has been altered or removed from the Product.

REPAIR OR REPLACEMENT AS PROVIDED UNDER THIS WARRANTY IS THE EXCLUSIVE REMEDY OF THE CONSUMER. SONY SHALL NOT BE LIABLE FOR ANY INCIDENTAL OR CONSEQUENTIAL DAMAGES FOR BREACH OF ANY EXPRESS OR IMPLIED WARRANTY ON THIS PRODUCT. EXCEPT TO THE EXTENT PROHIBITED BY APPLICABLE LAW, ANY IMPLIED WARRANTY OF MERCHANTABILITY OR FITNESS FOR A PARTICULAR PURPOSE ON THIS PRODUCT IS LIMITED IN DURATION TO THE DURATION OF THIS WARRANTY.

Some states do not allow the exclusion or limitation of incidental or consequential damages, or allow limitations on how long an implied warranty lasts, so the above limitations or exclusions may not apply to you. In addition, if you enter into a service contract with the Sony Partnership within 90 days of the date of sale, the limitation on how long an implied warranty lasts does not apply to you. This warranty gives you specific legal rights, and you may have other rights which vary from state to state.

For your convenience, Sony Electronics Inc. has established telephone numbers for frequently asked questions:

To locate the servicer or dealer nearest you, or for service assistance or resolution of a service problem, or for product information or operation, call:

Sony Direct Response Center

1-(800)-222-7669

or write to:

Sony Direct Response Center

12451 Gateway Blvd.

Fort Myers, FL 33913

For an accessory or part not available from your authorized dealer, call:

1-(800)-488-SONY (7669)

D 455714701

<http://www.sony.net/>

Printed in Malaysia



Printed using VOC (Volatile Organic Compound)-free vegetable oil ink.