

MZ-S1

SERVICE MANUAL

Ver 1.0 2002.02

US Model
Canadian Model
AEP Model
UK Model



US and foreign patents licensed from Dolby Laboratories.

- OpenMG, "MagicGate", "MagicGate Memory Stick", "Memory Stick", VAIO, MusicClip and their logos are trademarks of Sony Corporation.
- "WALKMAN" is a trademark of Sony Corporation.
- Microsoft, Windows, Windows NT and Windows Media are trademarks or registered trademarks of Microsoft Corporation in the United States and/or other countries.
- IBM and PC/AT are registered trademarks of International Business Machines Corporation.
- Macintosh is a trademark of Apple Computer, Inc. in the United States and/or other countries.
- All other trademarks are trademarks of their respective owners. TM and [®] marks are omitted in this manual.

Model Name Using Similar Mechanism	MZ-N707
Mechanism Type	MT-MZN707-177
Optical Pick-up Name	LCX-5R

SPECIFICATIONS

MD Recorder

Audio playing system

MiniDisc digital audio system

Laser diode properties

Material: GaAlAs MQW

Wavelength: $\lambda = 790 \text{ nm}$

Emission duration: continuous

Laser output: less than $44.6 \mu\text{W}$

(This output is the value measured at a distance of 200 mm from the lens surface on the optical pick-up block with 7 mm aperture.)

Recording and playback time

When using MDW-80

Maximum 160 min. in monaural

Maximum 320 min. in stereo

Revolutions

Approx. 380 rpm to 2,700 rpm (CLV)

Error correction

ACIRC (Advanced Cross Interleave Reed Solomon Code)

Sampling frequency

44.1 kHz

Sampling rate converter

Input: 32 kHz/44.1 kHz/48 kHz

Coding

ATRAC (Adaptive TRansform Acoustic Coding)

ATRAC3 — LP2/LP4

Modulation system

EFM (Eight to Fourteen Modulation)

— Continued on next page —

PORTABLE MINIDISC RECORDER

9-873-574-01
2002B0500-1
© 2002.02

Sony Corporation
Personal Audio Company
Published by Sony Engineering Corporation

SONY®

MZ-S1

Number of channels

2 stereo channels
1 monaural channel

Frequency response

20 to 20,000 Hz \pm 3 dB

Wow and Flutter

Below measurable limit

Inputs

Line in: stereo mini-jack, minimum input level
49 mV

Optical (Digital) in: optical (digital) mini-jack

Outputs

⌚: stereo mini-jack, maximum output level
5 mW + 5 mW, load impedance 16 ohm

General

Power requirements

Sony AC Power Adaptor (supplied) connected
at the DC IN 3 V jack (country model in
parentheses):

120 V AC, 60 Hz (USA, Canada)

230 V AC, 50/60 Hz (Continental Europe)

230 - 240 V AC, 50 Hz (UK)

LR6 (size AA) alkaline battery (not supplied)

Dimensions

Approx. 97.3 \times 40 \times 104 mm (w/h/d) (3⁷/₈ \times
1⁵/₈ \times 4¹/₈ in.) (including projects parts and
controls)

Mass

Approx. 215 g (7.6 oz) the main unit only

Supplied accessories

AC power adaptor (1)

Headphones/earphones (1)

USB cable (1)

CD-ROM (1)*

Hand strap (1)

Optical cable (European model only) (1)

Blank Minidisc (US and canadian models only) (1)

* Do not play a CD-ROM on an audio CD player.

Design and specifications are subject to change
without notice.

Battery life¹⁾

(Unit: Approx. hours) (JEITA²⁾)

LR6 (SG) alkaline dry battery ³⁾	Normal	LP2	LP4
Recording ⁴⁾	9	13	16
Playback	40	49	54

¹⁾ The battery life may be shorter due to operating conditions, the temperature of the location, and varieties of batteries.

²⁾ Measured value by the standard of JEITA (Japan Electronics and Information Technology Industries Association).

³⁾ When using a Sony LR6 (SG) "STAMINA" alkaline dry battery (produced in Japan).

⁴⁾ To prevent interrupted recording due to drained battery, use new battery for recording operations.

SAFETY-RELATED COMPONENT WARNING!!

COMPONENTS IDENTIFIED BY MARK \triangle OR DOTTED LINE WITH MARK \triangle ON THE SCHEMATIC DIAGRAMS AND IN THE PARTS LIST ARE CRITICAL TO SAFE OPERATION. REPLACE THESE COMPONENTS WITH SONY PARTS WHOSE PART NUMBERS APPEAR AS SHOWN IN THIS MANUAL OR IN SUPPLEMENTS PUBLISHED BY SONY.

ATTENTION AU COMPOSANT AYANT RAPPORT À LA SÉCURITÉ!

LES COMPOSANTS IDENTIFIÉS PAR UNE MARQUE \triangle SUR LES DIAGRAMMES SCHÉMATIQUES ET LA LISTE DES PIÈCES SONT CRITIQUES POUR LA SÉCURITÉ DE FONCTIONNEMENT. NE REMPLACER CES COMPOSANTS QUE PAR DES PIÈCES SONY DONT LES NUMÉROS SONT DONNÉS DANS CE MANUEL OU DANS LES SUPPLÉMENTS PUBLIÉS PAR SONY.

CAUTION

Use of controls or adjustments or performance of procedures other than those specified herein may result in hazardous radiation exposure.

On power sources

- Use house current, LR6 (size AA) battery.
- For use in your house: Use the AC power adaptor supplied with this recorder. Do not use any other AC power adaptor since it may cause the recorder to malfunction.

Polarity of the plug



Notes on chip component replacement

- Never reuse a disconnected chip component.
- Notice that the minus side of a tantalum capacitor may be damaged by heat.

Flexible Circuit Board Repairing

- Keep the temperature of the soldering iron around 270 °C during repairing.
- Do not touch the soldering iron on the same conductor of the circuit board (within 3 times).
- Be careful not to apply force on the conductor when soldering or unsoldering.

UNLEADED SOLDER

Boards requiring use of unleaded solder are printed with the lead-free mark (LF) indicating the solder contains no lead.
 (Caution: Some printed circuit boards may not come printed with the lead free mark due to their particular size)



LF : LEAD FREE MARK

Unleaded solder has the following characteristics.

- Unleaded solder melts at a temperature about 40 °C higher than ordinary solder.
 Ordinary soldering irons can be used but the iron tip has to be applied to the solder joint for a slightly longer time.
 Soldering irons using a temperature regulator should be set to about 350 °C .
 Caution: The printed pattern (copper foil) may peel away if the heated tip is applied for too long, so be careful!
- Strong viscosity
 Unleaded solder is more viscous (sticky, less prone to flow) than ordinary solder so use caution not to let solder bridges occur such as on IC pins, etc.
- Usable with ordinary solder
 It is best to use only unleaded solder but unleaded solder may also be added to ordinary solder.

TABLE OF CONTENTS

1. SERVICING NOTES	4
2. GENERAL	6
3. DISASSEMBLY	
3-1. Disassembly Flow	7
3-2. Case (Lower) Section	8
3-3. Buckle (Upper) Assy, Battery Case Lid	9
3-4. Case (Upper) Section	10
3-5. Mechanism Deck (MT-MZN707-177)	10
3-6. Set Chassis Assy	11
3-7. MAIN Board	11
3-8. OP Service Assy (LCX-5R)	12
3-9. Holder Assy	13
3-10. DC Motor (Sled) (M602)	13
3-11. DC SSM18B Motor (Spindle) (M601), DC Motor (Over Write Head Up/Down) (M603)	14
3-12. Ornament (R), Switch Unit	14
4. TEST MODE	15
5. ELECTRICAL ADJUSTMENTS	20
6. DIAGRAMS	
6-1. Block Diagram – SERVO/USB Section –	32
6-2. Block Diagram – AUDIO Section –	33
6-3. Block Diagram – DISPLAY/KEY CONTROL/ POWER SUPPLY Section –	34
6-4. Note for Printed Wiring Board and Schematic Diagrams	35
6-5. Printed Wiring Board – MAIN Board (Component Side) –	36
6-6. Printed Wiring Board – MAIN Board (Conductor Side) –	37
6-7. Schematic Diagram – MAIN Board (1/4) –	38
6-8. Schematic Diagram – MAIN Board (2/4) –	39
6-9. Schematic Diagram – MAIN Board (3/4) –	40
6-10. Schematic Diagram – MAIN Board (4/4) –	41
6-11. IC Pin Function Description	48
7. EXPLODED VIEWS	
7-1. Case (Upper) Section	55
7-2. Chassis Section	56
7-3. MAIN Board Section	57
7-4. Case (Lower) Section-1	58
7-5. Case (Lower) Section-2	59
7-6. Mechanism Deck Section-1 (MT-MZN707-177)	60
7-7. Mechanism Deck Section-2 (MT-MZN707-177)	61
8. ELECTRICAL PARTS LIST	62

SECTION 1 SERVICING NOTES

NOTES ON HANDLING THE OPTICAL PICK-UP BLOCK OR BASE UNIT

The laser diode in the optical pick-up block may suffer electrostatic break-down because of the potential difference generated by the charged electrostatic load, etc. on clothing and the human body.

During repair, pay attention to electrostatic break-down and also use the procedure in the printed matter which is included in the repair parts.

The flexible board is easily damaged and should be handled with care.

NOTES ON LASER DIODE EMISSION CHECK

Never look into the laser diode emission from right above when checking it for adjustment. It is feared that you will lose your sight.

NOTES ON HANDLING THE OPTICAL PICK-UP BLOCK (LCX-5R)

The laser diode in the optical pick-up block may suffer electrostatic break-down easily. When handling it, perform soldering bridge to the laser-tap on the flexible board. Also perform measures against electrostatic break-down sufficiently before the operation. The flexible board is easily damaged and should be handled with care. (See Fig.1)

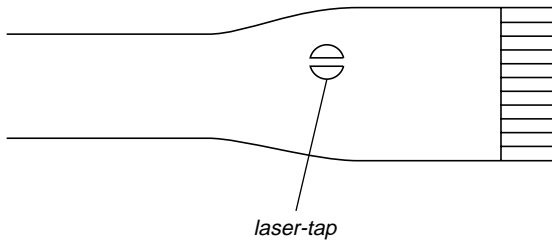

Fig.1 OPTICAL PICK-UP FLEXIBLE BOARD

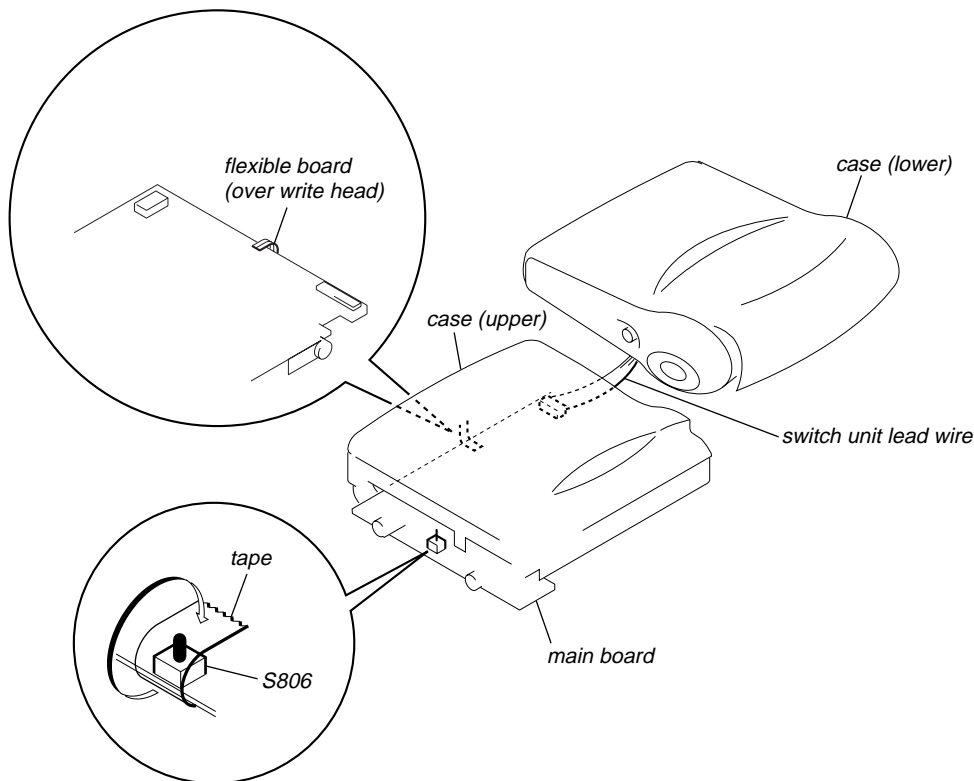

Fig.2

- In performing the repair with the power supplied to the set, removing the MAIN board causes the set to be disabled. In such a case, fix a convex part of the open/close detect switch (S806 on MAIN board) with a tape in advance. Handle the FLEXIBLE board (overwrite head) with care, as it has been soldered directly to the MAIN board. In repairing the component side of MAIN board, connect the FLEXIBLE board (overwrite head) and the MAIN board with the lead wires in advance. (See Fig.2)
- The shipment data will be cleared when the NV is reset. Therefore, change the NV adjusted values following the Change of NV Adjusted Values immediately after the NV was reset. (See page 20)
- This set requires the patch data in the nonvolatile memory (IC804) to be rewritten using the application, when the MAIN board or nonvolatile memory (IC804) was replaced. (See page 30)

System requirements

- IBM PC / AT or Compatible (The software does not run on Macintosh.)
CPU: MMX™ Pentium® 233 MHz or higher (Pentium® II 400 MHz or higher is recommended.)
Hard disk drivespace: 60 MB or more (The amount of necessary space depends on the version of the Windows OS or the size of your audio files.)
RAM: 64 MB or higher (128 MB or higher is recommended for Windows® XP Home Edition / Windows® XP Professional.)
CD-ROM drive (capable of digital playback by WDM)
Sound Board
USB port (supports USB 2.0 Full Speed (previously USB 1.1))
- Operating System: Windows® 98 / Windows® 98 Second Edition / Windows® 2000 Professional / Windows® Me / Windows® XP Home Edition / Windows® XP Professional (manufacturer installed)
The NTFS format of Windows® 2000 Professional, Windows® XP Home Edition, or Windows® XP Professional (manufacturer-installed) is supported only when used with the standard (factory) settings.
This software is not supported by the following environments.
 - Windows® 95, Windows® NT, or other versions of Windows® NT (such as Server)
 - An environment that is an upgrade of the original manufacturer-installed operating system, as in the following examples:
Windows® 3.1 / Windows® 95 → Windows® 98 (or Windows® 98 Second Edition / Windows® Me)
Windows® Me / Windows® 2000 Professional → Windows® XP
 - Multi-boot environment with Windows® 2000 (or Windows® XP) and Windows® 98 (or Windows® 98 Second Edition / Windows® Me)
- Display: High (16bit) Color or more (800 × 480 dot or more)
- Internet access: for Web registration and EMD services
- Internet access: for software upgrades and CDDDB2 use. (US and Canadian models)
- Windows Media Player (version 7.0 or higher) installed for playing WMA files.

Notes

- Trouble-free operation is not assured within a multiple-monitor environment.
- We do not assure trouble-free operation for all computers satisfying the system requirements.
- Trouble-free operation is not guaranteed following the self-conducted upgrade of home-built PCs or operating systems.
- We do not assure trouble-free operation of the system suspend, sleep, or hibernation function on all computers.
- For details, refer to "Net MD Help" of the online help.

Note

The optical digital output connector (on computers provided with one) may be disabled during playback for the protection of copyrights.

Notes on using OpenMG Jukebox with Windows 2000/Windows XP

If your computer is Windows 2000 Professional, Windows XP Home Edition, or Windows XP Professional, please be aware of the following before installing OpenMG Jukebox.

- 1 With Windows 2000 Professional, you must log on as "Administrators" (or with the user name "Administrator") to install OpenMG Jukebox.
- 2 With Windows XP Home Edition or Windows XP Professional, you must log on with user name "Computer Administrator" to install OpenMG Jukebox. To check whether a user name has the attribute of "Computer Administrator" or not, go to [Control Panel] - [User Account].

Notes on using OpenMG Jukebox with Windows XP/Windows Me

If Windows XP/Windows Me is installed in your computer, and you perform the "System Restore" function of the Windows "System Tools," the songs managed by OpenMG Jukebox may become corrupted and rendered unplayable. Therefore, before executing "System Restore," back up the songs using "OpenMG Jukebox Backup Tool" first. Then, after the "System Restore" function is finished, restore the songs using "OpenMG Jukebox Backup Tool" to ensure the integrity and reliability of song playback. For more information about backup, refer to the online Help for OpenMG Jukebox.

Note

When songs become unplayable by executing "System Restore," an error dialog box may be displayed. In this case, follow the displayed messages.

Looking at the controls

Front of the recorder

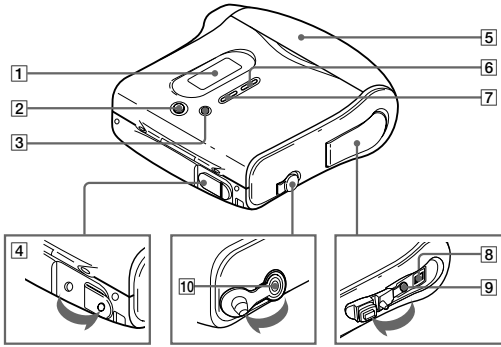

- 1 Display window
- 2 GROUP/CANCEL button
- 3 MENU/ENTER button
- 4 DC IN 3V jack
- 5 Buckle
- 6 T MARK/REC button
- 7 END SEARCH button
- 8 USB connecting jack
- 9 LINE IN (OPTICAL) jack
- 10 (headphones/earphones) jack

Rear of the recorder

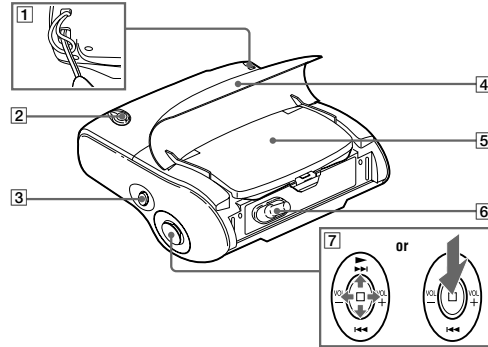

- 1 Hand strap attachment point
- 2 HOLD switch
- 3 (pause) button
- 4 Buckle
- 5 Battery compartment lid
- 6 OPEN switch
- 7 5 way thumb control key
Push the key in any of the four directions or press down the ■ button for various operations.
▶* (play)
◀▶ (search/AMS)
■ (stop)
VOL +*/-
*There is a tactile dot above ▶ and to the right of VOL +.

Using the hand strap

While jogging, use the supplied hand strap. Put your hand between the recorder and the strap, and then hold the recorder as the illustrations below:

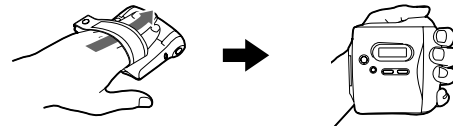

12-GB

13-GB

The display window of the recorder

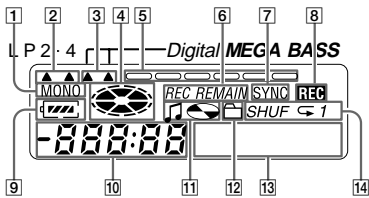

- 1 MONO (monaural) indication
- 2 LP mode indication
- 3 Mega bass indication
- 4 Disc indication
Shows that the disc is rotating for recording, playing or editing an MD.
- 5 Level meter
Shows the volume of the MD being played or recorded.
- 6 REC REMAIN/REMAIN (remaining time/tracks) indication
Lights up along with the remaining time of the track, the remaining time of the MD, or the remaining number of tracks.
- 7 SYNC (synchro-recording) indication
- 8 REC indication
Lights up while recording. When flashing, the recorder is in record standby mode.
- 9 Battery indication
Shows approximate battery condition.
- 10 Time display
- 11 Disc name/track name indication
Lights up when labeling a disc or a track.
- 12 Group indication
Lights up when group mode is on.
- 13 Character information display
Displays the disc and track names, error messages, track numbers, etc.
- 14 Play mode indication
Shows play mode of the MD.

14-GB

SECTION 3 DISASSEMBLY

• This set can be disassembled in the order shown below.

3-1. DISASSEMBLY FLOW

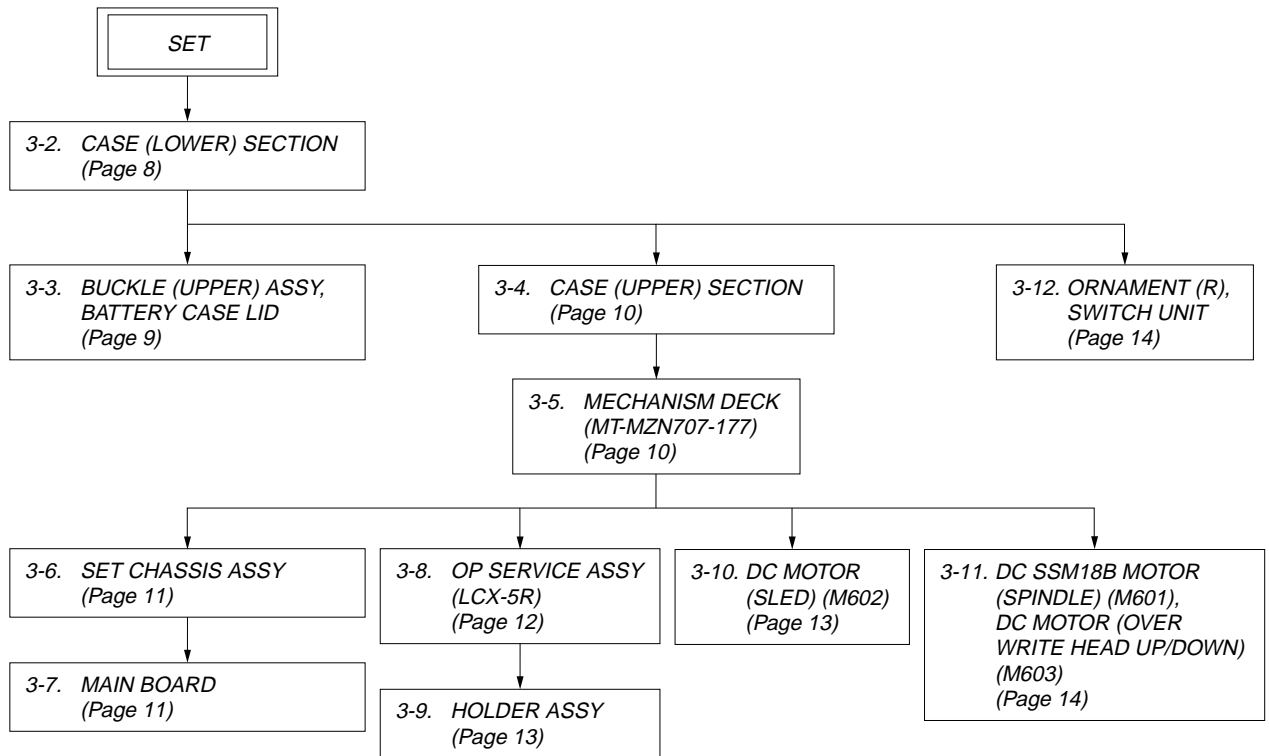

Note: Follow the disassembly procedure in the numerical order given.

3-2. CASE (LOWER) SECTION

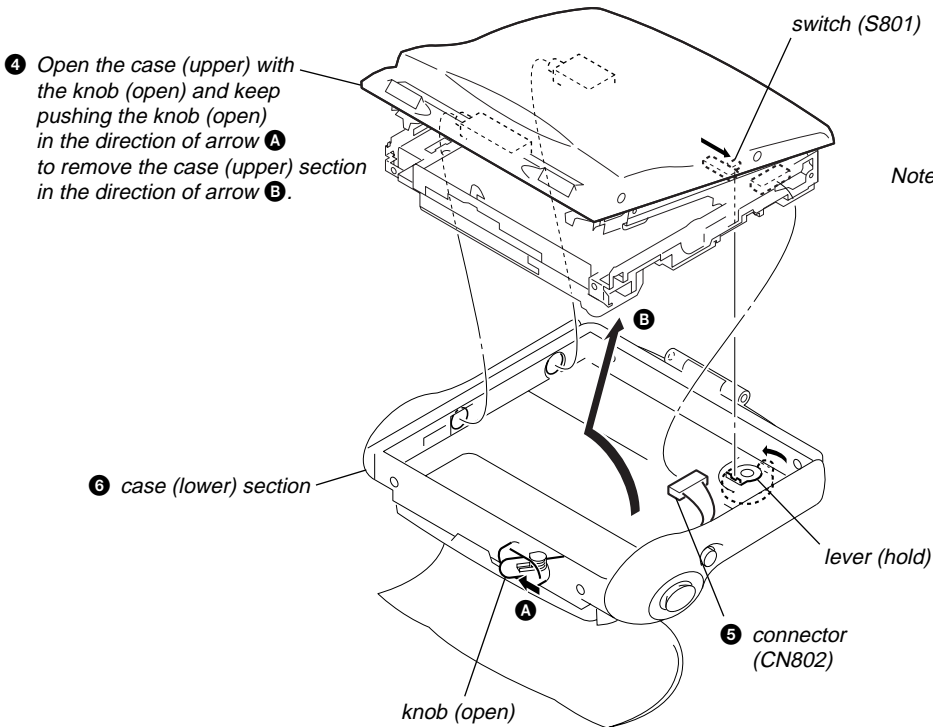
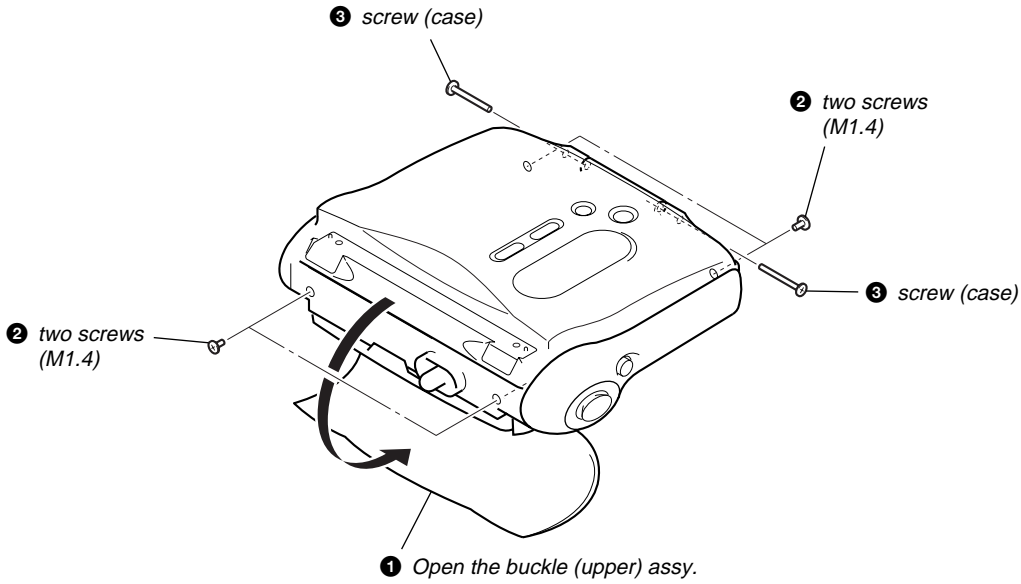

Note: On installation, adjust the position of both switch (S801) and lever (hold).

3-3. BUCKLE (UPPER) ASSY, BATTERY CASE LID

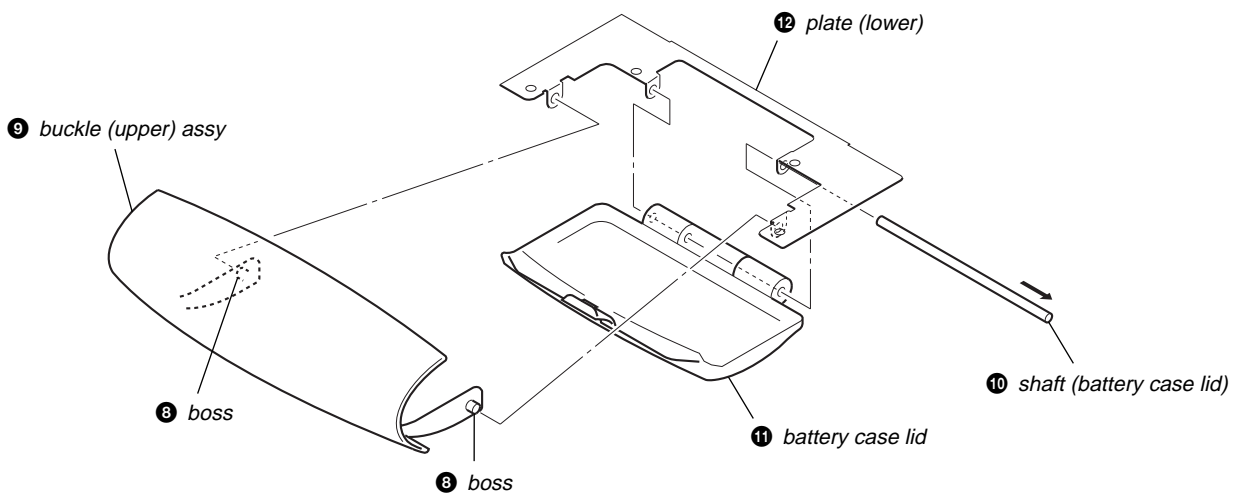
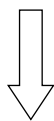
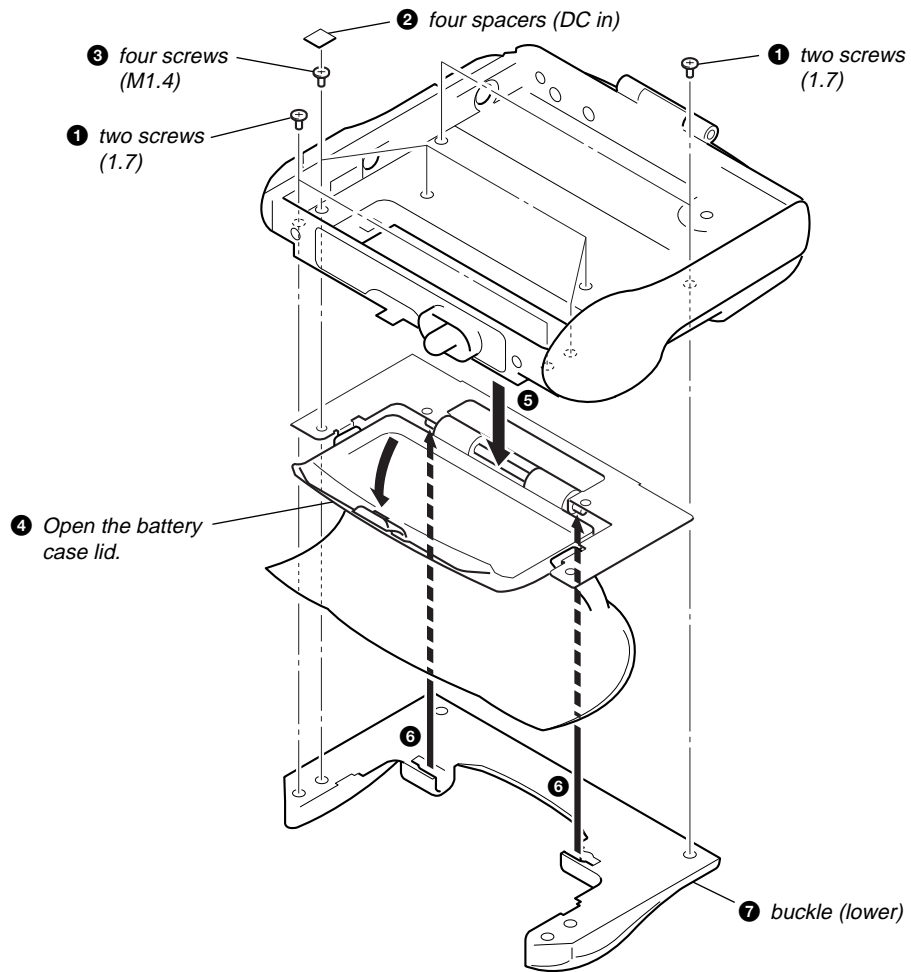

3-4. CASE (UPPER) SECTION

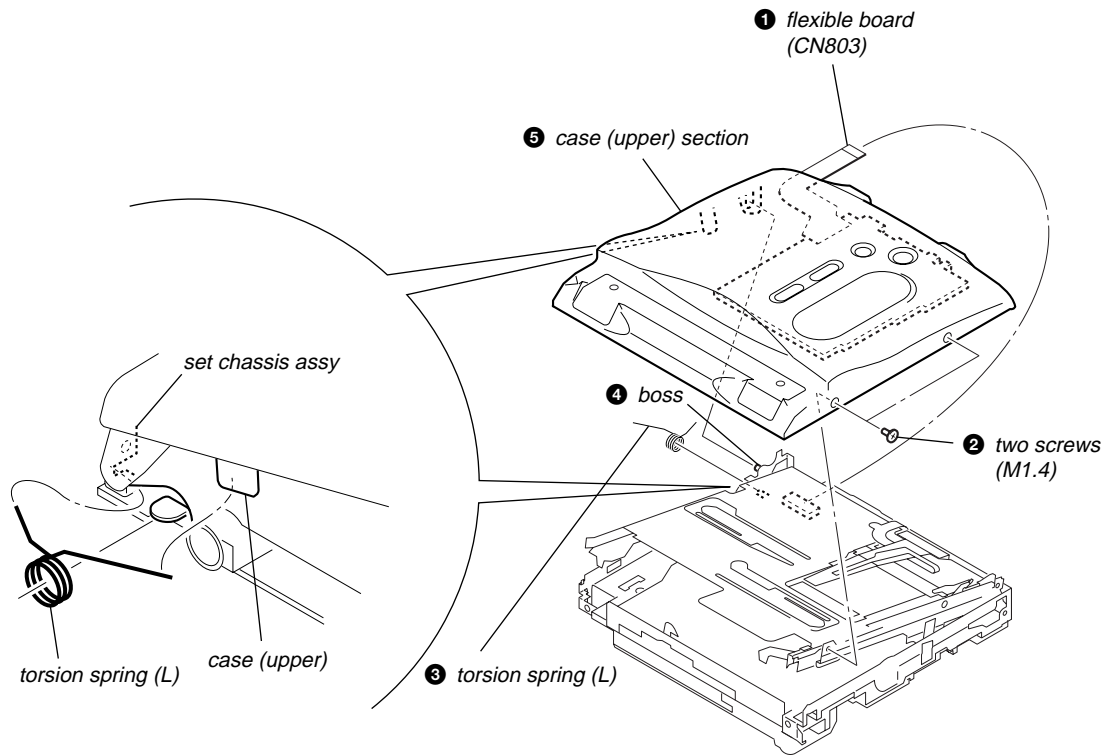

3-5. MECHANISM DECK (MT-MZN707-177)

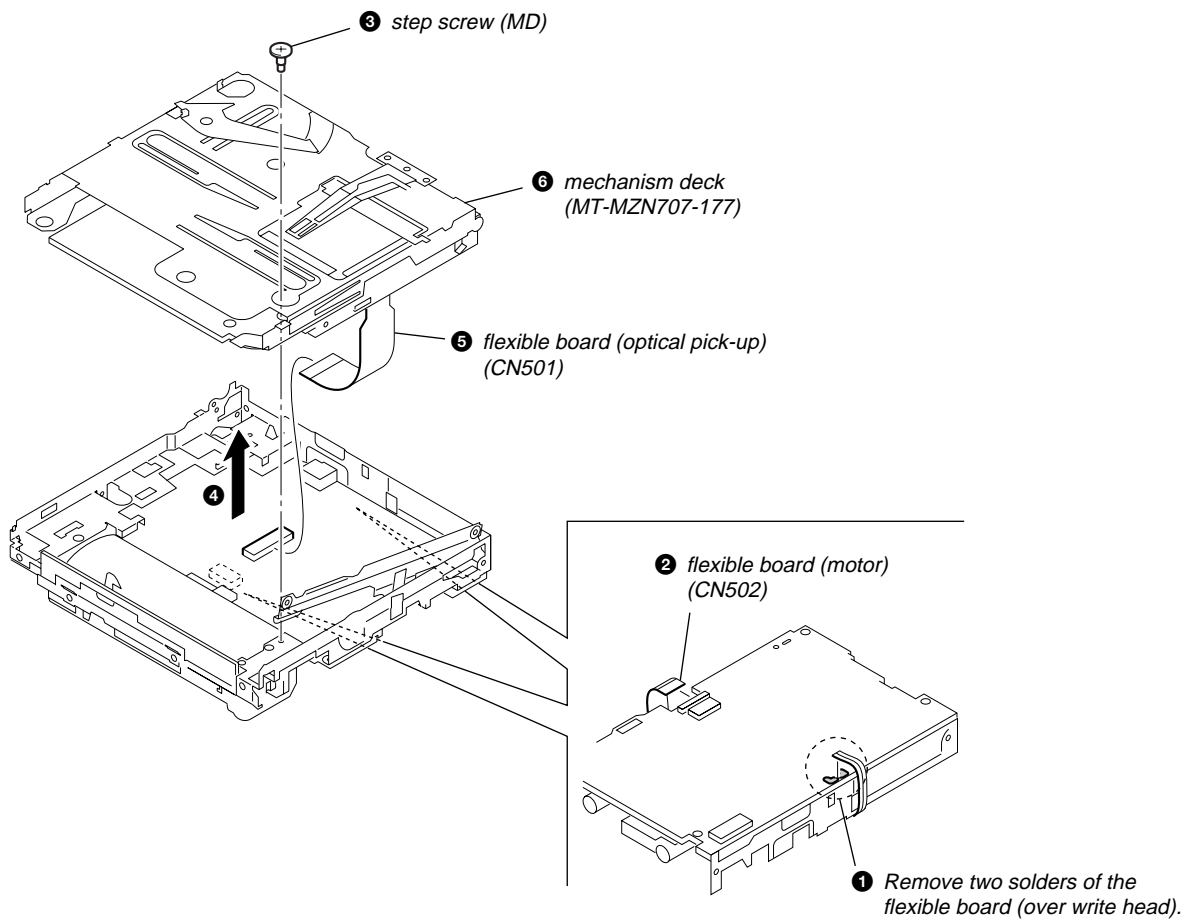

3-6. SET CHASSIS ASSY

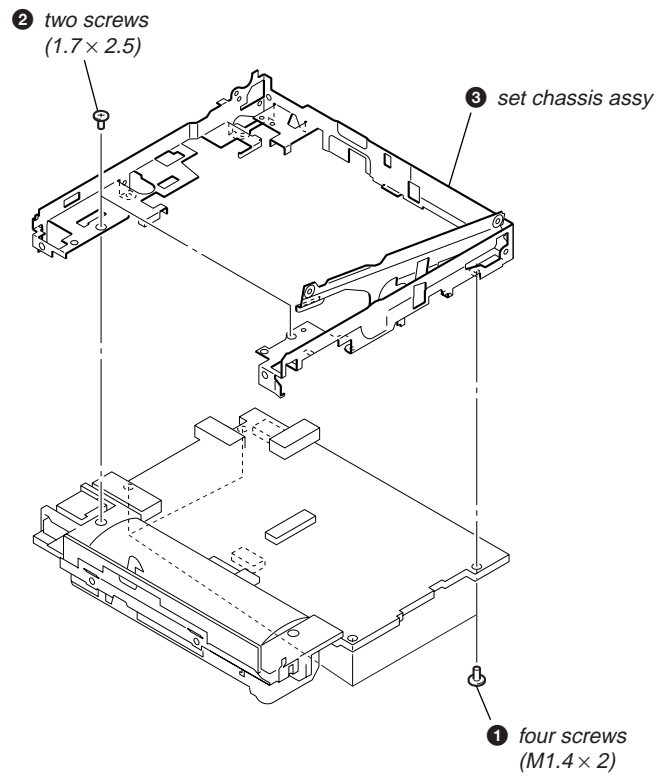

3-7. MAIN BOARD

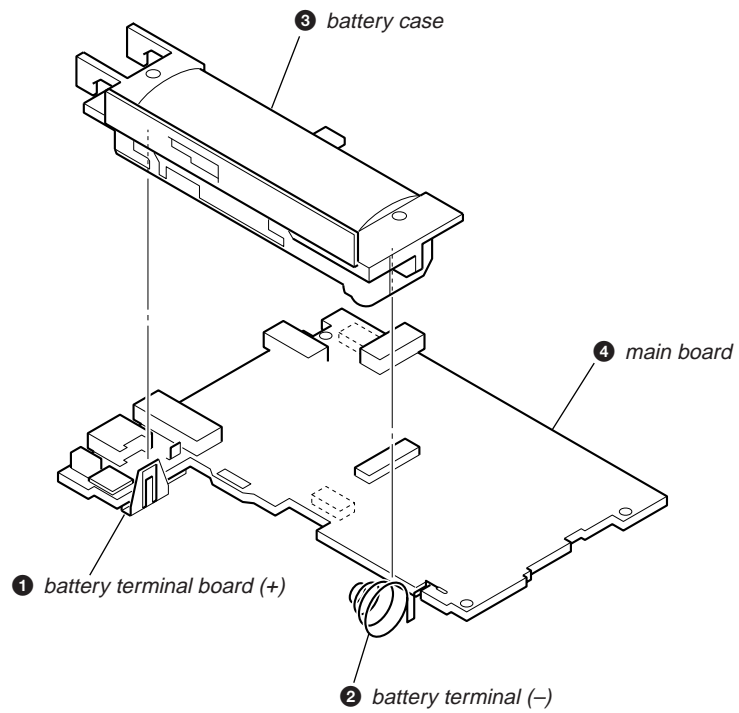

3-8. OP SERVICE ASSY (LCX-5R)

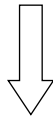
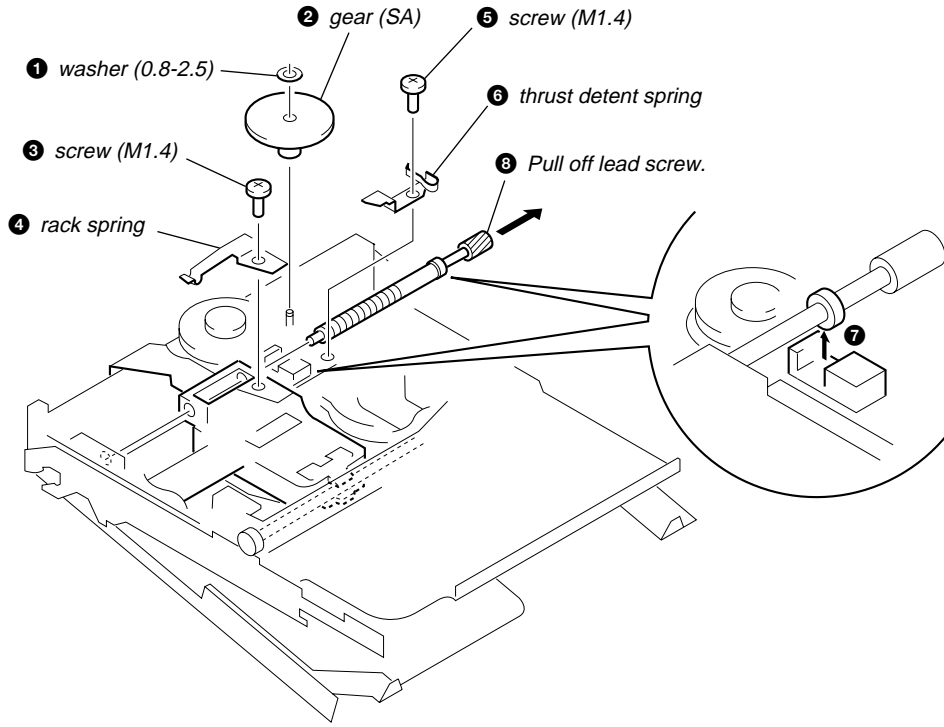

9 Opening the over write head toward the direction **A**, remove the OP service assy (LCX-5R) toward the direction **B**.

Note: Do not open the entire assy forcibly, when opening the over write head.

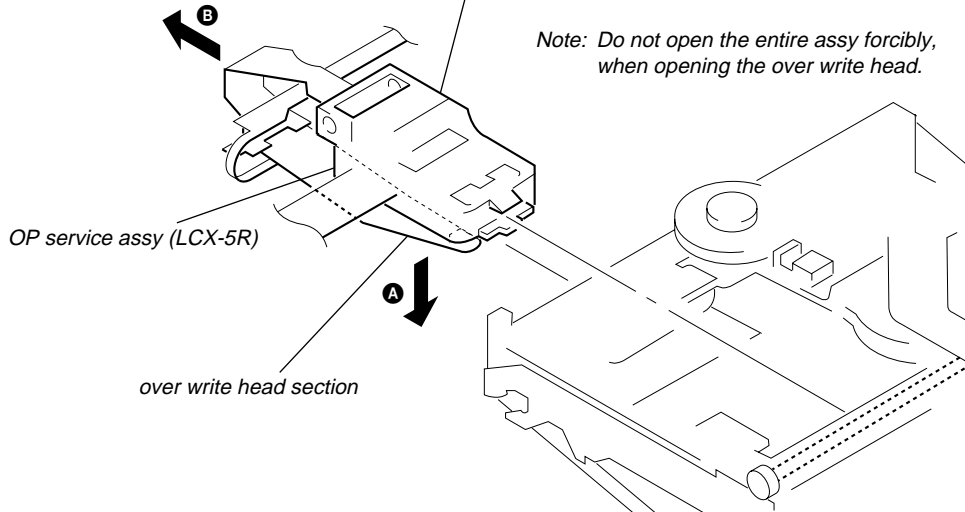

3-9. HOLDER ASSY

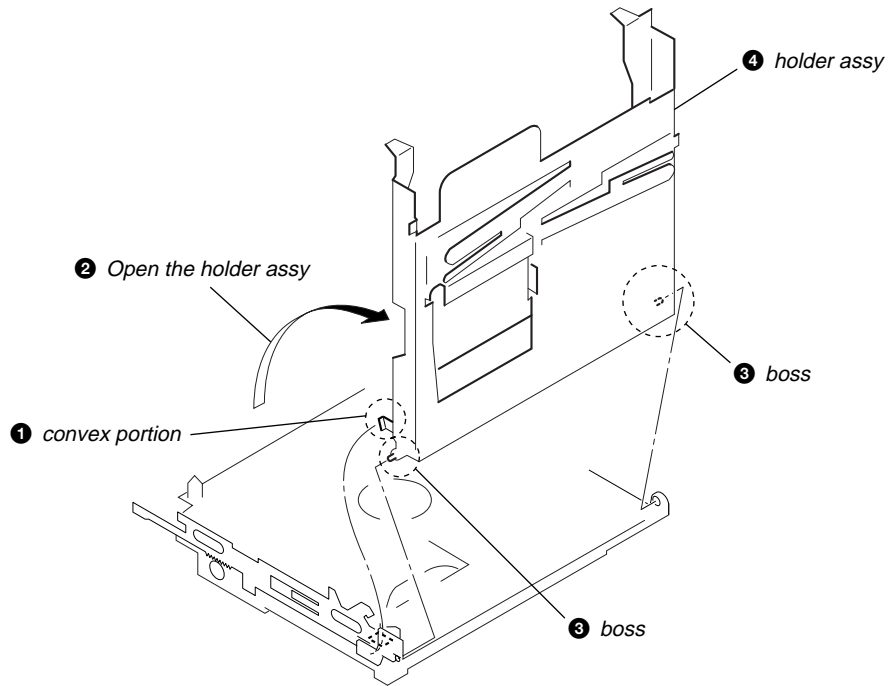

3-10. DC MOTOR (SLED) (M602)

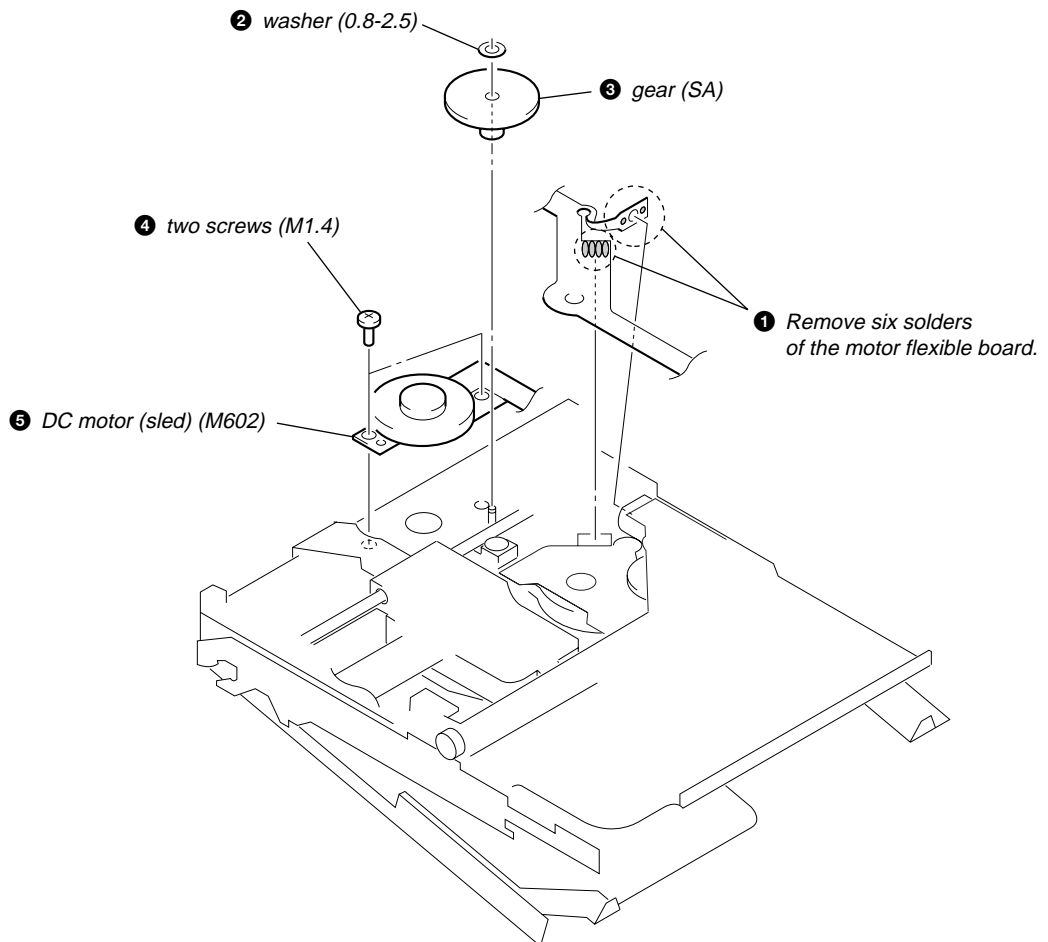

3-11. DC SSM18B MOTOR (SPINDLE) (M601), DC MOTOR (OVER WRITE HEAD UP/DOWN) (M603)

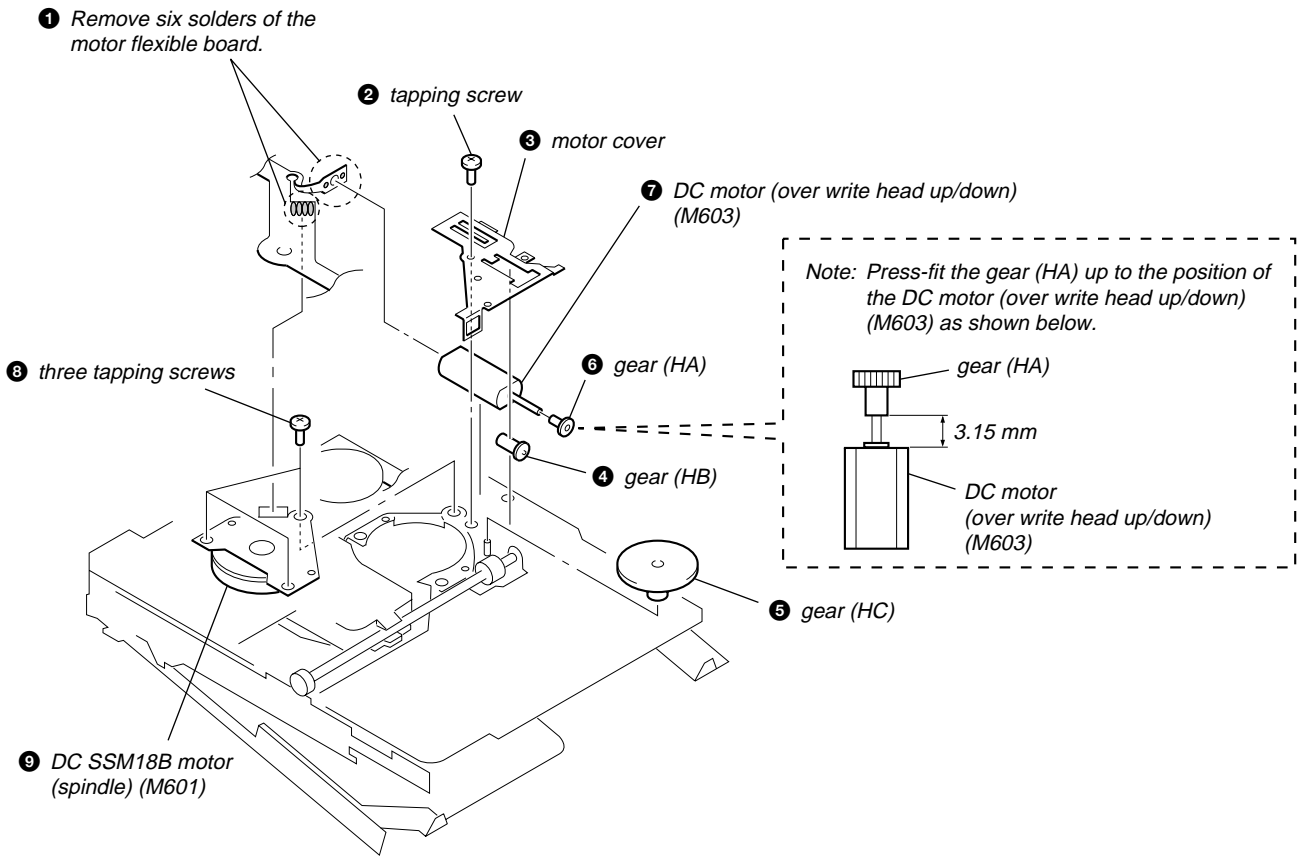

3-12. ORNAMENT (R), SWITCH UNIT

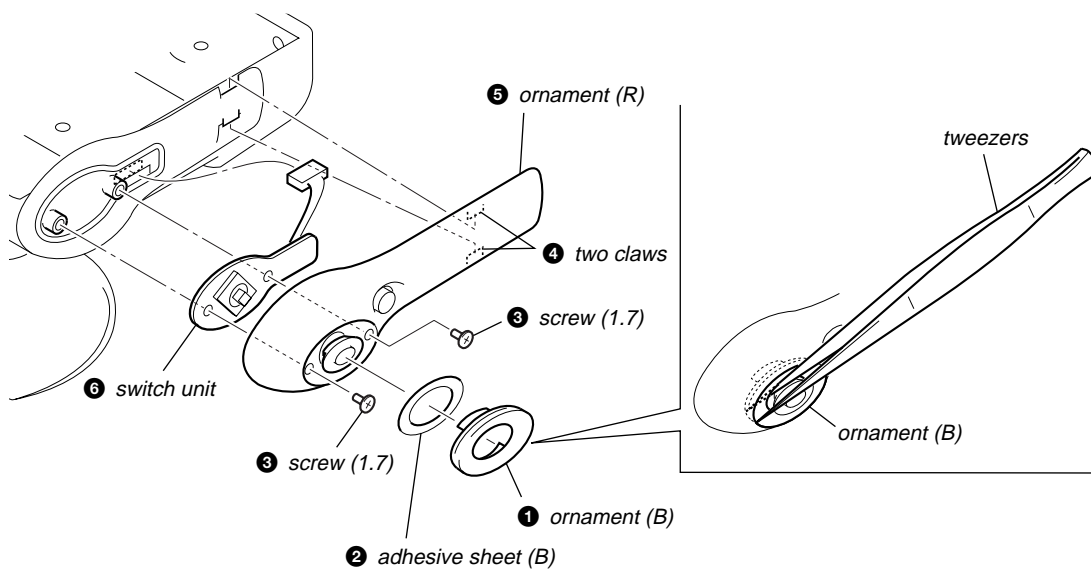

SECTION 4 TEST MODE

OUTLINE

- This set provides the Overall adjustment mode that allows CD and MO discs to be automatically adjusted when in the test mode. In this overall adjustment mode, the disc is discriminate between CD and MO, and each adjustment is automatically executed in order. If a fault is found, the system displays its location. Also, the manual mode allows each individual adjustment to be automatically adjusted.
- Operation in the test mode is performed with the set. A key having no particular description in the text, indicates a set key.

SETTING METHOD OF TEST MODE

There are two different methods to set the test mode:

- ① Short SL801 (TEST) on the MAIN board with a solder bridge (connect pin ⑩ of IC801 to the ground). Then, turn on the power.

– MAIN Board (Conductor Side) –

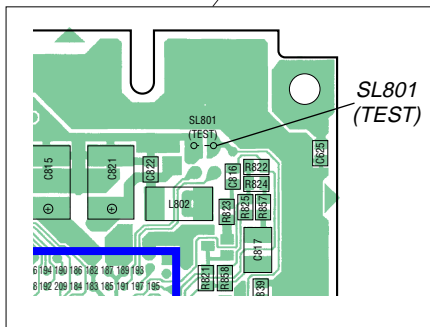
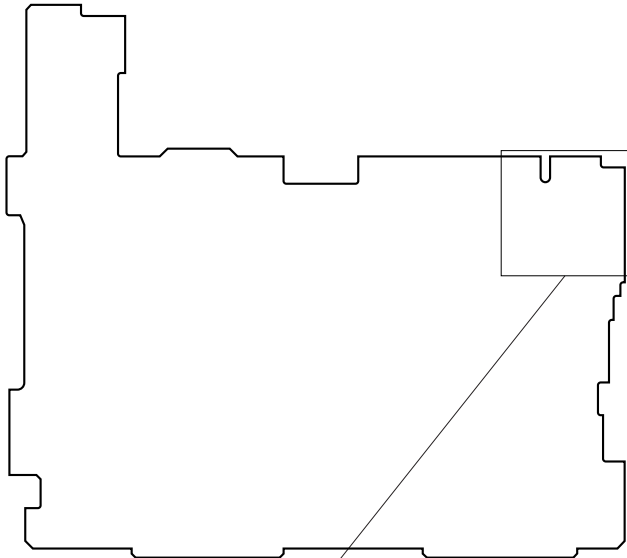

OPERATION IN SETTING THE TEST MODE

- When the test mode becomes active, first the display check mode is selected.
- Other mode can be selected from the display check mode.
- When the test mode is set, the LCD repeats the following display.

Set LCD display

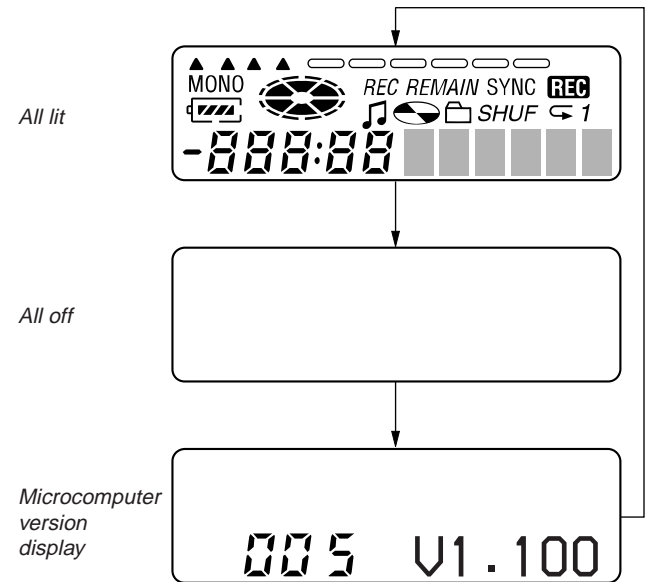

- When the [HOLD] key is pressed and hold down, the display at that time is held so that display can be checked.

RELEASING THE TEST MODE

For test mode set with the method ①:

Turn off the power and open the solder bridge on SL801 (TEST) on the MAIN board.

Note: Remove the solders completely. Remaining could be shorted with the chassis, etc.

For test mode set with the method ②:

Turn off the power.

- ② In the normal mode, turn on the [HOLD] switch. While pressing the [GROUP/CANCEL] key press the following order:

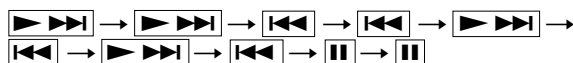

Note: If electrical adjustment (CD and MO overall adjustment) has not been finished completely, “NV Error” is displayed on LCDs of the set and the remote commander.

CONFIGURATION OF TEST MODE

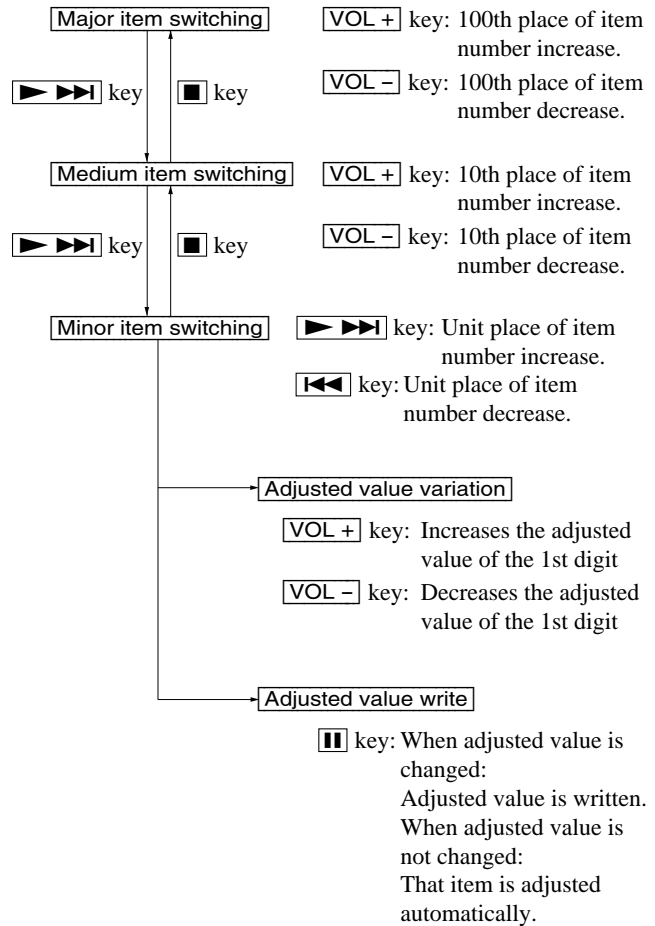
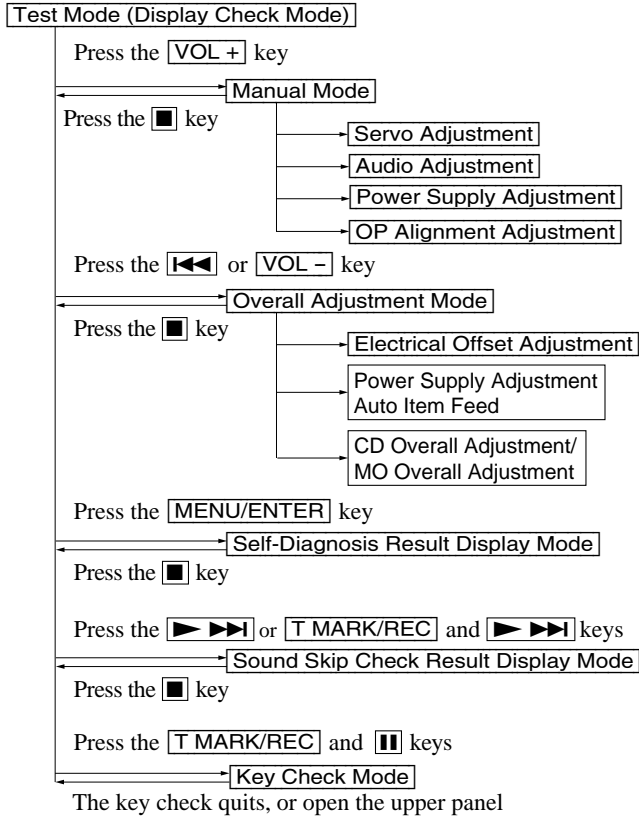

MANUAL MODE

Mode to adjust or check the operation of the set by function. Normally, the adjustment in this mode is not executed. However, the Manual mode is used to clear the memory, power supply adjustment, and laser power check before performing automatic adjustments in the Overall Adjustment mode.

• Transition Method in Manual Mode

1. Set the test mode (see page 15).
2. Press the VOL+ key activates the manual mode where the LCD display as shown below.

Set LCD display



3. During each test, the optical pick-up moves outward or inward while the right arrow or left arrow key is pressed for several seconds respectively.
4. Each test item is assigned with a 3-digit item number; 100th place is a major item, 10th place is a medium item, and unit place is a minor item. The values adjusted in the test mode are written to the nonvolatile memory (for the items where adjustment was made).

5. The display changes as shown below each time the **MENU/ENTER** key .

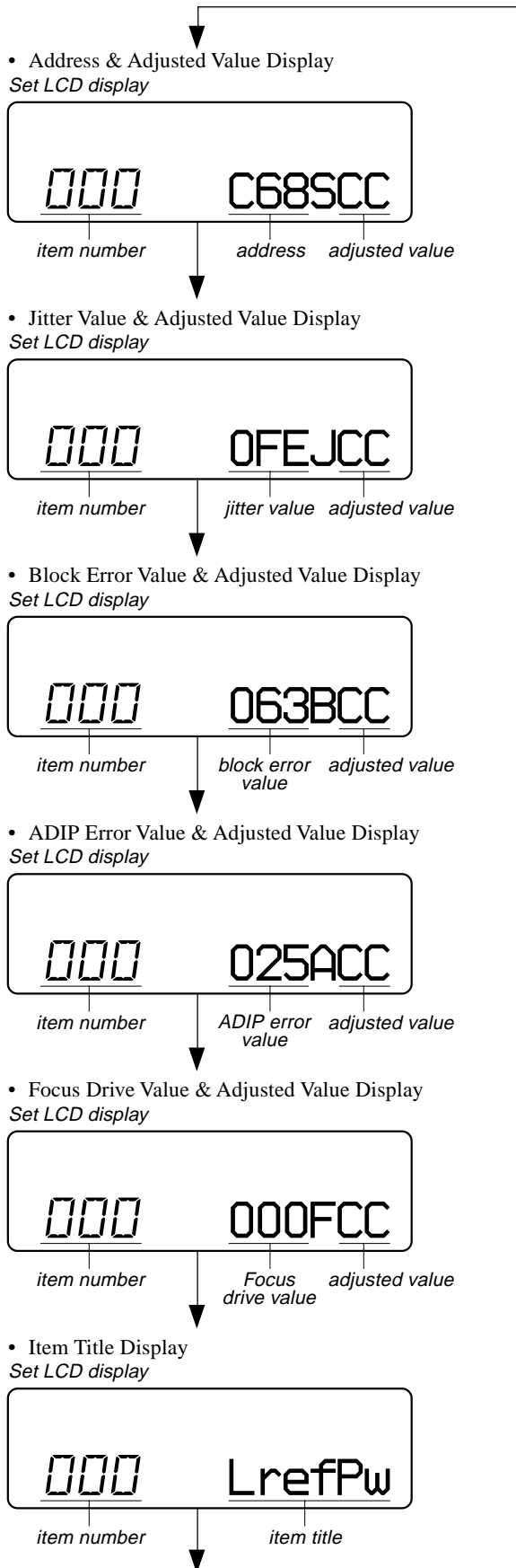

However in the power mode (item number 700's), only the item is displayed.

6. Quit the manual mode, and press the **■** key to return to the test mode (display check mode).

OVERALL ADJUSTMENT MODE

Mode to adjust the servo automatically in all items. Normally, automatic adjustment is executed in this mode at the repair. For further information, refer to "SECTION 5 ELECTRICAL ADJUSTMENTS" (see page 20).

SELF-DIAGNOSIS RESULT DISPLAY MODE

This set uses the self-diagnostic function system in which if an error occurred during the recording or playing, the mechanism control block and the power supply control block in the micro-computer detect it and record its cause as history in the nonvolatile memory.

By checking this history in the test mode, you can analyze a fault and determine its location.

Total recording time is recorded as a guideline of how long the optical pickup has been used, and by comparing it with the total recording time at the time when an error occurred in the self-diagnosis result display mode, you can determine when the error occurred.

Clear both self-diagnosis history data and total recording time, if the optical pickup was replaced.

Self-Diagnosis Result Display Mode Setting Method

1. Set the test mode (see page 15).
2. In the display check mode, **MENU/ENTER** key activates the self-diagnosis result display mode where the LCD display as shown below.

Set LCD display

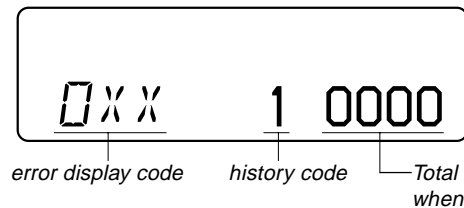

3. Then, each time the **▶▶▶▶** key is pressed, LCD display descends by one as shown below. Also, the LCD display ascends by one when the **◀◀◀◀** key is pressed.

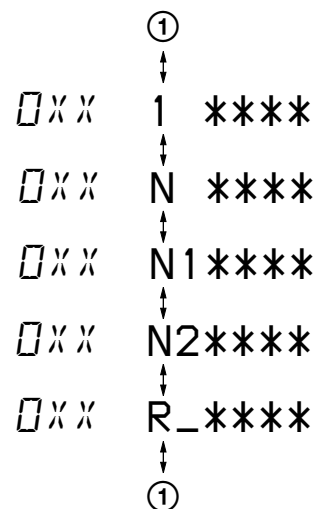

XX : Error code
**** : Total recording time

If the **MENU/ENTER** key is pressed with this display, the LCD switches to the simple display mode.

4. Quit the self-diagnosis result display mode, and press the **■** key to return to the test mode (display check mode).

• Description of Error Indication Codes

Problem	Indication code	Meaning of code	Simple display	Description
No error	00	No error	---	No error
Servo system error	01	Illegal access target address was specified	Adrs	Attempt to access an abnormal address
	02	High temperature	Temp	High temperature detected
	03	Focus error	Fcus	Disordered focus or can not read an address
	04	Spindle error	Spdl	Abnormal rotation of disc
TOC error	11	TOC error	TOC	Faulty TOC contents
	12	Data reading error	Data	Data could not be read at SYNC
Power supply system error	22	Low battery	LBat	Momentary interruption detected
Offset system error	31	Offset error	Ofst	Offset error
	32	Focus error ABCD offset error	ABCD	Focus error ABCD offset error
	33	Tracking error Offset error	TE	Tracking error Offset error
	34	X1 tracking error Offset error	X1TE	X1 tracking error Offset error
Disc error	35	MD DATA 2 disc error	MD2	MD DATA 2 disc error

• Description of Indication History

History code number	Description
1	The first error
N	The last error
N1	One error before the last.
N2	Two errors before the last.
R_	Total recording time

RESET THE ERROR DISPLAY CODE

After servicing, reset the error display code.

• Setting Method of Reset The Error Display Code

1. Set the test mode (see page 15).
2. Press the **[MENU/ENTER]** key activates the self-diagnosis result display mode.
3. To reset the error display code, press the **[II]** key (twice) when the code is displayed (except "R_***").
(All the data on the 1, N, N1, and N2 will be reset)
4. Press the **[■]** key to return to the test mode (display check mode).

SOUND SKIP CHECK RESULT DISPLAY MODE

This set can display the count of errors that occurred during the recording/playing for checking.

• Setting Method of Sound Skip Check Result Display Mode

1. Set the test mode (see page 15).
2. Press the key or [T MARK/REC] and keys, and the playing or recording sound skip result display mode becomes active respectively where the LCD displays the following.

Set LCD display



000 Total count of play system errors (hex.) P**R** Total count of record system errors (hex.)

3. When the key is pressed, total error count is displayed on the LCD, and each time the key is pressed, the display item moves down by one as shown below. Also, if the key is pressed, the display item moves up by one, then if the [T MARK/REC] and keys are pressed, the display in the record mode appears.

When the [T MARK/REC] and keys are pressed, total error count is displayed on the LCD, and each time the key is pressed, the display item moves down by one as shown below. Also, if the key is pressed, the display item moves up by one, then if the key is pressed, the display in the play mode appears.

Playing sound skip result display

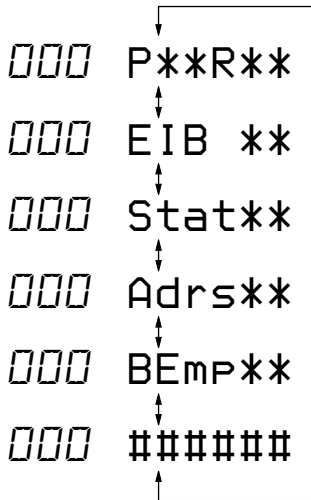

Recording sound skip result display

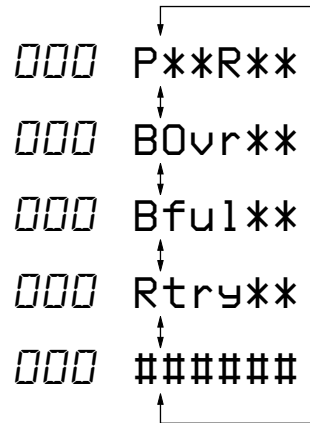

P**R**: Total play/record errors (hex.)
 **: Counter of sound skip check each item (hex.)
 #####: 6-digit address where sound was skipped last (hex.)

• Cause of Sound Skip Error

	Cause of error	Description of error
Play	EIB	Sound error correction error
	Stat	Decoder status error
	Adrs	Address access error
	BEmp	Buffer is empty
Record	BOvr	Buffer is full, and sounds were dumped
	Bful	Buffer capacity becomes less, and forcible writing occurred
	Rtry	Retry times over

4. To quit the sound skip check result display mode and to return to the test mode (display check mode), press the key.

• Setting Method of Key Check Mode

1. Set the test mode (see page 15).
2. Press the [T MARK/REC] and keys on the remote commander activates the key check mode. (At the last two digits, AD value of remote commander key line is displayed in hexadecimal)

Remote commander LCD display



3. When each key on the set is pressed, its name is displayed on the LCD. (The operated position is displayed for 4 seconds after the slide switch is operated. If any other key is pressed during this display, the LCD switches to its name display)

Example1: When the key on the set is pressed:

Set LCD display



4. When all the keys on the set and on the remote commander are considered as OK, the following displays are shown for 4 seconds.

Example2: When the keys on the set are considered as OK:

Set LCD display



5. When all keys were checked or if the upper case is opened, the key check mode quits and the test mode (display check mode) comes back.

SECTION 5 ELECTRICAL ADJUSTMENTS

OUTLINE

- In this set, automatic adjustment of CD and MO can be performed by entering the test mode.
However, before starting automatic adjustment, the memory clear, power supply adjustment, and laser power check must be performed in the manual mode.
- A key having no particular description in the text, indicates a set key.

PRECAUTIONS FOR ADJUSTMENT

1. Adjustment must be done in the test mode only.
After adjusting, release the test mode.
2. Use the following tools and measuring instruments.
 - Test CD disc TDYS-1
(Part No. : 4-963-646-01)
 - SONY MO disc available on the market
 - Digital voltmeter
 - Laser power meter LPM-8001
(Part No. : J-2501-046-A)
 - Thermometer (using the Temperature Correction)
3. Unless specified otherwise, supply DC 3V from the DC IN 3V jack (J601).
4. Switch position
HOLD switch ON

ADJUSTMENT SEQUENCE

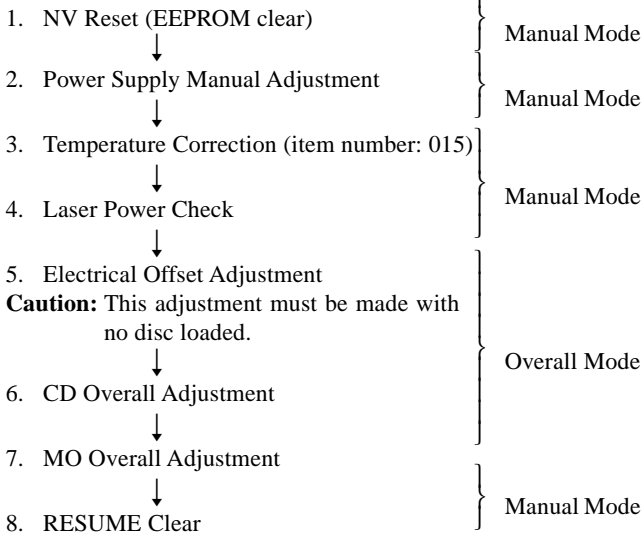

Note: If the version of the microcomputer is 1.000 or later, "3. Temperature Correction" and "2. Power Supply Manual Adjustment" can be performed continuously in reverse order with pressing the **END SEARCH** key in the overall adjustment mode.

NV RESET

Caution: The shipment data will be cleared when the NV is reset. Therefore, change the NV adjusted values following the Change of NV Adjusted Values immediately after the NV was reset.
Change the NV adjustment values according to the microcomputer version.

• Setting Method of NV Reset

1. Select the manual mode of the test mode, and set item number 021 (see page 16).

Remote commander LCD display



####: Address

2. Press the **■** key.

Remote commander LCD display



3. Press the **■** key once more.

Remote commander LCD display



↓ NV reset (after several seconds)

Remote commander LCD display



4. Press the **■** key to quit the manual mode, and return the test mode (display check mode).

• **Change of NV Adjusted Values (version 1.100)**

Caution: Change the NV adjustment values according to the microcomputer version.

In this set, some adjusted values were set in the manual mode at the shipment, but these will be cleared when the NV is reset. Therefore, modify the NV adjusted values through the following procedure immediately after the NV was reset.

1. Item numbers in which the NV adjusted values are to be modified
 - Change ABCD gain [Hpit] initial value (item number 336)
 - Caution:** The ABCD gain [Hpit] initial value must be changed before the overall adjustment.
 - Change BatFlg value (item number 741)
 - Change NiRec0 to 4 values (item numbers 771 to 775)
 - Change NiPb 1 to 4 values (item numbers 776 to 779, 781)
 - Change CLV drive voltage limiter (item numbers 865, 866)
 - Change x2 CLV speed gain, +6dB compared to conventional (item numbers 867, 868)
 - Change x2 CLV phase gain, +3dB compared to conventional (item numbers 871, 872)
 - Change x2/x1 switching temperature threshold value (+10°C → +5°C) (item numbers 873, 874)

2. NV adjusted values modifying procedure
 - 1) Select manual mode of the test mode, and set item number 336 (see page 16).

Set LCD display



###: Address
 **: Adjusted value

- 2) Adjust with the **[VOL +]** key (adjusted value up) or **[VOL -]** key (adjusted value down) so that the adjusted value becomes 08.
- 3) Press the **[F1]** key to write the adjusted value.
- 4) Select manual mode of the test mode, and set item number 741 (see page 16).

Set LCD display



**: Adjusted value

- 5) Adjust with the **[VOL +]** key (adjusted value up) or **[VOL -]** key (adjusted value down) so that the adjusted value becomes 02.
- 6) Press the **[F1]** key to write the adjusted value.
- 7) Select manual mode of the test mode, and set item number 771 (see page 16).

Set LCD display



**: Adjusted value

- 8) Adjust with the **[VOL +]** key (adjusted value up) or **[VOL -]** key (adjusted value down) so that the adjusted value becomes 6E.

- 9) Press the **[F1]** key to write the adjusted value.
- 10) Select manual mode of the test mode, and set item number 772 (see page 16).

Set LCD display



**: Adjusted value

- 11) Adjust with the **[VOL +]** key (adjusted value up) or **[VOL -]** key (adjusted value down) so that the adjusted value becomes 7C.
- 12) Press the **[F1]** key to write the adjusted value.
- 13) Select manual mode of the test mode, and set item number 773 (see page 16).

Set LCD display



**: Adjusted value

- 14) Adjust with the **[VOL +]** key (adjusted value up) or **[VOL -]** key (adjusted value down) so that the adjusted value becomes 7D.
- 15) Press the **[F1]** key to write the adjusted value.
- 16) Select manual mode of the test mode, and set item number 774 (see page 16).

Set LCD display



**: Adjusted value

- 17) Adjust with the **[VOL +]** key (adjusted value up) or **[VOL -]** key (adjusted value down) so that the adjusted value becomes 7E.
- 18) Press the **[F1]** key to write the adjusted value.
- 19) Select manual mode of the test mode, and set item number 775 (see page 16).

Set LCD display



**: Adjusted value

- 20) Adjust with the **[VOL +]** key (adjusted value up) or **[VOL -]** key (adjusted value down) so that the adjusted value becomes 81.
- 21) Press the **[F1]** key to write the adjusted value.
- 22) Select manual mode of the test mode, and set item number 776 (see page 16).

Set LCD display



**: Adjusted value

23) Adjust with the **[VOL +]** key (adjusted value up) or **[VOL -]** key (adjusted value down) so that the adjusted value becomes 5B.

24) Press the **[]** key to write the adjusted value.

25) Select manual mode of the test mode, and set item number 777 (see page 16).

Set LCD display



** : Adjusted value

26) Adjust with the **[VOL +]** key (adjusted value up) or **[VOL -]** key (adjusted value down) so that the adjusted value becomes 7B.

27) Press the **[]** key to write the adjusted value.

28) Select manual mode of the test mode, and set item number 778 (see page 16).

Set LCD display



** : Adjusted value

29) Adjust with the **[VOL +]** key (adjusted value up) or **[VOL -]** key (adjusted value down) so that the adjusted value becomes 7D.

30) Press the **[]** key to write the adjusted value.

31) Select manual mode of the test mode, and set item number 779 (see page 16).

Set LCD display



** : Adjusted value

32) Adjust with the **[VOL +]** key (adjusted value up) or **[VOL -]** key (adjusted value down) so that the adjusted value becomes 7F.

33) Press the **[]** key to write the adjusted value.

34) Select manual mode of the test mode, and set item number 781 (see page 16).

Set LCD display

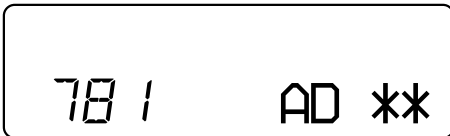

** : Adjusted value

35) Adjust with the **[VOL +]** key (adjusted value up) or **[VOL -]** key (adjusted value down) so that the adjusted value becomes 81.

36) Press the **[]** key to write the adjusted value.

37) Select manual mode of the test mode, and set item number 865 (see page 16).

Set LCD display



: Address

** : Adjusted value

38) Adjust with the **[VOL +]** key (adjusted value up) or **[VOL -]** key (adjusted value down) so that the adjusted value becomes 2C.

39) Press the **[]** key to write the adjusted value.

40) Select manual mode of the test mode, and set item number 866 (see page 16).

Set LCD display



: Address

** : Adjusted value

41) Adjust with the **[VOL +]** key (adjusted value up) or **[VOL -]** key (adjusted value down) so that the adjusted value becomes B9.

42) Press the **[]** key to write the adjusted value.

43) Select manual mode of the test mode, and set item number 867 (see page 16).

Set LCD display



: Address

** : Adjusted value

44) Adjust with the **[VOL +]** key (adjusted value up) or **[VOL -]** key (adjusted value down) so that the adjusted value becomes C9.

45) Press the **[]** key to write the adjusted value.

46) Select manual mode of the test mode, and set item number 868 (see page 16).

Set LCD display

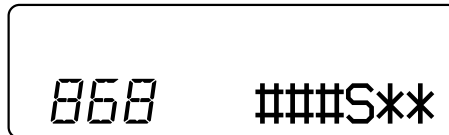

: Address

** : Adjusted value

47) Adjust with the **[VOL +]** key (adjusted value up) or **[VOL -]** key (adjusted value down) so that the adjusted value becomes 80.

48) Press the **[]** key to write the adjusted value.

- 49) Select manual mode of the test mode, and set item number 871 (see page 16).

Set LCD display



####: Address
**: Adjusted value

- 50) Adjust with the **[VOL +]** key (adjusted value up) or **[VOL -]** key (adjusted value down) so that the adjusted value becomes CA.

- 51) Press the **[]** key to write the adjusted value.

- 52) Select manual mode of the test mode, and set item number 872 (see page 16).

Set LCD display

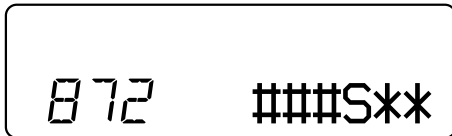

####: Address
**: Adjusted value

- 53) Adjust with the **[VOL +]** key (adjusted value up) or **[VOL -]** key (adjusted value down) so that the adjusted value becomes 2D.

- 54) Press the **[]** key to write the adjusted value.

- 55) Select manual mode of the test mode, and set item number 873 (see page 16).

Set LCD display



####: Address
**: Adjusted value

- 56) Adjust with the **[VOL +]** key (adjusted value up) or **[VOL -]** key (adjusted value down) so that the adjusted value becomes BB.

- 57) Press the **[]** key to write the adjusted value.

- 58) Select manual mode of the test mode, and set item number 874 (see page 16).

Set LCD display

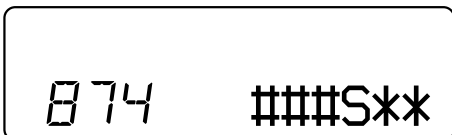

####: Address
**: Adjusted value

- 59) Adjust with the **[VOL +]** key (adjusted value up) or **[VOL -]** key (adjusted value down) so that the adjusted value becomes 05.

- 60) Press the **[]** key to write the adjusted value.

POWER SUPPLY MANUAL ADJUSTMENT

• Adjustment Sequence

Adjustment must be done with the following steps.

1. Vc PWM Duty (L) adjustment (item number: 762)
- ↓
2. Vc PWM Duty (H) adjustment (item number: 763)
- ↓
3. V1 PWM Duty (L) adjustment (item number: 764)
- ↓
4. V1 PWM Duty (H) adjustment (item number: 765)
- ↓
5. Vrec PWM Duty (L) adjustment (item number: 766)
- ↓
6. Vrec PWM Duty (H) adjustment (item number: 767)

• Setting Method of Power Supply Manual Adjustment

1. Make sure that the power supply voltage is 3V.
2. Select the manual mode of the test mode (see page 16).
3. Set item number.

• Adjustment Method of Vc PWM Duty (L) (item number: 762)

Set LCD display



**: Adjusted value

1. Connect a digital voltmeter to the AP912 (VCO) on the MAIN board, and adjust **[VOL +]** key (voltage up) or **[VOL -]** key (voltage down) so that the voltage becomes 2.40 ± 0.05 V.

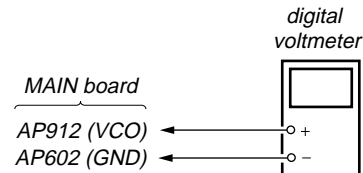

2. Press the **[]** key to write the adjusted value.

Adjustment and Connection Location: MAIN board
(See page 26)

• Adjustment Method of Vc PWM Duty (H) (item number: 763)

Set LCD display



**: Adjusted value

1. Connect a digital voltmeter to the AP912 (VCO) on the MAIN board, and adjust **[VOL +]** key (voltage up) or **[VOL -]** key (voltage down) so that the voltage becomes 2.50 ± 0.05 V.

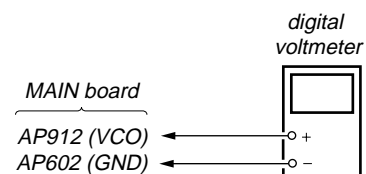

2. Press the **[F4]** key to write the adjusted value.

Adjustment and Connection Location: MAIN board
(See page 26)

• **Adjustment Method of VI PWM Duty (L)**
(item number: 764)

Set LCD display



** : Adjusted value

1. Connect a digital voltmeter to the AP913 (VLO) on the MAIN board, and adjust **[VOL +]** key (voltage up) or **[VOL -]** key (voltage down) so that the voltage becomes 2.30 ± 0.01 V.

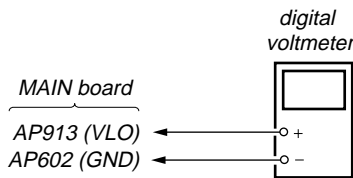

2. Press the **[F4]** key to write the adjusted value.

Adjustment and Connection Location: MAIN board
(See page 26)

• **Adjustment Method of VI PWM Duty (H)**
(item number: 765)

Set LCD display



** : Adjusted value

1. Connect a digital voltmeter to the AP913 (VLO) on the MAIN board, and adjust **[VOL +]** key (voltage up) or **[VOL -]** key (voltage down) so that the voltage becomes 2.55 ± 0.01 V.

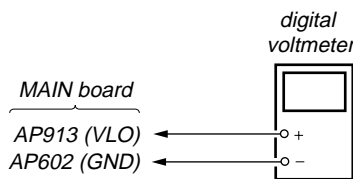

2. Press the **[F4]** key to write the adjusted value.

Adjustment and Connection Location: MAIN board
(See page 26)

• **Adjustment Method of Vrec PWM Duty (L)**
(item number: 766)

Set LCD display

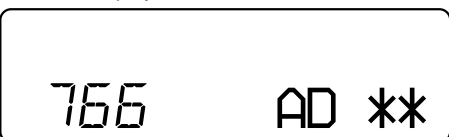

** : Adjusted value

1. Connect a digital voltmeter to the AP605 (VREC) on the MAIN board, and adjust **[VOL +]** key (voltage up) or **[VOL -]** key (voltage down) so that the voltage becomes 1.13 ± 0.02 V.

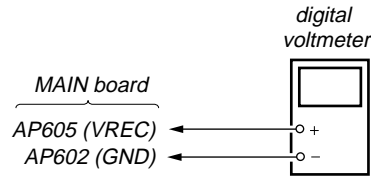

2. Press the **[F4]** key to write the adjusted value.

Adjustment and Connection Location: MAIN board
(See page 26)

• **Adjustment Method of Vrec PWM Duty (H)**
(item number: 767)

Set LCD display



** : Adjusted value

1. Connect a digital voltmeter to the AP605 (VREC) on the MAIN board, and adjust **[VOL +]** key (voltage up) or **[VOL -]** key (voltage down) so that the voltage becomes 1.65 to 1.75 V.

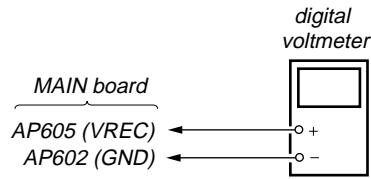

2. Press the **[F4]** key to write the adjusted value.

Adjustment and Connection Location: MAIN board
(See page 26)

TEMPERATURE CORECTION

• **Adjustment Method of Temperature Correction**

1. Select the manual mode of test mode, and set the item number 015 (see page 16).

Set LCD display

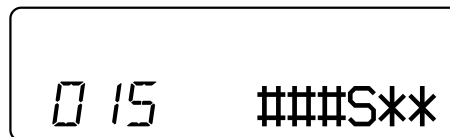

: Address

** : Adjusted value

2. Measure the ambient temperature.
3. Adjust with **[VOL +]**, **[VOL -]** key so that the adjusted value (hexadecimal value) becomes the ambient temperature.
(Initial value: 19h = 25 °C, Adjusting range: 80h to 7fh (-128 °C to +127 °C))
4. Press the **[F4]** key to write the adjusted value.

LASER POWER CHECK

• **Connection**

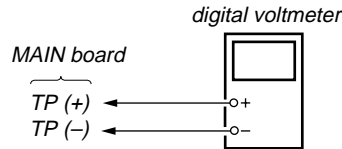
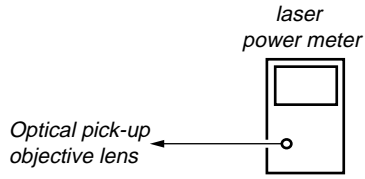

• **Checking Method**

1. Select the manual mode of test mode (see page 16), and set the laser power adjusting mode (item number 010).

Set LCD display



2. Press the [◀◀] key continuously until the optical pick-up moves to the most inward track.
3. Open the cover and set the laser power meter on the objective lens of the optical pick-up.
4. Press the [▶▶▶] key, and set the laser MO read adjustment mode (item number 011).

Set LCD display

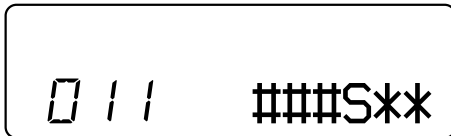

###: Address
**: Adjusted value

5. Check that the laser power meter reading is 0.81 ± 0.08 mW.
6. Check that the voltage both ends (TP (+) and TP (-)) of resistor R521 at this time is below 44 mV.
7. Press the [▶▶▶] key, and set the laser CD read adjustment mode (item number 012).

Set LCD display

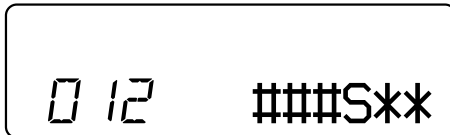

###: Address
**: Adjusted value

8. Check that the laser power meter reading is 0.97 ± 0.10 mW.
9. Check that the voltage both ends (TP (+) and TP (-)) of resistor R521 at this time is below 44 mV.
10. Press the [▶▶▶] key, and set the laser MO write adjustment mode (item number 013).

Set LCD display

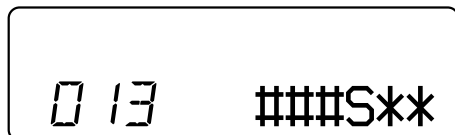

###: Address
**: Adjusted value

11. Check that the laser power meter reading is 4.95 ± 0.50 mW.
12. Check that the voltage both ends (TP (+) and TP (-)) of resistor R521 at this time is below 80 mV.
13. Press the [■] key to quit the manual mode, and activate the test mode (display check mode).

Checking and Connection Location: MAIN board (See page 26)

OVERALL ADJUSTMENT MODE

• Configuration of Overall Adjustment Mode

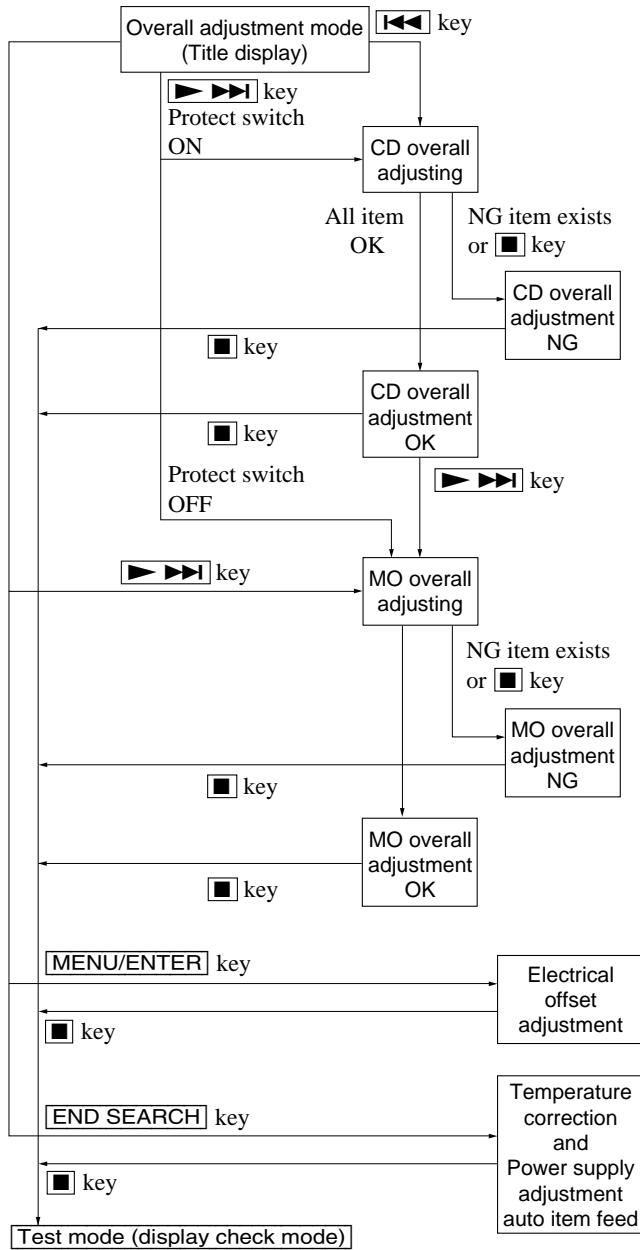

• Overall adjustment mode (title display)

Set LCD display



- ☉ : (Disc mark) At end of power supply adjustment: Outside lit
At end of electrical offset adj.: Inside lit
- ** : Left side = MO overall adjustment information
F*: MO overall adjustment completed
1*: Manual adjustment exists (overall adj. not completed)
0*: Not adjusted
- Right side = CD overall adjustment information
*F: CD overall adjustment completed
*1: Manual adjustment exists (overall adj. not completed)
*0: Not adjusted

Note: Adjust the CD first, when performing adjustment.

• Electrical offset adjusting method

Caution: The electrical offset adjustment must be made with no disc loaded.

1. Make sure that the power supply voltage is 3 V.
2. Set the test mode (see page 15).
3. Press the [left arrow] or [VOL-] key to activate the overall adjustment mode.

Set LCD display



4. Press the [MENU/ENTER] key on the remote commander.

Set LCD display

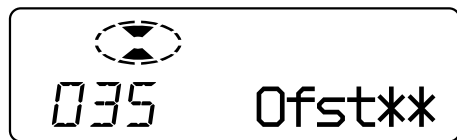

5. Electrical offset adjustment is over, if the following display appears.

Set LCD display

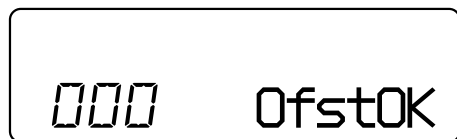

• Adjustment Method of CD and MO Overall Adjustment Mode

1. Set the test mode (see page 15).
2. Press the [left arrow] or [VOL-] key to activate the overall adjustment mode.

Set LCD display



3. Insert CD disc in the set, and press the  key to set the CD overall adjustment mode. Automatic adjustments are made.

Set LCD display



XXX: Item number for which an adjustment is being executed.

4. In case of CD overall adjustment NG, reset the NV (see page 20), then readjust from the temperature correction (see page 24).

Set LCD display

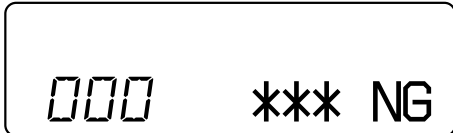

***: NG item number.

5. If OK through the CD overall adjustments, then perform MO overall adjustments.

Set LCD display



6. Insert MO disc in the set, and press the  key to set the MO overall adjustment mode. Automatic adjustments are made.

Set LCD display



XXX: Item number for which an adjustment is being executed.

7. In case of MO overall adjustment NG, reset the NV (see page 20), then readjust from the temperature correction (see page 24).

Set LCD display.

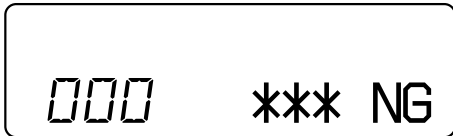

***: NG item number

8. If OK through the MO overall adjustments, press the  key to return to the test mode and terminate the overall adjustment mode.

Set LCD display



• CD and MO Overall Adjustment Items

1. CD overall adjustment items

Item No.	Description
312	CD electrical offset adjustment
313	
314	
321	CD tracking error gain adjustment
328	CD TWPP gain adjustment
324	CD tracking error offset adjustment
332	
336	CD ABCD gain adjustment
344	CD focus gain adjustment
345	CD tracking gain adjustment
521	CD two-axis sensitivity adjustment
522	

2. MO overall adjustment items

Item No.	Description
112	MO electrical offset adjustment
113	
114	
118	
221	Low reflective CD tracking error gain adjustment
224	Low reflective CD tracking error offset adjustment
232	
236	Low reflective CD ABCD gain adjustment
244	Low reflective CD focus gain adjustment
245	Low reflective CD tracking gain adjustment
121	MO tracking error gain adjustment
122	MO TON offset adjustment
134	MO TWPP gain adjustment
131	MO triple speed read TWPP offset adjustment
132	
136	MO ABCD gain adjustment
144	MO focus gain adjustment
145	MO tracking gain adjustment
138	MO RF gain adjustment
434	MO write TWPP gain adjustment
431	MO write TWPP offset adjustment
432	MO tracking error offset adjustment
436	MO write ABCD gain adjustment
445	MO write tracking gain adjustment
411	MO normal speed read TWPP offset adjustment
412	MO tracking error offset adjustment
448	20 sec full recording

RESUME CLEAR

Perform the Resume clear when all adjustments completed.

- **Resume Clear Setting Method**

1. Select the manual mode of the test mode, and set item number 043 (see page 16).

Set LCD display



###: Address

2. Press the  key.

Set LCD display



↓ Resume clear complete



3. Press the  key to return to the test mode (display check mode).

REWRITING THE PATCH DATA AT REPLACEMENT OF MAIN BOARD OR NONVOLATILE MEMORY (IC804)

This set requires the patch data in the nonvolatile memory (IC804) to be rewritten using the application, when the MAIN board or nonvolatile memory (IC804) was replaced.

Caution: The application that meets the microcomputer version in this set must be used when rewriting the patch data. Rewriting the patch data using the application not suitable for the microcomputer version could cause the set to malfunction.
For a checking method of the microcomputer version, see “SECTION 4 TEST MODE” (page 15).

• Preparation

1. USB cable (attached to the set)
2. Personal computer in which the Net MD Driver has been installed. (For further information, see “System requirements” (page 5) in “SECTION 1 SERVICING NOTES”)
3. Application “PatchWriter” for patch data rewriting

• How to Get the Application “PatchWriter” for Patch Data Rewriting

Contact our service technical support division to get the application.

• Pre-Check

1. Check the microcomputer version in this set. (For a checking method of the microcomputer version, see “SECTION 4 TEST MODE” (page 15).)
2. Check that the Net MD Driver has been installed in the personal computer.
3. Make sure that the set is in the Normal mode.
Note: Do not rewrite the patch data in the Test mode.

• Rewriting the Patch Data

1. Connect the set to the personal computer with the USB cable.
2. Start the application “PatchWriter”.
3. Make sure that the following window opens.
4. Click the [Usb Connect] button.

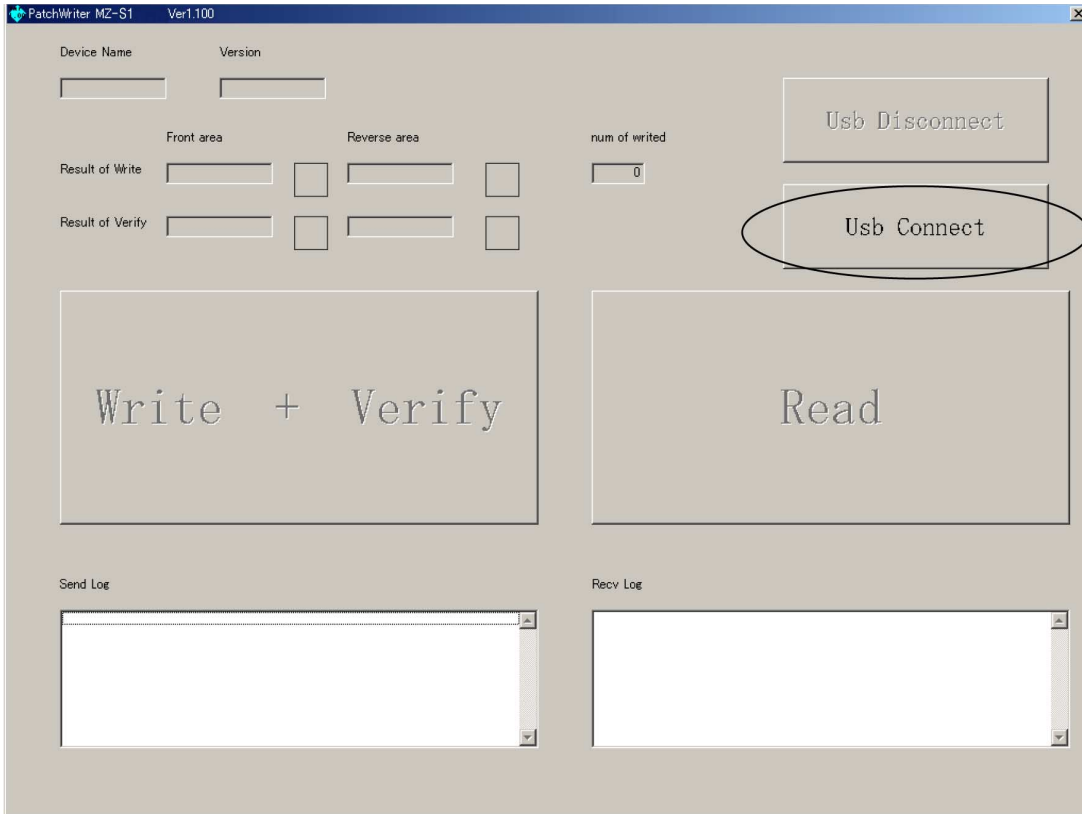

5. Confirm that the model and version indicated on the title bar coincide with the codes displayed in the Device Name block and the Version block in the window.

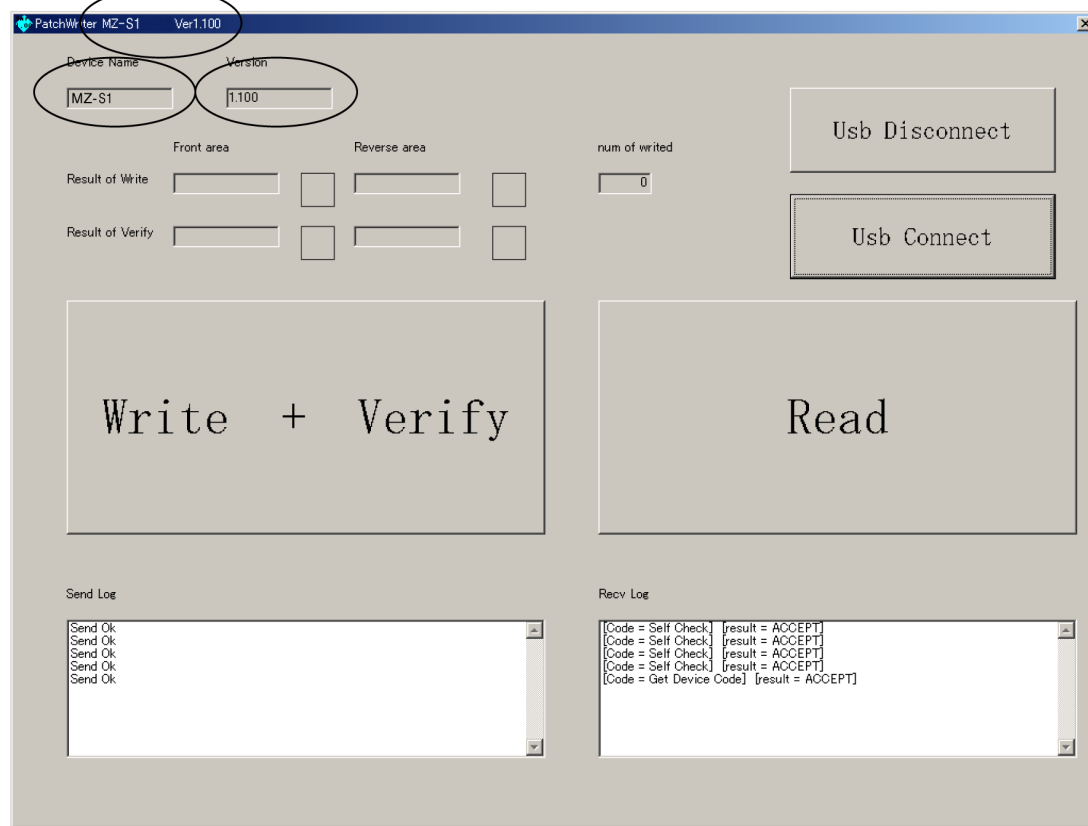

6. Click the [Write + Verify] button.
 The patch data writing and the verify processing will be executed automatically in the following order:
 1) Writing to patch area (front area)
 2) Writing to patch area (reverse area)
 3) Verifying patch area (front area)
 4) Verifying patch area (reverse area)
 7. The operation will terminate with the ○ mark given to all areas.
 If the × mark is given to any area, the nonvolatile memory will be faulty.

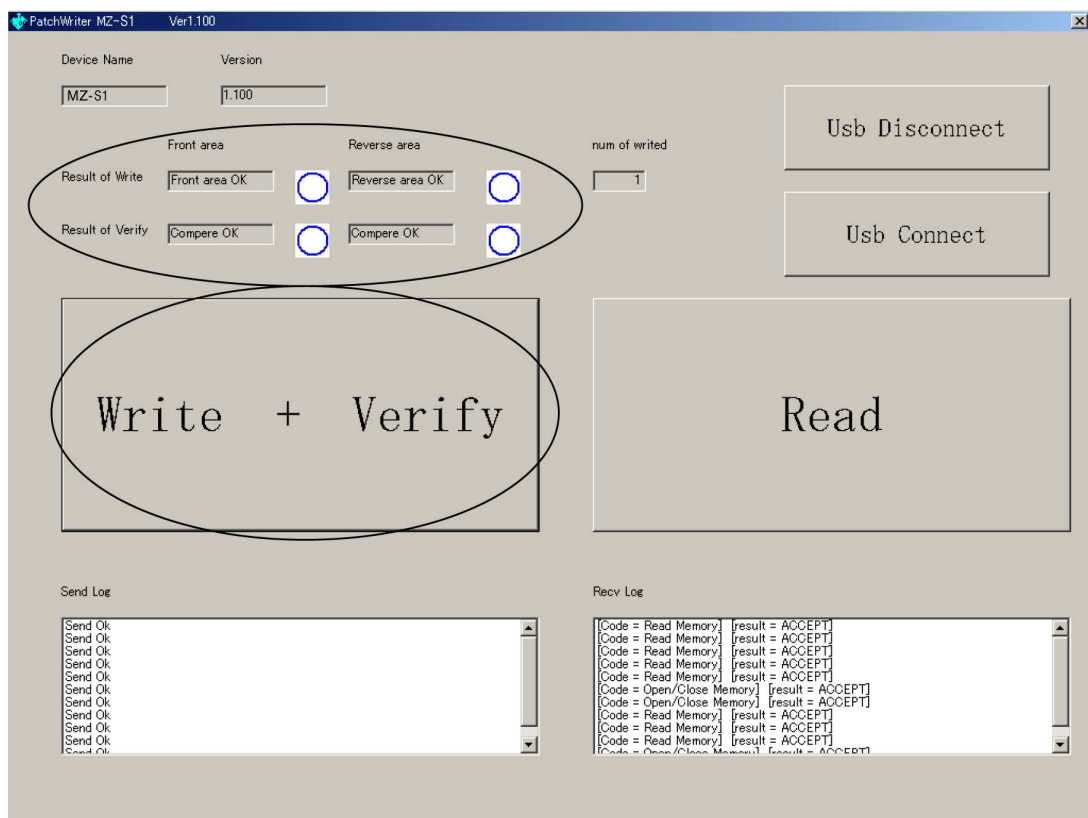

8. Click the [Usb Disconnect] button.

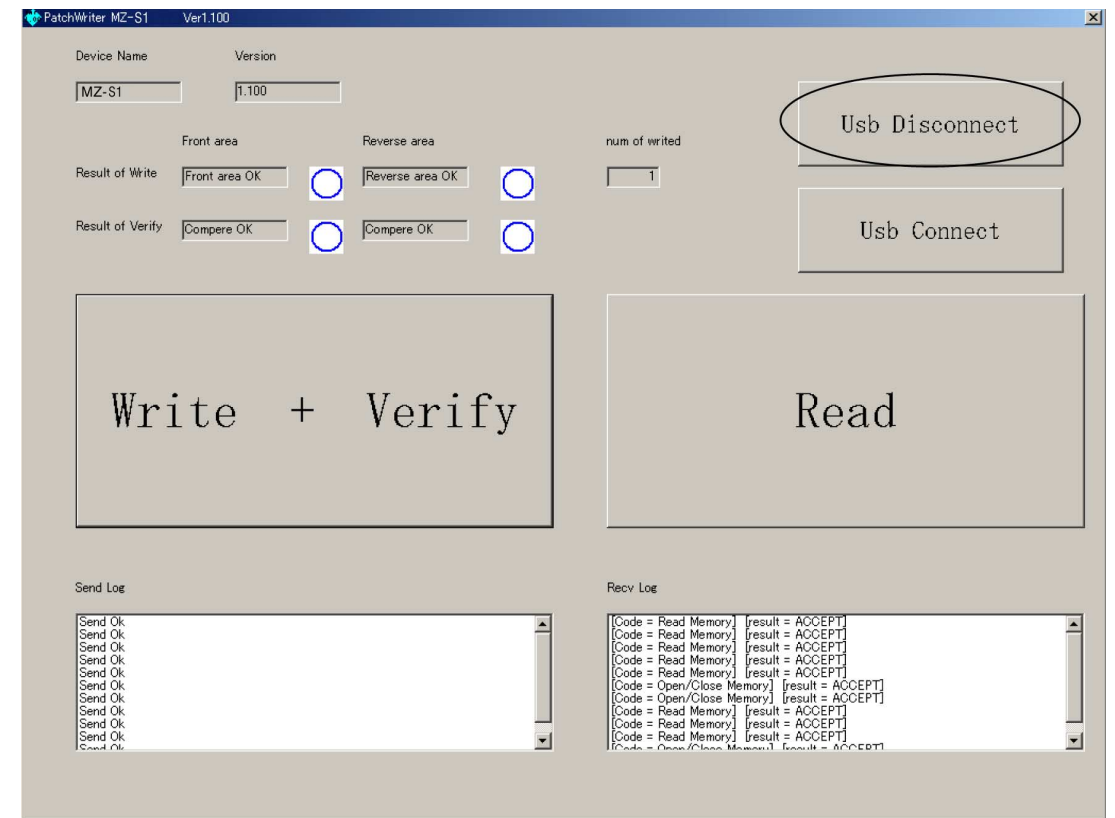

9. Confirm that the window becomes as shown below where the [Write + Verify] button and [Read] button are inactive.

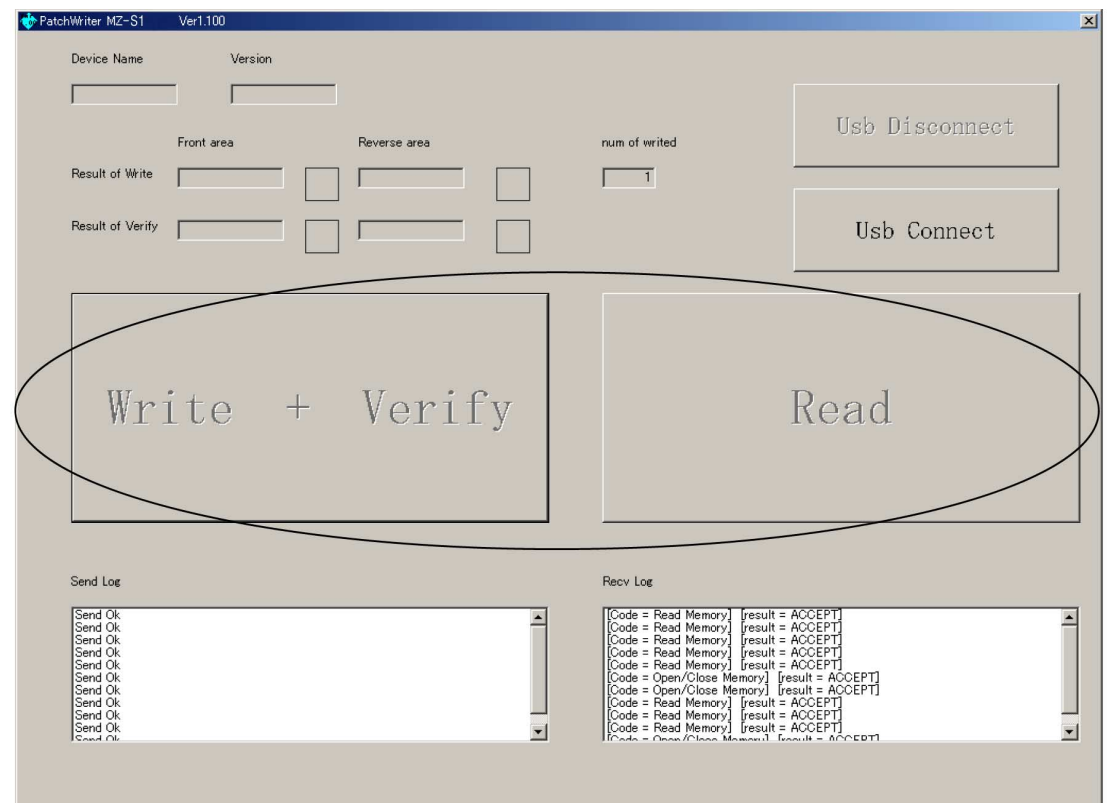

10. Disconnect the USB cable from the personal computer and the set.

SECTION 6 DIAGRAMS

6-1. BLOCK DIAGRAM – SERVO/USB Section –

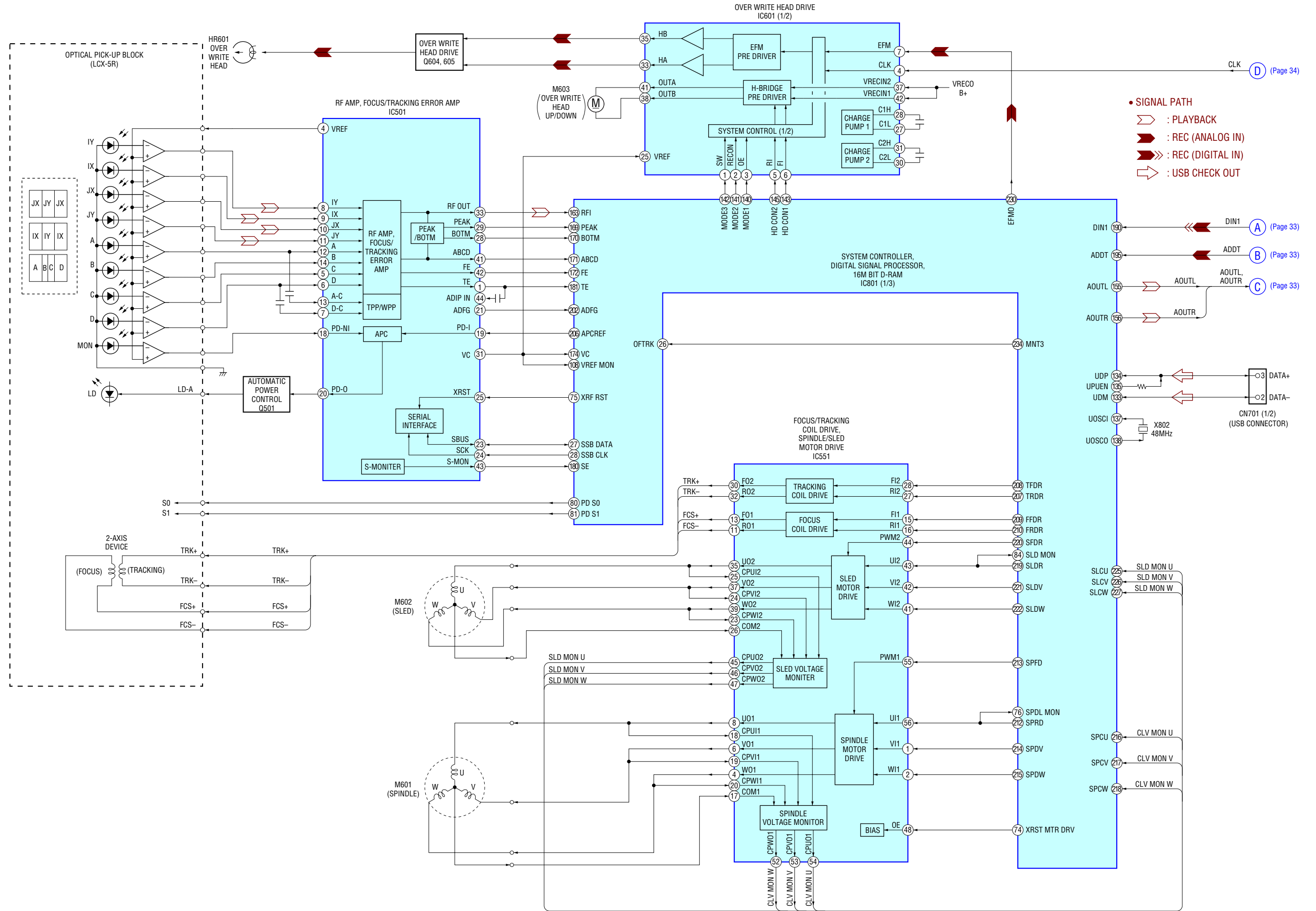

6-2. BLOCK DIAGRAM – AUDIO Section –

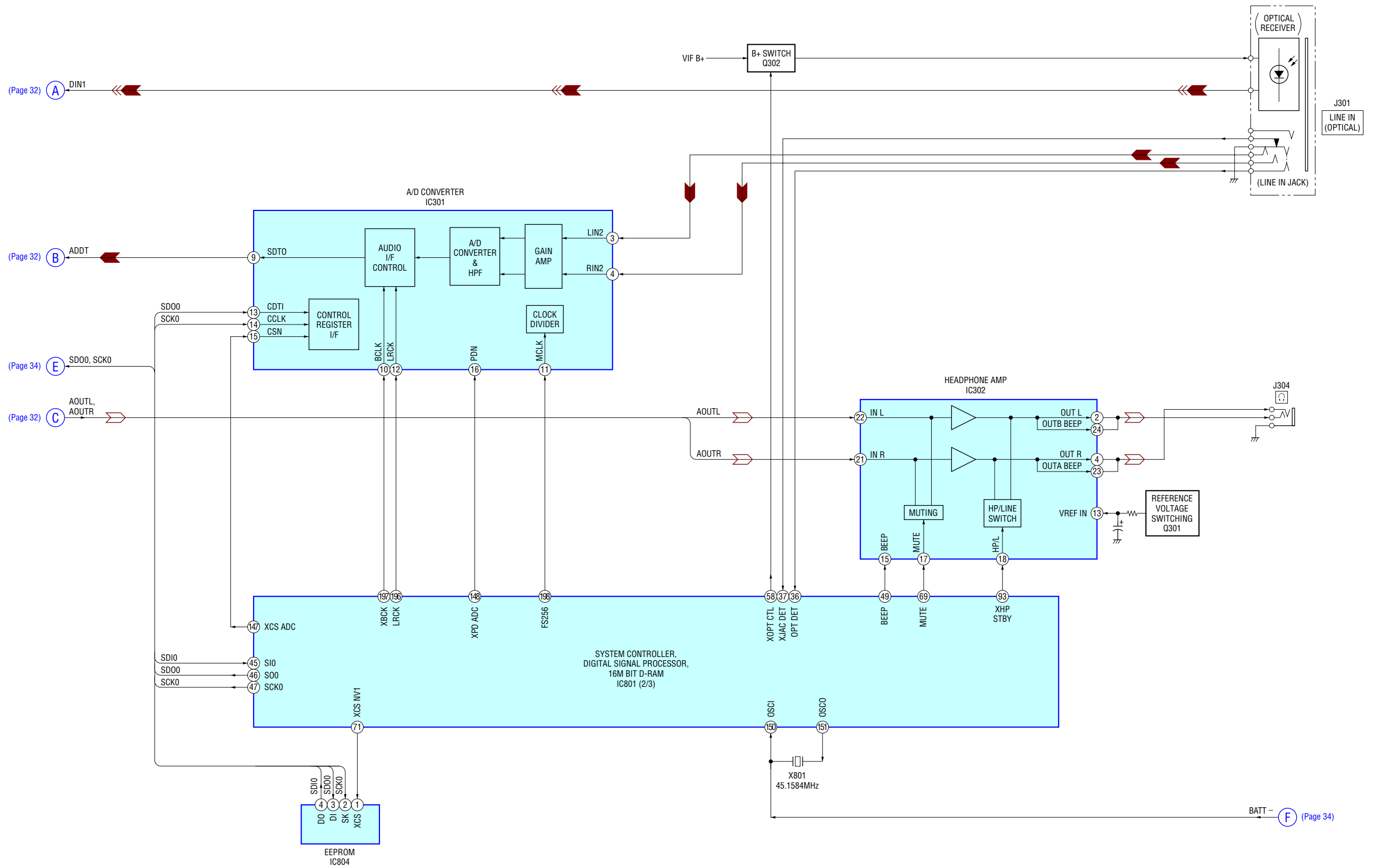

- SIGNAL PATH
- ◁ ▷ : PLAYBACK
- ▶ : REC (ANALOG IN)
- ▶▶ : REC (DIGITAL IN)

6-4. NOTE FOR PRINTED WIRING BOARD AND SCHEMATIC DIAGRAMS

Note on Printed Wiring Board:

- : parts extracted from the component side.
- : parts extracted from the conductor side.
- : Pattern from the side which enables seeing.
(The other layers' patterns are not indicated.)

Caution:
 Pattern face side: Parts on the pattern face side seen from the pattern face are indicated.
 (Conductor Side)
 Parts face side: Parts on the parts face side seen from the parts face are indicated.
 (Component Side)

- MAIN board is four-layer printed board. However, the patterns of layers 2 and 3 have not been included in this diagrams.
- Lead Layouts

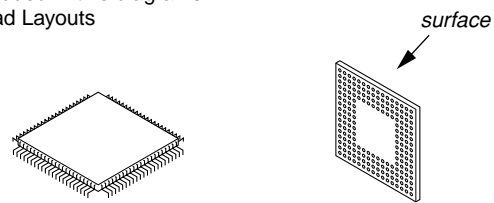

Lead layout of conventional IC CSP (chip size package)

Note on Schematic Diagram:

- All capacitors are in μF unless otherwise noted. pF : $\mu\mu\text{F}$ 50 WV or less are not indicated except for electrolytics and tantalums.
- All resistors are in Ω and $1/4\text{W}$ or less unless otherwise specified.
- % : indicates tolerance.
- : panel designation.

Note: The components identified by mark \triangle or dotted line with mark \triangle are critical for safety. Replace only with part number specified.

- : B+ Line.
- Total current is measured with MD installed.
- Power voltage is dc 3 V and fed with regulated dc power supply from DC IN 3 V jack (J601).
- Voltages and waveforms are dc with respect to ground in playback mode.
- no mark : PLAYBACK
- () : REC
- << >> : USB
- * : Impossible to measure
- Voltages are taken with a VOM (Input impedance 10 M Ω). Voltage variations may be noted due to normal production tolerances.
- Waveforms are taken with a oscilloscope. Voltage variations may be noted due to normal production tolerances.
- Circled numbers refer to waveforms.
- Signal path.
- ∑ : PLAYBACK
- ▶ : REC (ANALOG IN)
- ▶▶ : REC (DIGITAL IN)
- ◁ : USB CHECK OUT
- The voltage and waveform of CSP (chip size package) cannot be measured, because its lead layout is different form that of conventional IC.

6-5. PRINTED WIRING BOARD – MAIN Board (Component Side) –  :Uses unleaded solder.

• Semiconductor Location

Ref. No.	Location
D601	I-7
D606	I-3
D607	I-5
D608	H-3
D803	G-2
D804	H-2
D904	H-5
IC551	D-5
IC604	H-4
IC804	D-4
Q501	F-7
Q601	I-7
Q603	H-2
Q604	I-3
Q605	I-4
Q610	I-4

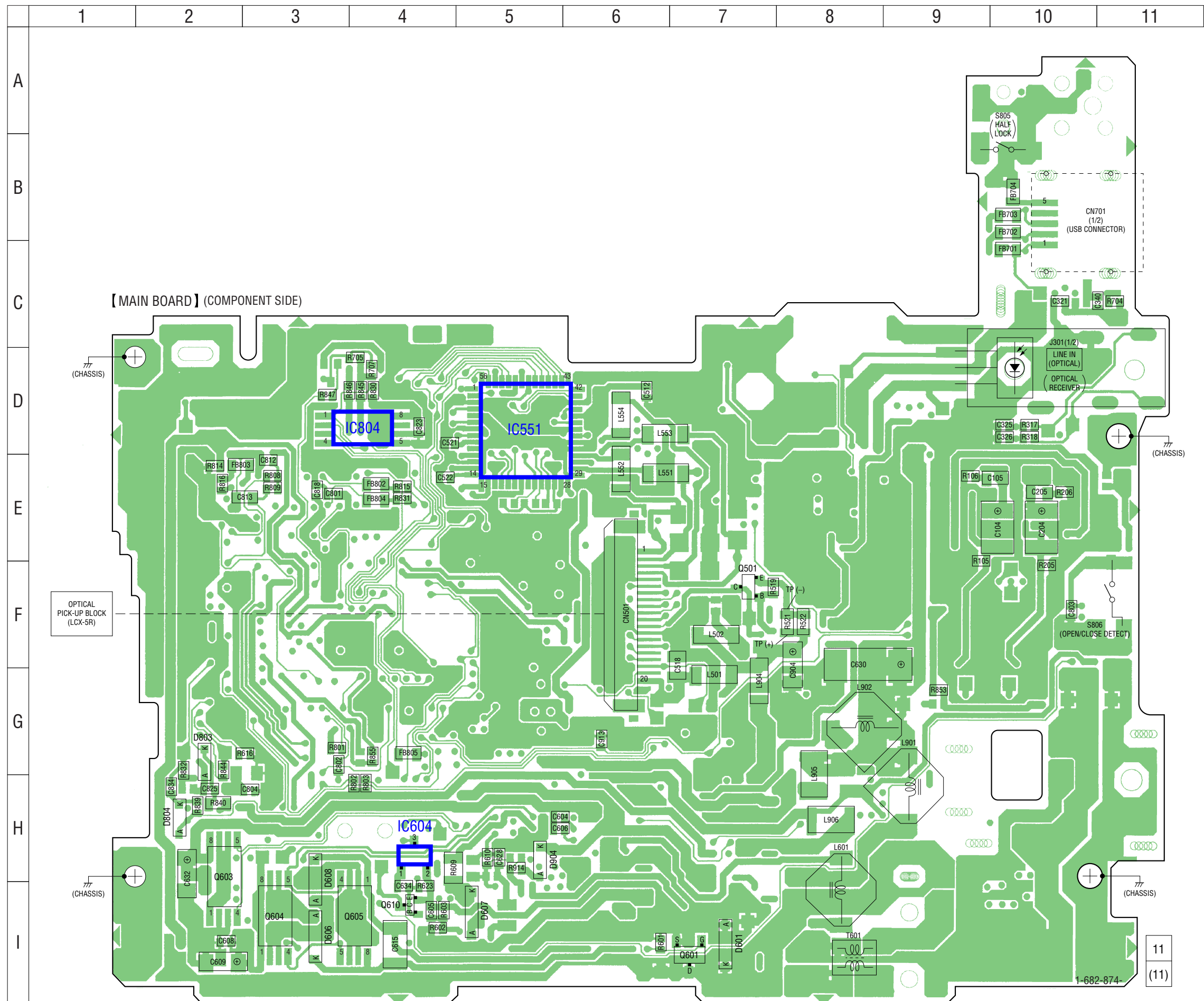

6-7. SCHEMATIC DIAGRAM – MAIN Board (1/4) – • See page 42 for Waveforms. • See page 43 for IC Block Diagrams.

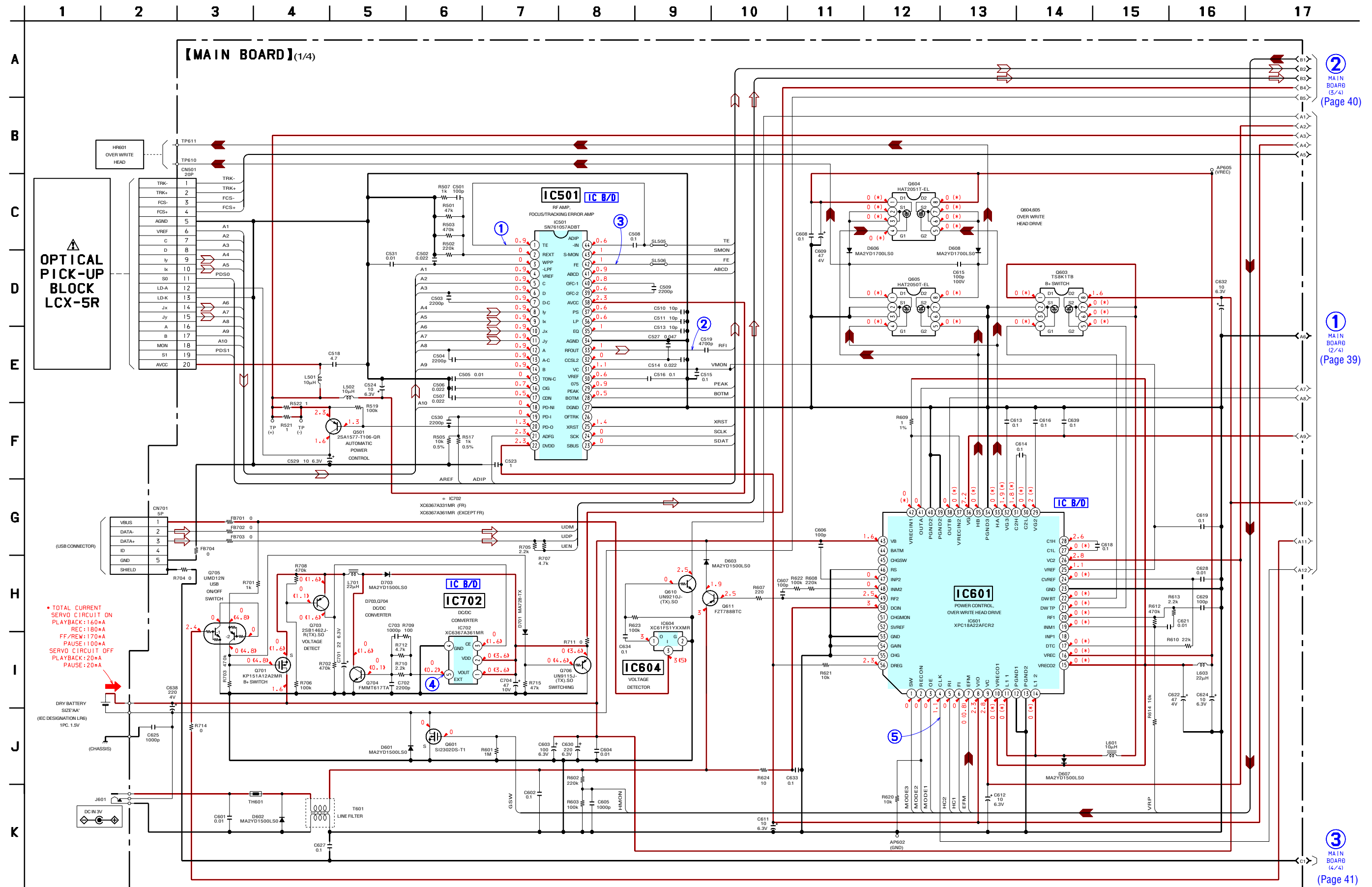

② MAIN BOARD (3/4) (Page 40)

① MAIN BOARD (2/4) (Page 39)

③ MAIN BOARD (4/4) (Page 41)

The components identified by mark Δ or dotted line with mark Δ are critical for safety. Replace only with part number specified.

Les composants identifiés par une marque Δ sont critiques pour la sécurité. Ne les remplacer que par une pièce portant le numéro spécifié.

6-9. SCHEMATIC DIAGRAM – MAIN Board (3/4) – • See page 42 for Waveforms.

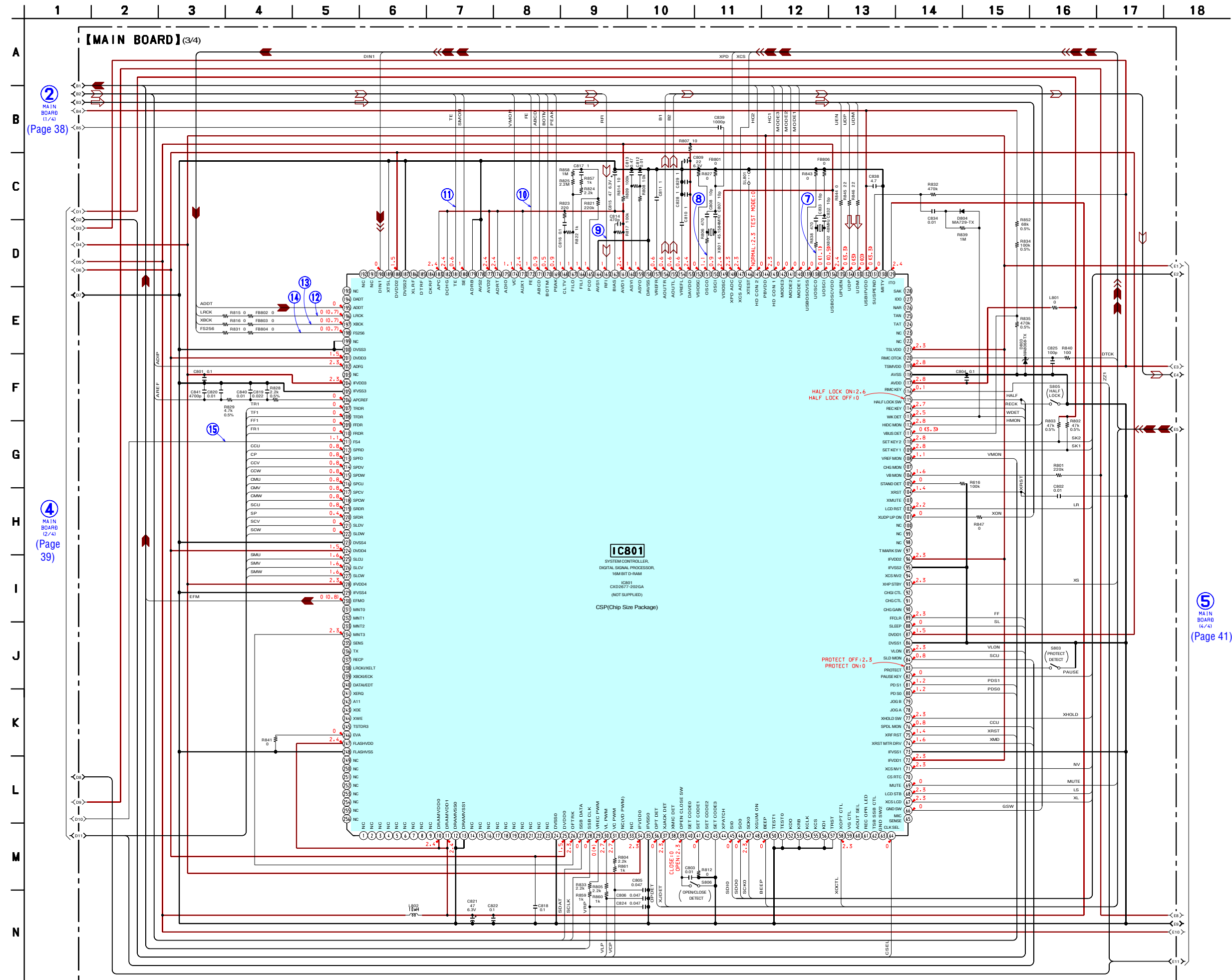

6-10. SCHEMATIC DIAGRAM – MAIN Board (4/4) – • See page 42 for Waveforms. • See page 43 for IC Block Diagrams.

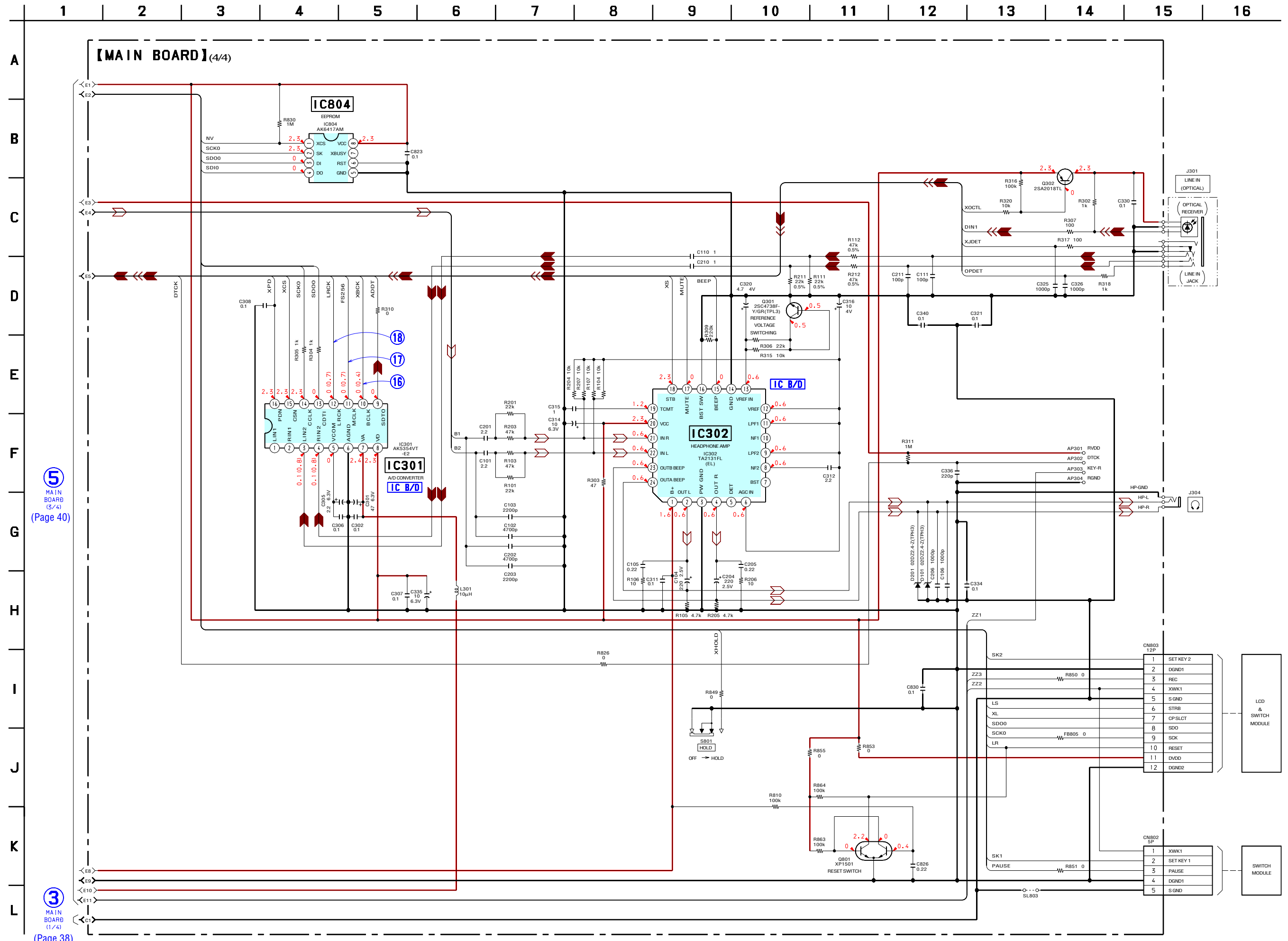

• Waveforms

1 IC501 ① (TE)

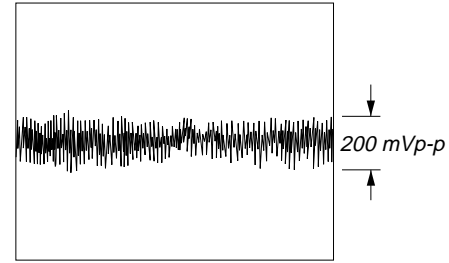

6 IC901 ⑤ (CLK)

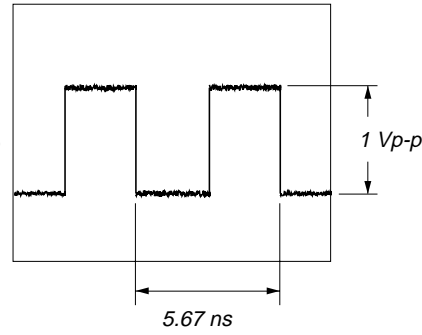

11 IC801 ⑩ (TE)

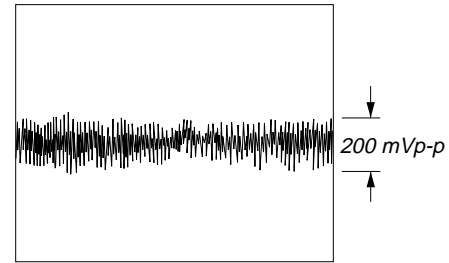

16 IC301 ⑩ (BCLK) (REC mode)

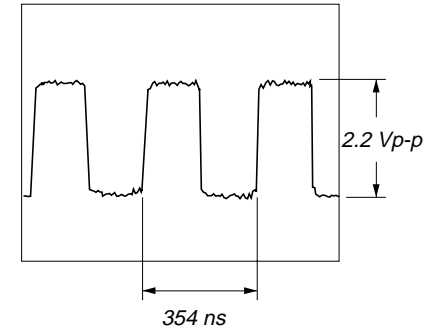

2 IC501 ③ (RF OUT)

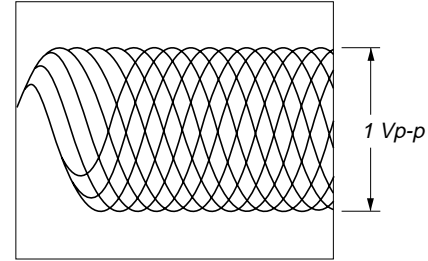

7 IC801 ⑩ (UOSCO) (USB mode)

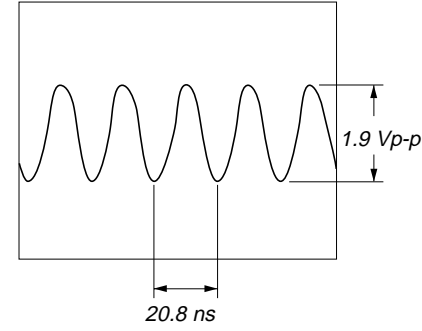

12 IC801 ⑩ (LRCK) (REC mode)

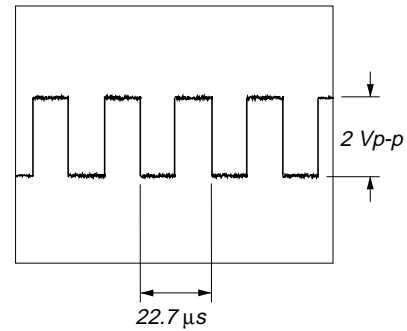

17 IC301 ⑩ (MCLK) (REC mode)

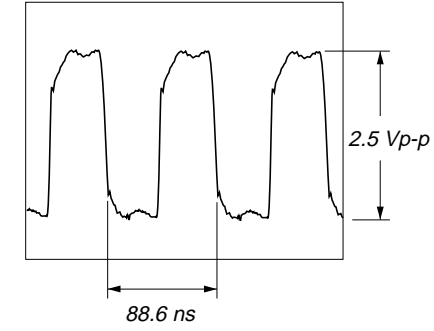

3 IC501 ④ (FE)

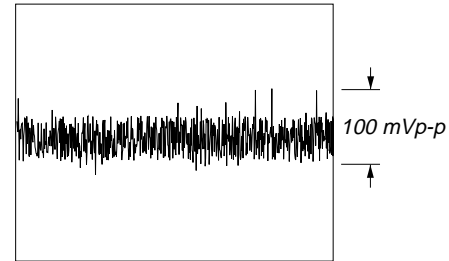

8 IC801 ⑩ (OSCO)

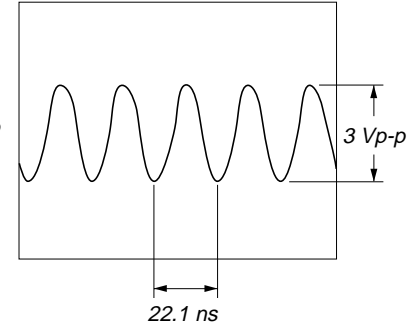

13 IC801 ⑩ (XBCK) (REC mode)

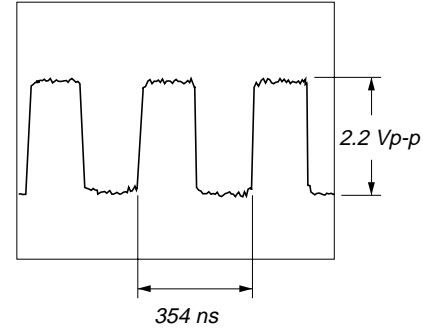

18 IC301 ⑩ (LRCK) (REC mode)

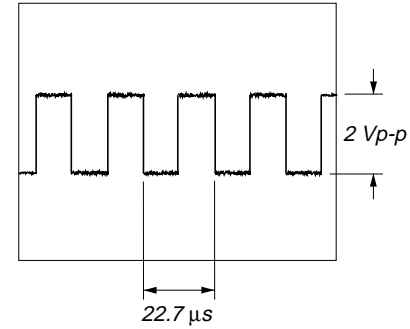

4 IC702 ⑤ (EXT) (USB mode)

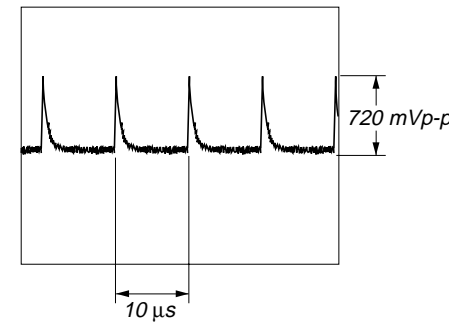

9 IC801 ⑩ (RFI)

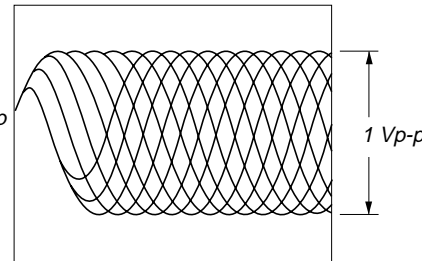

14 IC801 ⑩ (FS256) (REC mode)

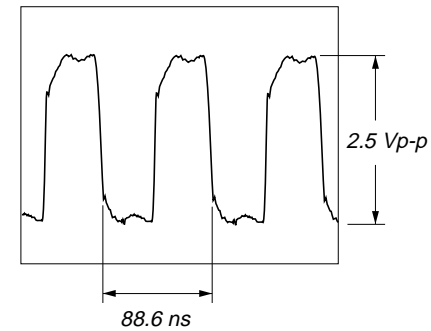

5 IC601 ④ (CLK)

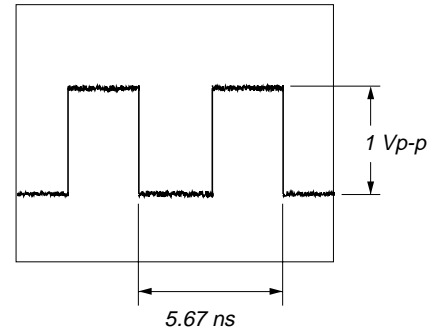

10 IC801 ⑩ (FE)

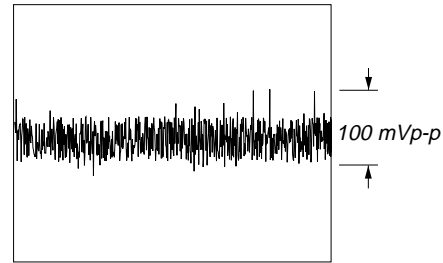

15 IC801 ⑩ (FS4)

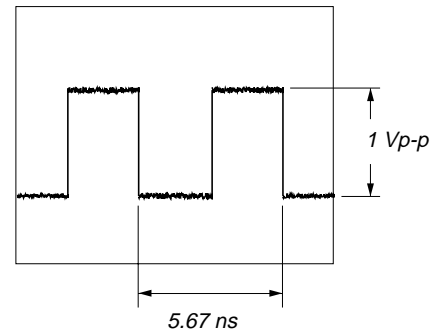

• IC Block Diagrams

IC301 AK5354VT-E2

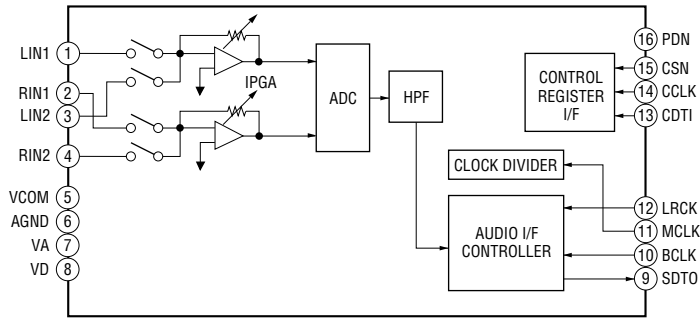

IC302 TA2131FL (EL)

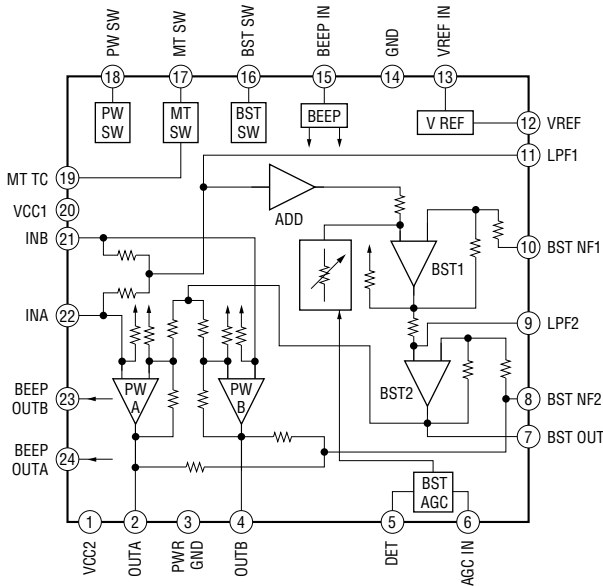

IC501 SN761057ADB

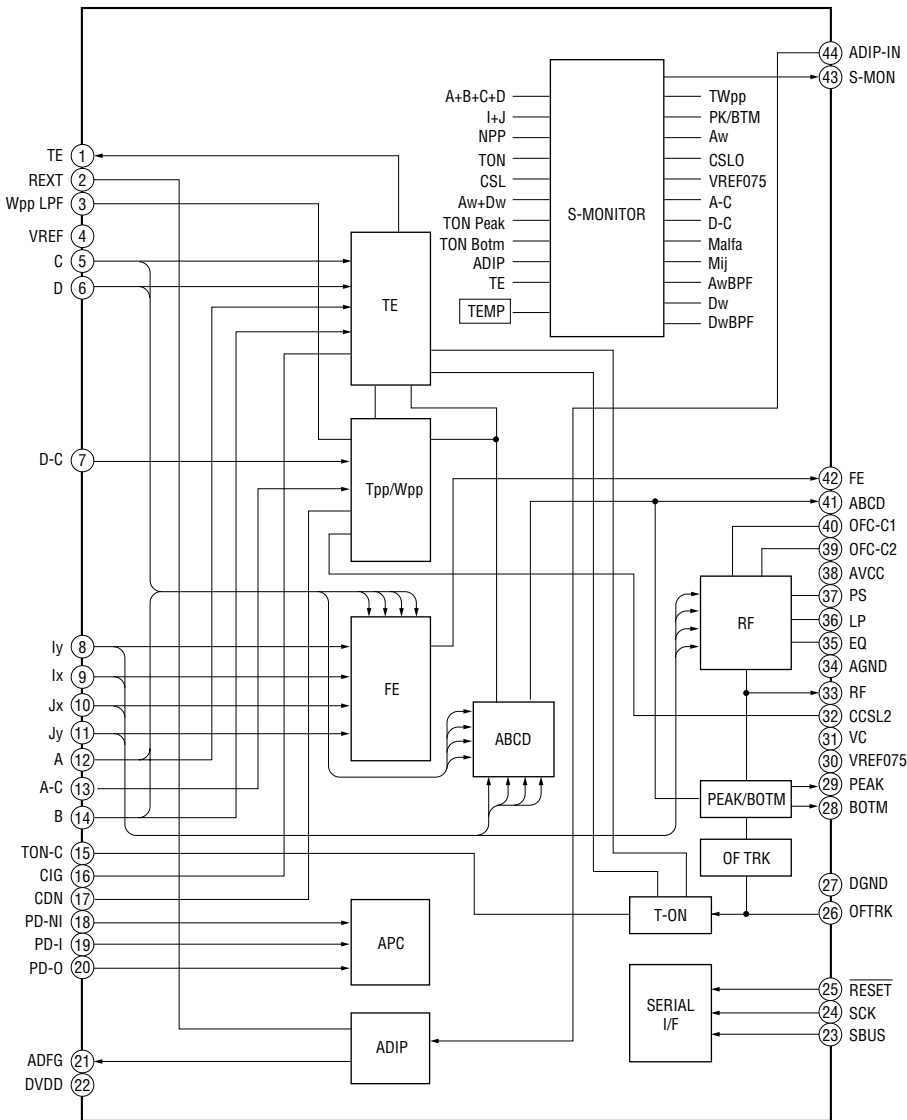

IC551 SC111258FCR2

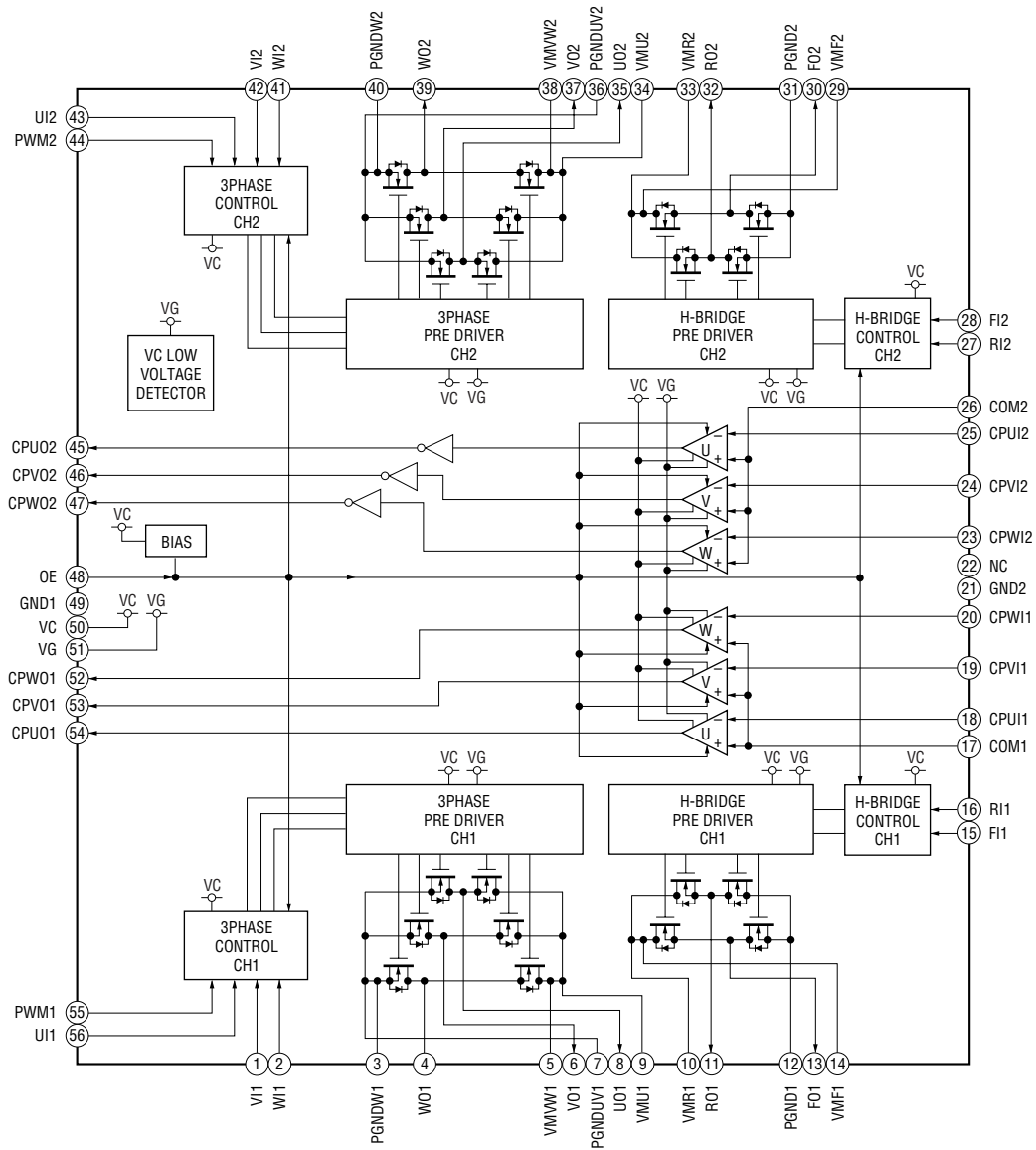

MZ-S1

IC601 XPC18A22AFCR2

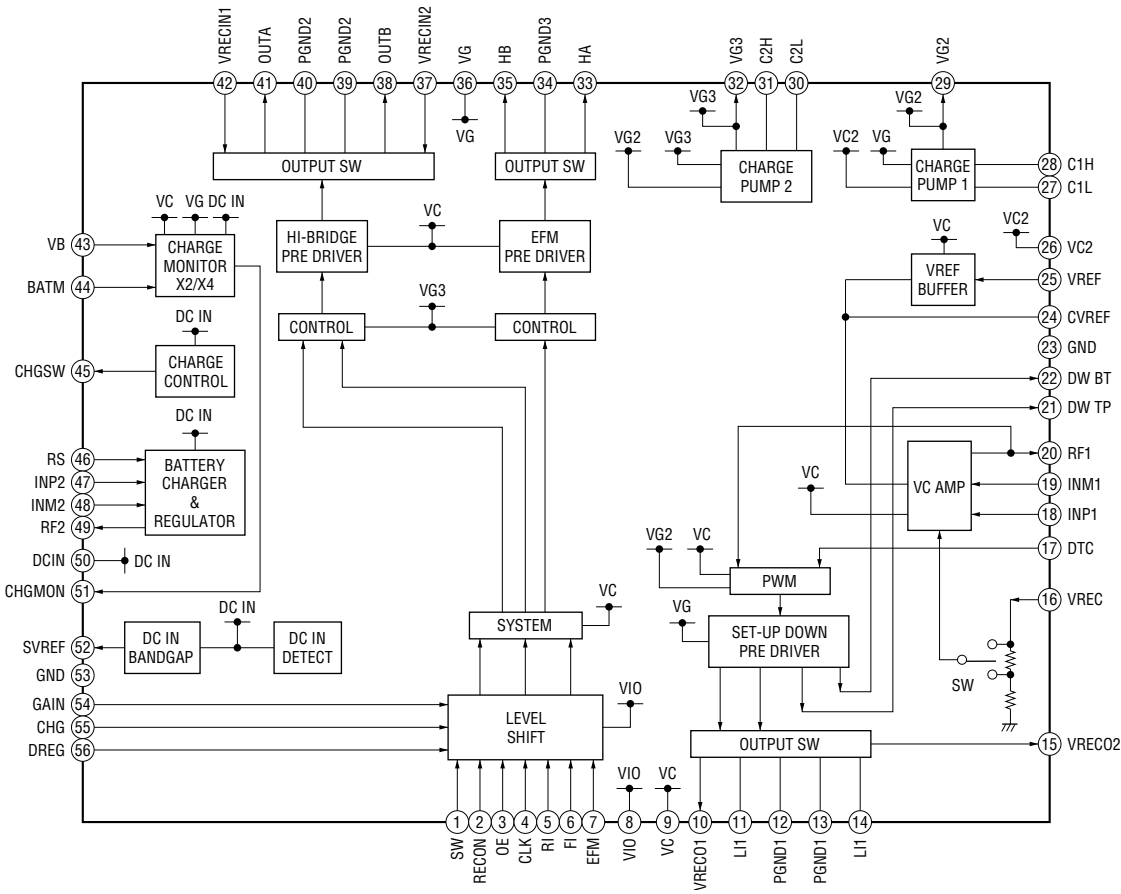

IC702 XC6367A361MR

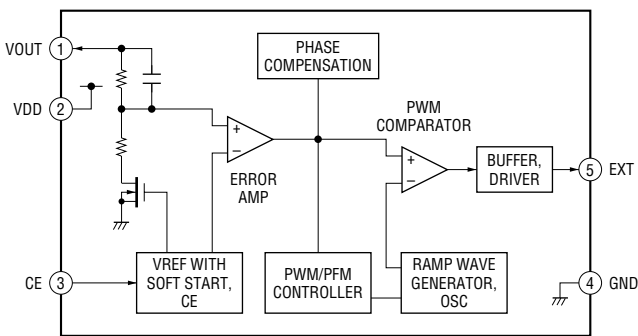

IC901 XPC18A32FCR2

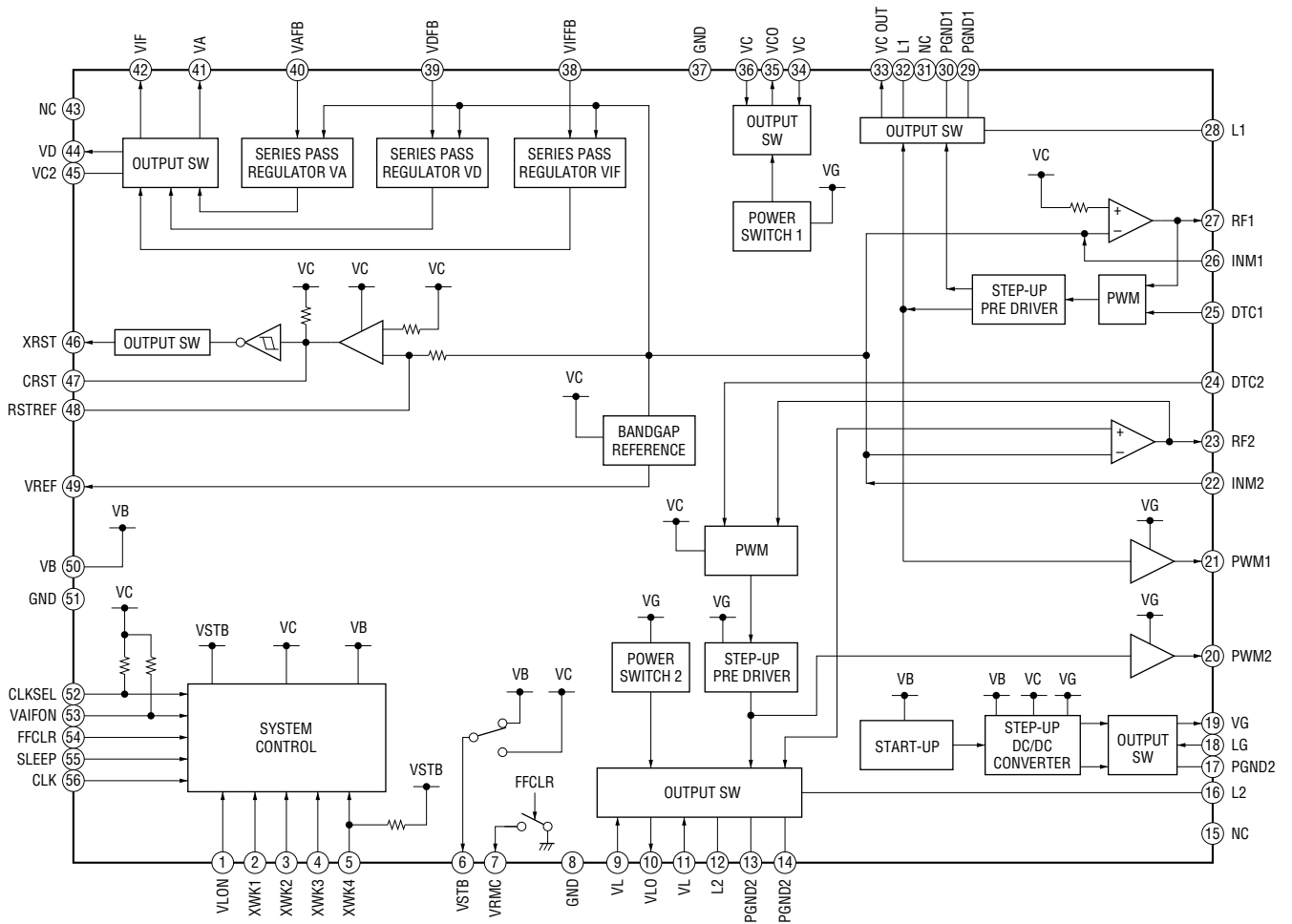

6-11. IC PIN FUNCTION DESCRIPTION

• IC501 SN761057DBT (RF AMP, FOCUS/TRACKING ERROR AMP)

Pin No.	Pin Name	I/O	Description
1	TE	O	Tracking error signal output to the system controller
2	REXT	—	Connect terminal to the external resistor for the ADIP amplifier control
3	WPP-LPF	—	Connect terminal to the external capacitor for the TPP/WPP low-pass filter
4	VREF	O	Reference voltage output terminal
5	C	I	Signal (C) input from the optical pickup detector
6	D	I	Signal (D) input from the optical pickup detector
7	D-C	I	Signal (D) input from the optical pickup detector (AC input)
8	IY	I	I-V converted RF signal (IY) input from the optical pickup detector
9	IX	I	I-V converted RF signal (IX) input from the optical pickup detector
10	JX	I	I-V converted RF signal (JX) input from the optical pickup detector
11	JY	I	I-V converted RF signal (JY) input from the optical pickup detector
12	A	I	Signal (A) input from the optical pickup detector
13	A-C	I	Signal (A) input from the optical pickup detector (AC input)
14	B	I	Signal (B) input from the optical pickup detector
15	TON-C	—	Connect terminal to the external capacitor for TON hold
16	CIG	—	Connect terminal to the external capacitor for the low-pass filter of NPP divider denominator
17	CDN	—	Connect terminal to the external capacitor for the low-pass filter of CSL divider denominator
18	PD-NI	I	Light amount monitor input terminal (non-invert input)
19	PD-I	I	Reference PWM signal input for the laser automatic power control from the system controller
20	PD-O	O	Light amount monitor output terminal
21	ADFG	O	ADIP duplex FM signal (22.05kHz \pm 1kHz) output to the system controller
22	DVDD	—	Power supply terminal (+2.3V) (digital system)
23	SBUS	I/O	SSB serial data input/output with the system controller
24	SCK	I	SSB serial clock signal input from the system controller
25	XRST	I	Reset signal input from the system controller "L": reset
26	OFTRK	I	Off track signal input terminal Not used
27	DGND	—	Ground terminal (digital system)
28	BOTM	O	Bottom hold signal output of the light amount signal (RF/ABCD) to the system controller
29	PEAK	O	Peak hold signal output of the light amount signal (RF/ABCD) to the system controller
30	VREF075	—	Connect terminal to the external capacitor for the internal reference voltage
31	VC	O	Middle point voltage (+1.2V) generation output terminal
32	CCSL2	—	Connect terminal to the external capacitor for the TPP/WPP low-pass filter
33	RF OUT	O	Playback EFM RF signal output to the system controller
34	AGND	—	Ground terminal (analog system)
35 to 37	EQ, LP, PS	—	Connect terminal to the external capacitor for the RF equalizer
38	AVCC	—	Power supply terminal (+2.3V) (analog system)
39, 40	OFC-2, OFC-1	—	Connect terminal to the external capacitor for the RF AC coupling
41	ABCD	O	Light amount signal (ABCD) output to the system controller
42	FE	O	Focus error signal output to the system controller
43	S-MON	O	Servo signal monitor output to the system controller
44	ADIP-IN	I	ADIP duplex FM signal (22.05kHz \pm 1kHz) input terminal Not used

• IC801 CXD2677-202GA (SYSTEM CONTROLLER, DIGITAL SIGNAL PROCESSOR, 16M BIT D-RAM)

Pin No.	Pin Name	I/O	Description
1	NC	O	Load address strobe signal output terminal for D-RAM Not used
2	NC	I	Test input terminal for D-RAM Not used
3 to 7	NC	O	Address signal output terminal for D-RAM Not used
8, 9	NC	I/O	Two-way data bus terminal for D-RAM Not used
10, 11	DRAMVDD0, 1	—	Power supply terminal (for D-RAM) (+2.4V)
12, 13	DRAMVSS0, 1	—	Ground terminal (for D-RAM)
14, 15	NC	I/O	Two-way data bus terminal for D-RAM Not used
16 to 19	NC	O	Address signal output terminal for D-RAM Not used
20	NC	O	Column address strobe signal output terminal for D-RAM Not used
21	NC	I	Test input terminal for D-RAM Not used
22, 23	NC	O	Address signal output terminal for D-RAM Not used
24	DVSS0	—	Ground terminal (for the DSP block)
25	DVDD0	—	Power supply terminal (for the DSP block) (+1.5V)
26	OFTRK	I	Off track signal input from the DSP monitor (3)
27	SSB DATA	I/O	SSB data input/output with the RF amplifier
28	SSB CLK	O	SSB clock output to the RF amplifier
29	VREC PWM	O	PWM signal output for the Over write head drive power supply voltage control to the power control
30	VL PWM	O	PWM signal output for the laser power supply voltage control to the power control
31	VC PWM	O	PWM signal output for the system power supply voltage control to the power control
32	NC (VD PWM)	O	VD power supply voltage control signal output terminal Not used
33	NC	—	Not used
34	IFVDD0	—	Power supply terminal (for the microcomputer I/F block) (+2.3V)
35	IFVSS0	—	Ground terminal (for the microcomputer I/F block)
36	OPT DET	I	DIN plug detection signal input terminal “H”: DIN plug
37	XJACK DET	I	LINE IN plug detection signal input terminal “L”: LINE or OPT plug
38	XMIC DET	I	Microphone plug detection signal input terminal “L”: microphone plug Not used
39	OPEN CLOSE SW	I	Open/close detection switch of the upper panel input terminal “L”: when upper panel close
40	SET CODE0	I	Input terminal for the set (open in this set)
41	SET CODE1	I	Input terminal for the set (fixed at “L” in this set)
42	SET CODE2	I	Input terminal for the set (open in this set)
43	SET CODE3	I	Input terminal for the set (fixed at “L” in this set)
44	XPATCH	I	Patch function detection signal input terminal “L”: patch function Not used
45	SI0	I	Serial data input from the nonvolatile memory
46	SO0	O	Serial data output to the nonvolatile memory, A/D converter and liquid crystal display element module
47	SCK0	O	Serial clock signal output to the nonvolatile memory, A/D converter and liquid crystal display element module
48	XGUM ON	I	Rechargeable battery detection switch input terminal “L”: there is rechargeable battery Not used
49	BEEP	O	Beep sound control signal output to the headphone amplifier
50, 51	TEST1, TEST0	I	Input terminal for the main test (normally fixed at “L”)
52	KDO	O	Data output terminal Not used
53	KRB	I	Ready/busy signal input terminal Not used
54	KCLK	O	Clock signal output terminal Not used

Pin No.	Pin Name	I/O	Description
55	KCS	O	Chip select signal output terminal Not used
56	KDI	I	Data input terminal Not used
57	TRST	I	Input terminal for the test mode set (normally fixed at "L")
58	XOPT CTL	O	Power supply ON/OFF control signal output for the DIN PD drive
59	VG CTL	O	VG power supply voltage control signal output terminal Not used
60	AOUT SEL	O	HP/LINE changeover signal output terminal Not used
61	REC OPR LED	O	LED ON/OFF control signal output terminal Not used
62	TSB SSB CTL	O	TSB/SSB changeover control signal output Not used
63	GND SW2	O	Battery for Cradle ON/OFF switch control signal output terminal Not used
64	CLK SEL	O	System clock select signal output to the power control
65	MIC SENSE	O	Mic sensitivity control signal output to the mic amplifier "L": Low sensitivity "H": High sensitivity (normally: "H") Not used
66	GND SW	O	GND changeover control signal output terminal
67	XCS LCD	O	Chip select signal output to the liquid crystal display element module
68	LCD STB	O	Strobe signal output to the liquid crystal display element module
69	MUTE	O	Analog muting control signal output for the headphone amplifier "H": muting ON
70	CS RTC	O	Chip select signal output terminal Not used
71	XCS NV1	O	Chip select signal (1) output to the nonvolatile memory
72	IFVDD1	—	Power supply terminal (for the microcomputer I/F block) (+2.3V)
73	IFVSS1	—	Ground terminal (for the microcomputer I/F block)
74	XRST MTR DRV	O	Reset control signal output to the motor driver "L": reset
75	XRF RST	O	Reset control signal output to the RF amplifier "L": reset
76	SPDL MON	I	Spindle servo monitor signal input terminal
77	XHOLD SW	I	HOLD switch input terminal "L": hold ON
78, 79	JOG A, B	I	Jog dial pulse input terminal Not used
80, 81	PD S0, PD S1	O	PD IC mode changeover signal output to the optical pick up
82	PAUSE KEY	I	Pause key input terminal from the switch module
83	PROTECT	I	Detection input terminal of the record check claw from the protect detection switch "H": protect
84	SLD MON	I	Sled servo monitor signal input terminal
85	VLON	O	Power supply control signal output for the laser diode drive to the power control
86	DVSS1	—	Ground terminal (for the DSP block)
87	DVDD1	—	Power supply terminal (for the DSP block) (+1.5V)
88	SLEEP	O	System sleep control signal output to the power control "H": sleep ON
89	FFCLR	O	Input latch output for the start switching to the power control
90	CHG GAIN	O	Charge gain control signal output terminal Not used
91	CHG CTL	O	Charge ON/OFF control signal output terminal "H": charge ON Not used
92	CHGI CTL	O	Charge current control signal output terminal Not used
93	XHP STBY	O	Power supply control signal output for the head phone
94	XCS NV2	O	Chip select signal (2) output terminal Not used
95	IFVSS2	—	Ground terminal (for the microcomputer I/F block)
96	IFVDD2	—	Power supply terminal (for the microcomputer I/F block) (+2.3V)
97	T MARK SW	I	T MARK (track mark) switch input terminal "L": track mark detection Not used
98	NC	O	LED ON/OFF control signal output terminal for CHG (charge display) Not used
99	NC	I	Initial switch detection input terminal Not used
100	NC	—	Not used
101	XUDP UP ON	O	Pullup resistor changeover control signal output terminal Not used

Pin No.	Pin Name	I/O	Description
102	LCD RST	O	Reset control signal output to the liquid crystal display element module "L": reset
103	XMUTE	O	Analog muting control signal output terminal "L": muting ON Not used
104	XRST	I	System reset signal input from the power control "L": reset
105	STAND DET	I	Charging stand detection signal input terminal Not used
106	VB MON	I	Voltage monitor input terminal (A/D input) of the UNREG power supply
107	CHG MON	I	Charge voltage monitor input terminal (A/D input) Not used
108	VREF MON	I	Clear reference voltage monitor input terminal (A/D input) from the RF amplifier
109, 110	SET KEY 1, 2	I	Key input terminal (A/D input) from the switch & liquid crystal display element module
111	VBUS DET	I	USB power supply voltage detection signal input terminal
112	HIDC MON	I	HIGH DC voltage monitor input terminal (A/D input)
113	WK DET	I	Set key and USB start switching detection signal input terminal (A/D input)
114	REC KEY	I	REC key input terminal (A/D input)
115	HALF LOCK SW	I	OPEN switch detection switch input terminal (A/D input) Input "L" when the open button is pressed. Input "H" in other cases.
116	RMC KEY	I	Key input terminal (A/D input) from the remote commander attached headphone Not used
117	AVDD	—	Power supply terminal (for the microcomputer analog) (+2.8V)
118	AVSS	—	Ground terminal (for the microcomputer analog)
119	TSMVDD	—	Power supply terminal (for the TSB master communication) (+2.8V)
120	RMC DTCK	I/O	Serial data input/output with the remote commander attached headphone Not used
121	TSLVDD	—	Power supply terminal (for the I/F to TSB slave) (+2.3V)
122, 123	NC	—	Not used
124	TAT	—	Not used
125	TAN	—	Not used
126	NAR	—	Not used
127	ID0	—	Not used
128	SAK	—	Not used
129	IT0	—	Not used
130	MITY	—	Ground terminal Not used
131	SUSPEND	O	USB suspend signal output terminal
132	USBIFVDD	—	Power supply terminal (for USB I/F) (+3.6V)
133	UDM	I	USB data (-) input terminal
134	UDP	I	USB data (+) input terminal
135	UPUEN	O	USB pullup resistor connection control output terminal
136	USBOSCVD	—	Power supply terminal (for the USB oscillation circuit) (+2.4V)
137	UOSCI	I	Clock (48MHz) input terminal for the USB
138	UOSCO	O	Clock (48MHz) output terminal for the USB
139	USBOSCVSS	—	Ground terminal (for the USB oscillation circuit)
140 to 142	MODE1 to 3	O	Power supply control signal output for the over write head to the over write head drive
143	HD CON 1	O	Over write head control signal output to the over write head drive
144	PBVDD	—	Power supply terminal (+2.3V)
145	HD CON 2	O	Over write head control signal output to the over write head drive
146	XTEST	I	Input terminal for test mode set (normally: open) "L": test mode
147	XCS ADC	O	Chip select signal output to the A/D converter
148	XPD ADC	O	Power supply control signal output for the drive to the A/D converter
149	VDIOSC	—	Power supply terminal (for the OSC cell) (+2.4V)
150	OSCI	I	System clock (45.1584MHz) input terminal

Pin No.	Pin Name	I/O	Description
151	OSCO	O	System clock (45.1584MHz) output terminal
152	VSIOSC	—	Ground terminal (for the OSC cell)
153	DAVDD	—	Power supply terminal (for the built-in D/A converter) (+2.4V)
154	VREFL	I	Reference voltage input terminal (for the built-in D/A converter L-CH)
155	AOUTL	O	Built-in D/A converter (L-CH) output terminal
156	AOUTR	O	Built-in D/A converter (R-CH) output terminal
157	VREFR	I	Reference voltage input terminal (for the built-in D/A converter R-CH)
158	DAVSS	—	Ground terminal (for the built-in D/A converter)
159	ASYO	O	Playback EFM duplex signal output terminal
160	ASYI	I	Playback EFM comparison slice level input terminal
161	AVD1	—	Power supply terminal (for the DSP asymmetry system analog) (+2.4V)
162	BIAS	I	Bias current input terminal for the playback EFM comparison
163	RFI	I	Playback EFM the RF signal input from the RF amplifier
164	AVS1	—	Ground terminal (for the DSP asymmetry system analog)
165	PCO	O	Phase comparison output terminal for the playback EFM system master PLL
166	FILI	I	Filter input terminal for the playback EFM system master PLL
167	FILO	O	Filter output terminal for the playback EFM system master PLL
168	CLTV	I	Internal VCO control voltage input terminal for the playback EFM system master PLL
169	PEAK	I	Peak hold signal input of the light amount signal (RF/ABCD) from the RF amplifier
170	BOTM	I	Bottom hold signal input of the light amount signal (RF/ABCD) from the RF amplifier
171	ABCD	I	Light amount signal (ABCD) input from the RF amplifier
172	FE	I	Focus error signal input from the Focus error amplifier
173	AUX1	I	Support signal (I ₃ signal/temperature signal) input terminal (A/D input)
174	VC	I	Middle point voltage (+1.1V) input terminal
175	ADIO	O	Monitor output terminal of A/D converter input signal Not used
176	ADRT	I	A/D converter the upper limit voltage input terminal (fixed at “H” in this set)
177	AVD2	—	Power supply terminal (for the DSP servo analog system) (+2.4V)
178	AVS2	—	Ground terminal (for the DSP servo analog system)
179	ADRB	I	A/D converter the lower limit voltage input terminal (fixed at “L” in this set)
180	SE	I	Servo signal monitor input terminal (A/D input) from the RF amplifier
181	TE	I	Tracking error signal input from the Tracking error amplifier
182	DCHG	—	Connecting terminal with the analog power supply of the low impedance (fixed at “H” in this set)
183	APC	I	Error signal input for the laser automatic power control (fixed at “H” in this set)
184	CKRF	O	Clock output terminal for the RF amplifier control Not used
185	DTRF	O	Data output terminal for the RF amplifier control Not used
186	XLRF	O	Latch signal output terminal for the RF amplifier control Not used
187	DVSS2	—	Ground terminal (for the DSP block)
188	DVDD2	—	Power supply terminal (for the DSP block) (+1.5V)
189	XTSL	I	Input terminal for the frequency set up of the system clock “L”: 45.1584MHz, “H”: 22.5792MHz (fixed at “L” in this set)
190	DIN1	I	Input terminal of the record system digital audio signal
191 to 193	NC	O	D/A converter PWM signal output terminal Not used
194	DADT	O	Audio data output terminal Not used
195	ADDT	I	Data input from the external A/D converter
196	LRCK	O	L/R sampling clock signal (44.1KHz) output to the external A/D converter
197	XBCK	O	Bit clock signal (2.8224MHz) output to the external A/D converter

Pin No.	Pin Name	I/O	Description
198	FS256	O	11.2896MHz clock signal output to the external A/D converter
199	NC	I	Ground terminal Clock signal input from the external VCO Not used
200	DVSS3	—	Ground terminal (for the DSP block)
201	DVDD3	—	Power supply terminal (for the DSP block) (+1.5V)
202	ADFG	I	ADIP duplex FM signal (20.05±1kHz) input from the RF amplifier
203	NC	O	Filter cut off control signal output terminal Not used
204	IFVDD3	—	Power supply terminal (for the microcomputer I/F block) (+2.3V)
205	IFVSS3	—	Ground terminal (for the microcomputer I/F block)
206	APCREF	O	Reference PWM signal output for the laser automatic power control to the RF amplifier
207	TRDR	O	Tracking servo drive PWM signal output (-) to the coil driver
208	TFDR	O	Tracking servo drive PWM signal output (+) to the coil driver
209	FFDR	O	Focus servo drive PWM signal output (+) to the coil driver
210	FRDR	O	Focus servo drive PWM signal output (-) to the coil driver
211	FS4	O	176.4kHz clock signal output to the power control
212	SPRD	O	Spindle motor drive control signal output (U) to the motor driver
213	SPFD	O	Spindle servo drive PWM signal output to the motor driver
214	SPDV	O	Spindle motor drive control signal output (V) to the motor driver
215	SPDW	O	Spindle motor drive control signal output (W) to the motor driver
216	SPCU	I	Spindle motor drive comparison signal input (U) from the motor driver
217	SPCV	I	Spindle motor drive comparison signal input (V) from the motor driver
218	SPCW	I	Spindle motor drive comparison signal input (W) from the motor driver
219	SRDR	O	Sled motor drive control signal output (U) to the motor driver
220	SFDR	O	Sled servo drive PWM signal output to the motor driver
221	SLDV	O	Sled motor drive control signal output (V) to the motor driver
222	SLDW	O	Sled motor drive control signal output (W) to the motor driver
223	DVSS4	—	Ground terminal (for the DSP block)
224	DVDD4	—	Power supply terminal (for the DSP block) (+1.5V)
225	SLCU	I	Sled motor drive comparison signal input (U) from the motor driver
226	SLCV	I	Sled motor drive comparison signal input (V) from the motor driver
227	SLCW	I	Sled motor drive comparison signal input (W) from the motor driver
228	IFVDD4	—	Power supply terminal (for the microcomputer I/F block) (+2.3V)
229	IFVSS4	—	Ground terminal (for the microcomputer I/F block)
230	EFMO	O	EFM encode data output for the record to the over write head drive
231 to 233	MNT0 to 2	O	DSP monitor (0) to (2) output terminal Not used
234	MNT3	O	Off track signal output from the DSP monitor (3)
235	SENSE	O	DSP internal status (DSP SENS monitor) signal output terminal Not used
236	TX	O	Record data output enable signal output monitor terminal of the DSP Not used
237	RECP	O	Laser power changeover signal output terminal Not used
238	LRCKI/XELT	I	Input terminal for the PCM data I/F/ ATRAC data I/F Not used
239	XBACKI/ECK	I	Input terminal for the PCM data I/F/ ATRAC data I/F Not used
240	DATAI/EDT	I	Input terminal for the PCM data I/F/ ATRAC data I/F Not used
241	XERQ	I	Input terminal for the ATRAC data I/F Not used
242	A11	O	Address signal output terminal for D-RAM Not used
243	XOE	O	Output enable signal output terminal for D-RAM Not used
244	XWE	O	Data write enable signal output terminal for D-RAM Not used
245	TSTDR3	I	Test input terminal for D-RAM Not used

MZ-S1

Pin No.	Pin Name	I/O	Description
246	EVA	I	EVA/FLASH chip discrimination input terminal “L”: FLASH chip, “H”: EVA chip (fixed at “L” in this set)
247	FLASHVDD	—	Power supply terminal (for the built-in flash memory) (+2.4V)
248	FLASHVSS	—	Ground terminal (for the built-in flash memory)
249 to 256	NC	—	Not used

7-2. CHASSIS SECTION

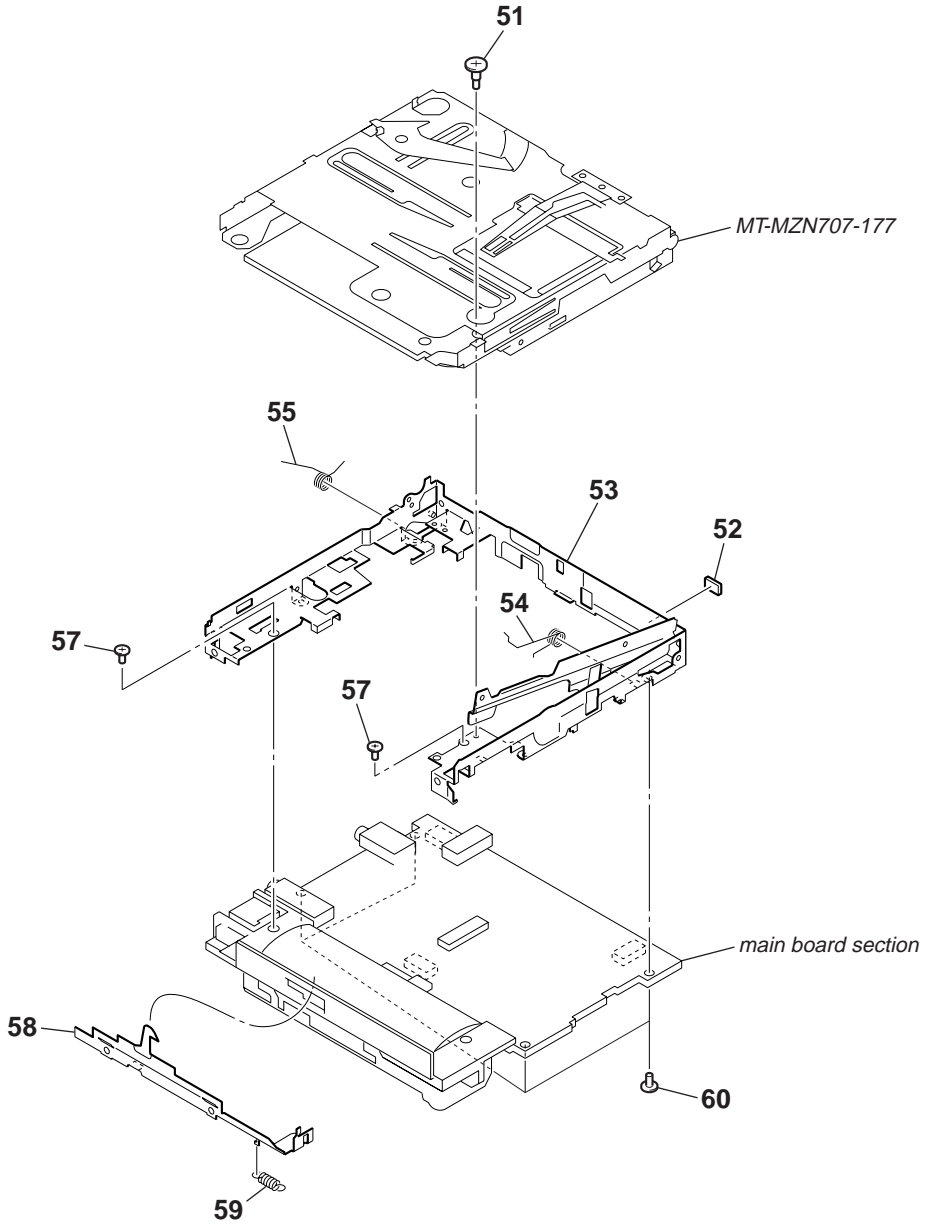

Ref. No.	Part No.	Description	Remark	Ref. No.	Part No.	Description	Remark
51	3-237-072-01	SCREW (MD), STEP		57	3-318-382-91	SCREW (1.7X2.5), TAPPING	
52	3-243-697-01	SPACER (CHASSIS)		58	3-238-514-01	SLIDER, OPEN	
53	X-3381-604-1	CHASSIS ASSY, SET		59	3-240-892-01	SPRING (LOCK), COMPRESSION	
54	3-238-490-01	SPRING (R), TORSION		60	3-335-797-01	SCREW (M1.4X2), TOOTHED LOCK	
55	3-238-481-01	SPRING (L), TORSION					

7-3. MAIN BOARD SECTION

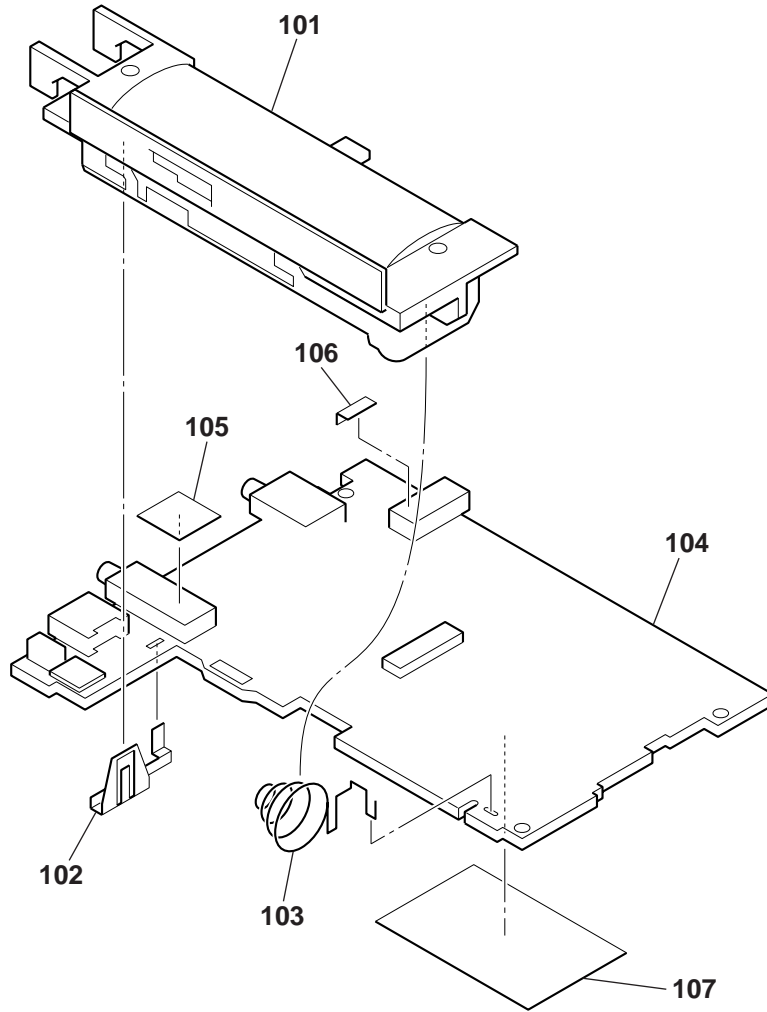

Ref. No.	Part No.	Description	Remark	Ref. No.	Part No.	Description	Remark
101	3-237-079-01	CASE, BATTERY		105	3-242-558-01	SPACER (LINE IN)	
102	3-237-073-01	TERMINAL BOARD (+), BATTERY		106	3-242-557-01	SPACER (DC IN)	
103	3-237-074-01	TERMINAL (-), BATTERY		107	3-242-559-01	SHEET (WIRE)	
104	A-3021-764-B	MAIN BOARD, COMPLETE (FOR SERVICE)					

7-4. CASE (LOWER) SECTION-1

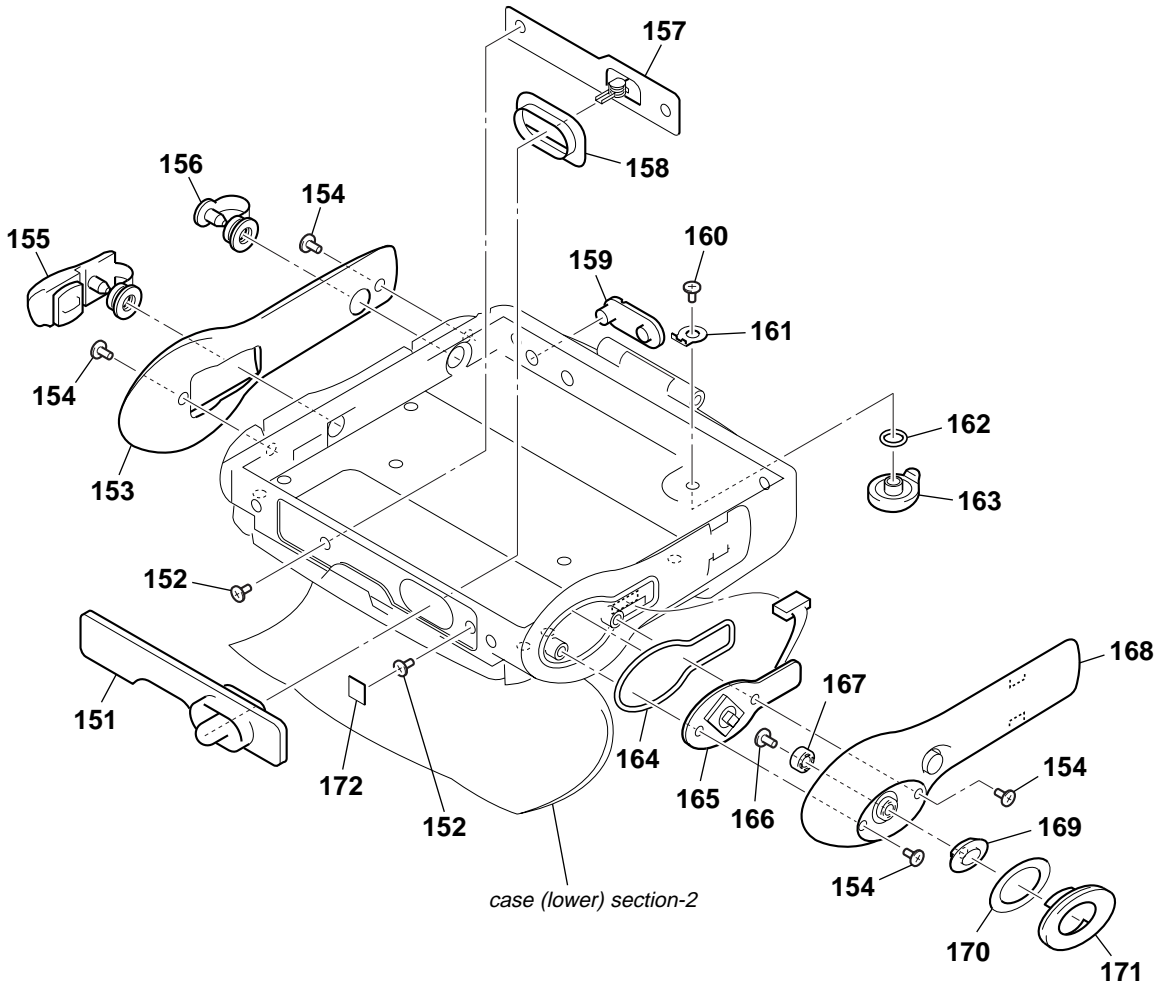

<u>Ref. No.</u>	<u>Part No.</u>	<u>Description</u>	<u>Remark</u>	<u>Ref. No.</u>	<u>Part No.</u>	<u>Description</u>	<u>Remark</u>
151	3-238-506-01	KNOB (OPEN)		162	3-238-520-01	RING, O	
152	3-225-873-29	SCREW (M1.4)		163	3-238-504-01	KNOB (HOLD)	
153	3-238-507-01	ORNAMENT (L)		164	3-238-510-01	PACKING (SW)	
154	4-984-017-21	SCREW (1.7), TAPPING		165	1-476-938-11	SWITCH UNIT	
155	3-238-508-01	PACKING (USB)		166	4-984-017-71	SCREW (1.7), TAPPING	
156	3-386-371-21	PACKING, HP JACK		167	3-238-499-01	KNOB (S)	
157	X-3381-605-1	PLATE (OPEN) ASSY		168	3-238-498-01	ORNAMENT (R)	
158	3-238-524-01	ESCUTCHEON (OPEN)		169	3-238-500-01	ORNAMENT (S)	
159	3-238-509-01	PACKING (DC-IN)		170	3-238-483-01	SHEET (B), ADHESIVE	
160	3-318-382-91	SCREW (1.7X2.5), TAPPING		171	3-238-482-01	ORNAMENT (B)	
161	3-238-505-01	LEVER (HOLD)		172	3-243-012-01	SHEET (OPEN), ADHESIVE	

7-5. CASE (LOWER) SECTION-2

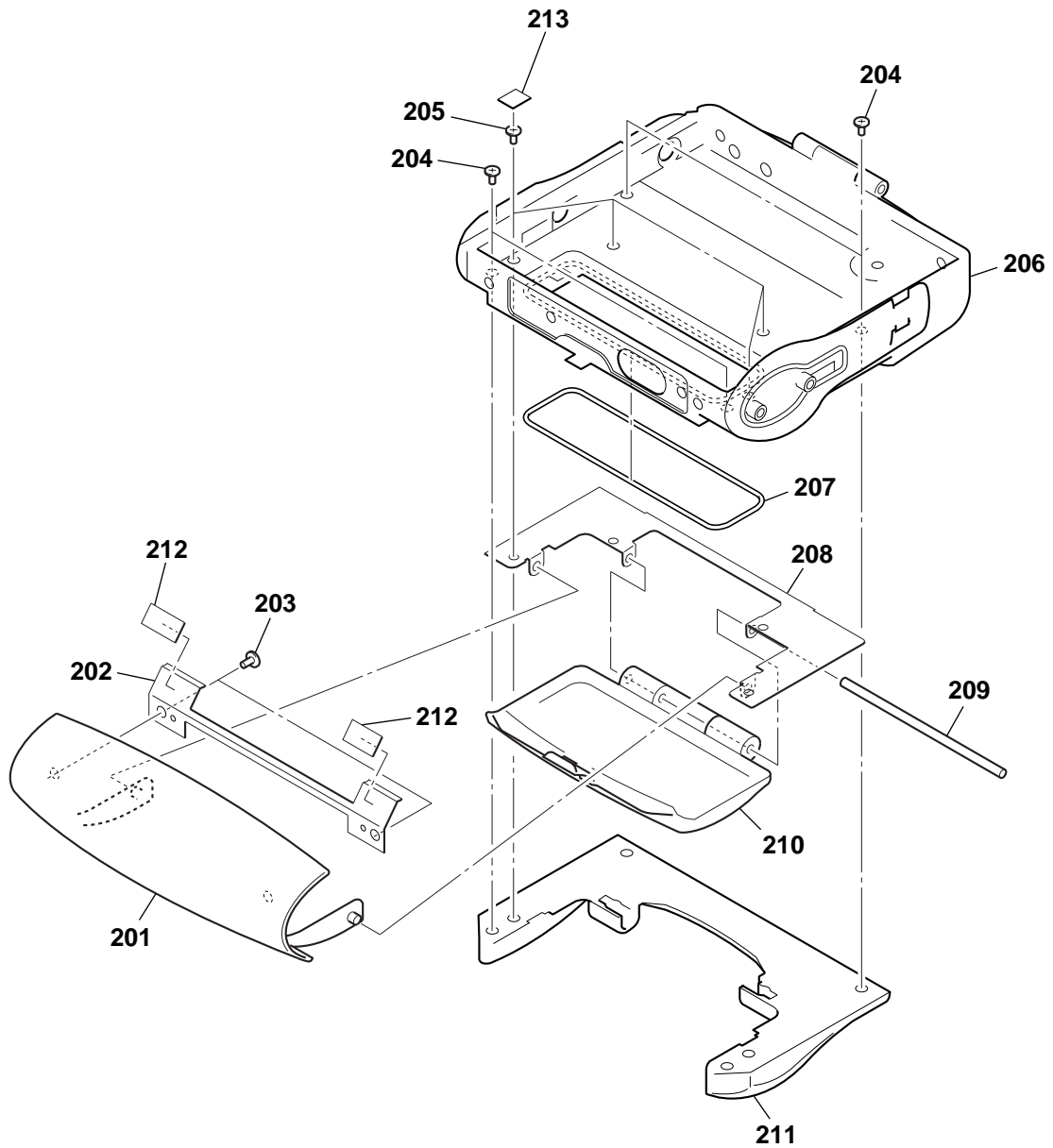

Ref. No.	Part No.	Description	Remark	Ref. No.	Part No.	Description	Remark
201	X-3381-606-1	BUCKLE (UPPER) ASSY		207	3-238-484-01	PACKING (BATTERY CASE LID)	
202	3-238-502-01	PLATE (BUCKLE), LOCK		208	3-238-511-01	PLATE (LOWER)	
203	3-318-382-91	SCREW (1.7X2.5), TAPPING		209	3-238-513-01	SHAFT (BATTERY CASE LID)	
204	4-984-017-21	SCREW (1.7), TAPPING		210	3-238-512-01	LID, BATTERY CASE	
205	3-225-873-29	SCREW (M1.4)		211	3-238-515-01	BUCKLE (LOWER)	
206	3-238-503-01	CASE (LOWER) (US, CND)		212	3-242-554-01	SPACER (BUCKLE)	
206	3-238-503-11	CASE (LOWER) (AEP, UK, FR)		213	3-242-557-01	SPACER (DC IN)	

7-6. MECHANISM DECK SECTION-1
(MT-MZN707-177)

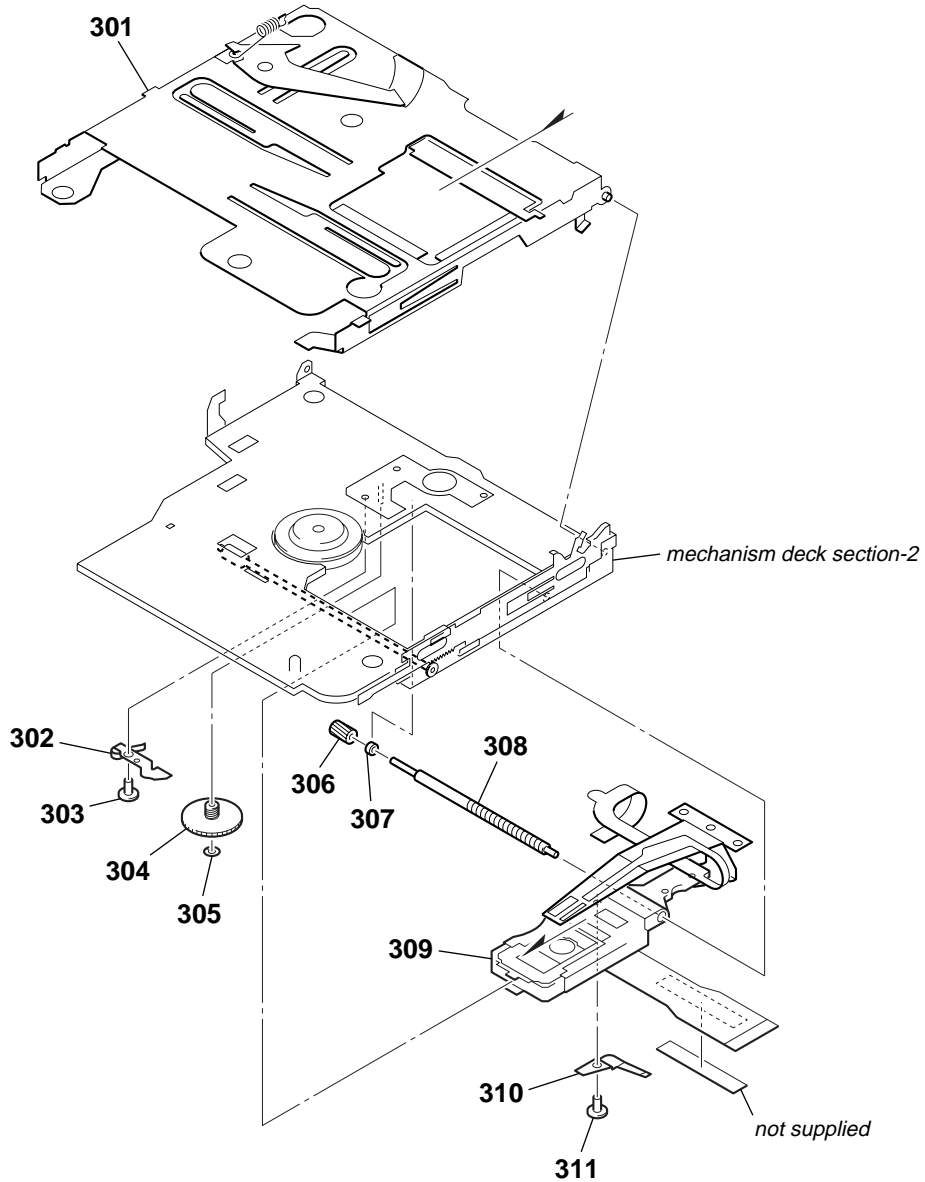

<p>The components identified by mark Δ or dotted line with mark Δ are critical for safety. Replace only with part number specified.</p>	<p>Les composants identifiés par une marque Δ sont critiques pour la sécurité. Ne les remplacer que par une pièce portant le numéro spécifié.</p>
---	---

Ref. No.	Part No.	Description	Remark	Ref. No.	Part No.	Description	Remark
301	X-3381-219-1	HOLDER ASSY		307	3-043-237-02	BEARING (N)	
302	3-224-779-02	SPRING, THRUST DETENT		308	4-222-203-02	SCREW, LEAD	
303	3-225-996-01	SCREW (M1.4) (EG), PRECISION PAN		Δ 309	X-3381-589-1	SERVICE ASSY, OP (LCX-5R)	
304	4-222-216-01	GEAR (SA)		310	3-049-336-03	SPRING (S), RACK	
305	3-338-645-31	WASHER (0.8-2.5)		311	3-225-996-06	SCREW (M1.4) (EG), PRECISION PAN	
306	4-222-208-01	GEAR (SB)					

7-7. MECHANISM DECK SECTION-2
(MT-MZN707-177)

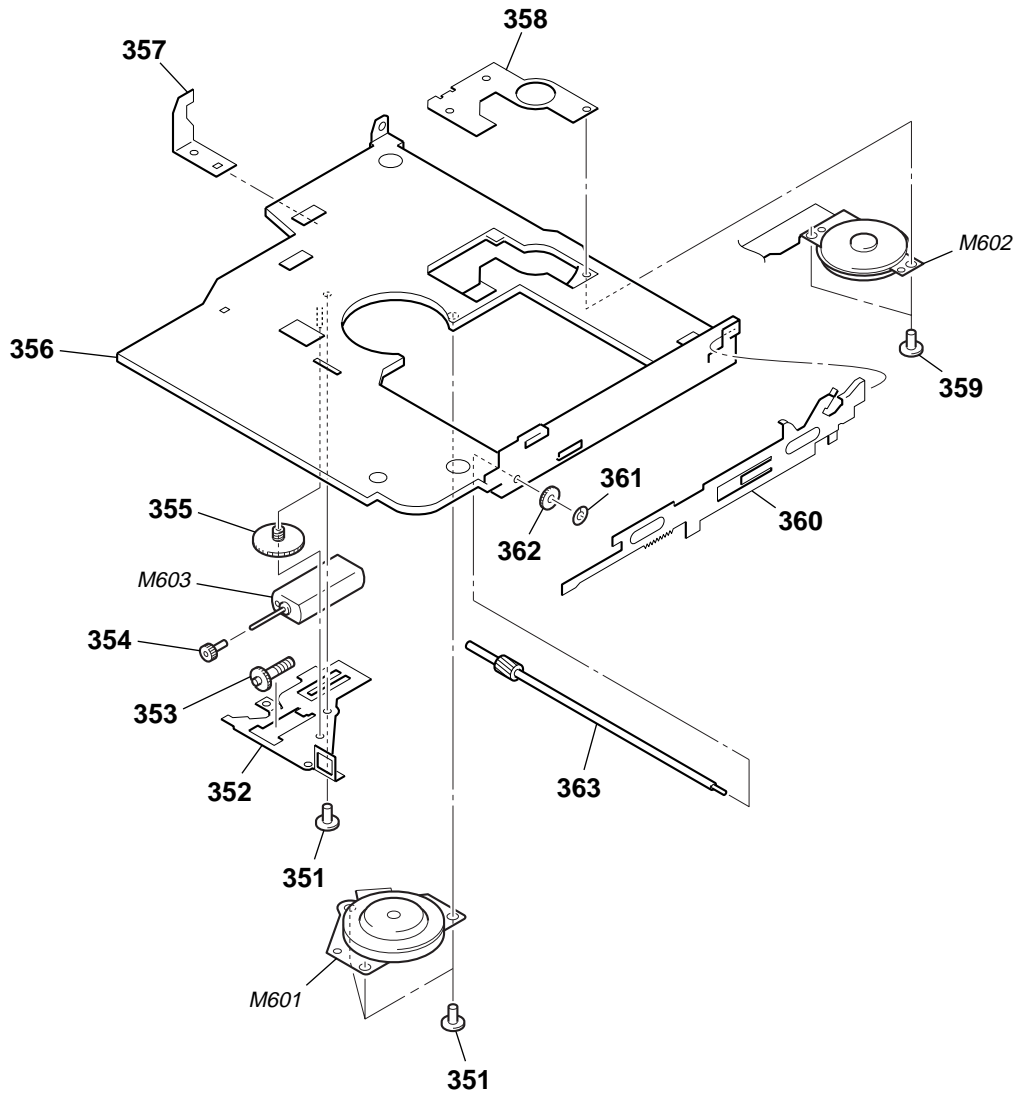

Ref. No.	Part No.	Description	Remark	Ref. No.	Part No.	Description	Remark
351	3-225-278-11	SCREW, TAPPING		360	3-235-839-01	LEVER (RACK)	
352	3-235-838-01	COVER, MOTOR		361	3-338-645-31	WASHER (0.8-2.5)	
353	3-235-836-01	GEAR (HB)		362	4-222-222-01	GEAR (RACK)	
354	3-222-544-01	GEAR (HA)		363	A-3174-089-A	SHAFT BLOCK ASSY, SUB	
355	3-235-835-01	GEAR (HC)		M601	8-835-744-01	MOTOR, DC SSM18B (SPINDLE) (WITH TURN TABLE)	
356	3-235-834-01	CHASSIS		M602	1-763-727-11	MOTOR, DC (SLED) (WITH GEAR)	
357	3-235-830-01	PLATE, RATCHET		M603	1-763-400-21	MOTOR, DC (OVER WRITE HEAD UP/DOWN)	
358	X-3379-529-4	BASE ASSY, MOTOR					
359	3-225-996-07	SCREW (M1.4) (EG), PRECISION PAN					

SECTION 8 ELECTRICAL PARTS LIST

NOTE:

- Due to standardization, replacements in the parts list may be different from the parts specified in the diagrams or the components used on the set.
- -XX and -X mean standardized parts, so they may have some difference from the original one.
- **RESISTORS**
All resistors are in ohms.
METAL: Metal-film resistor.
METAL OXIDE: Metal oxide-film resistor.
F: nonflammable
- Abbreviation
CND : Canadian model
FR : French model

- Items marked “*” are not stocked since they are seldom required for routine service. Some delay should be anticipated when ordering these items.
- **SEMICONDUCTORS**
In each case, u: μ , for example:
uA. . . : μ A. . . uPA. . . : μ PA. . .
uPB. . . : μ PB. . . uPC. . . : μ PC. . .
uPD. . . : μ PD. . .
- **CAPACITORS**
uF: μ F
- **COILS**
uH: μ H

The components identified by mark Δ or dotted line with mark Δ are critical for safety. Replace only with part number specified.

Les composants identifiés par une marque Δ sont critiques pour la sécurité. Ne les remplacer que par une pièce portant le numéro spécifié.

When indicating parts by reference number, please include the board.

Ref. No.	Part No.	Description	Remark	Ref. No.	Part No.	Description	Remark
	A-3021-764-B	MAIN BOARD, COMPLETE (FOR SERVICE)					

		< CAPACITOR >					
C101	1-125-889-11	CERAMIC CHIP	2.2uF 10% 10V	C505	1-164-943-11	CERAMIC CHIP	0.01uF 10% 16V
C102	1-164-941-11	CERAMIC CHIP	0.0047uF 10% 16V	C506	1-107-819-11	CERAMIC CHIP	0.022uF 10% 16V
C103	1-164-939-11	CERAMIC CHIP	0.0022uF 10% 50V	C507	1-107-819-11	CERAMIC CHIP	0.022uF 10% 16V
C104	1-135-868-11	TANTALUM CHIP	220uF 20% 2.5V	C508	1-125-777-11	CERAMIC CHIP	0.1uF 10% 10V
C105	1-115-467-11	CERAMIC CHIP	0.22uF 10% 10V	C509	1-164-939-11	CERAMIC CHIP	0.0022uF 10% 50V
C106	1-164-937-11	CERAMIC CHIP	0.001uF 10% 50V	C510	1-164-850-11	CERAMIC CHIP	10PF 0.5PF 50V
C110	1-125-837-11	CERAMIC CHIP	1uF 10% 6.3V	C511	1-164-850-11	CERAMIC CHIP	10PF 0.5PF 50V
C111	1-164-874-11	CERAMIC CHIP	100PF 5% 50V	C512	1-125-777-11	CERAMIC CHIP	0.1uF 10% 10V
C201	1-125-889-11	CERAMIC CHIP	2.2uF 10% 10V	C513	1-164-850-11	CERAMIC CHIP	10PF 0.5PF 50V
C202	1-164-941-11	CERAMIC CHIP	0.0047uF 10% 16V	C514	1-107-819-11	CERAMIC CHIP	0.022uF 10% 16V
C203	1-164-939-11	CERAMIC CHIP	0.0022uF 10% 50V	C515	1-125-777-11	CERAMIC CHIP	0.1uF 10% 10V
C204	1-135-868-11	TANTALUM CHIP	220uF 20% 2.5V	C516	1-125-777-11	CERAMIC CHIP	0.1uF 10% 10V
C205	1-115-467-11	CERAMIC CHIP	0.22uF 10% 10V	C518	1-127-760-11	CERAMIC CHIP	4.7uF 10% 6.3V
C206	1-164-937-11	CERAMIC CHIP	0.001uF 10% 50V	C519	1-164-941-11	CERAMIC CHIP	0.0047uF 10% 16V
C210	1-125-837-11	CERAMIC CHIP	1uF 10% 6.3V	C521	1-125-777-11	CERAMIC CHIP	0.1uF 10% 10V
C211	1-164-874-11	CERAMIC CHIP	100PF 5% 50V	C522	1-125-777-11	CERAMIC CHIP	0.1uF 10% 10V
C301	1-110-569-11	TANTALUM CHIP	47uF 20% 6.3V	C523	1-125-837-11	CERAMIC CHIP	1uF 10% 6.3V
C302	1-107-820-11	CERAMIC CHIP	0.1uF 16V	C524	1-135-259-11	TANTALUM CHIP	10uF 20% 6.3V
C305	1-135-149-21	TANTALUM CHIP	2.2uF 20% 10V	C527	1-119-923-11	CERAMIC CHIP	0.047uF 10% 10V
C306	1-107-820-11	CERAMIC CHIP	0.1uF 16V	C529	1-115-169-11	TANTALUM	10uF 20% 6.3V
C307	1-125-777-11	CERAMIC CHIP	0.1uF 10% 10V	C530	1-164-939-11	CERAMIC CHIP	0.0022uF 10% 50V
C308	1-125-777-11	CERAMIC CHIP	0.1uF 10% 10V	C531	1-164-943-11	CERAMIC CHIP	0.01uF 10% 16V
C311	1-125-777-11	CERAMIC CHIP	0.1uF 10% 10V	C551	1-125-777-11	CERAMIC CHIP	0.1uF 10% 10V
C312	1-125-889-11	CERAMIC CHIP	2.2uF 10% 10V	C557	1-119-923-11	CERAMIC CHIP	0.047uF 10% 10V
C314	1-135-259-11	TANTALUM CHIP	10uF 20% 6.3V	C558	1-119-923-11	CERAMIC CHIP	0.047uF 10% 10V
C315	1-125-837-11	CERAMIC CHIP	1uF 10% 6.3V	C559	1-119-923-11	CERAMIC CHIP	0.047uF 10% 10V
C316	1-135-201-11	TANTALUM CHIP	10uF 20% 4V	C561	1-125-777-11	CERAMIC CHIP	0.1uF 10% 10V
C320	1-135-151-21	TANTALUM CHIP	4.7uF 20% 4V	C562	1-107-819-11	CERAMIC CHIP	0.022uF 10% 16V
C321	1-125-777-11	CERAMIC CHIP	0.1uF 10% 10V	C563	1-107-819-11	CERAMIC CHIP	0.022uF 10% 16V
C325	1-164-937-11	CERAMIC CHIP	0.001uF 10% 50V	C564	1-107-819-11	CERAMIC CHIP	0.022uF 10% 16V
C326	1-164-937-11	CERAMIC CHIP	0.001uF 10% 50V	C565	1-164-943-11	CERAMIC CHIP	0.01uF 10% 16V
C330	1-107-820-11	CERAMIC CHIP	0.1uF 16V	C566	1-164-943-11	CERAMIC CHIP	0.01uF 10% 16V
C334	1-125-777-11	CERAMIC CHIP	0.1uF 10% 10V	C567	1-164-943-11	CERAMIC CHIP	0.01uF 10% 16V
C335	1-135-259-11	TANTALUM CHIP	10uF 20% 6.3V	C601	1-164-943-11	CERAMIC CHIP	0.01uF 10% 16V
C336	1-164-933-11	CERAMIC CHIP	220PF 10% 50V	C602	1-125-777-11	CERAMIC CHIP	0.1uF 10% 10V
C340	1-125-777-11	CERAMIC CHIP	0.1uF 10% 10V	C603	1-128-964-11	TANTALUM CHIP	100uF 20% 6.3V
C501	1-164-874-11	CERAMIC CHIP	100PF 5% 50V	C604	1-164-943-11	CERAMIC CHIP	0.01uF 10% 16V
C502	1-107-819-11	CERAMIC CHIP	0.022uF 10% 16V	C605	1-164-937-11	CERAMIC CHIP	0.001uF 10% 50V
C503	1-164-939-11	CERAMIC CHIP	0.0022uF 10% 50V	C606	1-164-874-11	CERAMIC CHIP	100PF 5% 50V
C504	1-164-939-11	CERAMIC CHIP	0.0022uF 10% 50V	C607	1-164-874-11	CERAMIC CHIP	100PF 5% 50V
				C608	1-125-777-11	CERAMIC CHIP	0.1uF 10% 10V
				C609	1-131-862-11	TANTALUM CHIP	47uF 20% 4V
				C611	1-135-259-11	TANTALUM CHIP	10uF 20% 6.3V

Ref. No.	Part No.	Description	Remark	Ref. No.	Part No.	Description	Remark
C612	1-135-259-11	TANTALUM CHIP 10uF	20% 6.3V	C839	1-164-937-11	CERAMIC CHIP 0.001uF	10% 50V
C613	1-125-777-11	CERAMIC CHIP 0.1uF	10% 10V	C840	1-164-943-11	CERAMIC CHIP 0.01uF	10% 16V
C614	1-125-777-11	CERAMIC CHIP 0.1uF	10% 10V	C841	1-164-941-11	CERAMIC CHIP 0.0047uF	10% 16V
C615	1-137-760-11	CAP-CHIP 100PF	5% 100V	C901	1-165-851-11	TANTALUM CHIP 10uF	20% 6.3V
C616	1-125-777-11	CERAMIC CHIP 0.1uF	10% 10V	C902	1-165-851-11	TANTALUM CHIP 10uF	20% 6.3V
C618	1-125-777-11	CERAMIC CHIP 0.1uF	10% 10V	C903	1-128-964-11	TANTALUM CHIP 100uF	20% 6.3V
C619	1-125-777-11	CERAMIC CHIP 0.1uF	10% 10V	C904	1-119-750-11	TANTALUM CHIP 22uF	20% 6.3V
C621	1-164-943-11	CERAMIC CHIP 0.01uF	10% 16V	C905	1-125-777-11	CERAMIC CHIP 0.1uF	10% 10V
C622	1-131-862-11	TANTALUM CHIP 47uF	20% 4V	C906	1-164-943-11	CERAMIC CHIP 0.01uF	10% 16V
C624	1-115-169-11	TANTALUM 10uF	20% 6.3V	C907	1-125-889-11	CERAMIC CHIP 2.2uF	10% 10V
C625	1-164-937-11	CERAMIC CHIP 0.001uF	10% 50V	C908	1-125-777-11	CERAMIC CHIP 0.1uF	10% 10V
C627	1-125-777-11	CERAMIC CHIP 0.1uF	10% 10V	C909	1-164-937-11	CERAMIC CHIP 0.001uF	10% 50V
C628	1-164-943-11	CERAMIC CHIP 0.01uF	10% 16V	C910	1-164-937-11	CERAMIC CHIP 0.001uF	10% 50V
C629	1-164-874-11	CERAMIC CHIP 100PF	5% 50V	C911	1-135-259-11	TANTALUM CHIP 10uF	20% 6.3V
C630	1-128-829-11	TANTALUM CHIP 220uF	20% 6.3V	C912	1-164-937-11	CERAMIC CHIP 0.001uF	10% 50V
C632	1-135-259-11	TANTALUM CHIP 10uF	20% 6.3V	C913	1-164-941-11	CERAMIC CHIP 0.0047uF	10% 16V
C633	1-125-777-11	CERAMIC CHIP 0.1uF	10% 10V	C914	1-125-777-11	CERAMIC CHIP 0.1uF	10% 10V
C634	1-125-777-11	CERAMIC CHIP 0.1uF	10% 10V	C915	1-125-777-11	CERAMIC CHIP 0.1uF	10% 10V
C638	1-128-829-11	TANTALUM CHIP 220uF	20% 6.3V	C916	1-125-837-11	CERAMIC CHIP 1uF	10% 6.3V
C639	1-125-777-11	CERAMIC CHIP 0.1uF	10% 10V	C917	1-125-777-11	CERAMIC CHIP 0.1uF	10% 10V
C701	1-137-739-11	TANTALUM 22uF	20% 6.3V	C918	1-125-889-11	CERAMIC CHIP 2.2uF	10% 10V
C702	1-164-939-11	CERAMIC CHIP 0.0022uF	10% 50V	C919	1-135-259-11	TANTALUM CHIP 10uF	20% 6.3V
C703	1-164-937-11	CERAMIC CHIP 0.001uF	10% 50V	C920	1-117-919-11	TANTALUM CHIP 10uF	20% 6.3V
C704	1-137-934-11	TANTALUM CHIP 47uF	20% 10V	C921	1-125-777-11	CERAMIC CHIP 0.1uF	10% 10V
C801	1-125-777-11	CERAMIC CHIP 0.1uF	10% 10V	C922	1-164-937-11	CERAMIC CHIP 0.001uF	10% 50V
C802	1-164-943-11	CERAMIC CHIP 0.01uF	10% 16V	C924	1-164-937-11	CERAMIC CHIP 0.001uF	10% 50V
C803	1-164-943-11	CERAMIC CHIP 0.01uF	10% 16V	C926	1-115-169-11	TANTALUM 10uF	20% 6.3V
C804	1-125-777-11	CERAMIC CHIP 0.1uF	10% 10V	C927	1-125-777-11	CERAMIC CHIP 0.1uF	10% 10V
C805	1-119-923-11	CERAMIC CHIP 0.047uF	10% 10V	C928	1-125-777-11	CERAMIC CHIP 0.1uF	10% 10V
C806	1-119-923-11	CERAMIC CHIP 0.047uF	10% 10V	< CONNECTOR >			
C807	1-164-850-11	CERAMIC CHIP 10PF	0.5PF 50V	CN501	1-573-360-21	CONNECTOR, FFC/FPC 20P	
C808	1-164-850-11	CERAMIC CHIP 10PF	0.5PF 50V	CN502	1-573-350-11	CONNECTOR, FFC/FPC 10P	
C809	1-137-739-11	TANTALUM 22uF	20% 6.3V	CN701	1-816-036-21	CONNECTOR (SQUARE TYPE) (USB) 5P (USB CONNECTOR)	
C810	1-125-837-11	CERAMIC CHIP 1uF	10% 6.3V	CN802	1-750-862-21	PIN, CONNECTOR (PC BOARD) 5P	
C811	1-125-837-11	CERAMIC CHIP 1uF	10% 6.3V	CN803	1-573-352-11	CONNECTOR, FFC/FPC 12P	
C812	1-164-943-11	CERAMIC CHIP 0.01uF	10% 16V	< DIODE >			
C813	1-125-891-11	CERAMIC CHIP 0.47uF	10% 10V	D101	8-719-056-72	DIODE UDZ-TE-17-2.4B	
C814	1-164-935-11	CERAMIC CHIP 470PF	10% 50V	D201	8-719-056-72	DIODE UDZ-TE-17-2.4B	
C815	1-110-569-11	TANTALUM CHIP 47uF	20% 6.3V	D601	8-719-081-33	DIODE MA2YD1500LS0	
C816	1-125-777-11	CERAMIC CHIP 0.1uF	10% 10V	D602	8-719-081-33	DIODE MA2YD1500LS0	
C817	1-109-982-11	CERAMIC CHIP 1uF	10% 10V	D603	8-719-081-33	DIODE MA2YD1500LS0	
C818	1-125-777-11	CERAMIC CHIP 0.1uF	10% 10V	D606	8-719-081-35	DIODE MA2YD1700LS0	
C819	1-107-819-11	CERAMIC CHIP 0.022uF	10% 16V	D607	8-719-081-33	DIODE MA2YD1500LS0	
C820	1-164-943-11	CERAMIC CHIP 0.01uF	10% 16V	D608	8-719-081-35	DIODE MA2YD1700LS0	
C821	1-137-740-11	TANTALUM 47uF	20% 6.3V	D701	8-719-421-28	DIODE MA728-TX	
C822	1-125-777-11	CERAMIC CHIP 0.1uF	10% 10V	D703	8-719-081-33	DIODE MA2YD1500LS0	
C823	1-107-820-11	CERAMIC CHIP 0.1uF	16V	D803	8-719-017-58	DIODE MA8068-TX	
C824	1-119-923-11	CERAMIC CHIP 0.047uF	10% 10V	D804	8-719-420-51	DIODE MA729-TX	
C825	1-164-874-11	CERAMIC CHIP 100PF	5% 50V	D901	8-719-081-33	DIODE MA2YD1500LS0	
C826	1-115-467-11	CERAMIC CHIP 0.22uF	10% 10V	D902	8-719-081-33	DIODE MA2YD1500LS0	
C828	1-125-837-11	CERAMIC CHIP 1uF	10% 6.3V	D903	8-719-420-51	DIODE MA729-TX	
C829	1-125-837-11	CERAMIC CHIP 1uF	10% 6.3V	D904	8-719-404-50	DIODE MA111-TX	
C830	1-125-777-11	CERAMIC CHIP 0.1uF	10% 10V	< RESISTOR >			
C832	1-164-850-11	CERAMIC CHIP 10PF	0.5PF 50V	FB701	1-216-864-11	METAL CHIP 0	5% 1/16W
C833	1-164-850-11	CERAMIC CHIP 10PF	0.5PF 50V				
C834	1-164-943-11	CERAMIC CHIP 0.01uF	10% 16V				
C838	1-117-720-11	CERAMIC CHIP 4.7uF	10V				

MZ-S1

MAIN

Ref. No.	Part No.	Description	Remark	Ref. No.	Part No.	Description	Remark
FB702	1-216-864-11	METAL CHIP	0 5% 1/16W	Q701	8-729-053-03	FET	XP151A12A2MR
FB703	1-216-864-11	METAL CHIP	0 5% 1/16W	Q703	8-729-037-86	TRANSISTOR	2SB1462J-R (TX).SO
FB704	1-216-864-11	METAL CHIP	0 5% 1/16W	Q704	8-729-041-51	TRANSISTOR	FMMT617TA
FB801	1-216-864-11	METAL CHIP	0 5% 1/16W	Q705	8-729-047-48	TRANSISTOR	UMD12N-TR
FB802	1-216-864-11	METAL CHIP	0 5% 1/16W	Q706	8-729-037-63	TRANSISTOR	UN9115J- (TX).SO
FB803	1-216-864-11	METAL CHIP	0 5% 1/16W	Q801	8-729-429-44	TRANSISTOR	XP1501-TXE
FB804	1-216-864-11	METAL CHIP	0 5% 1/16W	Q901	8-729-037-92	TRANSISTOR	2SD2216J-R (TX).SO
FB805	1-216-864-11	METAL CHIP	0 5% 1/16W	Q902	8-729-037-92	TRANSISTOR	2SD2216J-R (TX).SO
FB806	1-216-864-11	METAL CHIP	0 5% 1/16W	Q903	8-729-037-92	TRANSISTOR	2SD2216J-R (TX).SO
		< IC >		Q904	8-729-034-59	TRANSISTOR	2SA1745-6.7-TL
IC301	8-759-694-88	IC AK5354VT-E2				< RESISTOR >	
IC302	8-759-598-15	IC TA2131FL (EL)		R101	1-218-969-11	RES-CHIP	22K 5% 1/16W
IC501	6-701-391-01	IC SN761057ADBT		R103	1-218-973-11	RES-CHIP	47K 5% 1/16W
IC551	6-700-680-01	IC SC111258FCR2		R104	1-218-965-11	RES-CHIP	10K 5% 1/16W
IC601	6-701-477-01	IC XPC18A22AFCR2		R105	1-218-961-11	RES-CHIP	4.7K 5% 1/16W
IC604	6-700-958-01	IC XC61FS1YXXMR		R106	1-208-635-11	RES-CHIP	10 5% 1/16W
IC702	6-702-333-01	IC XC6367A361MR		R107	1-218-965-11	RES-CHIP	10K 5% 1/16W
IC801	(Not supplied)	IC CXD2677-202GA		R111	1-208-919-11	METAL CHIP	22K 0.5% 1/16W
IC804	8-759-593-47	IC AK6417AM-E2		R112	1-208-927-11	METAL CHIP	47K 0.5% 1/16W
IC901	8-759-698-61	IC XPC18A32FCR2		R201	1-218-969-11	RES-CHIP	22K 5% 1/16W
IC902	6-701-978-01	IC XC61CN0802NR		R203	1-218-973-11	RES-CHIP	47K 5% 1/16W
		< JACK >		R204	1-218-965-11	RES-CHIP	10K 5% 1/16W
J301	1-793-619-21	JACK (LINE IN (OPTICAL))		R205	1-218-961-11	RES-CHIP	4.7K 5% 1/16W
J304	1-816-037-11	JACK (☹)		R206	1-208-635-11	RES-CHIP	10 5% 1/16W
J601	1-785-383-11	JACK, DC (POLARITY UNIFIED TYPE) (DC IN 3V)		R207	1-218-965-11	RES-CHIP	10K 5% 1/16W
		< COIL/SHORT >		R211	1-208-919-11	METAL CHIP	22K 0.5% 1/16W
L301	1-414-398-11	INDUCTOR	10uH	R212	1-208-927-11	METAL CHIP	47K 0.5% 1/16W
L501	1-414-398-11	INDUCTOR	10uH	R302	1-218-953-11	RES-CHIP	1K 5% 1/16W
L502	1-414-398-11	INDUCTOR	10uH	R303	1-218-937-11	RES-CHIP	47 5% 1/16W
L551	1-216-296-11	SHORT	0	R304	1-218-953-11	RES-CHIP	1K 5% 1/16W
L552	1-216-296-11	SHORT	0	R305	1-218-953-11	RES-CHIP	1K 5% 1/16W
L553	1-216-296-11	SHORT	0	R306	1-218-969-11	RES-CHIP	22K 5% 1/16W
L554	1-216-296-11	SHORT	0	R307	1-218-941-11	RES-CHIP	100 5% 1/16W
L601	1-428-912-21	CHOKE COIL	10uH	R309	1-218-981-11	RES-CHIP	220K 5% 1/16W
L602	1-414-398-11	INDUCTOR	10uH	R310	1-218-990-11	SHORT	0
L701	1-469-952-21	CHOKE COIL	22uH	R311	1-218-989-11	RES-CHIP	1M 5% 1/16W
L801	1-216-296-11	SHORT	0	R315	1-218-965-11	RES-CHIP	10K 5% 1/16W
L802	1-469-535-21	INDUCTOR	10uH	R316	1-218-977-11	RES-CHIP	100K 5% 1/16W
L901	1-419-953-21	CHOKE COIL	100uH	R317	1-218-941-11	RES-CHIP	100 5% 1/16W
L902	1-419-949-21	CHOKE COIL	22uH	R318	1-218-953-11	RES-CHIP	1K 5% 1/16W
L904	1-414-398-11	INDUCTOR	10uH	R320	1-218-965-11	RES-CHIP	10K 5% 1/16W
L905	1-469-426-21	INDUCTOR	100uH	R501	1-218-973-11	RES-CHIP	47K 5% 1/16W
L906	1-469-367-21	INDUCTOR	10uH	R502	1-218-981-11	RES-CHIP	220K 5% 1/16W
		< TRANSISTOR >		R503	1-218-985-11	RES-CHIP	470K 5% 1/16W
Q301	8-729-037-52	TRANSISTOR	2SC4738F-Y/GR (TPL3)	R505	1-208-707-11	METAL CHIP	10K 0.5% 1/16W
Q302	8-729-051-23	TRANSISTOR	2SA2018TL	R507	1-218-953-11	RES-CHIP	1K 5% 1/16W
Q501	8-729-922-10	TRANSISTOR	2SA1577-T106-QR	R517	1-208-683-11	METAL CHIP	1K 0.5% 1/16W
Q601	8-729-046-45	FET	SI2302DS-T1	R519	1-218-977-11	RES-CHIP	100K 5% 1/16W
Q603	8-729-053-71	FET	TS8K1TB	R521	1-218-446-11	METAL CHIP	1 5% 1/10W
Q604	8-729-046-43	FET	HAT2051T-EL	R522	1-218-446-11	METAL CHIP	1 5% 1/10W
Q605	8-729-046-42	FET	HAT2050T-EL	R551	1-218-965-11	RES-CHIP	10K 5% 1/16W
Q610	8-729-037-71	TRANSISTOR	UN9210J- (TX).SO	R552	1-218-965-11	RES-CHIP	10K 5% 1/16W
Q611	8-729-042-81	TRANSISTOR	FZT788BTC	R553	1-218-965-11	RES-CHIP	10K 5% 1/16W
				R560	1-218-957-11	RES-CHIP	2.2K 5% 1/16W
				R561	1-218-957-11	RES-CHIP	2.2K 5% 1/16W
				R562	1-218-957-11	RES-CHIP	2.2K 5% 1/16W

Ref. No.	Part No.	Description			Remark	Ref. No.	Part No.	Description			Remark
R601	1-218-989-11	RES-CHIP	1M	5%	1/16W	R834	1-208-935-11	METAL CHIP	100K	0.5%	1/16W
R602	1-218-981-11	RES-CHIP	220K	5%	1/16W	R835	1-218-985-11	METAL CHIP	470K	0.5%	1/16W
R603	1-218-977-11	RES-CHIP	100K	5%	1/16W						
R607	1-218-945-11	RES-CHIP	220	5%	1/16W	R838	1-218-949-11	RES-CHIP	470	5%	1/16W
R608	1-218-981-11	RES-CHIP	220K	5%	1/16W	R839	1-218-989-11	RES-CHIP	1M	5%	1/16W
						R840	1-216-809-11	METAL CHIP	100	5%	1/16W
R609	1-219-724-11	METAL CHIP	1	1%	1/4W	R841	1-218-990-11	SHORT	0		
R610	1-218-969-11	RES-CHIP	22K	5%	1/16W	R843	1-216-864-11	METAL CHIP	0	5%	1/16W
R612	1-218-985-11	RES-CHIP	470K	5%	1/16W						
R613	1-218-957-11	RES-CHIP	2.2K	5%	1/16W	R844	1-218-990-11	SHORT	0		
R614	1-218-965-11	RES-CHIP	10K	5%	1/16W	R845	1-208-643-11	RES-CHIP	22	5%	1/16W
						R846	1-208-643-11	RES-CHIP	22	5%	1/16W
R616	1-218-977-11	RES-CHIP	100K	5%	1/16W	R847	1-218-990-11	SHORT	0		
R620	1-218-965-11	RES-CHIP	10K	5%	1/16W	R849	1-218-990-11	SHORT	0		
R621	1-218-965-11	RES-CHIP	10K	5%	1/16W						
R622	1-218-977-11	RES-CHIP	100K	5%	1/16W	R850	1-218-990-11	SHORT	0		
R623	1-218-977-11	RES-CHIP	100K	5%	1/16W	R851	1-218-990-11	SHORT	0		
						R852	1-208-931-11	METAL CHIP	68K	0.5%	1/16W
R624	1-216-797-11	METAL CHIP	10	5%	1/16W	R853	1-218-990-11	SHORT	0		
R701	1-218-953-11	RES-CHIP	1K	5%	1/16W	R855	1-218-990-11	SHORT	0		
R702	1-218-985-11	RES-CHIP	470K	5%	1/16W						
R703	1-218-985-11	RES-CHIP	470K	5%	1/16W	R857	1-218-953-11	RES-CHIP	1K	5%	1/16W
R704	1-218-990-11	SHORT	0			R858	1-218-989-11	RES-CHIP	1M	5%	1/16W
						R859	1-218-953-11	RES-CHIP	1K	5%	1/16W
R705	1-218-957-11	RES-CHIP	2.2K	5%	1/16W	R860	1-218-953-11	RES-CHIP	1K	5%	1/16W
R706	1-218-977-11	RES-CHIP	100K	5%	1/16W	R861	1-218-953-11	RES-CHIP	1K	5%	1/16W
R707	1-218-961-11	RES-CHIP	4.7K	5%	1/16W						
R708	1-218-985-11	RES-CHIP	470K	5%	1/16W	R863	1-218-977-11	RES-CHIP	100K	5%	1/16W
R709	1-218-941-11	RES-CHIP	100	5%	1/16W	R864	1-218-977-11	RES-CHIP	100K	5%	1/16W
						R902	1-218-985-11	RES-CHIP	470K	5%	1/16W
R710	1-218-957-11	RES-CHIP	2.2K	5%	1/16W	R903	1-218-957-11	RES-CHIP	2.2K	5%	1/16W
R711	1-216-864-11	METAL CHIP	0	5%	1/16W	R905	1-218-957-11	RES-CHIP	2.2K	5%	1/16W
R712	1-218-961-11	RES-CHIP	4.7K	5%	1/16W						
R714	1-218-990-11	SHORT	0			R906	1-218-990-11	SHORT	0		
R715	1-218-973-11	RES-CHIP	47K	5%	1/16W	R907	1-218-989-11	RES-CHIP	1M	5%	1/16W
						R908	1-218-977-11	RES-CHIP	100K	5%	1/16W
R801	1-218-981-11	RES-CHIP	220K	5%	1/16W	R909	1-218-965-11	RES-CHIP	10K	5%	1/16W
R802	1-208-927-11	METAL CHIP	47K	0.5%	1/16W	R910	1-218-965-11	RES-CHIP	10K	5%	1/16W
R803	1-208-927-11	METAL CHIP	47K	0.5%	1/16W						
R804	1-218-957-11	RES-CHIP	2.2K	5%	1/16W	R911	1-218-949-11	RES-CHIP	470	5%	1/16W
R805	1-218-957-11	RES-CHIP	2.2K	5%	1/16W	R914	1-218-941-11	RES-CHIP	100	5%	1/16W
						R915	1-208-691-11	METAL CHIP	2.2K	0.5%	1/16W
R806	1-218-949-11	RES-CHIP	470	5%	1/16W	R916	1-218-981-11	RES-CHIP	220K	5%	1/16W
R807	1-208-635-11	RES-CHIP	10	5%	1/16W	R917	1-208-699-11	METAL CHIP	4.7K	0.5%	1/16W
R808	1-218-965-11	RES-CHIP	10K	5%	1/16W						
R809	1-218-977-11	RES-CHIP	100K	5%	1/16W	R918	1-208-707-11	METAL CHIP	10K	0.5%	1/16W
R810	1-218-977-11	RES-CHIP	100K	5%	1/16W	R919	1-208-927-11	METAL CHIP	47K	0.5%	1/16W
						R920	1-208-707-11	METAL CHIP	10K	0.5%	1/16W
R812	1-218-990-11	SHORT	0			R921	1-218-985-11	RES-CHIP	470K	5%	1/16W
R814	1-208-635-11	RES-CHIP	10	5%	1/16W	R922	1-218-969-11	RES-CHIP	22K	5%	1/16W
R815	1-218-990-11	SHORT	0								
R816	1-218-990-11	SHORT	0			R923	1-218-981-11	RES-CHIP	220K	5%	1/16W
R817	1-218-977-11	RES-CHIP	100K	5%	1/16W	R924	1-218-981-11	RES-CHIP	220K	5%	1/16W
						R925	1-218-981-11	RES-CHIP	220K	5%	1/16W
R821	1-218-981-11	RES-CHIP	220K	5%	1/16W	R927	1-218-989-11	RES-CHIP	1M	5%	1/16W
R822	1-218-953-11	RES-CHIP	1K	5%	1/16W	R928	1-218-977-11	RES-CHIP	100K	5%	1/16W
R823	1-218-945-11	RES-CHIP	220	5%	1/16W						
R824	1-218-957-11	RES-CHIP	2.2K	5%	1/16W	R936	1-208-919-11	METAL CHIP	22K	0.5%	1/16W
R825	1-220-804-11	RES-CHIP	2.2M	5%	1/16W	R941	1-218-969-11	RES-CHIP	22K	5%	1/16W
						R946	1-208-707-11	METAL CHIP	10K	0.5%	1/16W
R826	1-218-990-11	SHORT	0			R947	1-208-683-11	METAL CHIP	1K	0.5%	1/16W
R827	1-216-864-11	METAL CHIP	0	5%	1/16W	R948	1-208-935-11	METAL CHIP	100K	0.5%	1/16W
R828	1-208-691-11	METAL CHIP	2.2K	0.5%	1/16W						
R829	1-208-699-11	METAL CHIP	4.7K	0.5%	1/16W						
R830	1-218-989-11	RES-CHIP	1M	5%	1/16W						
R831	1-218-990-11	SHORT	0			S801	1-762-078-11	SWITCH, SLIDE (HOLD)			
R832	1-218-985-11	RES-CHIP	470K	5%	1/16W	S803	1-771-867-11	SWITCH, PUSH (1 KEY) (PROTECT DETECT)			
R833	1-218-957-11	RES-CHIP	2.2K	5%	1/16W	S805	1-762-947-12	SWITCH, PUSH (1 KEY) (HALF LOCK)			

< SWITCH >

MZ-S1

MAIN

Ref. No.	Part No.	Description	Remark
S806	1-762-805-21	SWITCH, PUSH (1 KEY) (OPEN/CLOSE DETECT)	
		< LINE FILTER >	
T601	1-416-405-21	LINE FILTER	
		< THERMISTOR >	
TH601	1-804-616-21	THERMISTOR, POSITIVE	
		< VIBRATOR >	
X801	1-795-024-11	VIBRATOR, CRYSTAL (45.1584MHz)	
X802	1-795-443-21	VIBRATOR, CRYSTAL (48MHz)	

MISCELLANEOUS

8	1-804-544-11	LCD MODULE	
165	1-476-938-11	SWITCH UNIT	
△ 309	X-3381-589-1	SERVICE ASSY, OP (LCX-5R)	
M601	8-835-744-01	MOTOR, DC SSM18B (SPINDLE) (WITH TURN TABLE)	
M602	1-763-727-11	MOTOR, DC (SLED) (WITH GEAR)	
M603	1-763-400-21	MOTOR, DC (OVER WRITE HEAD UP/DOWN)	

ACCESSORIES

△	1-476-857-11	ADAPTOR, AC (AC-ES305) (AEP, FR)	
△	1-476-858-11	ADAPTOR, AC (AC-ES305) (UK)	
△	1-476-859-11	ADAPTOR, AC (AC-ES305) (US, CND)	
	1-816-206-11	CONNECTOR, LIGHT (OPTICAL CABLE) (AEP, UK, FR)	
	1-823-519-11	CORD, CONNECTION (USB CABLE)	
	3-237-042-11	SOFT (CD-ROM), APPLICATION (US, CND)	
	3-237-042-21	SOFT (CD-ROM), APPLICATION (AEP, UK, FR)	
	3-238-523-01	STRAP, HAND	
	3-239-099-12	MANUAL, INSTRUCTION (ENGLISH, FRENCH, SPANISH)	
	3-239-099-21	MANUAL, INSTRUCTION (SWEDISH, PORTUGUESE, FINNISH) (AEP)	
	3-239-099-31	MANUAL, INSTRUCTION (GERMAN, DUTCH, ITALIAN) (AEP)	
	3-239-304-11	MANUAL, INSTRUCTION (How to Install) (Simple Burner) (ENGLISH) (US, CND)	
	3-239-304-21	MANUAL, INSTRUCTION (How to Install) (Simple Burner) (FRENCH) (CND)	
	3-239-305-11	CARD (OPERATING INSTRUCTION) (Simple Burner) (ENGLISH) (US, CND)	
	3-239-305-21	CARD (OPERATING INSTRUCTION) (Simple Burner) (FRENCH) (CND)	
	3-239-307-11	MANUAL, INSTRUCTION (OpenMG Jukebox) (ENGLISH) (US, CND, AEP, UK)	
	3-239-307-21	MANUAL, INSTRUCTION (OpenMG Jukebox) (FRENCH) (CND, AEP, FR)	
	3-239-307-31	MANUAL, INSTRUCTION (OpenMG Jukebox) (GERMAN) (AEP)	
	3-239-307-41	MANUAL, INSTRUCTION (OpenMG Jukebox) (SPANISH) (AEP)	
	3-239-307-51	MANUAL, INSTRUCTION (OpenMG Jukebox) (DUTCH) (AEP)	

Ref. No.	Part No.	Description	Remark
	3-239-307-61	MANUAL, INSTRUCTION (OpenMG Jukebox) (SWEDISH) (AEP)	
	3-239-307-71	MANUAL, INSTRUCTION (OpenMG Jukebox) (ITALIAN) (AEP)	
	3-239-307-91	MANUAL, INSTRUCTION (OpenMG Jukebox) (FINNISH) (AEP)	
	8-953-284-95	RECEIVER, EAR MDR-W014LP/WK (US, CND)	
	8-954-008-94	RECEIVER MDR-E808LP/WC (AEP, UK, FR)	

The components identified by mark △ or dotted line with mark △ are critical for safety. Replace only with part number specified.

Les composants identifiés par une marque △ sont critiques pour la sécurité. Ne les remplacer que par une pièce portant le numéro spécifié.

MEMO

