

MDS-JE500

SERVICE MANUAL

Ver 1.1 2001.12
With SUPPLEMENT-1
(9-960-726-81)

US Model
Canadian Model
AEP Model
UK Model
E Model
Tourist Model

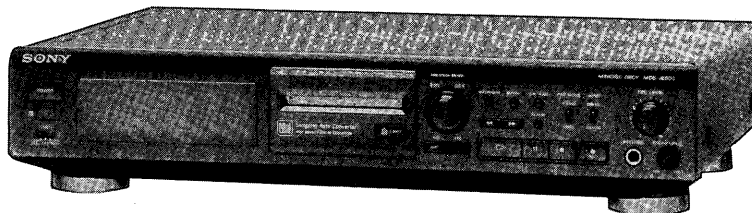

U.S. and foreign patents licensed from Dolby Laboratories Licensing Corporation.

Model Name Using Similar Mechanism	NEW
MD Mechanism Type	MDM-3A
Optical Pick-up Type	KMS-260A/J1N

SPECIFICATIONS

System	MiniDisc digital audio system
Disc	MiniDisc
Laser	Semiconductor laser ($\lambda = 780 \text{ nm}$) Emission duration: continuous
Laser output	Less than $44.6 \mu\text{W}^*$ * This output is the value measured at a distance of 200 mm from the objective lens surface on the Optical Pick-up Block with 7 mm aperture.
Laser diode properties	Material: GaAlAs
Revolutions (CLV)	400 rpm to 900 rpm
Error correction	Advanced Cross Interleave Reed Solomon Code (ACIRC)
Sampling frequency	44.1 kHz
Coding	Adaptive Transform Acoustic Coding (ATRAC)
Modulation system	EFM (Eight-to-Fourteen Modulation)
Number of channels	2 stereo channels
Frequency response	5 to 20,000 Hz $\pm 0.3 \text{ dB}$
Signal-to-noise ratio	Over 96 dB during playback
Wow and flutter	Below measurable limit

Inputs

	Jack type	Input impedance	Rated input	Minimum input
LINE (ANALOG) IN	Phono jacks	47 kilohms	500 mVrms	125 mVrms
DIGITAL IN	Square optical connector jack	Optical wave length: 660 nm	—	—

Outputs

	Jack type	Rated output	Load impedance
PHONES	Stereo phone jack	10 mW	32 ohms
LINE (ANALOG) OUT	Phono jacks	2 Vrms (at 50 kilohms)	Over 10 kilohms
DIGITAL OUT	Square optical connector jack	-18 dBm	Wave length: 660 nm

General

Power requirements

Where purchased	Power requirements
Continental Europe	220 - 230 V AC, 50/60 Hz
UK	220 - 240 V AC, 50/60 Hz
US, Canada	120 V AC, 60 Hz
Other countries	110 - 120, 220 - 240 V AC, 50/60 Hz

— Continued on next page —

Power consumption

Where purchased	Power consumption
Continental Europe and UK	20 W
US, Canada	19 W
Other countries	20 W

Dimensions (approx.) (w/h/d) incl. projecting parts
430 × 93 × 280.5 mm
(17 × 3 3/4 × 11 1/4 in.)

Mass (approx.) 3.5 kg (7 lbs 11 oz)

Supplied accessories

- Audio connecting cords (2)
- Optical cable (1)
- Remote commander (remote) RM-D7M (1)
- Sony SUM-3 (NS) batteries (2)

Design and specifications are subject to change without notice.

CAUTION

Danger of explosion if battery is incorrectly replaced.
Replace only with the same or equivalent type recommended by the equipment manufacturer.
Discard used batteries according to manufacture's instructions.

ADVARSEL!

Lithiumbatteri - Eksplosionsfare ved fejlagtig håndtering.
Udskiftning må kun ske med batteri af samme fabrikat og type.
Levér det brugte batteri tilbage til leverandøren.

ADVARSEL

Eksplosjonsfare ved feilaktig skifte av batteri.
Benytt samme batteritype eller en tilsvarende type anbefalt av apparatfabrikanten.
Brukte batterier katterier kasseres i henhold til fabrikantens

VARNIG

Explosionsfara vid felaktigt batteribyte.
Använd samma batterityp eller en likvärdig typ som rekommenderas av apparattillverkaren.
Kassera använt batteri enligt gällande förekrifter.

VAROITUS

Parist voi räjähtää, jos se on virheellisesti asennettu.
Vaihda paristo ainoastaan laitevalmistajan suosittelemaan tyyppiin.
Hävitätä käytetty paristo valmistajan ohjeiden mukaisesti.

Laser component in this product is capable of emitting radiation exceeding the limit for Class 1.

CLASS 1 LASER PRODUCT
LUOKAN 1 LASERLAITE
KLASS 1 LASERAPPARAT

This appliance is classified as a CLASS 1 LASER product. The CLASS 1 LASER PRODUCT MARKING is located on the rear exterior.

CAUTION ; INVISIBLE LASER RADIATION WHEN OPEN.
AVOID EXPOSURE TO BEAM.
ADVARSEL ; USYNLIG LASERSTRÅLING VED ÅBNING NÅR SIKKERHEDSÅBRYDERSER ER UDE AF FUNKTION.
UNDGÅ UDSÆTTELSE FOR STRÅLING.
VARO! ; AVAISTAESSA JA SUOJALUKITUS OHITETTAESSA
OLET ALTTIINA LASERSÄTELYLLE.
VARNING ; LASERSTRÅLING NÅR DENNA DEL ÄR ÖPPNAD
OCH SPÅRREN ÄR URKOPPLAD.
ADVARSEL ; USYNLIG LASERSTRÅLING NÅR DEKSEL ÅPNES
UNNGÅ EKSPONERING FOR STRÅLEN.

This caution label is located inside the unit.

CAUTION

Use of controls or adjustments or performance of procedures other than those specified herein may result in hazardous radiation exposure.

Notes on chip component replacement

- Never reuse a disconnected chip component.
- Notice that the minus side of a tantalum capacitor may be damaged by heat.

Flexible Circuit Board Repairing

- Keep the temperature of soldering iron around 270°C during repairing.
- Do not touch the soldering iron on the same conductor of the circuit board (within 3 times).
- Be careful not to apply force on the conductor when soldering or unsoldering.

SAFETY-RELATED COMPONENT WARNING !!

COMPONENTS IDENTIFIED BY MARK Δ OR DOTTED LINE WITH MARK Δ ON THE SCHEMATIC DIAGRAMS AND IN THE PARTS LIST ARE CRITICAL TO SAFE OPERATION. REPLACE THESE COMPONENTS WITH SONY PARTS WHOSE PART NUMBERS APPEAR AS SHOWN IN THIS MANUAL OR IN SUPPLEMENTS PUBLISHED BY SONY.

ATTENTION AU COMPOSANT AYANT RAPPORT À LA SÉCURITÉ!!

LES COMPOSANTS IDENTIFIÉS PAR UNE MARQUE Δ SUR LES DIAGRAMMES SCHÉMATIQUES ET LA LISTE DES PIÈCES SONT CRITIQUES POUR LA SÉCURITÉ DE FONCTIONNEMENT. NE REMPLACER CES COMPOSANTS QUE PAR DES PIÈCES SONY DONT LES NUMÉROS SONT DONNÉS DANS CE MANUEL OU DANS LES SUPPLÉMENTS PUBLIÉS PAR SONY.

SAFETY CHECK-OUT

After correcting the original service problem, perform the following safety checks before releasing the set to the customer:

Check the antenna terminals, metal trim, "metallized" knobs, screws, and all other exposed metal parts for AC leakage. Check leakage as described below.

LEAKAGE

The AC leakage from any exposed metal part to earth Ground and from all exposed metal parts to any exposed metal part having a return to chassis, must not exceed 0.5 mA (500 microamperes). Leakage current can be measured by any one of three methods.

1. A commercial leakage tester, such as the Simpson 229 or RCA WT-540A. Follow the manufacturers' instructions to use these instruments.
2. A battery-operated AC milliammeter. The Data Precision 245 digital multimeter is suitable for this job.
3. Measuring the voltage drop across a resistor by means of a VOM or battery-operated AC voltmeter. The "limit" indication is 0.75 V, so analog meters must have an accurate low-voltage scale. The Simpson 250 and Sanwa SH-63Trd are examples of a passive VOM that is suitable. Nearly all battery operated digital multimeters that have a 2V AC range are suitable. (See Fig. A)

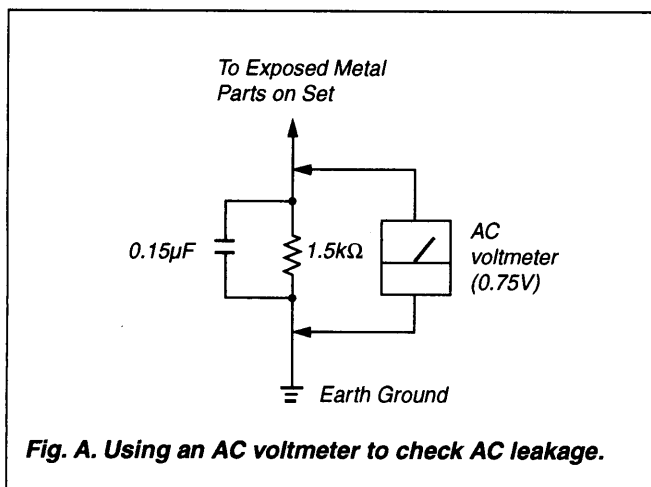

MODEL IDENTIFICATION — BACK PANEL —

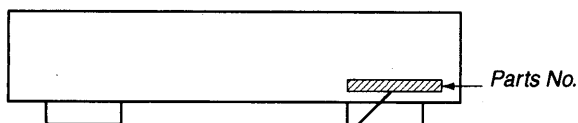

- 4-983-660-1□: US model
- 4-983-660-2□: Canadian model
- 4-983-660-3□: AEP, German model
- 4-983-660-4□: UK model
- 4-983-660-5□: Singapore, Tourist model
- 4-983-660-6□: Hong Kong model

TABLE OF CONTENTS

1. GENERAL	4
2. DISASSEMBLY	
2-1. Case and Front Panel Assembly	18
2-2. Bracket (T), (L) and (R)	18
2-3. BD Board	19
2-4. Sub Chassis	19
2-5. Shutter assembly	20
2-6. Over Write Head	20
2-7. Slider complete Assembly	21
3. TEST MODE	
3-1. Precautions for Use of Test Mode	22
3-1-1. Recording laser emission mode and operating buttons	22
3-2. Setting the Test Mode	22
3-3. Exiting the Test Mode	22
3-4. Basic Operations of the Test Mode	22
3-5. Selecting the Test Mode	22
3-5-1. Operating the Continuous Playback Mode	23
3-5-2. Operating the Continuous Recording Mode	23
3-5-3. Non-Volatile Memory Mode	23
3-6. Functions of Other buttons	24
3-7. Test Mode Displays	24
3-8. Meanings of Other Displays	24
4. ELECTRICAL ADJUSTMENTS	
4-1. Precautions for Checking Laser Diode Emission	25
4-2. Precautions for Use of optical pick-up (KMS-260A)	25
4-3. Precautions for Adjustments	25
4-4. Creating Continuously Recorded Disc	25
4-5. Temperature Compensation Offset Adjustment	26
4-6. Laser Power Adjustment	26
4-7. Traverse Adjustment	27
4-8. Focus Bias Adjustment	28
4-9. Error Rate Check	28
4-9-1. CD Error Rate Check	28
4-9-2. MO Error Rate Check	28
4-10. Focus Bias Check	28
4-11. Adjusting Points and Connecting Points	29
5. DIAGRAMS	
5-1. Circuit Boards Location	30
5-2. Block Diagrams	31
5-3. Printed Wiring Board — BD Section —	36
5-4. Schematic Diagram — BD Section —	39
5-5. Schematic Diagram — Main Section —	43
5-6. Printed Wiring Board — Main Section —	47
5-7. Printed Wiring Board — Panel Section —	49
5-8. Schematic Diagram — Panel Section —	51
5-9. IC Block Diagrams — BD Section — / — Main Section —	54
5-10. IC Pin Functions	
• IC101 RF Amplifier (CXA2523R)	57
• IC121 Digital Signal Processor, Digital Servo Signal Processor, EFM/ACIRC Encoder/Decoder, Shock-proof Memory Controller, ATRAC Encoder/ Decoder, 2M Bit DRAM (CXD2650R)	58
• IC307 A/D, D/A converter (CXD8607N)	61
• IC316 System Control (RU8X11AMF-0101)	63
6. EXPLODED VIEWS	
6-1. Case Section	66
6-2. Front Panel Section	67
6-3. Mechanism Deck Section (1) (MDM-3A)	68
6-4. Mechanism Deck Section (2) (MDM-3A)	69
7. ELECTRICAL PARTS LIST	70

SECTION 1 GENERAL

Location of Parts and Controls

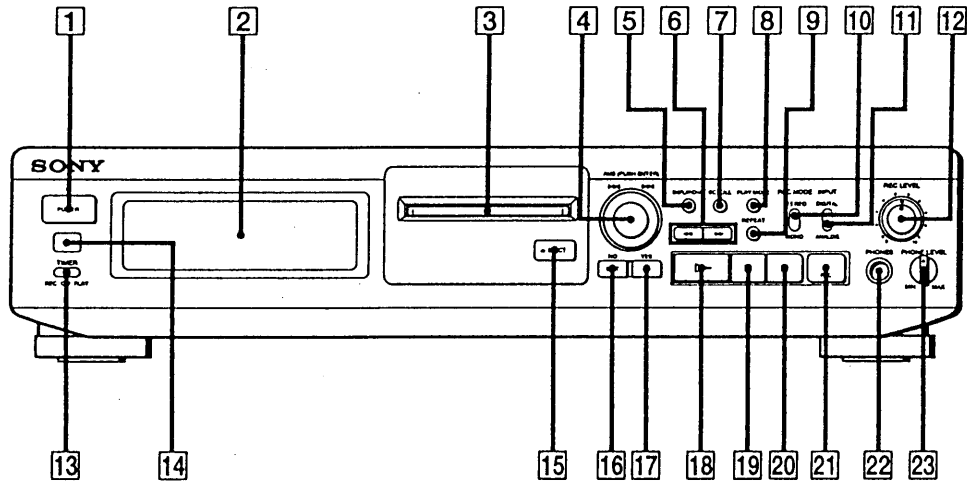

- 1 POWER switch
- 2 Display window
- 3 MD disc tray
- 4 AMS knob
- 5 DISPLAY/CHAR button
- 6 ◀▶ (REW/FF) buttons
- 7 SCROLL button
- 8 PLAY MODE button
- 9 REPEAT button
- 10 REC MODE switch
- 11 INPUT switch
- 12 REC LEVEL knob

- 13 Timer switch
- 14 Remote sensor
- 15 ⏏ EJECT button
- 16 EDIT/NO button
- 17 YES button
- 18 ▶ (Play) button
- 19 ⏸ (Pause) button
- 20 ■ (Stop) button
- 21 ● REC (Rec) button
- 22 PHONES jack
- 23 PHONE LEVEL knob

Basic Operations

Recording on an MD

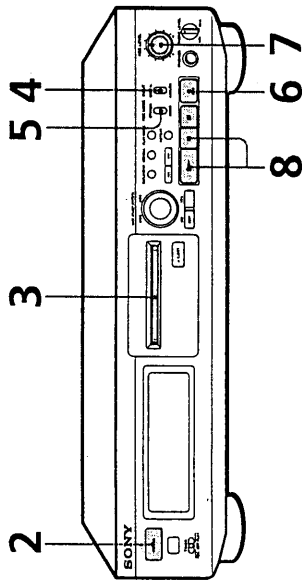

- 1 Turn on the amplifier and play the program source you want to record.
- 2 Press POWER. The POWER indicator changes from red to green.
- 3 Insert a recordable MD.

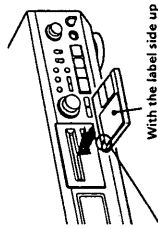

With the arrow pointing this way
With the label side up

If the MD has a recorded material on it, the deck will automatically start recording from the end of the last recorded track.

- 4 Set INPUT to the corresponding input connector.

To record through	Set INPUT to
DIGITAL IN	DIGITAL
LINE (ANALOG) IN	ANALOG
- 5 Set REC MODE to the mode you want to record in.

To record in	Set REC MODE to
Stereo sound	STEREO
Monaural sound*	MONO

Monitor audio during recording
Even if you set REC MODE to MONO, the monitor signal does not become monaural.

* In the monaural recording, you can record about two times longer than in the stereo recording.

When "TOC" flashes in the display the deck is currently updating the Table Of Contents (TOC). Do not move the deck or pull out the AC power cord. Changes to an MD made through recording are saved only when you update the TOC by ejecting the MD or changing the deck to standby by pressing POWER.

- 6 Press ● REC. The deck becomes ready to record.
- 7 When recording the analog input signal, adjust the recording level with REC LEVEL. The fourth dot is satisfactory for most purposes. For details, refer to "Adjusting the Recording Level" on page 11.
- 8 Press ▷ or II. Recording starts.
- 9 Start playing the program source.

Do not disconnect the deck from the power source immediately after recording

If you do, recorded material may not be saved to the MD. To save the material, after recording, press EJECT to take out the MD or change the deck to standby by pressing POWER. "TOC" will flash in the display at this time. After "TOC" stops flashing and goes out, you can pull out the AC power cord.

- To
- | | |
|------------------|--|
| Stop recording | Press |
| Pause recording* | II. Press the button again or press ▷ to resume recording. |
| Take out the MD | EJECT after stopping recording |

* Whenever you pause recording, the track number increases by one. For example, if you paused recording while recording on track 4, the track number increases by one and recording continues on the new track when restarted.

To protect an MD against accidental erasure

To make it impossible to record on an MD, slide the tab in the direction of arrow, opening the slot. To allow recording, close the slot.

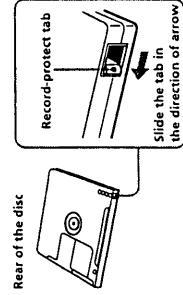

Note
If you switch REC MODE during recording or recording pause, recording stops.

Basic Operations

Playing an MD

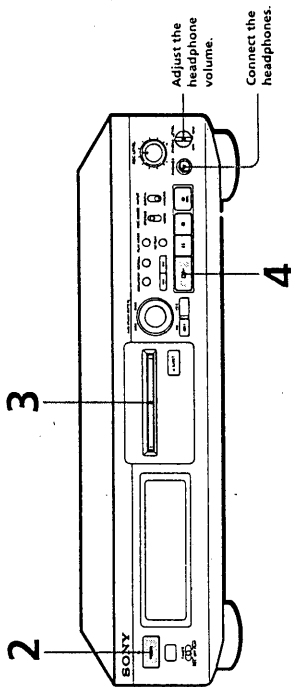

1 Turn on the amplifier and set the source selector to the position for MD deck.

2 Press POWER. The POWER indicator changes from red to green.

3 Insert an MD.

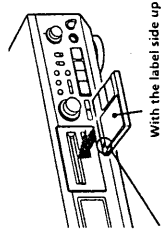

With the arrow pointing this way

4 Press \blacktriangleleft . The deck starts playing. Adjust the volume on the amplifier.

To	Do the following:
Stop playing	Press \blacksquare .
Pause playing	Press \blacktriangleright . Press the button again or press \blacktriangleleft to resume playing.
Go to the next track	Turn AMS clockwise (or press \blacktriangleright on the remote).
Go to the preceding track	Turn AMS counterclockwise (or press \blacktriangleleft on the remote).
Take out the MD	Press \blacktriangle EJECT after stopping playing.

To use headphones
Connect them to PHONES jack. Use PHONE LEVEL to adjust the volume.

Recording on MDs

Notes on Recording

- If "Protected" appears in the display The MD is record-protected. Close the slot to record on the disc (see "To protect an MD against accidental erasure" on page 7).
- If "Din Unlock" flashes in the display The digital program source is not connected as you set with INPUT in Step 4 on page 6.
- To continue, connect the program source properly.
- The program source is not on.
- Turn on the program source.

Depending on source being recorded, track numbers are marked in following ways:

- When recording from a CD or MD with INPUT at DIGITAL and the source connected through DIGITAL IN: The deck automatically marks track numbers in the same sequence as the original. If, however, a track is repeated two or more times (e.g. by single-track repeat play) or two or more tracks with the same track number (e.g. from different MDs or CDs) are played, the track or tracks are recorded as part of a single, continuous track with a single track number.
- If the source is an MD, track numbers may not be marked for tracks of less than 4 seconds.
- When recording from source connected through LINE (ANALOG IN with INPUT at ANALOG, and "LEVEL-SYNC" does not light up (see "Marking Track Numbers While Recording" on page 12) or when recording from DAT or satellite broadcast connected through DIGITAL IN with INPUT at DIGITAL: The source will be recorded as a single track. You can divide the track afterwards using the Divide Function (see "Dividing Recorded Tracks" on page 24) or mark track numbers during recording by using the Track Marking Function on page 12.
- If "LEVEL-SYNC" appears in the display, the deck automatically marks track numbers when recording analog source or digital recording of DAT or satellite broadcasts (see "Marking track numbers automatically" on page 12).
- When recording from DAT or satellite broadcasts with INPUT at DIGITAL, the deck automatically marks a track number whenever the sampling frequency of the input signal changes.

When "TOC" flashes in the display The deck is currently updating the Table Of Contents (TOC). Do not move the deck or pull out the AC power cord. Changes to an MD made through recording are saved only when you update the TOC by ejecting the MD or changing the deck to standby by pressing POWER.

The MD deck uses the SCMS (Serial Copy Management System on page 33) MDs recorded through digital input connector cannot be copied onto other MDs or DAT tapes through the digital output connector.

When recording digital signals that have been emphasized (in the higher frequencies) The signal is automatically de-emphasized (with attenuation proportional to the degree of emphasis) and the level of the de-emphasized signal is indicated on the peak level meters.

When the deck is recording or in recording pause, digital signals input through DIGITAL IN are output to DIGITAL OUT with the same sampling rate. To change the digital input signal to another sampling rate for output (without recording it to an MD), use Input Monitor Function (see page 10).

Useful Tips for Recording

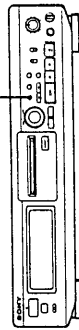

Checking the remaining recordable time on the MD

- When you press DISPLAY/CHAR while recording, the remaining recordable time on the MD appears.
- When you press DISPLAY/CHAR repeatedly while the deck is stopped, the display changes as follows: total recorded time, remaining recordable time on the MD, disc name (see page 16).

(Continued)

Monitoring the input signal (Input Monitor)

Before starting recording, you can monitor the selected input signal through the deck's output connectors.

- 1 Press **EJECT** to remove the MD.
- 2 Set **INPUT** according to the input signal you want to monitor.

When INPUT is at ANALOG
The analog signal input through **LINE (ANALOG) IN** is output to **DIGITAL OUT** after A/D conversion, and then to the **LINE (ANALOG) OUT** connectors and **PHONES** jack after D/A conversion.

When INPUT is at DIGITAL
The digital signal input through **DIGITAL IN** is output to **DIGITAL OUT**, and then to the **LINE (ANALOG) OUT** connectors and **PHONES** jack after D/A conversion.

Note

Even if you set **REC MODE** to **MONO**, the monitor signal does not become monaural.

- 3 Press **REC**.
If **INPUT** is at **ANALOG**, "AD-DA" appears in the display.
If **INPUT** is at **DIGITAL**, "DA" appears in the display.

If "Auto Cut" appears in the display (Auto Cut)

There has been no sound input for 30 seconds while **INPUT** is set to **DIGITAL** and the source is connected through **DIGITAL IN**. The 30 seconds of silence are replaced by a blank of about 3 seconds and the deck changes to recording pause.

You can turn off the Auto Cut Function
For details, see "If "Smart Space" appears in the display" below.

If "Smart Space" appears in the display (Smart Space)

There has been an extended silence of 4 to 30 seconds in length when **INPUT** is set to **DIGITAL** and the source is connected through **DIGITAL IN**. The silence is replaced with a blank of about 3 seconds and the deck continues recording.

To turn off the Smart Space Function and Auto Cut Function

- 1 During recording pause, press **EDIT/NO** repeatedly until "S. Space ?" appears in the display.
- 2 Press **YES**.
- 3 Press **EDIT/NO** to display "S. Space OFF."

To turn on the Smart Space Function and Auto Cut Function again

- 1 During recording pause, press **EDIT/NO** repeatedly until "S. Space ?" appears in the display.
- 2 Press **YES** twice to display "S. Space ON."

Notes

- When you turn off the Smart Space Function, the Auto Cut Function is also turned off automatically.
- The Smart Space Function and Auto Cut Function are factory set to on.
- The Smart Space Function does not affect the order of the track numbers being recorded, even if the blank space occurs in the middle of a track.
- If you turn off the deck or disconnect the AC power cord, the deck will recall the last setting (on or off) of the Smart Space and Auto Cut Functions the next time you turn on the deck.

Playing back tracks just recorded

Do this procedure to immediately play back tracks that have just been recorded.

Press **▷** immediately after stopping recording.
Playback starts from the first track of the material just recorded.

To play from the first track of the MD after recording

- 1 Press **■** again after stopping recording.
- 2 Press **▷**.
Playback starts from the first track of the MD.

Recording Over Existing Tracks

Follow the procedure below to record over existing material just as you would on an analog cassette tape.

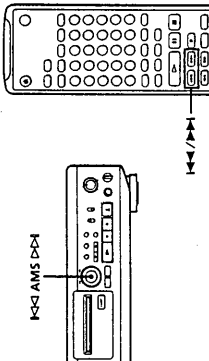

- 1 Do Steps 1 to 5 in "Recording on an MD" on page 6.
- 2 Turn **AMS** (or press **◀** or **▶**) until the number of the track to be recorded over appears.
- 3 To record from the start of the track, continue from Step 6 in "Recording on an MD" on page 7.

While "TRACK" flashes in the display

The deck is recording over an existing track, and stops flashing when it reaches the end of the recorded portion.

To record from the middle of the track

- 1 After Step 2 above, press **▷** to start playback.
- 2 Press **■** where you want to start recording.
- 3 Continue from Step 6 in "Recording on an MD" on page 7.

Note

You cannot record from the middle of an existing track when the "PROGRAM" or "SHUFFLE" is on.

Adjusting the Recording Level

When recording with **INPUT** at **ANALOG** and the signal input through **LINE (ANALOG) IN** jacks, use **REC LEVEL** to adjust the recording level before starting recording.

You cannot adjust the recording level during digital recording.

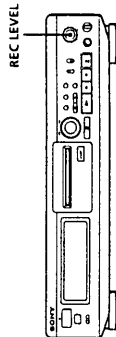

- 1 Do Steps 1 to 6 in "Recording on an MD" on pages 6 and 7.
- 2 Play the portion of the program source with the strongest signal level.
- 3 While monitoring the sound, turn **REC LEVEL** to adjust the recording level so that the peak level meters reach their highest point without turning on the **OVER** indication. Occasional lighting of "OVER" is acceptable.

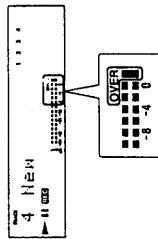

- 4 Stop playing the program source.

- 5 To start recording, do the procedure starting from Step 8 in "Recording on an MD" on page 7.

Marking Track Numbers While Recording (Track Marking)

You can mark track numbers either manually or automatically. By marking track numbers at specific points, you can quickly locate the points later using the AMS Function or Editing Functions.

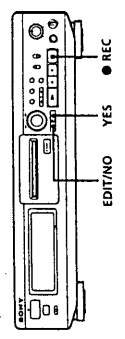

Marking track numbers manually (Manual Track Marking)

You can mark track numbers at any time while recording on an MD.

Press ● REC at the place you want to add a track mark while recording.

Marking track numbers automatically (Automatic Track Marking)

The deck adds track marks differently in the following cases:

- When recording from CDs or MDs with INPUT at DIGITAL and the source connected through DIGITAL IN: The deck marks track numbers automatically. When you record from a CD or MD, the track numbers are marked as they are found on the original.
- When recording with INPUT at ANALOG and the source connected through LINE (ANALOG) IN, or when recording from DAT or satellite broadcasts with INPUT at DIGITAL and the DAT or satellite broadcast connected through DIGITAL IN: The deck marks a new track number whenever the signal level drops and rises to a certain point* (Automatic Track Marking). If "LEVEL-SYNC" does not light up, set the LevelSync to ON as follows:

- 1 Press EDIT/NO to display "LevelSync ?" during recording or recording pause.
- 2 Press YES twice to display "LevelSync ON." "LEVEL-SYNC" appears in the display.

To cancel Automatic Track Marking

- 1 Press EDIT/NO during recording or recording pause. "LevelSync ?" appears in the display.
 - 2 Press YES.
 - 3 Press EDIT/NO.
- * "LevelSyncOFF" appears in the display.
- The signal level must remain low for 2 or more seconds before a new track number is marked.

When you want to mark track numbers after you've finished recording
Use the Divide Function (see "Dividing Recorded Tracks" on page 24).

NOTE
If you turn off the deck or disconnect the AC power cord, the deck will recall the last setting (LevelSync on or off) of the Automatic Track Marking Function the next time you turn on the deck.

Starting Recording With 2 Seconds of Prestored Audio Data (Time Machine Recording)

When recording from an FM or satellite broadcast, the first few seconds of material are often lost due to the time it takes you to ascertain the contents and press the record button. To prevent the loss of this material, the Time Machine Recording Function constantly stores 2 seconds of the most recent audio data in a buffer memory so that when you begin recording the program source, the recording actually begins with the 2 seconds of audio data stored in the buffer memory in advance, as shown in the illustration below:

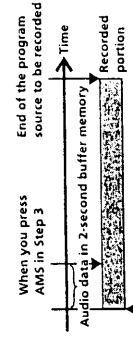

Beginning of the program source to be recorded

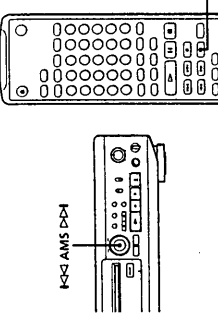

- 1 Do Steps 1 to 6 in "Recording on an MD" on pages 6 and 7. The deck changes to recording pause.

- 2 Start playing the program source you want to record. The most recent 2 seconds of audio data is stored in the buffer memory.

- 3 Press AMS (or T.REC) to start Time Machine Recording. Recording of the program source starts with the 2 seconds of audio data stored in the buffer memory.

To stop Time Machine Recording
Press ■

Note
The deck starts storing audio data when the deck is in recording pause and you start playing the program source. With less than 2 seconds of playing of the program source and audio data stored in the buffer memory, Time Machine Recording starts with less than 2 seconds of audio data.

Synchro-Recording With Audio Equipment of Your Choice

By using the MUSIC SYNC button on the remote, you can automatically start recording in sync with the signal input from the program source through the LINE (ANALOG) IN jacks or the DIGITAL IN connector (Music Synchro-Recording). The method of marking track numbers differs, depending on the program source being recorded and how the deck is connected to the program source. (See "Notes on Recording" on page 9.)

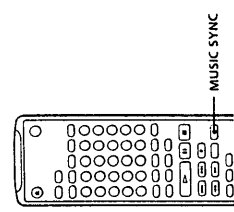

- 1 Do Steps 1 to 5 in "Recording on an MD" on page 6.

- 2 Press MUSIC SYNC. The deck changes to recording pause.

- 3 Start playing the program source you want to record. The deck starts recording automatically.

To stop Music Synchro-Recording
Press ■

Note
When Music Synchro-Recording, the Smart Space Function and the Auto Cut Function turn on automatically regardless of their setting (ON or OFF) and type of input (digital or analog).

Synchro-Recording With a Sony CD Player II

By connecting your deck to a Sony CD player or Hi-Fi Component System, you can easily dub CDs onto MDs using the CD synchro buttons on the remote. If your deck is connected to a Sony CD player by a digital input cable, track numbers are automatically marked as appear on the original regardless of whether "LevelSync ON" or "LevelSyncOFF" is selected. If your deck is connected to a Sony CD player by audio connecting cords through LINE (ANALOG) IN, track numbers are automatically marked when you select "LevelSync ON" (see "Marking Track Numbers While Recording" on page 12).

As the same remote controls both the CD player and the deck, you may have trouble operating both units if they are far from each other. If you do, place the CD player close to this deck.

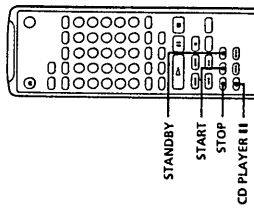

- 1 Set the source selector on the amplifier to CD.
- 2 Do Steps 2 to 5 in "Recording on an MD" on page 6 to prepare the deck for recording.
- 3 Insert a CD into the CD player.
- 4 Select the playback mode (Shuffle Play, Program Play, etc.) on the CD player.
- 5 Press STANDBY. The CD player pauses for playing and the deck pauses for recording.

- 6 Press START. The deck starts recording and the CD player starts playback. The track number and elapsed recording time of the track appear in the display.

If the CD player does not start playing Some CD player models may not respond when you press START on the remote of the deck. Press II on the remote of the CD player instead.

- 7 Press STOP to stop synchro-recording.

To pause recording Press STANDBY or CD PLAYER II. To restart recording, press START or CD PLAYER II. A new track number is marked each time you pause recording.

You can use the remote of the CD player during synchro-recording

When you press II, the CD player stops and the deck pauses for recording. When you press II, the CD player pauses and the deck pauses for recording. To restart synchro-recording, press II.

You can change CDs during synchro-recording

- 1 Press II on the remote of the CD player. The deck pauses for recording.
- 2 Change the CD.
- 3 Press II on the remote of the CD player. Synchro-recording restarts.

You can also do synchro-recording with a Sony video CD player

Using the procedure for synchro-recording with a Sony CD player, you can do synchro-recording with a Sony video CD player also. To select the video CD player, press button number 2 while pressing down the POWER button before starting the procedure.

To select the CD player again, press button number 1 while pressing down the POWER button. The deck is factory set to a CD player for synchro-recording.

You can check the remaining recordable time on the MD Press DISPLAY (see page 16).

Recording on an MD Using a Timer

By connecting a timer (not supplied) to the deck, you can start and stop recording operations at specified times. For further information on connecting the timer and setting the starting and ending times, refer to the instructions that came with the timer.

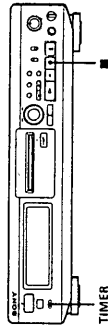

- 1 Do Steps 1 to 7 in "Recording on an MD" on pages 6 and 7.

- 2 If you want to specify the time for the start of recording, press II.

If you want to specify the time for the end of recording, do Steps 8 and 9 of "Recording on an MD" on page 7.

- 3 If you want to specify the time for both start and end of recording, press II.

- 4 Set TIMER on the deck to REC.

- 5 Set the timer as required.

When you have set the time for the start of recording, I = deck turns off. When the specified time arrives, the deck turns on and starts recording.

When you have set the time for the end of recording, recording continues. When the specified time arrives, the deck stops recording and turns off.

When you have set the time for both the start and end of recording, the deck turns off. When the starting time arrives, the deck turns on and starts recording. When the ending time arrives, the deck stops recording and turns off.

- 5 After you have finished using the timer, set TIMER on the deck to OFF. Then place the deck in standby status by plugging the AC power cord of the deck into a wall outlet or set the timer to continuous operation.

- If TIMER is left at REC, the deck will automatically start recording the next time you turn the deck on.
- If you do not change the deck to standby status for more than a month after timer recording has finished, the recorded contents may disappear.

Make sure to change the deck to standby status within a month after timer recording is completed

The TOC on the MD is updated and recorded contents are written to it: MD when you turn the deck on. If the recorded contents have disappeared, "STANDBY" flashes when you turn the deck on.

Notes

- During timer recording, new material is recorded from the end of the recorded portion on the MD.
- Material recorded during timer recording will be saved to the disc the next time you turn the deck on. "TOC" will flash in the display at that time. Do not move the deck or pull out the AC power cord while "TOC" is flashing.
- Timer recording will stop if the disc becomes full.

Using the Display

You can use the display to check disc and track information such as the total track number, total playing time of the tracks, remaining recordable time of the disc and disc name.

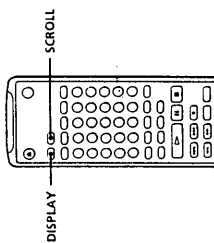
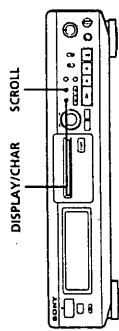

Checking the total track number, total disc playing time, remaining recordable time of the disc and the title of the disc

Each time you press DISPLAY/CHAR (or DISPLAY) while the deck is stopped, you can change the display as follows:

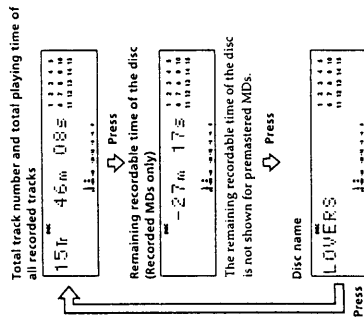

When you insert an MD, the disc name, total number of tracks, and total disc playing time appear in the display as follows:

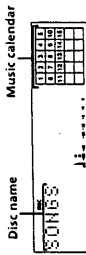

Total number of tracks

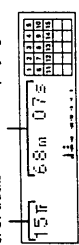

The disc name appears, followed by the total number of tracks (Tr) and total disc playing time.

A music calendar showing all the track numbers appears within a grid if the MD is a premastered disc, or without a grid if the MD is a recordable disc. If the total track number exceeds 25, ▶ appears to the right of number 25 in the music calendar.

To label a recordable disc and its tracks, see "Labeling Recordings" on page 26.

Note

When you insert a new MD or turn off the deck and turn it on again, the last item displayed will reappear. If, however, you disconnect the AC power cord, the display will show the total track number and total playing time of all recorded tracks the next time you turn on the deck, no matter what the last display was.

Checking remaining time and the title of a track

Each time you press DISPLAY/CHAR (or DISPLAY) while playing an MD, you can change the display as shown below. The track numbers in the music calendar disappear after they are played.

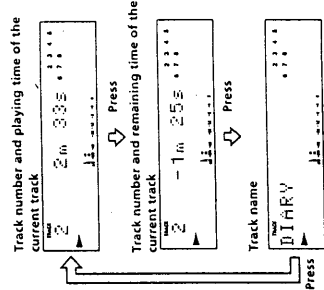

If no title is recorded, "No Name" appears, followed by the elapsed playing time.

You can check the track name at any time while playing an MD.

Press SCROLL. Since the display shows up to 12 characters at a time, press SCROLL again to see the rest of the track title if the title has 13 characters or more. Press SCROLL again to pause scrolling, and again to continue scrolling.

Locating a Specific Track

You can quickly locate any track while playing a disc by using AMS (Automatic Music Sensor), ◀▶ and ▶▶-1, number buttons or MISCAN on the remote.

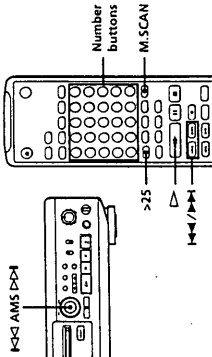

To locate	Do the following:
The next or succeeding tracks	During playback, turn AMS clockwise or press ▶▶ repeatedly until you find the track.
The current or preceding tracks	During playback, turn AMS counterclockwise or press ◀▶ repeatedly until you find the track.
A specific track directly	Press number buttons to enter the track number.
A specific track by AMS	1 Turn AMS until the track number you want to locate appears while the deck is stopped. (The track number is flashing) 2 Press AMS or ▶▶.
By scanning each track for 6 seconds (music scan)	1 Press MISCAN before you start playing. 2 When you find the track you want, press ▶▶ to start playing.

You can extend the playing time during music scan

While the deck is stopped, press MISCAN repeatedly until the playing time you want (6, 10 or 20 seconds) appears in the display. Each press changes the time in order of 6 to 20, then from 6 again.

To pause playing at the beginning of a track

Turn AMS (or press ◀▶ or ▶▶) after pausing playback.

To go quickly to the beginning of the last track

Turn AMS counterclockwise (or press ◀▶) while the display shows the total track number and total disc playing time, remaining recordable time of the disc, or disc name (see page 16).

Locating a Particular Point in a Track

You can also use **◀▶** and **▶▶** to locate a particular point in a track during playback or playback pause.

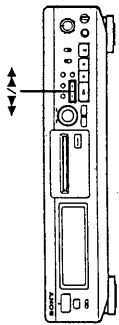

To locate a point
While monitoring the sound

Press
▶▶ (forward) or ◀▶ (backward) and keep pressing until you find the point.

Quickly by observing the display during playback pause

▶▶ or ◀▶ and keep pressing until you find the point. There is no sound output during this operation.

- Notes**
- If the disc reaches the end while you are pressing ▶▶ during playback pause, "OVER" appears in the display. Press ◀▶ (or ▶▶) or turn AMS counterclockwise to go back.
 - If the disc reaches the end while you are pressing ◀▶ during sound monitoring, the deck stops.
 - Tracks that are only a few seconds long may be too short to scan using the search function. For such tracks, it is better to play the MD at normal speed.

Playing Tracks Repeatedly

You can play tracks repeatedly in any play mode.

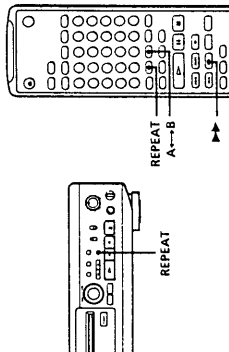

Press REPEAT.
"REPEAT" appears in the display.
The deck repeats the tracks as follows:

When the MD is played in	The deck repeats
Normal play (page 8)	All the tracks
Shuffle Play (page 19)	All the tracks in random order
Program Play (page 20)	The same program

To cancel repeat play
Press REPEAT several times until "REPEAT" disappears. The deck returns to the original playing mode.

Repeating the current track

While the track you want to repeat is playing in normal play, press REPEAT several times until "REPEAT 1" appears in the display.

Repeating a specific portion (A-B Repeat)

You can play a specific portion of a track repeatedly. This might be useful when you want to memorize lyrics.
Note that you can only repeat a portion within the boundaries of a single track.

- 1 While playing a disc, press A←B at the starting point (point A) of the portion to be played repeatedly. "REPEAT A-" flashes in the display.
- 2 Continue playing the track or press ▶▶ until you reach the ending point (point B), then press A←B again. "REPEAT A-B" lights continuously. The deck starts to play the specified portion repeatedly.

To cancel A-B Repeat
Press REPEAT or ■.

Setting new starting and ending points
You can repeat the portion immediately after the currently specified portion by changing the starting and ending points.

- 1 Press A←B while "REPEAT A-B" appears. The current ending point B becomes the new starting point A and "REPEAT A-" flashes in the display.
- 2 Continue playing the track or press ▶▶ until you reach the new ending point (point B), then press A←B again. "REPEAT A-B" lights continuously and the deck starts playing repeatedly the newly specified portion.

Note
If you turn off the deck or disconnect the AC power cord, the deck will recall the last setting of the Repeat function the next time you turn on the deck.

The A-B Repeat settings, however, are lost.

Playing in Random Order (Shuffle Play)

You can have the deck "shuffle" tracks and play them in random order.

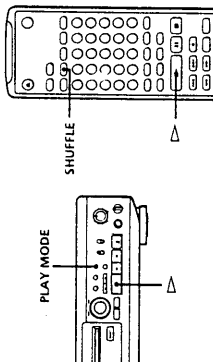

- 1 Press PLAY MODE repeatedly (or SHUFFLE once) until "SHUFFLE" appears in the display when the deck is stopped.

- 2 Press ▶▶ to start Shuffle Play. "◀▶" appears in the display while the deck is "shuffling" the tracks.

To cancel Shuffle Play
Press PLAY MODE repeatedly (or CONTINUE once) until "SHUFFLE" disappears.

You can specify tracks during Shuffle Play

- To play the next track, turn AMS clockwise (or press ▶▶).
- To play from the beginning of the current track again, turn AMS counterclockwise (or press ◀▶). You must use AMS (or ▶▶) to go to tracks that have already been played.

- Set the timer as required.
 - When you have set the time for the start of playback, the deck turns off. When the specified time arrives, the deck turns on and starts playing.
 - When you have set the time for the end of playback, playback continues. When the specified time arrives, the deck stops playing and turns off.
 - When you have set the time for both the start and end of playback, the deck turns off. When the starting time arrives, the deck turns on and starts playing. When the ending time arrives, the deck stops playing and turns off.
- After you have finished using the timer, set **TIMER** on the deck to **OFF**.

Note

You can select **Program Play** in Step 2. Note, however, that programs eventually fade away when the standby status is off, and therefore if you set the time to fit in the future, the program may be gone when the specified time arrives. If this has occurred, the deck enters normal play mode at the specified time and the tracks play in consecutive order.

Notes on Editing

- You can edit the recorded tracks after recording, using the following functions:
- Erase Function allows you to erase recorded tracks simply by specifying the corresponding track number.
 - Divide Function allows you to divide tracks at specified points so that you can quickly locate those points afterwards, using the **AMS** function.
 - Combine Function allows you to combine two consecutive tracks into one.
 - Move Function allows you to change the order of tracks by moving a specific track to a track position you want.
 - Title Function allows you to create titles for your recorded MDs and tracks.

If "Protected" appears in the display

The deck could not edit because the record-protect slot on the MD is open. Edit after closing the slot.

Erasing Recordings (Erase Function)

Do the procedures below to erase following:

- A single track
 - All tracks
 - Parts of a track
- Note, however, that once erased, MD data cannot be recovered.**

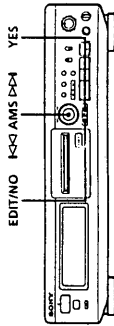

Erasing a single track

You can erase a track simply by specifying the respective track number. When you erase a track, the total number of tracks on the MD decreases by one and all tracks following the erased one are renumbered. Since erasing merely updates the **TOC**, there is no need to record over material.

To avoid confusion when erasing multiple tracks, you should proceed in order of high to low track number to prevent the renumbering of tracks that have not been erased yet.

Example: Erasing B

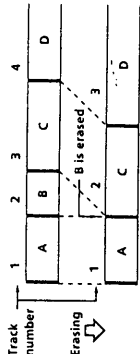

- Turn **AMS** until the track number you want to erase appears in the display.
- Press **EDIT/NO** repeatedly until "Erase ?" appears in the display. The track number you selected starts flashing in the music calendar.

- Press **YES**. When the track selected in Step 1 has been erased, "Complete" appears for a few seconds and the total number of tracks in the music calendar decreases by one. If you erase a track during playback, the track following the deleted track begins playing afterwards.

- Repeat Steps 1 to 3 to erase more tracks.

To cancel the Erase Function Press **EDIT/NO**, or turn **AMS** to change the track number.

Note
If "Erase?" appears in the display, the track was recorded or edited on another MD deck and is record-protected. If this indication appears, press **YES** to erase the track.

Erasing all tracks on an MD

Erasing a recordable MD deletes the disc name, all recorded tracks, and titles (see page 29).

- While the deck is stopped, press **EDIT/NO** repeatedly until "All Erase ?" appears in the display.
- Press **YES**. All tracks in the music calendar start flashing.
- Press **YES** again. When the disc name, all recorded tracks, and titles on the MD have been erased, "Complete" appears for a few seconds and the music calendar disappears.

To cancel the Erase Function Press **EDIT/NO** or **■**.

Erasing a part of a track

By using the **Divide** (see page 24), **Erase** (see page 22) and **Combine** (see page 25) Functions, you can erase specific portions of a track.

Example: Erasing a part of track A

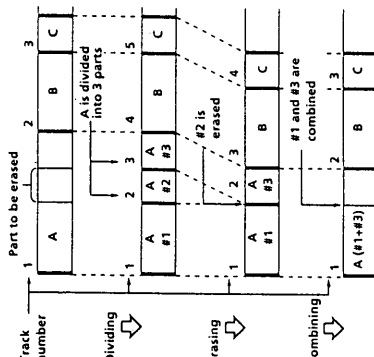

Dividing Recorded Tracks (Divide Function)

With the Divide Function you can assign a track number at places that you want to randomly access afterwards. Use this function to add tracks to MDs recorded from an analog source (and therefore contain no track numbers), or to divide an existing track into multiple portions. When you divide a track, the total number of tracks on the MD increases by one and all tracks following the divided track are renumbered.

Example: Dividing track 2 to create a new track for C

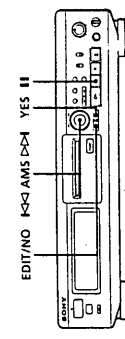
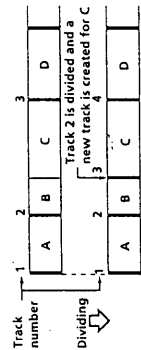

- 1 While playing the MD, press **II** at the point where you want to create a new track. The deck pauses playing.
- 2 Press EDIT/NO repeatedly until "Divide ?" appears in the display.
- 3 Press YES to divide the track. "Rehearsal" alternates with "Position ok?" in the display, the track to be divided starts flashing in the music calendar, and the starting portion of the new track begins playing repeatedly.
- 4 If the starting position is incorrect, press EDIT/NO. (If it is correct, go to Step 7.)

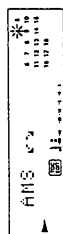

- 5 While monitoring the sound, turn AMS to find the starting position of the new track. The starting portion of the new track is played back repeatedly. "Rehearsal" alternates with "Position ok?" in the display. The starting position can be moved within a maximum range of -128 to +127 steps of about 0.06 second each within a track.
- 6 If the starting position is still incorrect, repeat Step 5 until it is correct.
- 7 Press YES or AMS when the position is correct. When the track has been divided, "Complete" appears for a few seconds and the newly created track begins playing. The new track will have no track title even if the original track was labeled.

To cancel the Divide Function Press **■**.

You can undo a track division Combine the tracks again (see "Combining Recorded Tracks" on page 25) then redivide the tracks if necessary.

You can divide a track while recording Use the Track Marking Function (see page 12).

Combining Recorded Tracks (Combine Function)

Use the Combine Function while the deck is stopped, playing or in pause to combine consecutive tracks on a recorded MD. This function is useful for combining several songs into a single medley, or several independently recorded portions into a single track. When you combine two tracks, the total number of tracks decreases by one and all tracks following the combined tracks are renumbered.

Example: Combining B and C

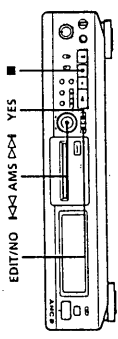
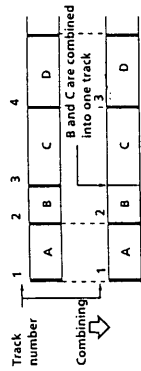

- 1 Turn AMS until the second track of the two to be combined appears. For example, when combining tracks 3 and 4, turn AMS until 4 appears.
- 2 Press EDIT/NO repeatedly until "Combine ?" appears in the display.
- 3 Press YES. "Rehearsal" alternates with "Track ok?" in the display. The place where the two tracks will join (i.e., the end of the first track and the beginning of the second track) repeatedly plays back and the respective track number flashes in the music calendar.
- 4 If the track is the wrong one, press EDIT/NO or **■**, then start from Step 1 again.
- 5 If the place is correct, press YES. When the tracks have been combined, "Complete" appears for a few seconds and the total number of tracks in the music calendar decreases by one. If both of the combined tracks have track titles, the title of the second track is erased.

To cancel the Combine Function Press EDIT/NO or **■**.

You can undo a track combination Divide the tracks again (see "Dividing Recorded Tracks" on page 24), then repeat the combine function with the correct tracks if necessary.

Note If "Sorry" appears in the display, the tracks cannot be combined. This sometimes happens when you've edited the same track many times, and is due to a technical limitation of the MD system, not a mechanical error.

Moving Recorded Tracks (Move Function)

Use the Move Function to change the order of any track. After you move a track, the track numbers between the new and old track positions are automatically renumbered.

Example: Moving track C to track position 2

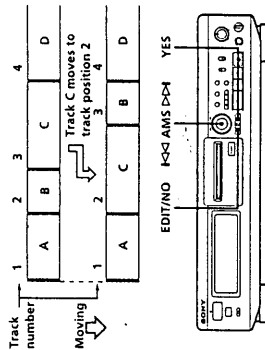

- 1 Turn AMS until the track number you want to move appears in the display.
- 2 Press EDIT/NO repeatedly until "Move ?" appears in the display.
- 3 Press YES:
The track number to be moved and the new track position appears.

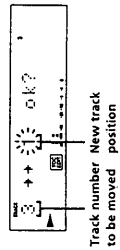

- 4 Turn AMS until the new track position appears.

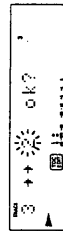

- 5 Press YES or AMS.

After you have moved the track, "Complete" appears for a few seconds and the moved track begins playing back if the deck is in playback mode.

To cancel the Move Function
Press EDIT/NO or ■.

Labeling Recordings (Title Function)

You can create titles for your recorded MDs and tracks. Titles — which may consist of uppercase and lowercase letters, numbers and symbols for a maximum of about 1,700 characters per disc — appear in the display during MD operation.

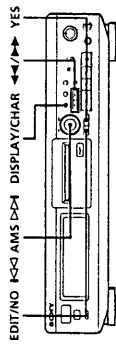

Use the following procedure to label a track or an MD. You can label a track while it is playing, pausing or recording. If the track is playing or recording, be sure to finish labeling before the track ends. If the track ends before you've completed the labeling procedure, the characters already entered are not recorded and the track will remain unlabeled.

- 1 Press EDIT/NO repeatedly until "Name in ?" appears in the display, then do the following:

To label A track	Make sure that the deck is playing, pausing, recording the track to be labeled, or stopped after locating the track to be labeled
An MD	Stopped with no track number appearing in the display

- 2 Press YES.

A flashing cursor appears in the display.



- 3 Press DISPLAY/CHAR to select the character type as follows:

To select	Press DISPLAY/CHAR repeatedly until
Uppercase letters	"A" appears in the display
Lowercase letters	"a" appears in the display
Numbers	"0" appears in the display

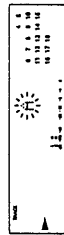

- 4 Turn AMS to select the character.

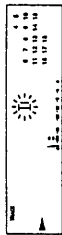

The selected character flashes. Letters, numbers, and symbols appear in sequential order as you turn AMS. You can use the following symbols in titles:
! " # \$ % & ' () * + , - . / : ; < = > ? @ _ `

You can press DISPLAY/CHAR to change the character type at any time during Step 4 (see Step 3).

- 5 Press AMS to enter the selected character. The cursor shifts rightward and waits for the input of the next character.



- 6 Repeat Steps 3 to 5 until you have entered the entire title.

If you entered the wrong character Press ← or → until the character to be corrected starts flashing, and repeat Steps 3 to 5 to enter the correct character.

To erase a character

Press ← or → until the character to be erased starts flashing, then press EDIT/NO.

To enter a space
Press AMS or → while the cursor is flashing.

- 7 Press YES.

This completes the labeling procedure and the title appears on the left side of the display.

To cancel labeling
Press ■.

Note
You cannot label a track or an MD while you are recording over an existing track.

(Continued)

Labeling tracks and MDs with the remote

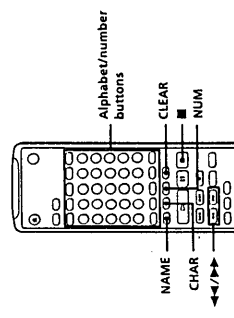

- Press NAME repeatedly until a flashing cursor appears in the display, then do the following:

To label	Make sure that the deck is
A track	Playing, pausing, recording the track to be labeled, or stopped after locating the track to be labeled
An MD	Stopped with no track number appearing in the display

- Select the character type as follows:

To select	Press
Uppercase letters	CHAR repeatedly until "Selected ABC" appears in the display
Lowercase letters	CHAR repeatedly until "Selected abc" appears in the display
Numbers	NUM repeatedly until "Selected 123" appears in the display

- Enter one character at a time. After you enter a character, the cursor shifts rightward and waits for the input of the next character.

- Repeat Steps 2 and 3 until you have entered the entire title.

If you entered the wrong character Press ← or → until the character to be corrected starts flashing. Press CLEAR to erase the incorrect character, then enter the correct one.

- Press NAME again. The entered title appears on the left side of the display window after the label has been recorded.

To cancel labeling Press ■.

Changing an existing title

- Press NAME, then do the following:

To change	Make sure that the deck is
A track title	Playing, pausing the track-whose title is to be changed, or stopped after locating the track-whose title is to be changed
A disc name	Stopped with no track number appearing in the display

- Keep pressing CLEAR (or EDIT/NO on the deck) until the current title is erased.

- Enter the new title. Do Steps 3 to 6 of "Labeling Recordings" on page 26, or Steps 2 to 4 of "Labeling tracks and MDs with the remote" on page 28.

- Press NAME.

Erasing all titles on a disc (Name Erase Function)

Use this function to erase all titles on an MD simultaneously. Note that once erased, titles cannot be recovered.

- Press EDIT/NO repeatedly while the deck is stopped until "All Erase ?" appears in the display.
- Press EDIT/NO again. "Name Erase ?" appears in the display.
- Press YES. All titles are erased.

To cancel the Name Erase Function Press ■.

You can erase all recorded tracks and titles See "Erasing all tracks on an MD" on page 23.

Undoing the Last Edit (Undo Function)

You can use the Undo Function to cancel the last edit and restore the contents of the MD to the condition that existed before editing was done. Note, however, that you cannot undo an edit if you do any of the following after the edit:

- Press the REC button on the front panel.
- Press the button, the MUSIC SYNC button, or the CD-SYNC STANDBY button on the remote.
- Update the TOC by turning off the power or ejecting the MD.
- Disconnect the AC power cord.

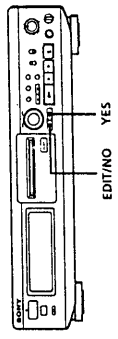

- With the deck stopped and no track number appearing in the display, press EDIT/NO repeatedly until "Undo ?" appears in the display. "Undo ?" does not appear if no editing has been done.

- Press YES. One of the following messages appears in the display, depending on the type of editing to be undone:

Editing done:	Message:
Erasing a single track	"Erase Undo ?"
Erasing all tracks on an MD	"Divide Undo ?"
Dividing a track	"Combine Undo ?"
Combining tracks	"Move Undo ?"
Moving a track	"Name Undo ?"
Labeling a track or an MD	
Changing an existing title	
Erasing all titles on an MD	

- Press YES again. "Complete" appears for a few seconds and the contents of the MD are restored to the condition that existed before the edit.

To cancel the Undo Function Press EDIT/NO or ■.

Guide to the Serial Copy Management System

This MD deck uses the Serial Copy Management System, which allows only first-generation digital copies to be made of premastered software via the deck's digital input jack. An outline of this system appears below:

- 1 You can record from digital program sources (CDs, DATs or premastered MDs) onto a DAT tape or recordable MD via digital input jack on the DAT or MD deck.

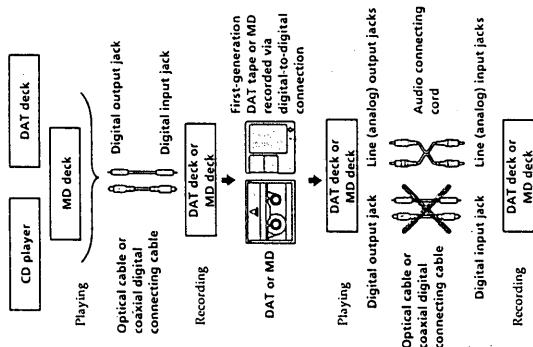

- 2 You can record the digital input signal of a digital satellite broadcast onto a DAT tape or recordable MD via the digital input jack on the DAT or MD deck which is capable of handling a sampling frequency of 32 kHz or 48 kHz. You can then record the contents of this recorded DAT tape or MD (first-generation) onto another DAT tape or recordable MD via digital input jack on the DAT or MD deck to create a second-generation digital copy. Subsequent recording from the second-generation copy onto another recordable DAT tape or MD is possible only through the analog input jack on the DAT or MD deck. Note, however, that on some BS tuners, second-generation digital copying may not be possible.

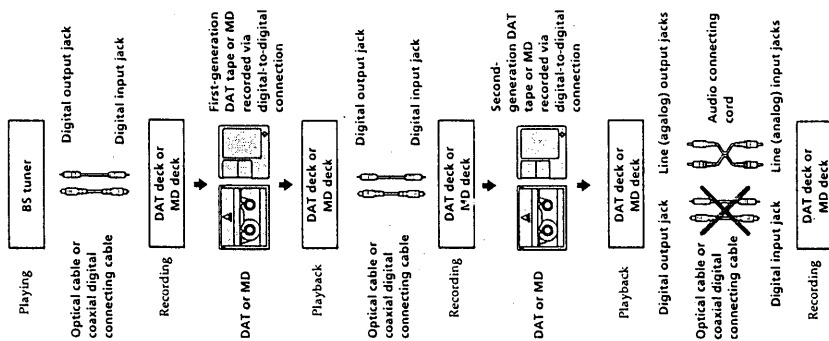

(Continued)

- 3 You can record a DAT tape or MD recorded via the DAT or MD deck's analog input jack onto another DAT tape or MD via the DAT or MD deck's digital output jack. You cannot, however, make a second-generation DAT tape or MD copy via the DAT or MD deck's digital output jack.

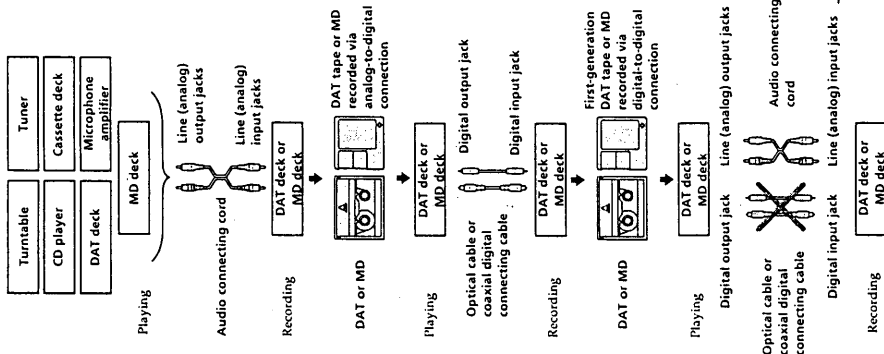

Setting the voltage selector (only on models supplied with a voltage selector)

Check that the voltage selector on the rear panel of the deck is set to the local power line voltage. If not, set the selector to the correct position using a screwdriver before connecting the AC power cord to an AC outlet.

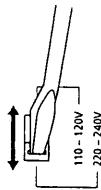

Connecting the AC power cord

Connect the AC power cord to a wall outlet or to the outlet of a timer.

SECTION 2 DISASSEMBLY

Note: Follow the disassembly procedure in the numerical order given.

2-1. CASE AND FRONT PANEL ASSEMBLY

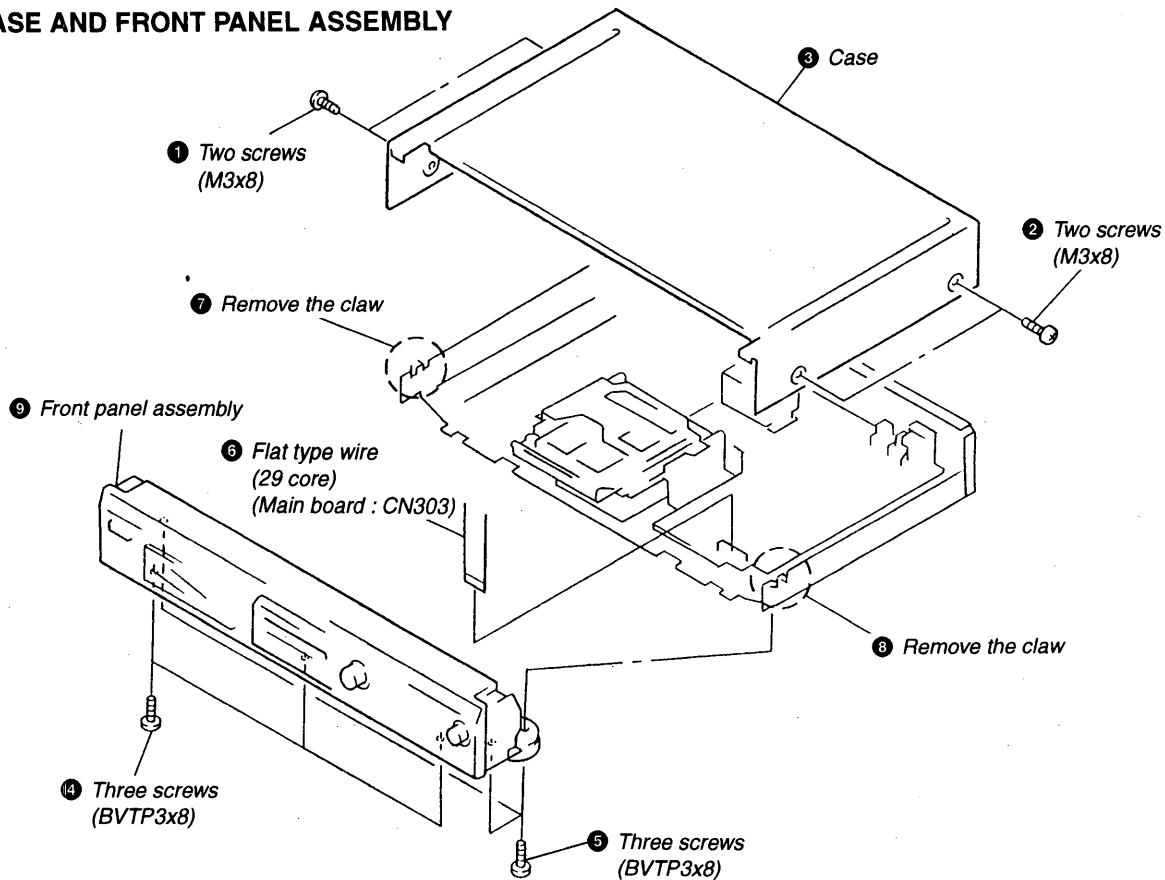

2-2. BRACKET (T), (L) AND (R)

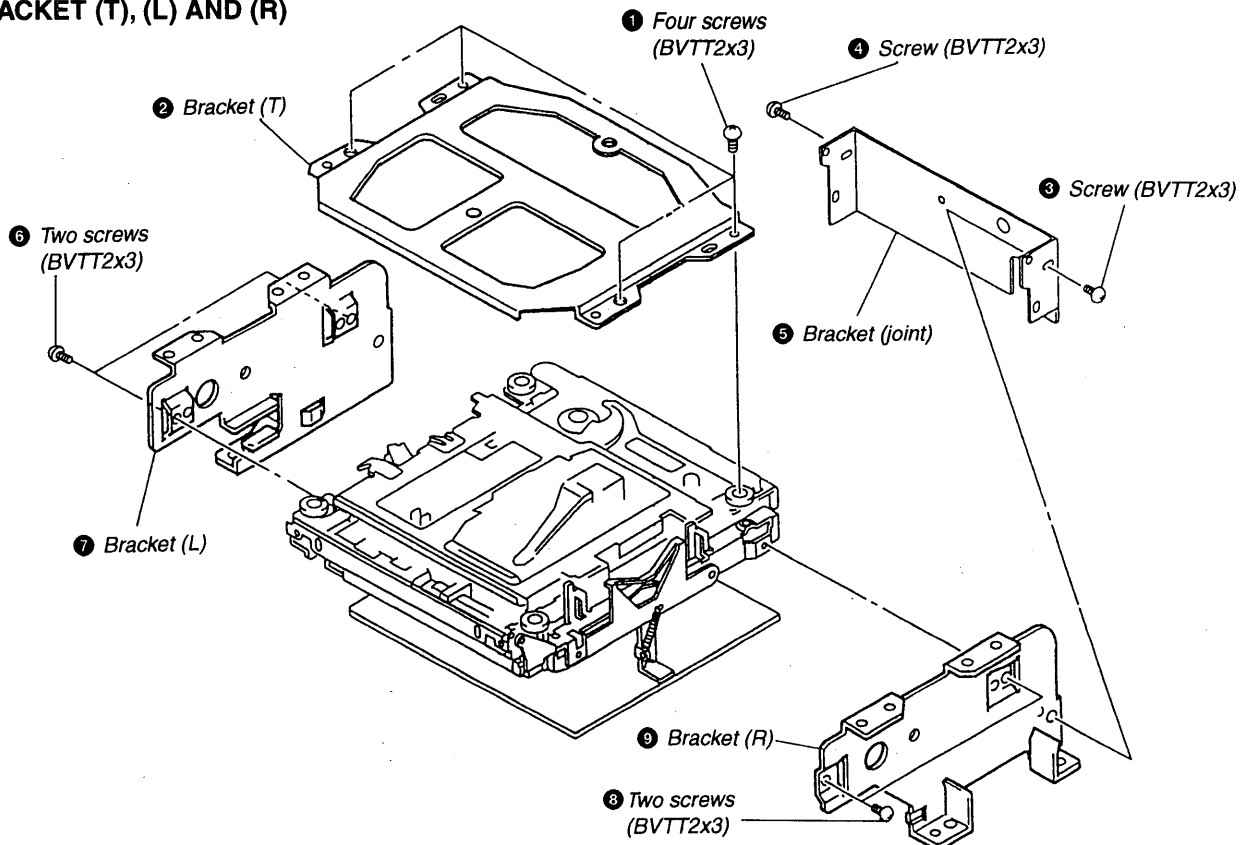

2-3. BD BOARD

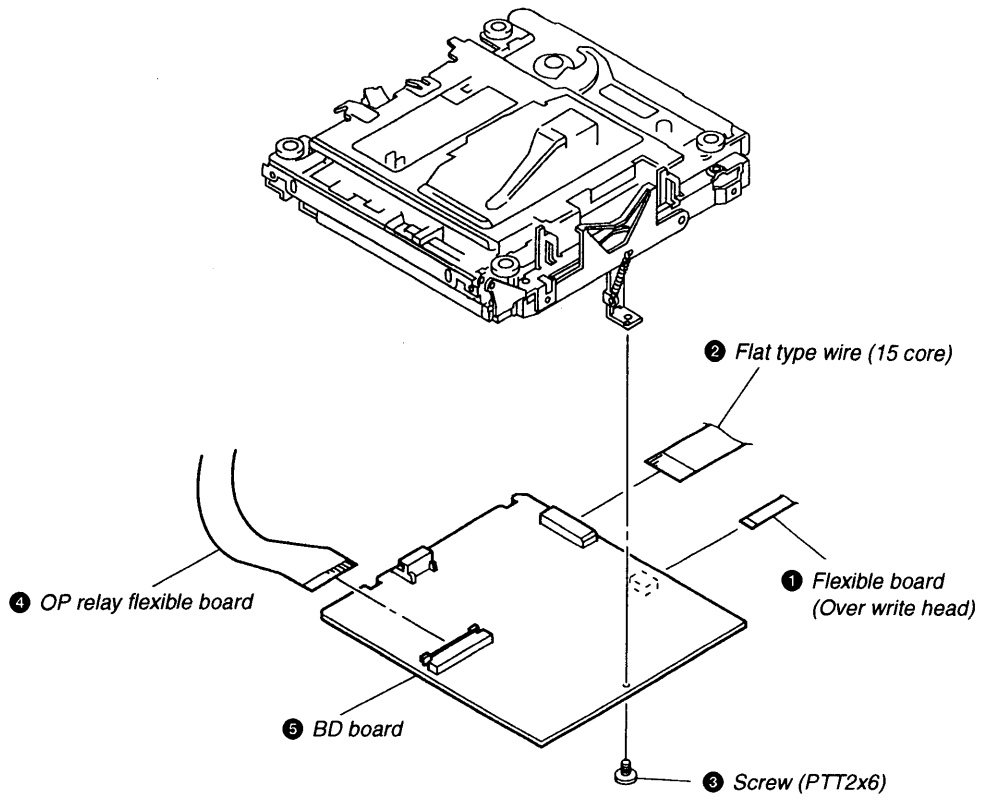

2-4. SUB CHASSIS

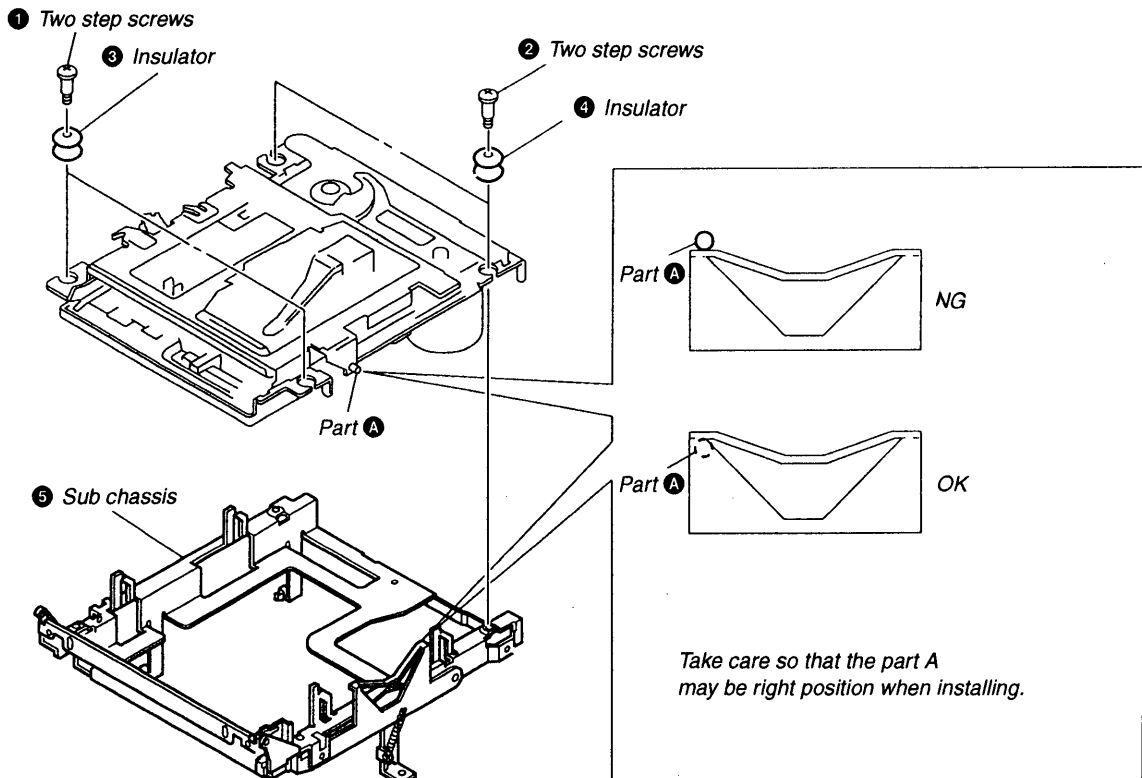

2-5. SHUTTER ASSEMBLY

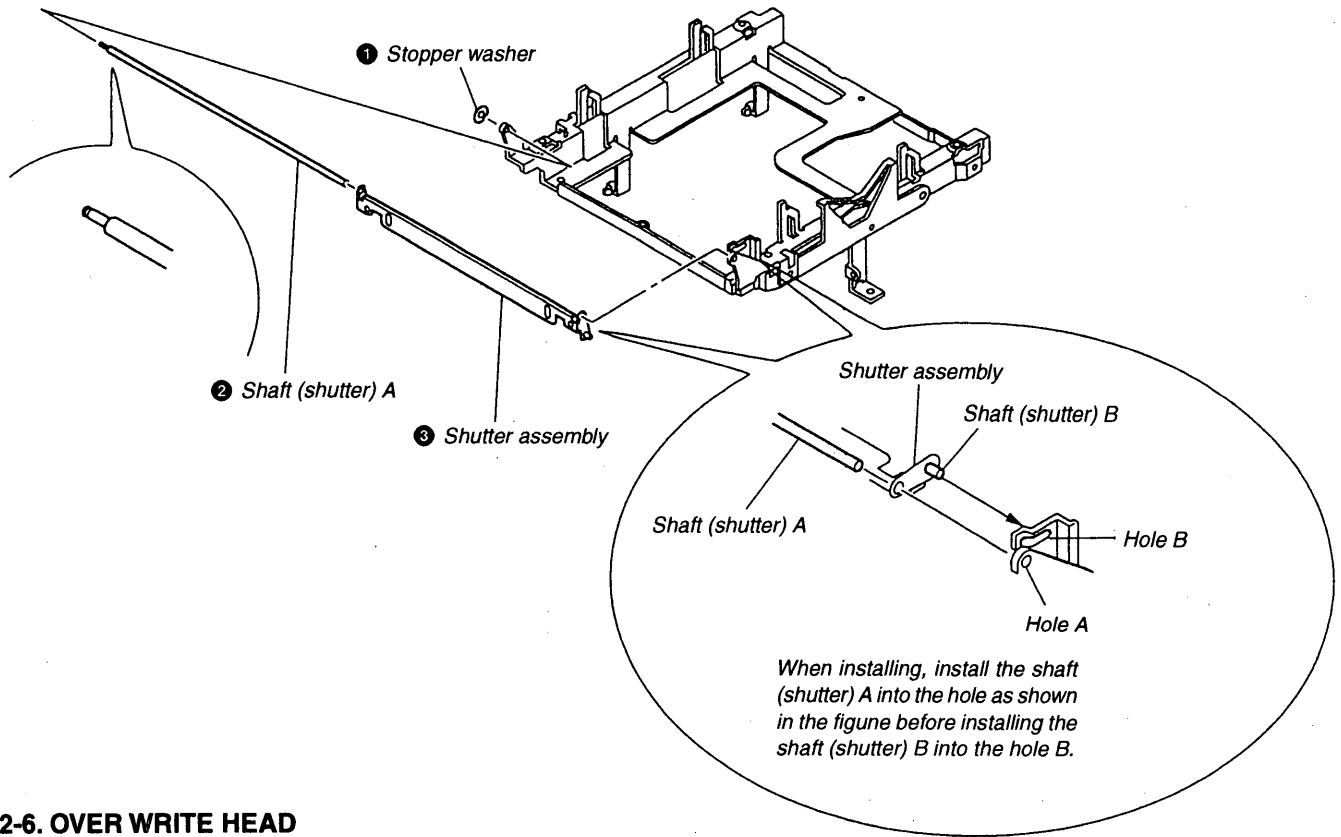

2-6. OVER WRITE HEAD

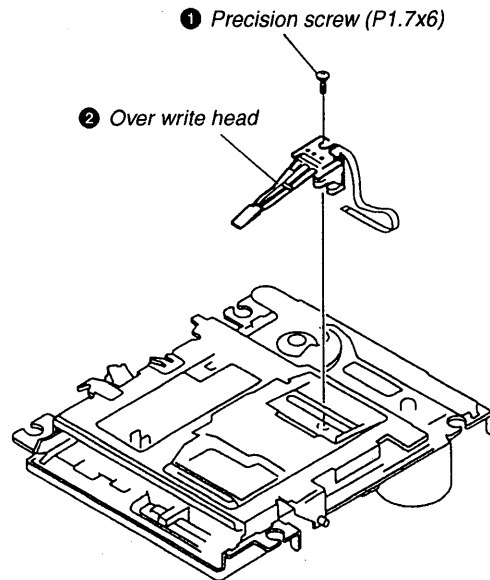

2-7. SLIDER COMPLETE ASSEMBLY

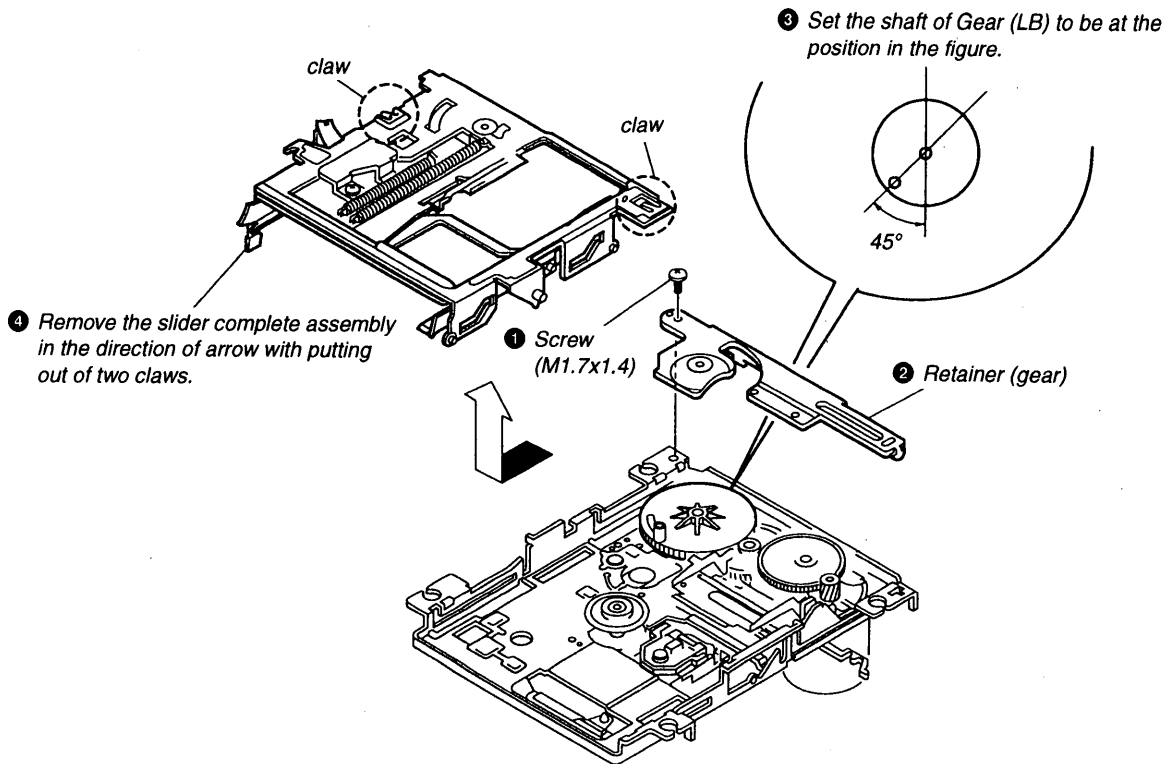

• Note for Installation of Slider Complete Assembly

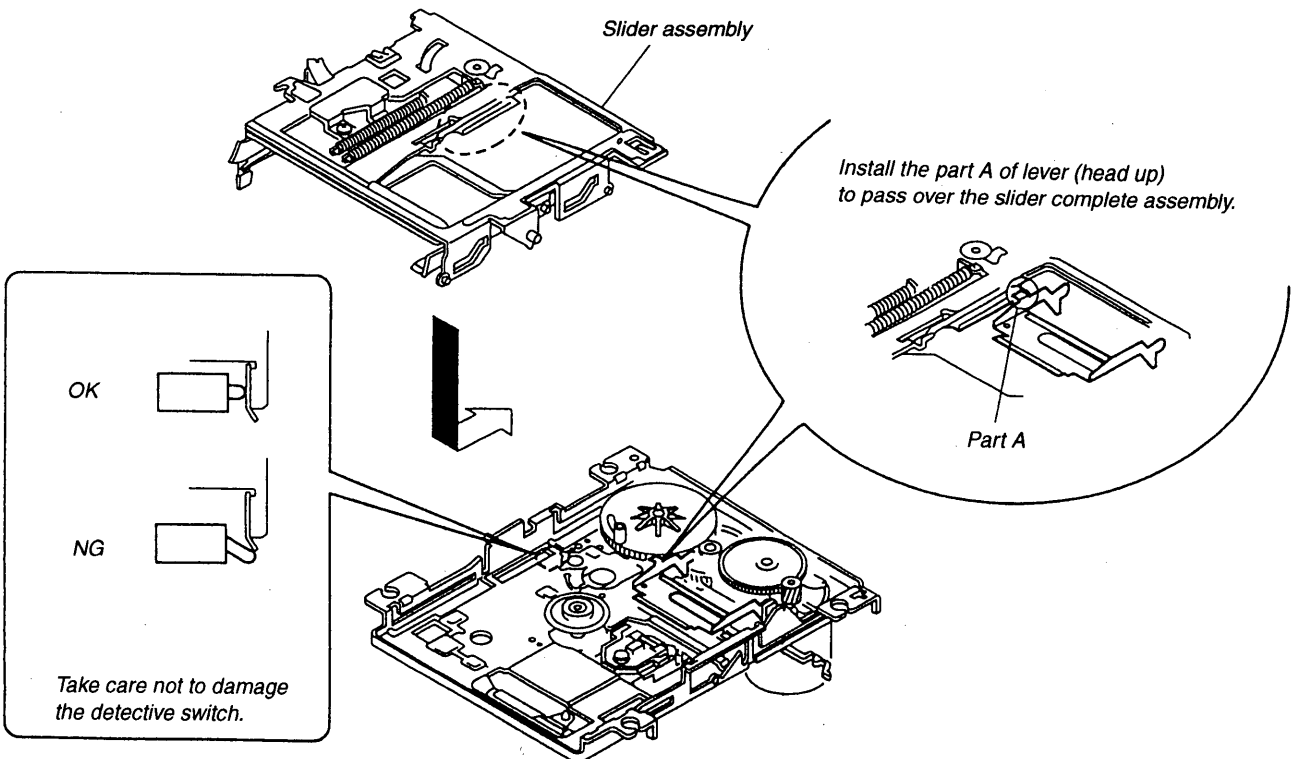

SECTION 3 TEST MODE

3-1. Precautions for Use of Test Mode

- ① As loading related operations will be performed regardless of the test mode operations being performed, be sure to check that the disc is stopped before setting and removing it.
Even if the EJECT button is pressed while the disc is rotating during continuous playback, continuous recording, etc., the disc will not stop rotating.
Therefore, it will be ejected while rotating.
Be sure to press the EJECT button after pressing the NO button and the rotation of disc is stopped.
- ② The erasing-protection tab is not detected in the test mode. Therefore, operating in the recording laser emission mode and pressing the ●REC button, the recorded contents will be erased regardless of the position of the tab. When using a disc that is not to be erased in the test mode, be careful not to enter the continuous recording mode and traverse adjustment mode.

3-1-1. Recording laser emission mode and operating buttons

1. Continuous recording mode (CREC MODE)
2. Traverse adjustment mode (EFBAL ADJUST)
3. Laser power adjustment mode (LDPWR ADJUST)
4. Laser power check mode (LDPWR CHECK)
5. When pressing the ●REC button.

3-2. Setting the Test Mode

While pressing the AMS knob, insert the power plug into the power supply inlet, and release the AMS knob.

3-3. Exiting the Test Mode

When the REPEAT button is pressed, it becomes in the STANDBY mode. Or unplug the power plug from an outlet.

3-4. Basic Operations of the Test Mode

All operations are performed using the AMS knob, YES button, and NO button.
The functions of these buttons are as follows.

Function name	Function
AMS knob	Changes parameters and modes
YES button	Proceeds onto the next step. Finalizes input.
NO button	Returns to previous step. Stops operations.

3-5. Selecting the Test Mode

Thirteen test modes are selected by turning the AMS knob.

Display	Contents
TEMP ADJUST	Temperature compensation offset adjustment
LDPWR ADJUST	Laser power adjustment
LDPWR CHECK	Laser power check
EFBAL ADJUST	Traverse adjustment
FBIAS ADJUST	Focus bias adjustment
FBIAS CHECK	Focus bias check
CPLAY MODE	Continuous playback mode
CREC MODE	Continuous recording mode
DETRK CHECK	Detrack check
S curve CHECK	S curve check *
EEP MODE	Non-volatile memory mode *
MANUAL CMD	Manual command transfer mode *
SVDATA READ	Data reading out mode *

For detailed description of each adjustment mode, refer to "4. Electrical Adjustments".

If a different adjustment mode has been selected by mistake, press the NO button to exit from this mode.

* The EEP MODE, S curve CHECK, MANUAL CMD and SVDATA READ are not used in servicing. If set accidentally, press the NO button immediately to exit this mode.

3-5-1. Operating the Continuous Playback Mode

1. Entering the continuous playback mode

- ① Set the disc in the unit. (Whichever recordable discs or discs for playback only are available.)
- ② Rotate the AMS knob and display "CPLAY MODE".
- ③ Press the YES button to change the display to "CPLAY IN".
- ④ When access completes, the display changes to "C1 = 0000 AD = 00".

Note : The numbers "0" displayed show you error rates and ADER.

2. Changing the parts to be played back

- ① Press the YES button during continuous playback to change the display as below.

"CPLAY MID" → "CPLAY OUT" → "CPLAY IN"

When pressed another time, the parts to be played back can be moved.

- ② When access completes, the display changes to "C1 = 0000 AD = 00".

Note : The numbers "0" displayed show you error rates and ADER.

3. Ending the continuous playback mode

- ① Press the NO button. The display will change to "CPLAY MODE".
- ② Press the EJECT button to remove the disc.

Note : The playback start addresses for IN, MID, and OUT are as follows. In case you want to display the address of the playback position on the display, press the DISPLAY/CHAR button and display "CPLAY (0000)".

IN 40h cluster
MID 300h cluster
OUT 700h cluster

3-5-2. Operating the Continuous Recording Mode

1. Entering the continuous recording mode

- ① Set a recordable disc in the unit.
- ② Rotate the AMS knob and display "CREC MODE".
- ③ Press the YES button to change the display to "CREC MID".
- ④ When access completes, the display changes to "CREC (0000)" and **REC** lights up.

Note : The numbers "0" displayed shows you the recording position addresses.

2. Changing the parts to be recorded

- ① When the YES button is pressed during continuous recording, the display changes as below.

"CPLAY MID" → "CPLAY OUT" → "CPLAY IN"

When pressed another time, the parts to be recorded can be changed. **REC** goes off.

- ② When access completes, the display changes to "CREC (0000)" and **REC** lights up.

Note : The numbers "0" displayed shows you the recording position addresses.

3. Ending the continuous recording mode

- ① Press the NO button. The display changes to "CREC MODE" and **REC** goes off.
- ② Press the EJECT button to remove the disc.

Note 1 : The recording start addresses for IN, MID, and OUT are as follows.

IN 40h cluster
MID 300h cluster
OUT 700h cluster

Note 2 : The NO button can be used to stop recording anytime.

Note 3 : During the test mode, the erasing-protection tab will not be detected. Therefore be careful not to set the continuous recording mode when a disc not to be erased is set in the unit.

Note 4 : Do not perform continuous recording for long periods of time above 5 minutes.

Note 5 : During continuous recording, be careful not to apply vibration.

3-5-3. Non-Volatile Memory Mode

This mode reads and writes the contents of the non-volatile memory.

It is not used in servicing. If set accidentally, press the NO button immediately to exit it.

3-6. Functions of Other buttons

Function	Contents
▷	Sets continuous playback when pressed in the STOP state. When pressed during continuous playback, the tracking servo turns ON/OFF.
■	Stops continuous playback and continuous recording.
▶▶	The sled moves to the outer circumference only when this is pressed.
◀◀	The sled moves to the inner circumference only when this is pressed.
● REC	Turns recording ON/OFF when pressed during continuous playback.
PLAY MODE	Switches between the pit and groove modes when pressed.
PROGRAM	Switches the spindle servo mode (CLVS and A).
DISPLAY	Switches the display when pressed. Returns to previous step. Stops operations.

Note : The erasing-protection tab is not detected during the test mode. Recording will start regardless of the position of the erasing-protection tab when the ● REC button is pressed.

3-7. Test Mode Displays

Each time the DISPLAY/CHAR button is pressed, the display changes in the following order.

MODE display → Error rate display → Address display → Auto gain display → IVR display

The auto gain display and the IVR display are not used for servicing.

1. MODE display

Displays "TEMP ADJUST", "CPLAY MODE", etc.

2. Error rate display

Error rates are displayed as follows.

C1 = 0000 AD = 0000

C1 = : Indicates C1 error

AD = : Indicates ADER

3. Address display

Addresses are displayed as follows.

h = 0000 s = 0000 (MO pit and CD) (MO : Recordable disc, CD : Disc for playback only)

h = 0000 a = 0000 (MO groove)

h = : Header address

s = : SUBQ address

a = : ADIP address

* "_" is displayed when the address cannot be read.

4. Auto gain display

Auto gains are displayed as follows.

AG F = 00 T = 00

F = Focus auto gain collection value.

T = Tracking auto gain collection value.

3-8. Meanings of Other Displays

Display	Contents		
	Light	Off	Blinking
▷	During continuous playback	STOP	
	Tracking servo OFF	Tracking servo ON	
REC	Recording mode ON	Recording mode OFF	
CLOCK	CLV LOCK	CLV UNLOCK	
TRACK	Pit	Groove	
DISC	High reflection	Low reflection	
DATE	CLV-S	CLV-A	
A. SPACE	ABCD adjustment completed		
A - B	(Focus auto gain successful Tracking auto gain successful)		(Focus auto gain successful Tracking auto gain failed)

SECTION 4 ELECTRICAL ADJUSTMENTS

4-1. Precautions for Checking Laser Diode Emission

To check the emission of the laser diode during adjustments, never view directly from the top as this may lose your eye-sight.

4-2. Precautions for Use of optical pick-up (KMS-260A)

As the laser diode in the optical pick-up is easily damaged by static electricity, solder the laser tap of the flexible board when using it. Before disconnecting the connector, desolder first. Before connecting the connector, be careful not to remove the solder. Also take adequate measures to prevent damage by static electricity. Handle the flexible board with care as it breaks easily.

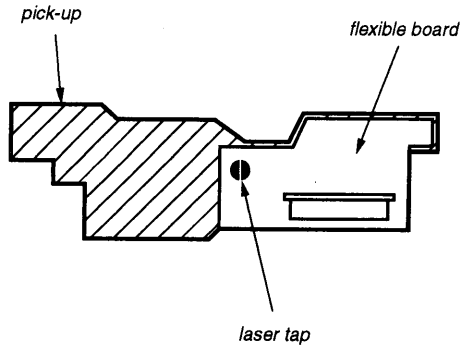

Optical pick-up flexible board

4-3. Precautions for Adjustments

1) When replacing the following parts, perform the adjustments and checks with ○ in the order shown in the following table.

	Optical Pick-up	BD Board		
		IC171	D101	IC101, IC121, IC192
1. Temperature compensation offset adjustment	×	○	○	○
2. Laser power adjustment	○	○	×	○
3. Traverse adjustment	○	○	×	○
4. Focus bias adjustment	○	○	×	○
5. Error rate check	○	○	×	○

- 2) Set the test mode when performing adjustments.
After completing the adjustments, exit the test mode.
- 3) Perform the adjustments in the order shown.
- 4) Use the following tools and measuring devices.
 - Test disc (Disc for playback only) TDYS-1 (Parts No. 4-963-646-01)
 - Laser power meter LPM-8001 (Parts No. J-2501-046-A)
 - Oscilloscope (Measure after performing CAL of prove.)
 - Digital voltmeter
 - Thermometer
- 5) When observing several signals on the oscilloscope, etc., make sure that VC and ground do not connect inside the oscilloscope.
(VC and ground will become short-circuited.)

4-4. Creating Continuously Recorded Disc

* This disc is used in focus bias adjustment and error rate check.
The following describes how to create a continuous recording disc.

1. Insert a disc (blank disc) commercially available.
2. Rotate the AMS knob and display "CREC MODE".
3. Press the YES button again to display "CREC MID".
Display "CREC (0300)" and start to recording.
4. Complete recording within 5 minutes.
5. Press the NO button and stop recording.
6. Press the EJECT button and remove the disc.

The above has been how to create a continuous recorded data for the focus bias adjustment and error rate check.

Note :

- Be careful not to apply vibration during continuous recording.

4-5. Temperature Compensation Offset Adjustment

Save the temperature data at that time in the non-volatile memory as 25 °C reference data.

Note :

1. Usually, do not perform this adjustment.
2. Perform this adjustment in an ambient temperature of 22 °C to 28 °C. Perform it immediately after the power is turned on when the internal temperature of the unit is the same as the ambient temperature of 22 °C to 28 °C.
3. When D101 has been replaced, perform this adjustment after the temperature of this part has become the ambient temperature.

Adjusting Method :

1. Rotate the AMS knob and display "TEMP ADJUST".
2. Press the YES button and select the "TEMP ADJUST" mode.
3. "TEMP = $\square\square\square$ " and the current temperature data will be displayed.
4. To save the data, press the YES button.
When not saving the data, press the NO button.
5. When the YES button is pressed, "TEMP = $\square\square\square$ SAVE" will be displayed and turned back to "TEMP ADJUST" display then.
When the NO button is pressed, "TEMP ADJUST" will be displayed immediately.

Specified Value :

The "TEMP = $\square\square\square$ " should be within "E0 - EF", "F0 - FF", "00 - 0F", "10 - 1F" and "20 - 2F".

4-6. Laser Power Adjustment

Connection :

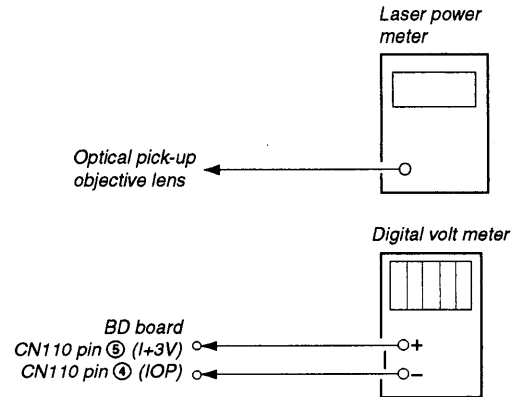

Adjusting Method :

1. Set the laser power meter on the objective lens of the optical pickup.
(When it cannot be set properly, press the ◀◀ button or ▶▶ button to move the optical pick-up.)
Connect the digital volt meter to CN110 pin ⑤ (I+3V) and CN110 pin ④ (IOP).
 2. Rotate the AMS knob and display "LDPWR ADJUST".
(Laser power : For adjustment)
 3. Press the YES button once and display "LD 0.9 mW \$ $\square\square\square$ ".
 4. Rotate the AMS knob so that the reading of the laser power meter becomes 0.86 to 0.92 mW. Press the YES button after setting the range knob of the laser power meter, and save the adjustment results. ("LD SAVE \$ $\square\square\square$ " will be displayed for a moment.)
 5. Then "LD 7.0 mW \$ $\square\square\square$ " will be displayed".
 6. Rotate the AMS knob so that the reading of the laser power meter becomes 6.9 to 7.1 mW, press the YES button and save it.
- Note :** Do not perform the emission with 7.0 mW more than 15 seconds continuously.
7. Then, rotate the AMS knob and display "LDPWR CHECK".
 8. Press the YES button once and display "LD 0.9 mW \$ $\square\square\square$ ". Check that the reading of the laser power meter become 0.85 to 0.91 mW.
 9. Press the YES button once more and display "LD 7.0 mW \$ $\square\square\square$ ". Check that the reading the laser power meter and digital volt meter satisfy the specified value.

Specified Value :

Laser power meter reading : 7.0 ± 0.1 mW
Digital voltmeter reading : Optical pick-up displayed value $\pm 10\%$

(Optical pick-up label)

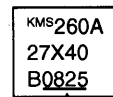

$lop = 82.5$ mA in this case
 lop (mA) = Digital voltmeter reading (mV)/1 (Ω)

10. Press the NO button and display "LDPWR CHECK" and stop the laser emission.
(The NO button is effective at all times to stop the laser emission.)

4-7. Traverse Adjustment

Connection :

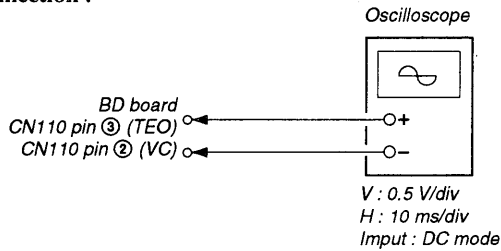

Adjusting method :

1. Connect an oscilloscope to CN110 pin ③ (TEO) and CN110 pin ② (VC) of the BD board.
2. Load a disc (any available on the market). (Refer to Note 1.)
3. Press the ◀ button or ▶ button and move the optical pickup outside the pit.
4. Rotate the AMS knob and display "EFBAL ADJUST".
5. Press the YES button and display "EFB = $\square\square$ MO-R". (Laser power READ power/Focus servo ON/tracking servo OFF/spindle (S) servo ON)
6. Rotate the AMS knob so that the waveform of the oscilloscope becomes the specified value. (When the AMS knob is rotated, the $\square\square$ of "EFB = $\square\square$ " changes and the waveform changes.) In this adjustment, waveform varies at intervals of approx. 2%. Adjust the waveform so that the specified value is satisfied as much as possible. (Read power traverse adjustment)

(Traverse Waveform)

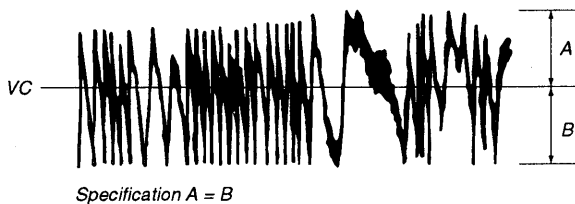

7. Press the YES button and save the result of adjustment to the non-volatile memory ("EFB = $\square\square$ SAVE" will be displayed for a moment. Then "EFB = $\square\square$ MO-W" will be displayed).
8. Rotate the AMS knob so that the waveform of the oscilloscope becomes the specified value. (When the AMS knob is rotated, the $\square\square$ of "EFB = $\square\square$ " changes and the waveform changes.) In this adjustment, waveform varies at intervals of approx. 2%. Adjust the waveform so that the specified value is satisfied as much as possible. (Write power traverse adjustment)

(Traverse Waveform)

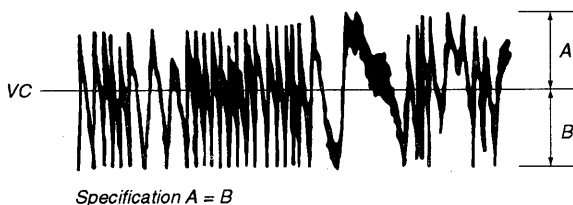

9. Press the YES button, and save the adjustment results in the non-volatile memory. ("EFB = $\square\square$ SAVE" will be displayed for a moment.)
10. "EFB = $\square\square$ MO-P" will be displayed. The optical pick-up moves to the pit area automatically and servo is imposed.

11. Rotate the AMS knob until the waveform of the oscilloscope moves closer to the specified value. In this adjustment, waveform varies at intervals of approx. 2%. Adjust the waveform so that the specified value is satisfied as much as possible.

(Traverse Waveform)

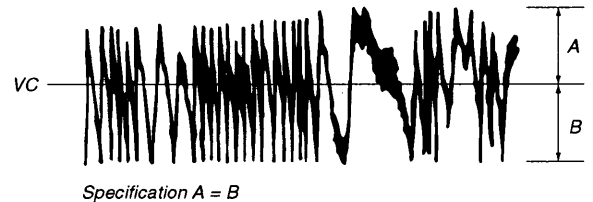

12. Press the YES button, and save the adjustment results in the non-volatile memory. ("EFB = $\square\square$ SAVE" will be displayed for a moment.) Next "EFBAL CD" is displayed. The disc stops rotating automatically.
13. Press the EJECT button and remove the disc.
14. Load the test disc TDYS-1.
15. Press the YES button and display "EFB = $\square\square$ CD". Servo is imposed automatically.
16. Rotate the AMS knob so that the waveform of the oscilloscope moves closer to the specified value. In this adjustment, waveform varies at intervals of approx. 2%. Adjust the waveform so that the specified value is satisfied as much as possible.

(Traverse Waveform)

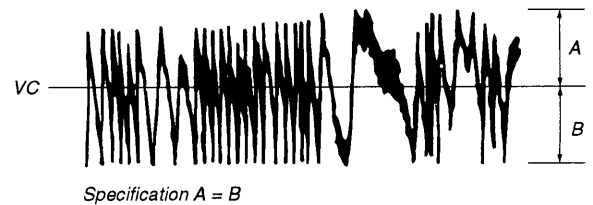

17. Press the YES button, display "EFB = $\square\square$ SAVE" for a moment and save the adjustment results in the non-volatile memory. Next "EFBAL ADJUST" will be displayed.
18. Press the EJECT button and remove the test disc TDYS-1.

Note 1 : MO reading data will be erased during if a recorded disc is used in this adjustment.

Note 2 : If the traverse waveform is not clear, connect the oscilloscope as shown in the following figure so that it can be seen more clearly.

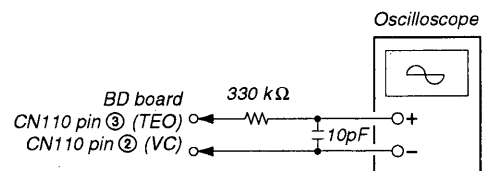

9. Press the YES button, and save the adjustment results in the non-volatile memory. ("EFB = $\square\square$ SAVE" will be displayed for a moment.)
10. "EFB = $\square\square$ MO-P" will be displayed. The optical pick-up moves to the pit area automatically and servo is imposed.

4-8. Focus Bias Adjustment

Adjusting Method :

1. Load a continuously recorded disc (Refer to "4-4. Creating Continuously Recorded Disc").
2. Rotate the AMS knob and display "CPLAY MODE".
3. Press the YES button and display "CPLAY MID".
4. Press the NO button when "C1 = 0000 AD = 00" is displayed.
5. Rotate the AMS knob and display "FBIAS ADJUST".
6. Press the YES button and display "0000/00 a = 00".
The first four digits indicate the C1 error rate, the two digits after [/] indicate ADER, and the 2 digits after [a =] indicate the focus bias value.
7. Rotate the AMS knob in the clockwise direction and find the focus bias value at which the C1 error rate becomes 220 (Refer to Note 2).
8. Press the YES button and display "0000/00 b = 00".
9. Rotate the AMS knob in the counterclockwise direction and find the focus bias value at which the C1 error rate becomes 220.
10. Press the YES button and display "0000/00 c = 00".
11. Check that the C1 error rate is below 50 and ADER is 00. Then press the YES button.
12. If the "(00)" in "00 - 00 - 00 (00)" is above 20, press the YES button.
If below 20, press the NO button and repeat the adjustment from step 2).
13. Press the EJECT button to remove the continuously recorded disc.

Note 1 : The relation between the C1 error and focus bias is as shown in the following figure. Find points a and b in the following figure using the above adjustment. The focal point position C is automatically calculated from points a and b.

Note 2 : As the C1 error rate changes, perform the adjustment using the average value.

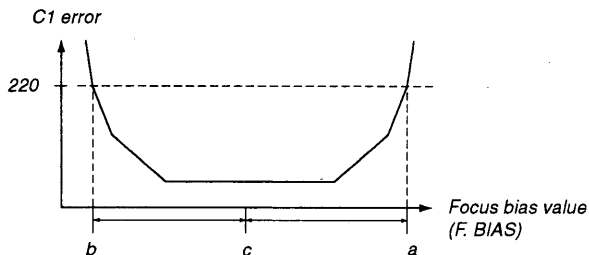

4-9. Error Rate Check

4-9-1. CD Error Rate Check

Checking Method :

1. Load a test disc TDYS-1.
2. Rotate the AMS knob and display "CPLAY MODE".
3. Press the YES button twice and display "CPLAY MID".
4. The display changes to "C1 = 0000 AD = 00".
5. Check that the C1 error rate is below 20.
6. Press the NO button, stop playback, press the EJECT button, and remove the test disc.

4-9-2. MO Error Rate Check

Checking Method :

1. Load a continuously recorded disc (Refer to "4-4. Creating MO Continuously Recorded Disc").
2. Rotate the AMS knob and display "CPLAY MODE".
3. Press the YES button and display "CPLAY MID".
4. The display changes to "C1 = 0000 AD = 00".
5. If the C1 error rate is below 50, check that ADER is 00.
6. Press the NO button, stop playback, press the EJECT button, and remove the continuously recorded disc.

4-10. Focus Bias Check

Change the focus bias and check the focus tolerance amount.

Checking Method :

1. Load a continuously recorded disc (Refer to "4-4. Creating Continuously Recorded Disc").
2. Rotate the AMS knob and display "CPLAY MODE".
3. Press the YES button twice and display "CPLAY MID".
4. Press the NO button when "C1 = 0000 AD = 00" is displayed.
5. Rotate the AMS knob and display "FBIAS CHECK".
6. Press the YES button and display "0000/00 c = 00".
The first four digits indicate the C1 error rate, the two digits after [/] indicate ADER, and the 2 digits after [c =] indicate the focus bias value.
Check that the C1 error is below 50 and ADER is 00.
7. Press the YES button and display "0000/00 b = 00".
Check that the C1 error is not below 220 and ADER is not above 00 every time.
8. Press the YES button and display "0000/00 a = 00".
Check that the C1 error is not below 220 and ADER is not above 00 every time.
9. Press the NO button, next press the EJECT button, and remove the continuously recorded disc.

Note 1 : If the C1 error and ADER are above 00 at points a (step 8. in the above) or b (step 7. in the above), the focus bias adjustment may not have been carried out properly. Adjust perform the beginning again.

4-11. Adjusting Points and Connecting Points

[BD BOARD] (SIDE A)

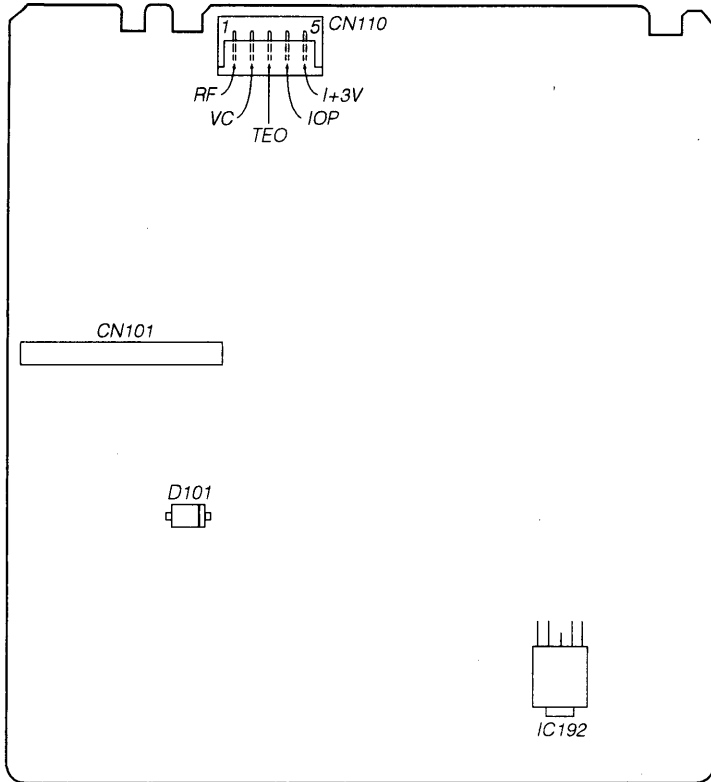

[BD BOARD] (SIDE B)

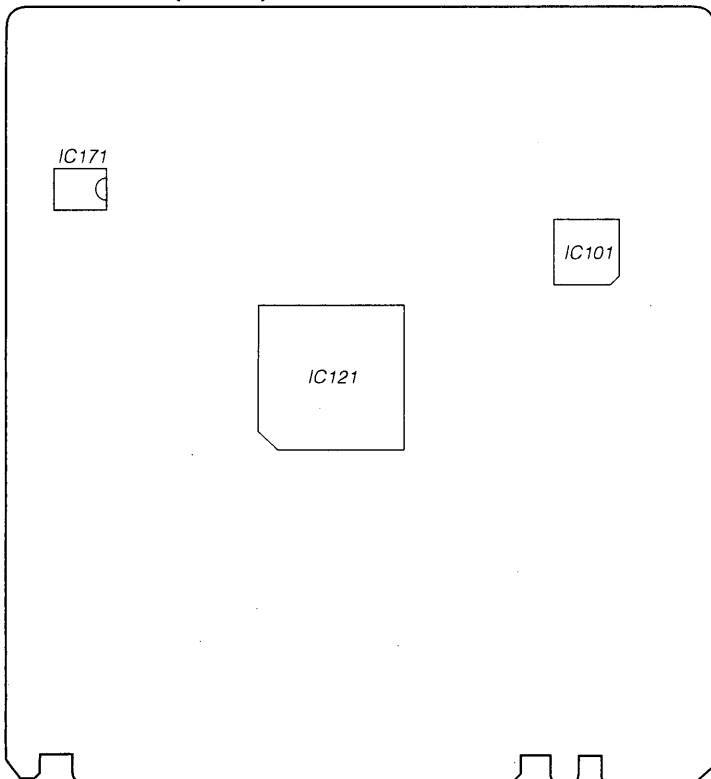

SECTION 5 DIAGRAMS

5-1. CIRCUIT BOARDS LOCATION

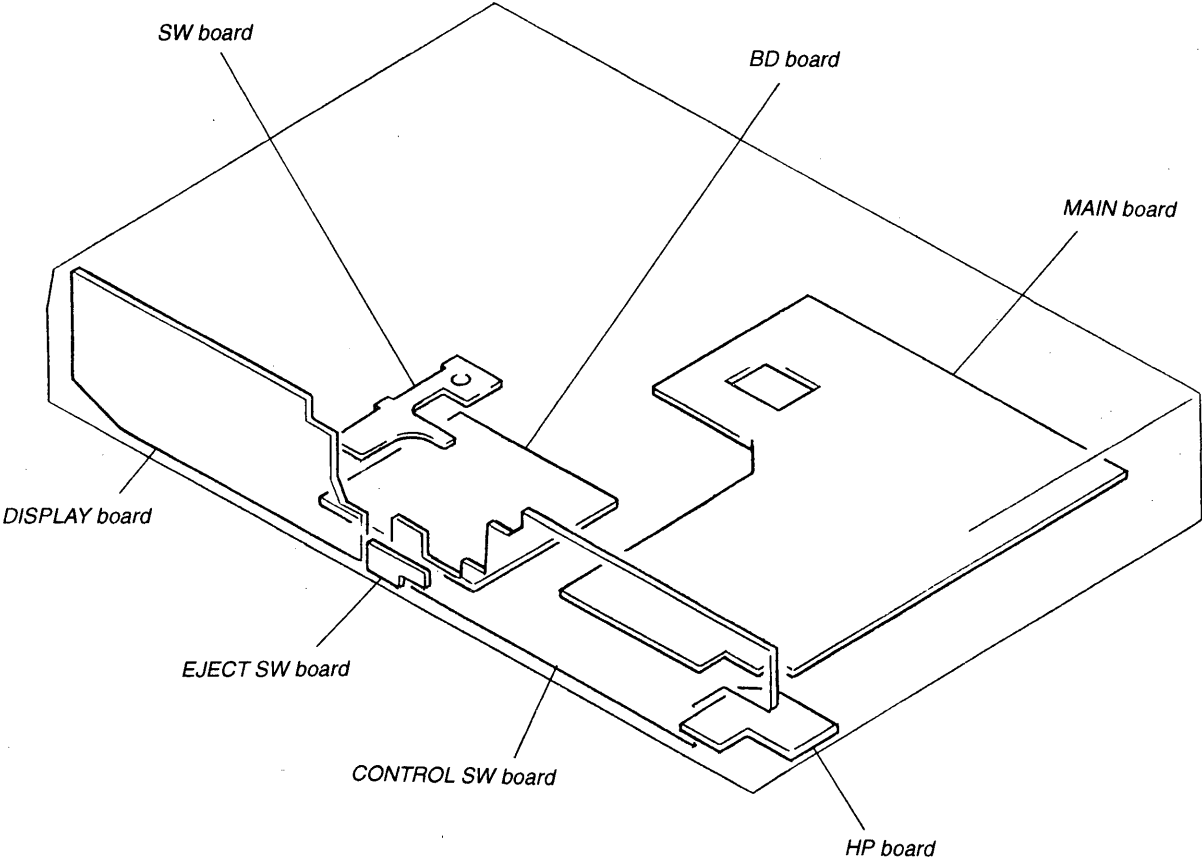

• Semiconductor Location

Ref. No.	Location
D101	E-4
D181	C-9
D183	C-10
IC101	E-13
IC103	B-14
IC121	D-11
IC122	C-6
IC123	D-11
IC152	B-11
IC171	E-9
IC181	C-10
IC192	F-7
Q101	C-13
Q102	B-14
Q103	B-14
Q104	B-14
Q162	B-13
Q163	B-14
Q180	C-8
Q181	B-9
Q182	B-10

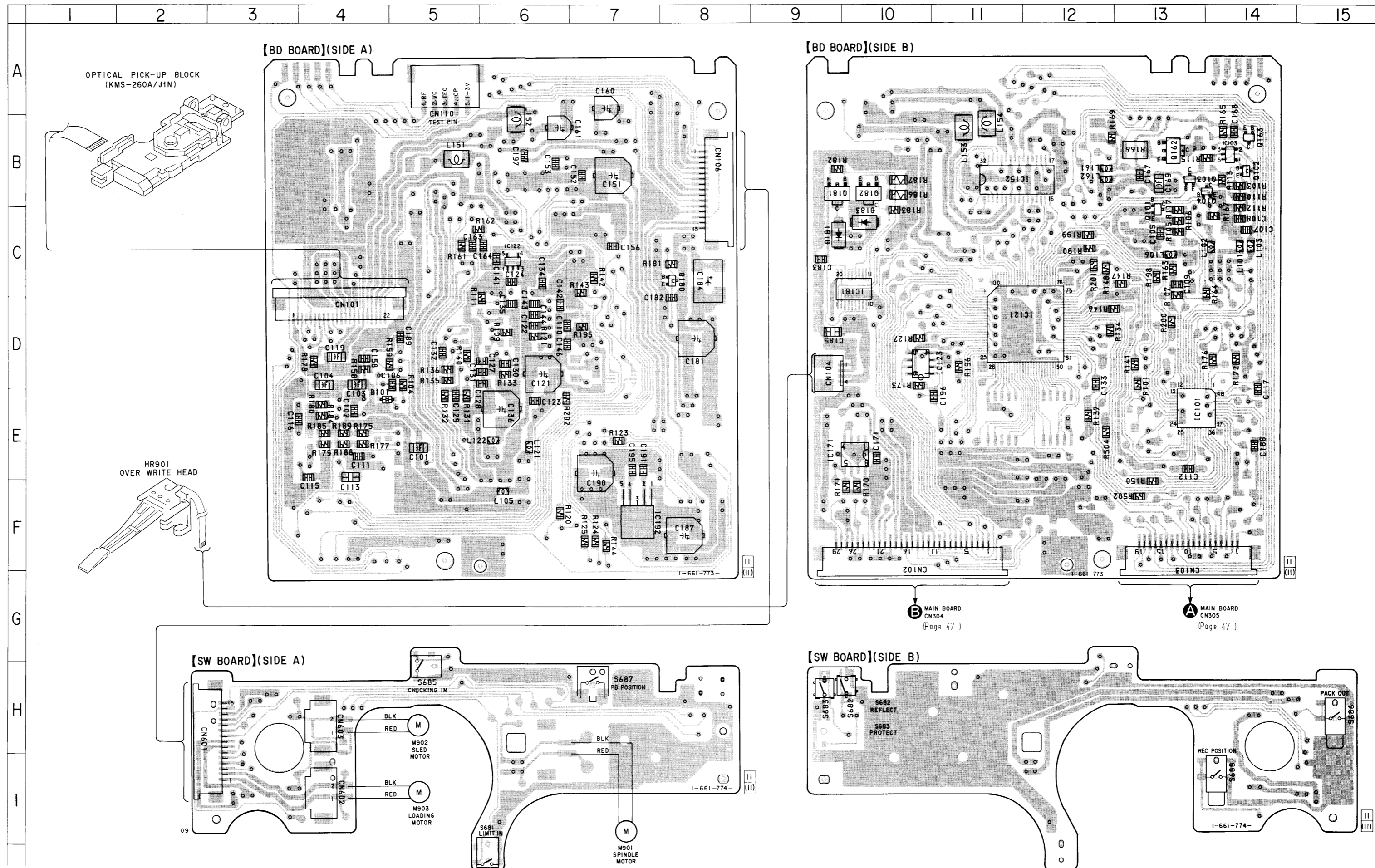

Note:

- : parts extracted from the conductor side.
- : Through hole.
- ▨ : Pattern from the side which enable seeing. (The other layers' patterns are not indicated.)

5-4. SCHEMATIC DIAGRAM — BD SECTION —
 • See page 54 for IC Block Diagrams.
 • See page 57 for IC Pin Functions. (IC101, 121)

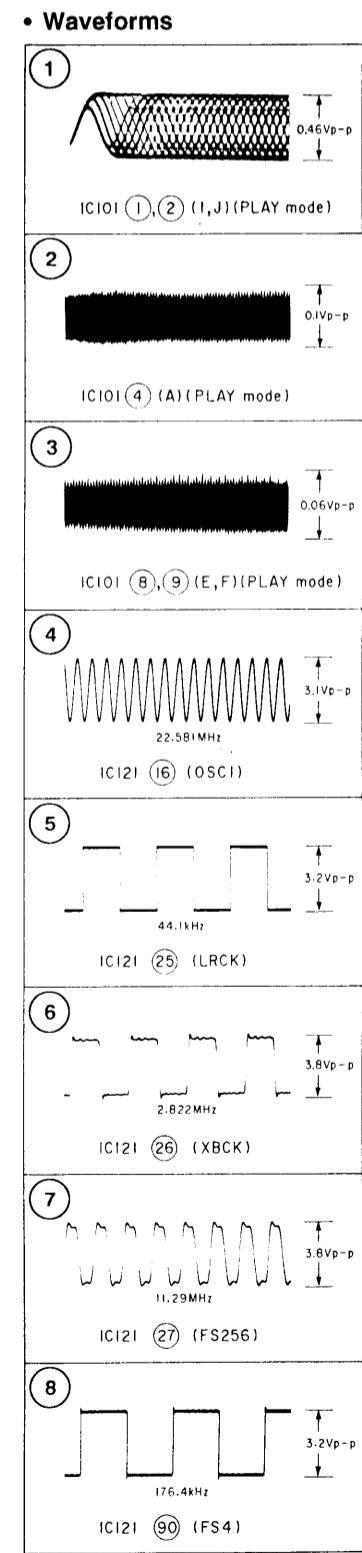
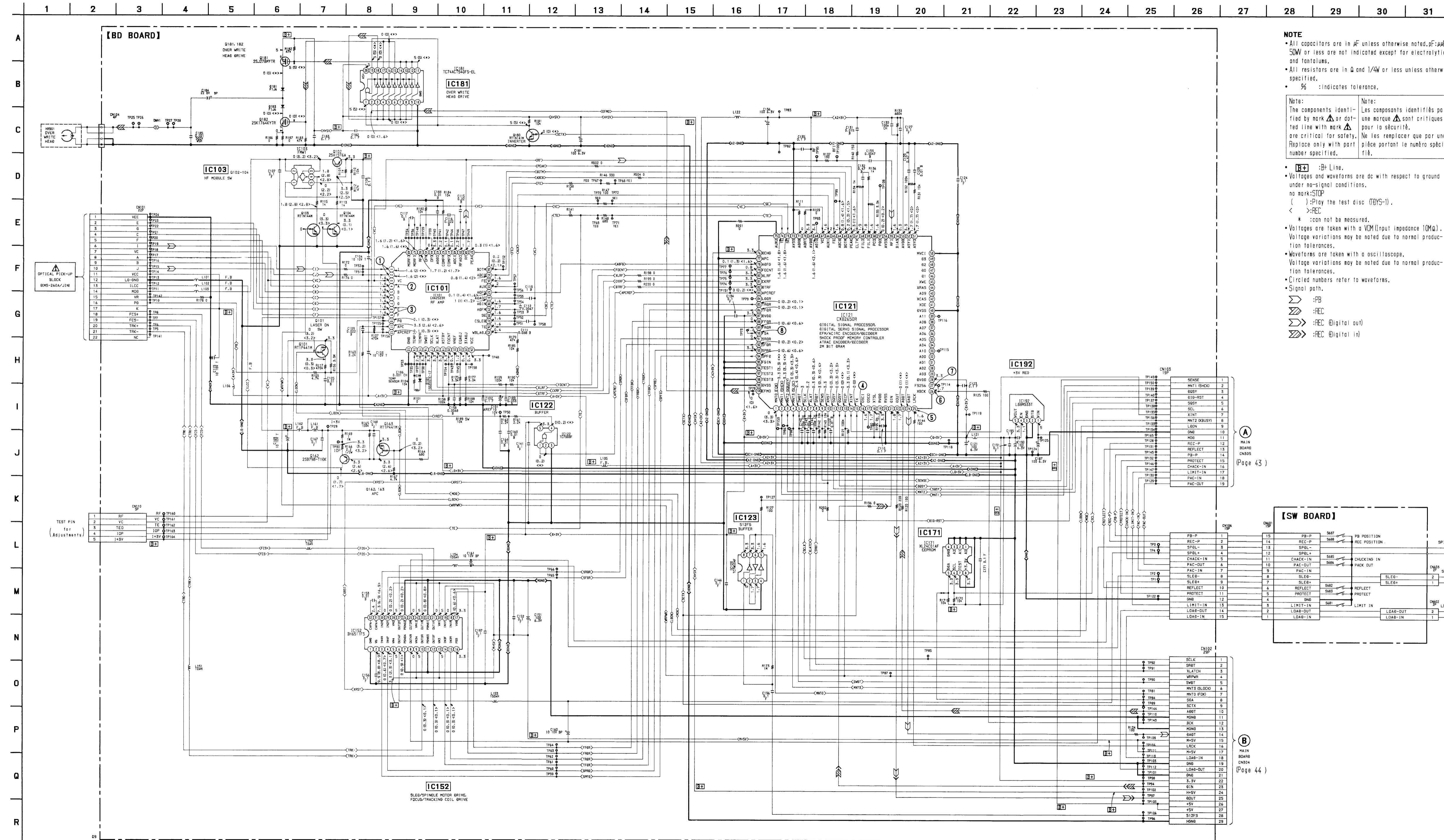

NOTE

- All capacitors are in μF unless otherwise noted. $\text{pF} = \mu\text{F} \times 10^{-6}$
- 50W or less are not indicated except for electrolytics and tantalums.
- All resistors are in Ω and $1/4\text{W}$ or less unless otherwise specified.
- % : indicates tolerance.

Note:
 The components identified by mark Δ or dotted line with mark Δ are critical for safety. Replace only with part number specified.

Note:
 Les composants identifiés par une marque Δ sont critiques pour la sécurité. Ne les remplacer que par une pièce portant le numéro spécifié.

Note:
 +B: B+ Line.
 Voltages and waveforms are dc with respect to ground under no-signal conditions.
 no mark: STOP
 (): Play the test disc (TBYS-1).
 < >: REC
 * : can not be measured.
 Voltages are taken with a VOM (input impedance 10M Ω). Voltage variations may be noted due to normal production tolerances.
 Waveforms are taken with an oscilloscope. Voltage variations may be noted due to normal production tolerances.
 Circled numbers refer to waveforms.
 Signal path.
 \Rightarrow : PB
 \Rightarrow : REC
 \Rightarrow : REC (Digital out)
 \Rightarrow : REC (Digital in)

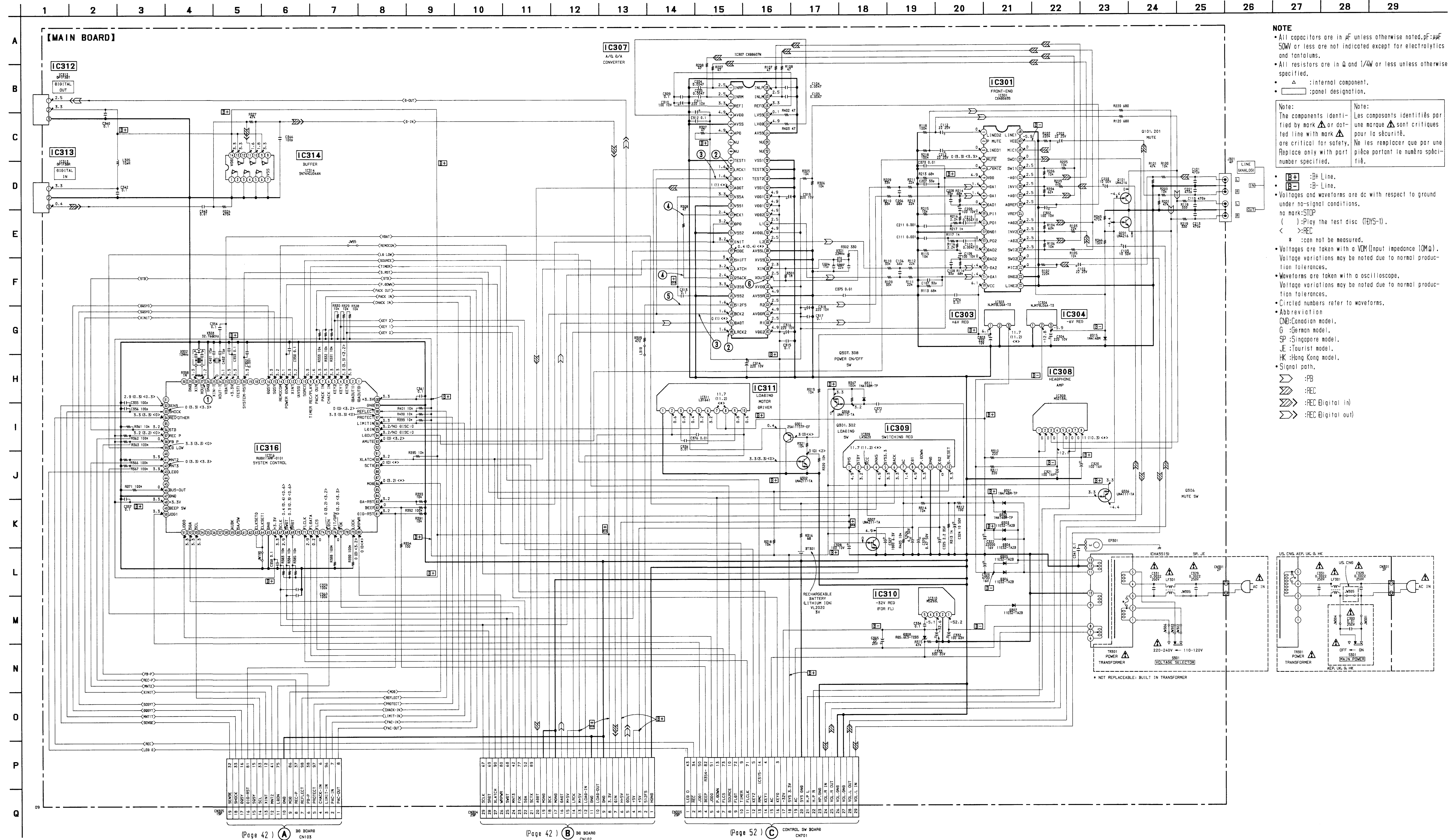

NOTE

- All capacitors are in μF unless otherwise noted. $\text{pF} = \mu\text{F} \times 10^{-6}$.
- 50W or less are not indicated except for electrolytics and tantalums.
- All resistors are in Ω and $1/4\text{W}$ or less unless otherwise specified.
- Δ : internal component.
- \square : panel designation.

Note: The components identified by mark Δ or dotted line with mark Δ are critical for safety. Replace only with part number specified.

Note: Les composants identifiés par une marque Δ sont critiques pour la sécurité. Ne les remplacer que par une pièce portant le numéro spécifié.

- \square :B+ Line.
- \square :B- Line.
- Voltages and waveforms are dc with respect to ground under no-signal conditions.
- no mark: STOP
- () : Play the test disc (TBS-1).
- < > : REC
- * : can not be measured.
- Voltages are taken with a VOM (input impedance $10\text{M}\Omega$). Voltage variations may be noted due to normal production tolerances.
- Waveforms are taken with an oscilloscope. Voltage variations may be noted due to normal production tolerances.
- Circled numbers refer to waveforms.
- Abbreviation: CND: Canadian model, G: German model, SP: Singapore model, JE: Tourist model, HK: Hong Kong model.
- Signal path:
- \Rightarrow : PB
- \Rightarrow : REC
- \Rightarrow : REC (digital in)
- \Rightarrow : REC (digital out)

• Waveforms

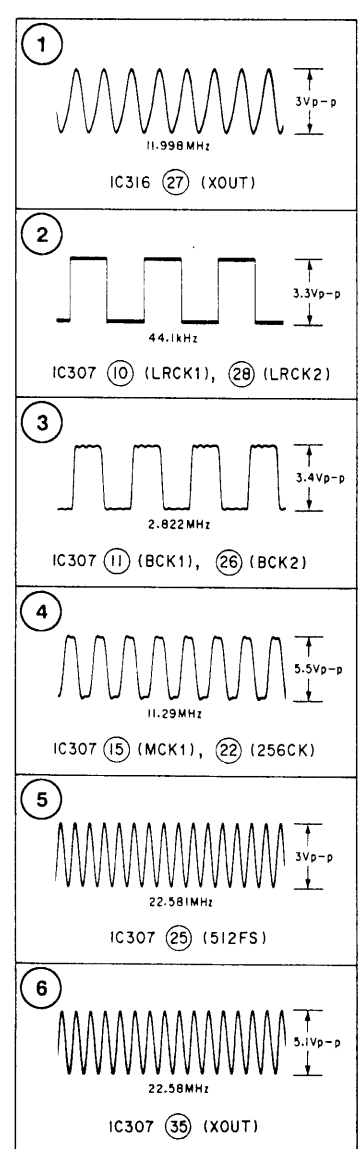

• See page 30 for Circuit Boards Location.

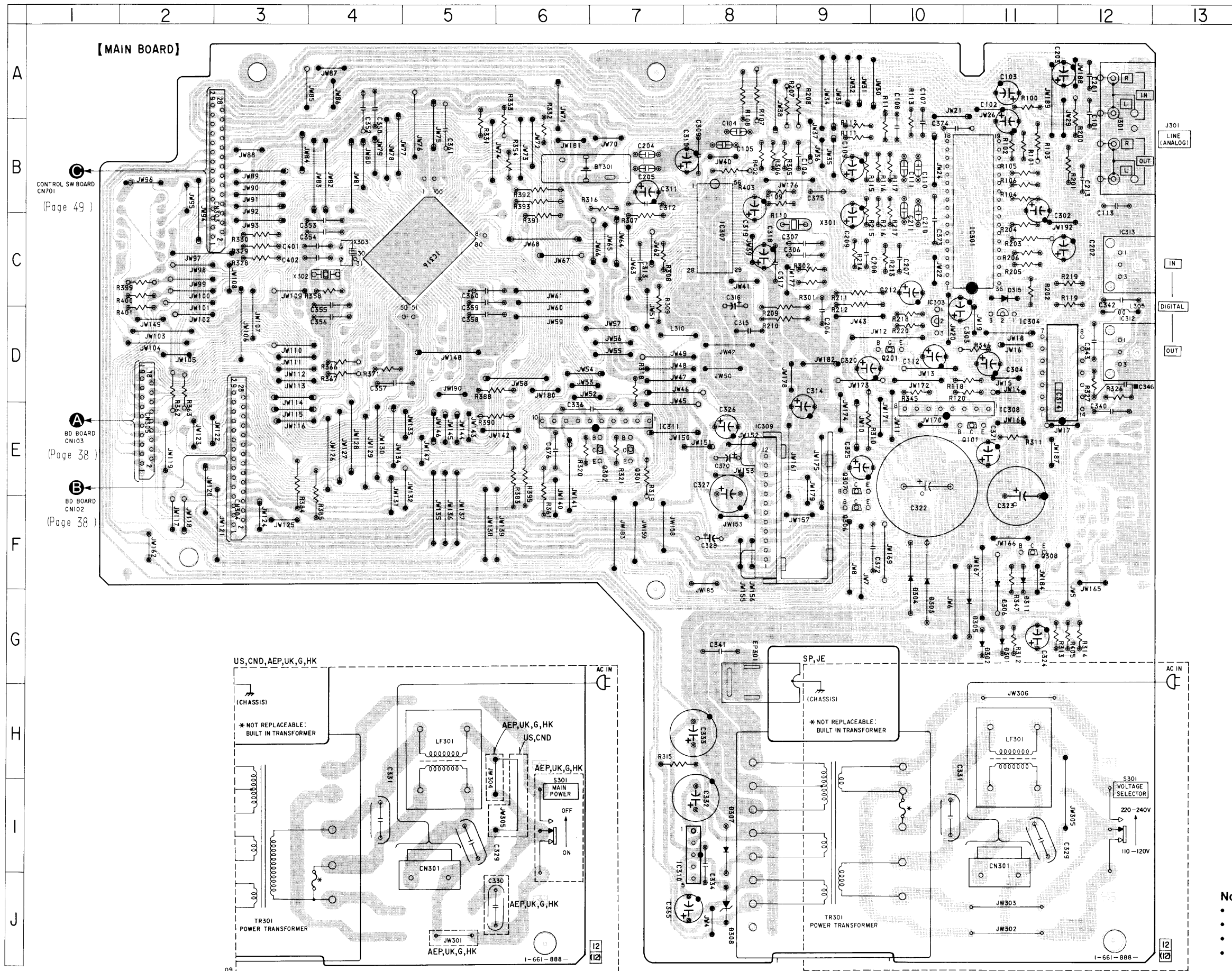

• Semiconductor Location

Ref. No.	Location
D301	G-11
D302	G-11
D303	G-10
D304	G-10
D305	G-11
D306	G-11
D307	I-8
D308	J-8
D311	G-11
D315	C-11
IC301	C-11
IC303	D-10
IC304	D-11
IC307	C-8
IC308	E-11
IC309	E-8
IC310	I-7
IC311	E-7
IC312	D-12
IC313	C-12
IC314	D-11
IC316	C-5
Q101	E-11
Q102	D-10
Q301	E-7
Q302	E-7
Q306	F-9
Q307	E-9
Q308	F-11

Note:

- : parts extracted from the component side.
- : parts mounted on the conductor side.
- : Pattern from the side which enable seeing.
- Abbreviation
 - CND : Canadian model.
 - G : German model.
 - SP : Singapore model.
 - HK : Hong Kong model.
 - JE : Tourist model.

5-7. PRINTED WIRING BOARD — PANEL SECTION —
 • See page 30 for Circuit Boards Location.

• Semiconductor Location

Ref. No.	Location
D701	A-12
IC701	B-6
IC702	C-11
Q701	B-11
Q702	B-11

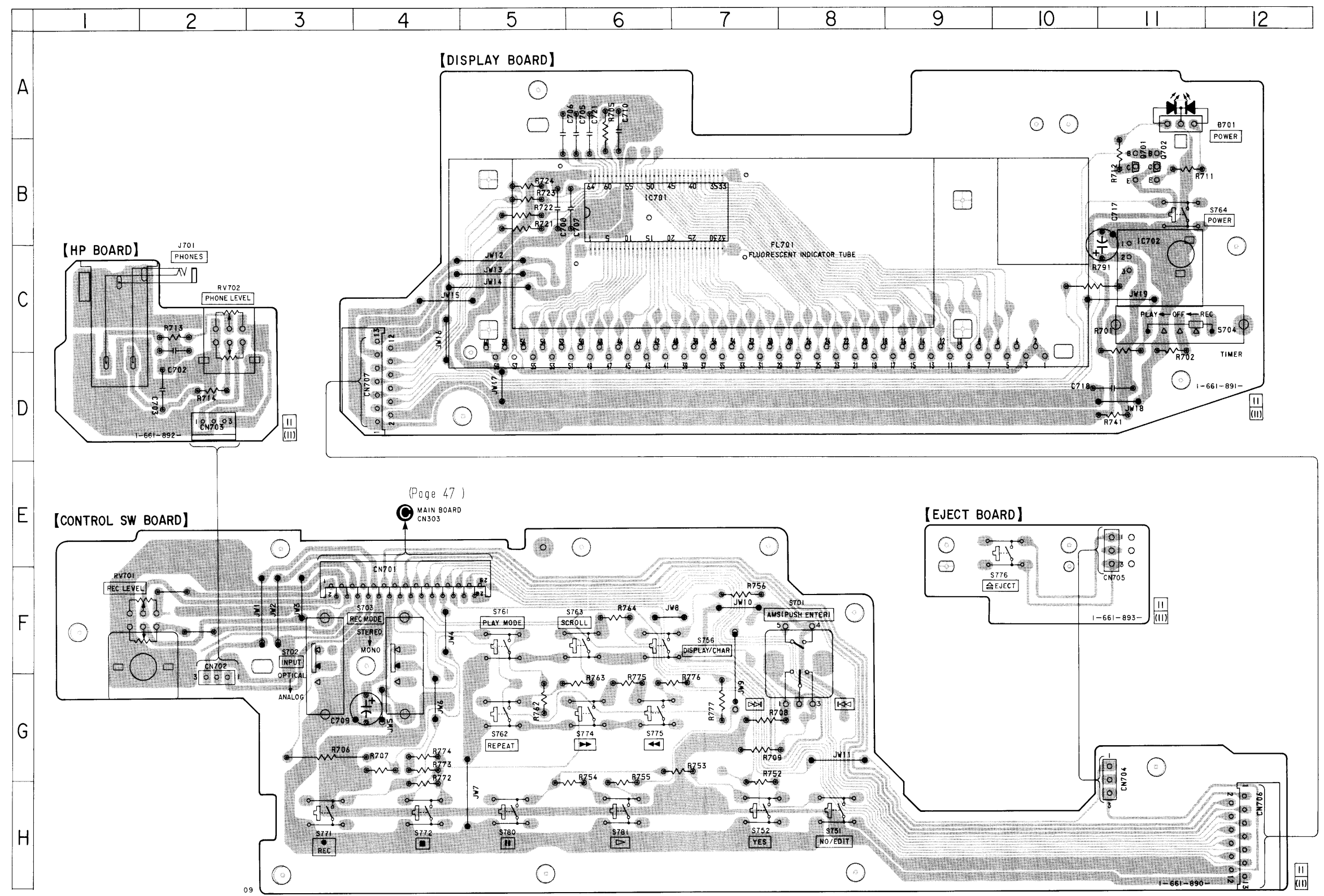

Note:
 • ○ : parts extracted from the component side.
 • ■ : Pattern from the side which enable seeing.

5-8. SCHEMATIC DIAGRAM — PANEL SECTION —

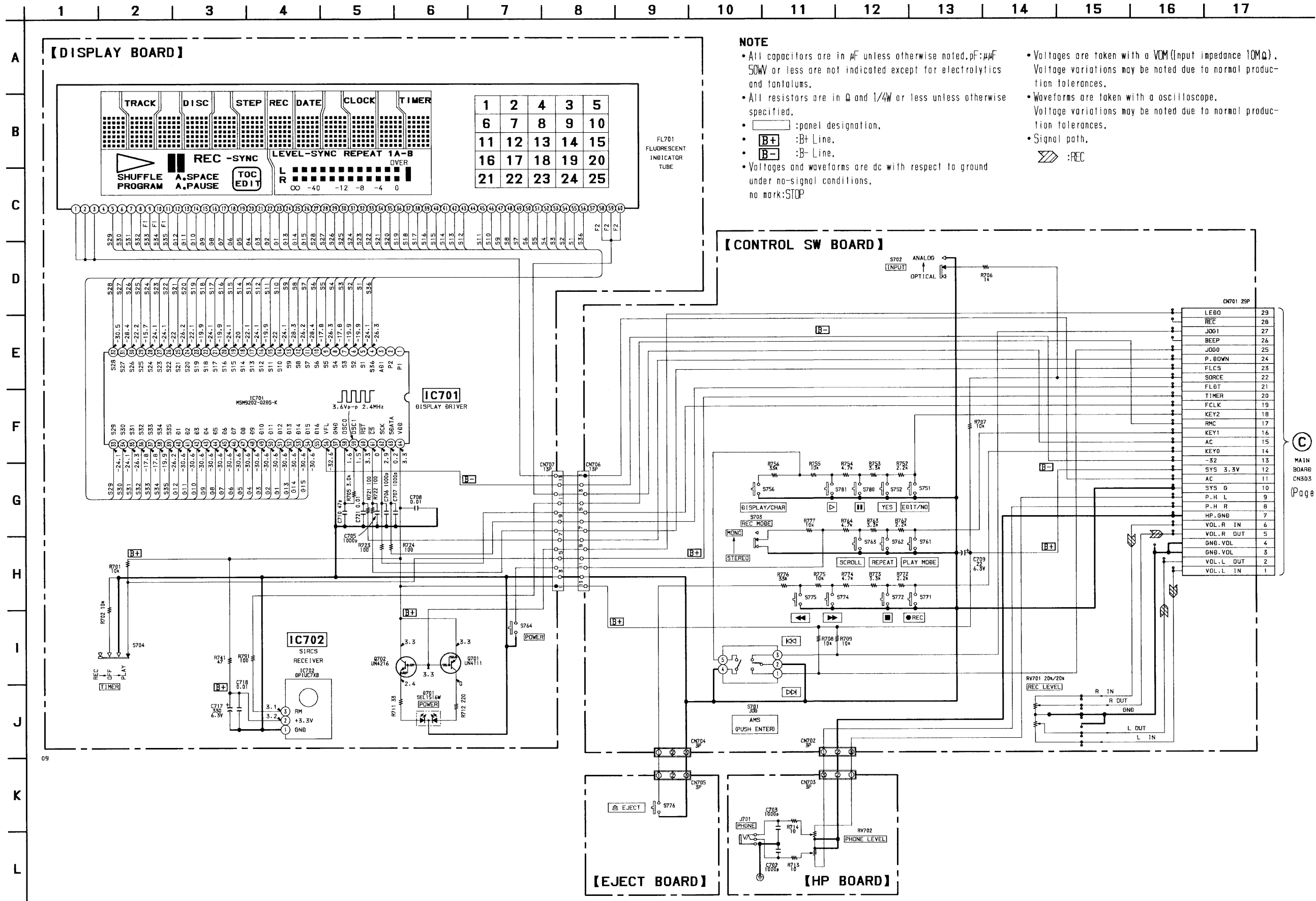

NOTE

- All capacitors are in μF unless otherwise noted, pF: μF 50W or less are not indicated except for electrolytics and tantalums.
- All resistors are in Ω and $1/4W$ or less unless otherwise specified.
- [] : panel designation.
- B+ : B+ Line.
- B- : B- Line.
- Voltages and waveforms are dc with respect to ground under no-signal conditions. no mark: STOP
- Voltages are taken with a VOM (Input impedance $10M\Omega$). Voltage variations may be noted due to normal production tolerances.
- Waveforms are taken with an oscilloscope. Voltage variations may be noted due to normal production tolerances.
- Signal path.

(C) MAIN BOARD CNS03 (Page 44)

5-9. IC Block Diagrams — BD/MAIN Section —

IC101 CXA2523R

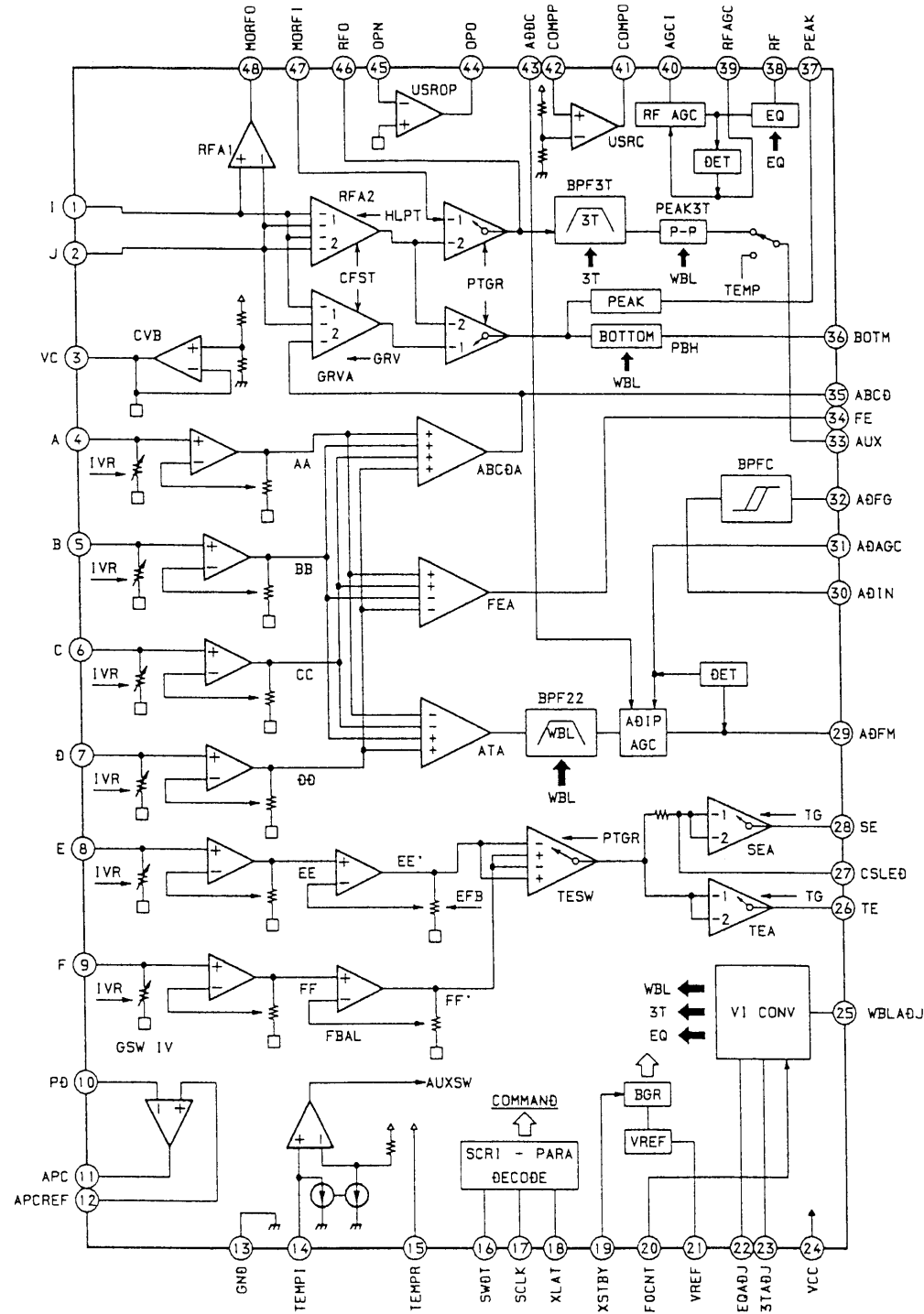

IC121 CXD2650R

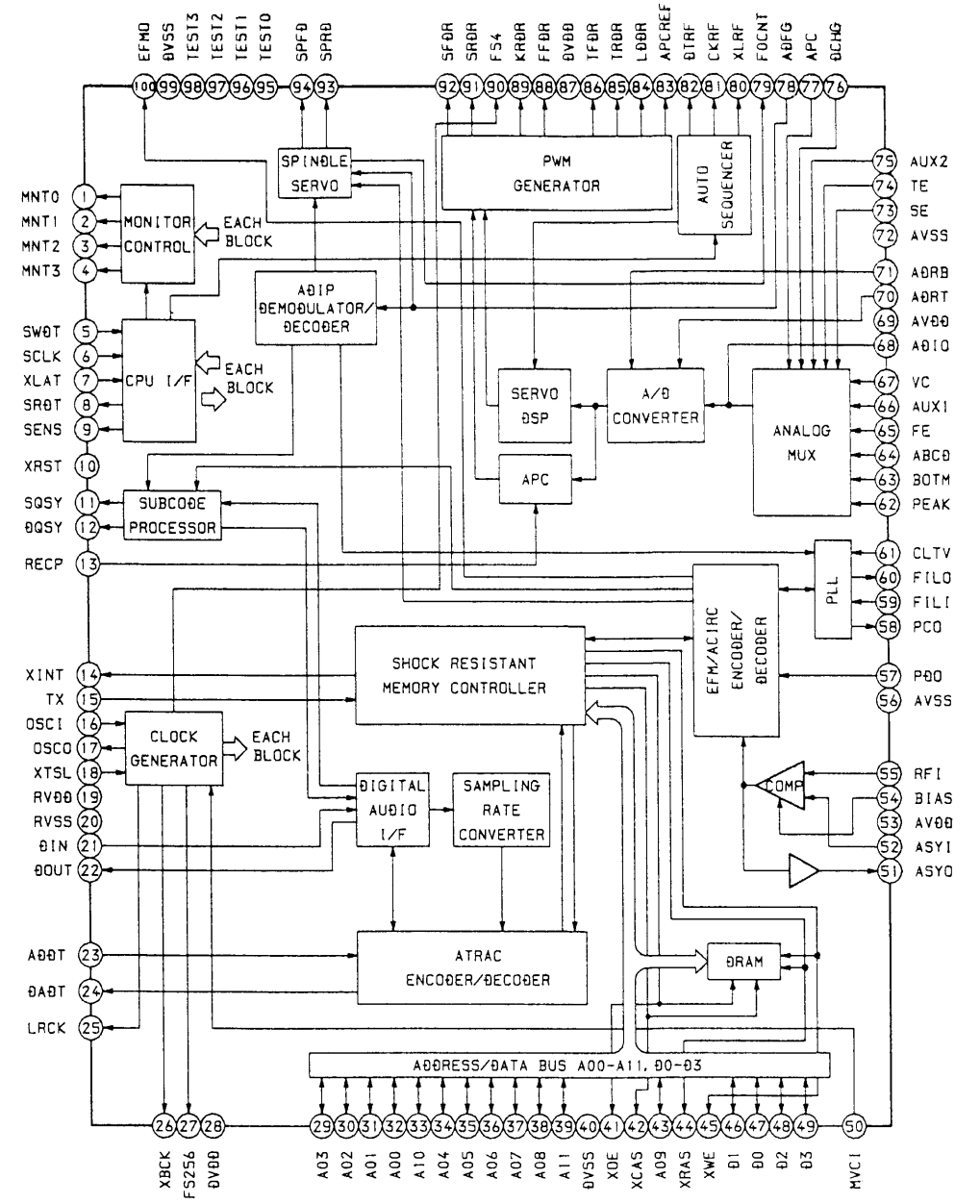

IC152 BH65111FS

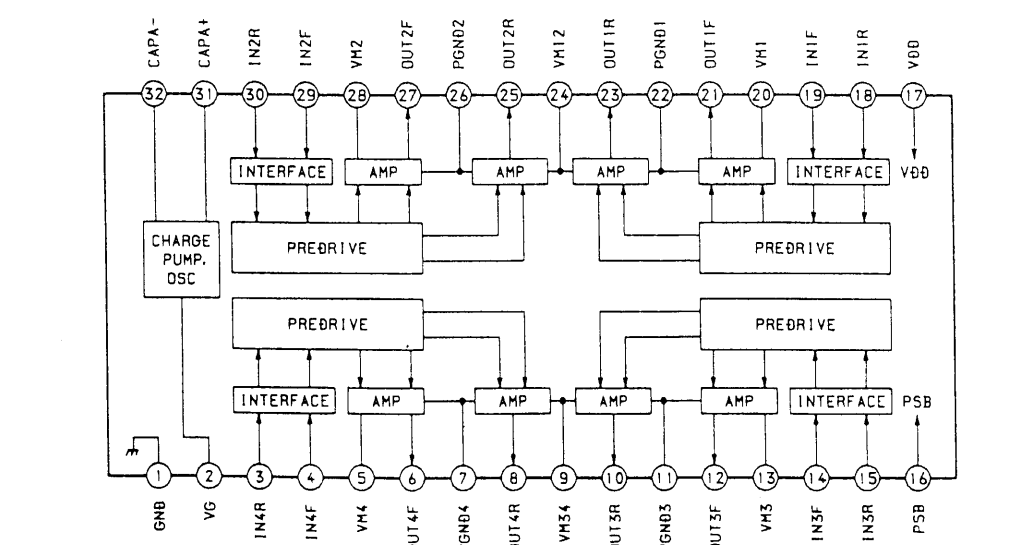

IC301 CXA8065S

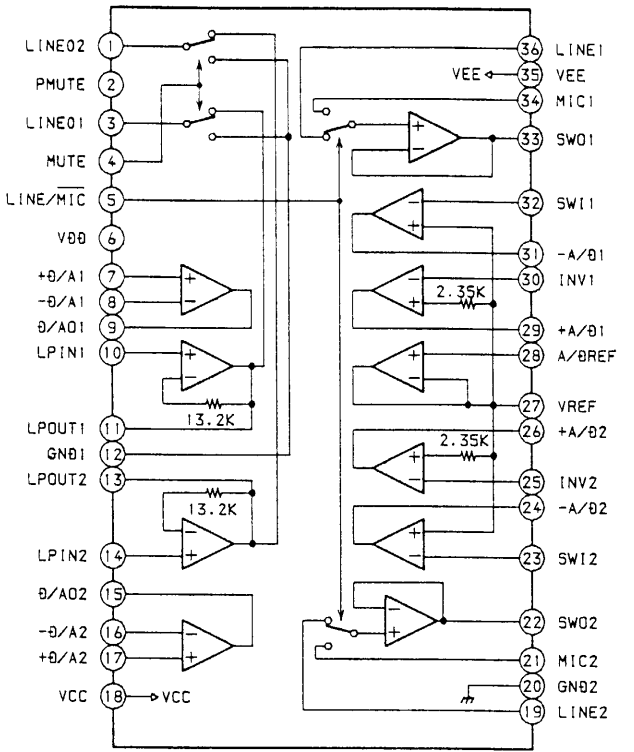

IC307 CXD8607N

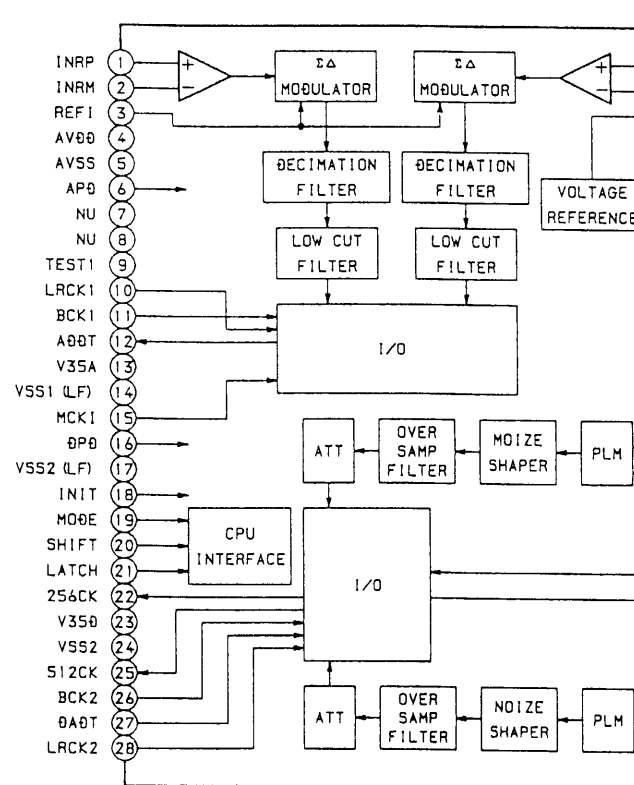

IC308 M5218AL

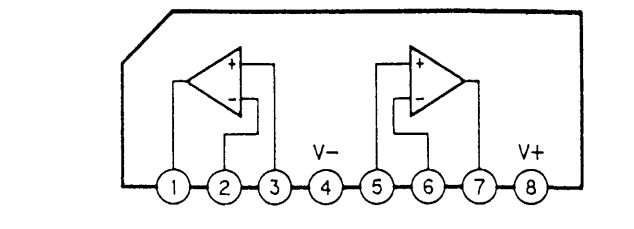

IC309 LA5620

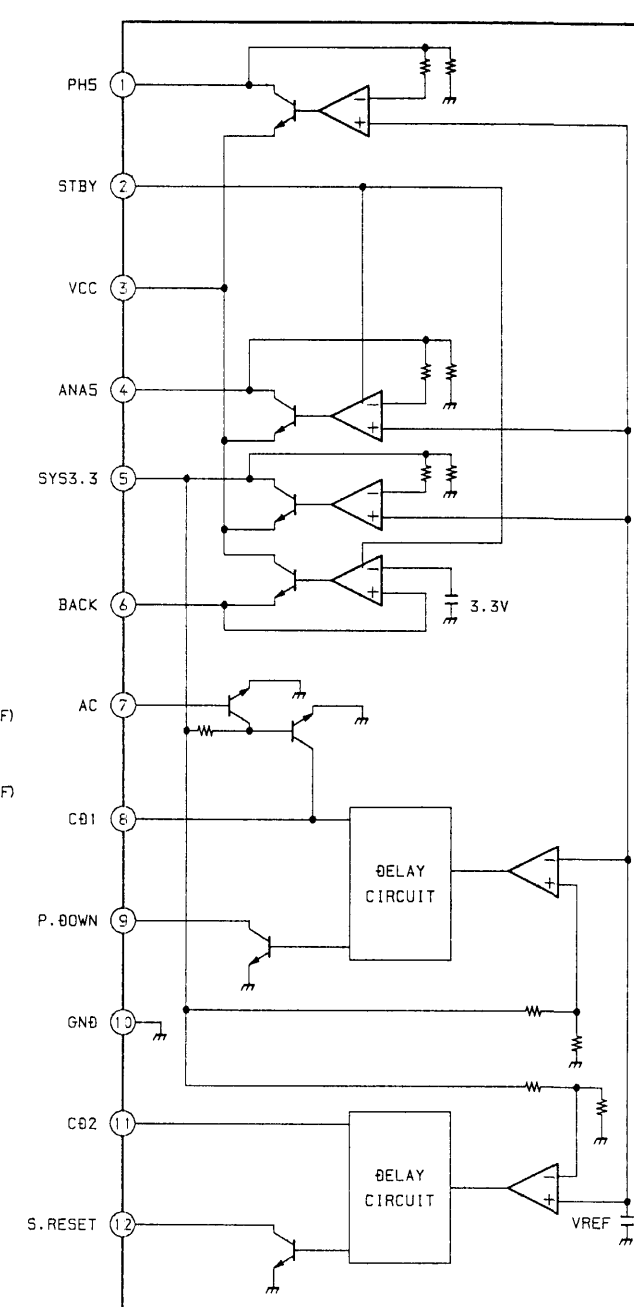

IC310 M5293L

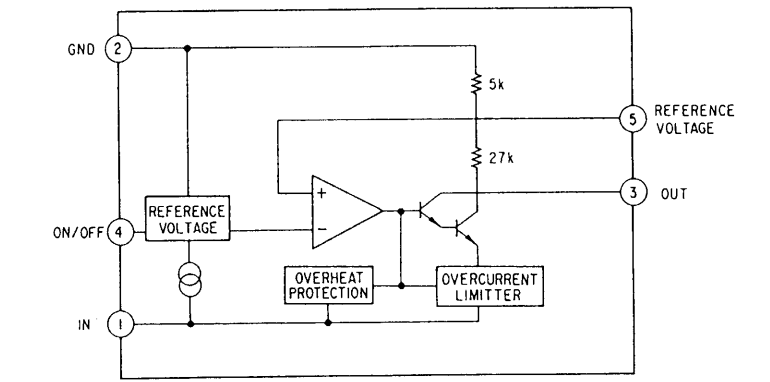

5-10. IC PIN FUNCTIONS

• IC101 RF Amplifier (CXA2523R)

Pin No.	Pin Name	I/O	Function
1	I	I	I-V converted RF signal I input
2	J	I	I-V converted RF signal J input
3	VC	O	Middle point voltage (+1.5V) generation output
4 to 9	A to F	I	Signal input from the optical pick-up dictator
10	PD	I	Light amount monitor input
11	APC	O	Laser APC output
12	APCREF	I	Reference voltage input for setting laser power
13	GND	—	Ground
14	TEMPI	I	Temperature sensor connection
15	TEMPR	O	Reference voltage output for the temperature sensor
16	SWDT	I	Serial data input from the CXD2650R
17	SCLK	I	Serial clock input from the CXD2650R
18	XLAT	I	Latch signal input from the CXD2650R. "L": Latch
19	XSTBY	I	Stand by signal input. "L": Stand by
20	F0CNT	I	Center frequency control voltage input of BFF22, BPF3T, EQ from the CXD2650R
21	VREF	O	Reference voltage output (Not used)
22	EQADJ	I/O	Center frequency setting pin for the internal circuit EQ
23	3TADJ	I/O	Center frequency setting pin for the internal circuit BPF3T
24	Vcc	—	+3V power supply
25	WBLADJ	I/O	Center frequency setting pin for the internal circuit BPF22
26	TE	O	Tracking error signal output to the CXD2650R
27	CSLED	—	External capacitor connection pin for the sled error signal LPF
28	SE	O	Sled error signal output to the CXD2650R
29	ADFM	O	FM signal output of ADIP
30	ADIN	I	ADIP signal comparator input. ADFM is connected with AC coupling
31	ADAGC	—	External capacitor connection pin for AGC of ADIP
32	ADFG	O	ADIP duplex signal output to the CXD2650R
33	AUX	O	I ₃ signal/temperature signal output to the CXD2650R (Switching with a serial command)
34	FE	O	Focus error signal output to the CXD2650R
35	ABCD	O	Light amount signal output to the CXD2650R
36	BOTM	O	RF/ABCD bottom hold signal output to the CXD2650R
37	PEAK	O	RF/ABCD peak hold signal output to the CXD2650R
38	RF	O	RF equalizer output to the CXD2650R
39	RFAGC	—	External capacitor connection pin for the RF AGC circuit
40	AGCI	I	Input to the RF AGC circuit. The RF amplifier output is input with AC coupling
41	COMPO	O	User comparator output (Not used)
42	COMPP	I	User comparator input (Fixed at "L")
43	ADDC	I/O	External capacitor pin for cutting the low band of the ADIP amplifier
44	OPO	O	User operation amplifier output (Not used)
45	OPN	I	User operation amplifier inversion input (Fixed at "L")
46	RFO	O	RF amplifier output
47	MORFI	I	Groove RF signal is input with AC coupling
48	MORFO	O	Groove RF signal output

• Abbreviation

APC: Auto Power Control

AGC: Auto Gain Control

• IC121 Digital Signal Processor, Digital Servo Signal Processor, EFM/ACIRC Encoder/Decoder, Shock-proof Memory Controller, ATRAC Encoder/Decoder, 2M Bit DRAM (CXD2650R)

Pin No.	Pin Name	I/O	Function
1	MNT0 (FOK)	O	FOK signal output to the system control "H" is output when focus is on
2	MNT1 (SHCK)	O	Track jump detection signal output to the system control
3	MNT2 (XBUSY)	O	Monitor 2 output to the system control
4	MNT3 (SLOC)	O	Monitor 3 output to the system control
5	SWDT	I	Writing data signal input from the system control
6	SCLK	I (S)	Serial clock signal input from the system control
7	XLAT	I (S)	Serial latch signal input from the system control
8	SRDT	O (3)	Reading data signal output to the system control
9	SENS	O (3)	Internal status (SENSE) output to the system control
10	XRST	I (S)	Reset signal input from the system control. "L": Reset
11	SQSY	O	Subcode Q sync (SCOR) output to the system control "L" is output every 13.3 msec. Almost all, "H" is output
12	DQSY	O	Digital In U-bit CD format subcode Q sync (SCOR) output to the system control "L" is output every 13.3 msec. Almost all, "H" is output
13	RECP	I	Laser power switching input from the system control. "H": Recording, "L": Playback
14	XINT	O	Interrupt status output to the system control
15	TX	I	Recording data output enable input from the system control
16	OSCI	I	System clock input (512Fs=22.5792 MHz)
17	OSCO	O	System clock output (512Fs=22.5792 MHz) (Not used)
18	XTSL	I	System clock frequency setting. "L": 45.1584 MHz, "H": 22.5792 MHz (Fixed at "H")
19	DVDD	-	+3V power supply (Digital)
20	DVSS	-	Ground (Digital)
21	DIN	I	Digital audio input (Optical input)
22	DOUT	O	Digital audio output (Optical output)
23	ADDT	I	Data input from the A/D converter
24	DADT	O	Data output to the D/A converter
25	LRCK	O	LR clock output for the A/D and D/A converter (44.1 kHz)
26	XBCK	O	Bit clock output to the A/D and D/A converter (2.8224 MHz)
27	FS256	O	11.2896 MHz clock output (Not used)
28	DVDD	-	+3V power supply (Digital)
29 to 32	A03 to A00	O	} DRAM address output (Not used)
33	A10		
34 to 38	A04 to A08		
39	A11		
40	DVSS	-	Ground (Digital)
41	XOE	O	Output enable output for DRAM (Not used)
42	XCAS	O	CAS signal output for DRAM (Not used)
43	A09	O	Address output for DRAM (Not used)
44	XRAS	O	RAS signal output for DRAM (Not used)
45	XWE	O	Write enable signal output for DRAM (Not used)

* I (S) stands for Schmidt input, I (A) for analog input, O (3) for 3-state output, and O (A) for analog output in the column I/O

Pin No.	Pin Name	I/O	Function
46	D1	I/O	Data input/output for DRAM (Not used)
47	D0	I/O	
48, 49	D2, D3	I/O	
50	MVCI	I (S)	Clock input from an external VCO (Fixed at "L")
51	ASYO	O	Playback EFM duplex signal output
52	ASYI	I (A)	Playback EFM comparator slice level input
53	AVDD	-	+3V power supply (Analog)
54	BIAS	I (A)	Playback EFM comparator bias current input
55	RFI	I (A)	Playback EFM RF signal input
56	AVSS	-	Ground (Analog)
57	PDO	O (3)	Phase comparison output for the clock playback analog PLL of the playback EFM (Not used)
58	PCO	O (3)	Phase comparison output for the recording/playback EFM master PLL
59	FILI	I (A)	Filter input for the recording/playback EFM master PLL
60	FILO	O (A)	Filter output for the recording/playback EFM master PLL
61	CLTV	I (A)	Internal VCO control voltage input for the recording/playback EFM master PLL
62	PEAK	I (A)	Light amount signal peak hold input from the CXA2523R
63	BOTM	I (A)	Light amount signal bottom hold input from the CXA2523R
64	ABCD	I (A)	Light amount signal input from the CXA2523R
65	FE	I (A)	Focus error signal input from the CXA2523R
66	AUX1	I (A)	Auxiliary A/D input
67	VC	I (A)	Middle point voltage (+1.5V) input from the CXA2523R
68	ADIO	O (A)	Monitor output of the A/D converter input signal (Not used)
69	AVDD	-	+3V power supply (Analog)
70	ADRT	I (A)	A/D converter operational range upper limit voltage input (Fixed at "H")
71	ADRB	I (A)	A/D converter operational range lower limit voltage input (Fixed at "L")
72	AVSS	-	Ground (Analog)
73	SE	I (A)	Sled error signal input from the CXA2523R
74	TE	I (A)	Tracking error signal input from the CXA2523R
75	AUX2	I (A)	Auxiliary A/D input (Fixed at "L")
76	DCHG	I (A)	Connected to +3V power supply
77	APC	I (A)	Error signal input for the laser digital APC (Fixed at "L")
78	ADFG	I (S)	ADIP duplex FM signal input from the CXA2523R (22.05 ± 1 kHz)
79	FOCNT	O	Filter fo control output from the CXA2523R
80	XLRF	O	Control latch output from the CXA2523R
81	CKRF	O	Control clock output from the CXA2523R
82	DTRF	O	Control data output from the CXA2523R
83	APCREF	O	Reference PWM output for the laser APC
84	LDDR	O	PWM output for the laser digital APC (Not used)
85	TRDR	O	Tracking servo drive PWM output (-)

- Abbreviation
EFM: Eight to Fourteen Modulation
PLL : Phase Locked Loop
VCO: Voltage Controlled Oscillator

Pin No.	Pin Name	I/O	Function
86	TFDR	O	Tracking servo drive PWM output (+)
87	DVDD	-	+3V power supply (Digital)
88	FFDR	O	Focus servo drive PWM output (+)
89	FRDR	O	Focus servo drive PWM output (-)
90	FS4	O	176.4 kHz clock signal output (X'tal) (Not used)
91	SRDR	O	Sled servo drive PWM output (-)
92	SFDR	O	Sled servo drive PWM output (+)
93	SPRD	O	Spindle servo drive PWM output (-)
94	SPFD	O	Spindle servo drive PWM output (+)
95	TEST0	I (S)	} Test input (Fixed at "L")
96 to 98	TEST1 to TEST3	I	
99	DVSS	-	Ground (Digital)
100	EFMO	O	EFM output when recording

- Abbreviation
EFM: Eight to Fourteen Modulation

• IC307 A/D, D/A converter (CXD8607N)

Pin No.	Pin Name	I/O	Function
1	INRP	I	Rch analog (+) input
2	INRM	I	Rch analog (-) input
3	REFI	I	A/D reference voltage input (+3.2V)
4	AVDD	-	+5V power supply (A/D, analog)
5	AVSS	-	Ground (A/D, analog)
6	APD	I	A/D analog block power down. "L": Power down
7	NU	-	} Not used
8	NU	-	
9	TEST1	I	Test pin (Fixed at "L")
10	LRCK1	I	A/D LRCK input
11	BCK1	I	A/D BCK input
12	ADDT	O	A/D data output
13	V35A	-	+3.3V power supply
14	VSS1 (LF)	-	Ground (A/D, digital)
15	MCKI	I	A/D master clock input (256 fs)
16	DPD	I	A/D digital block power down. "L": Power down/reset
17	VSS2 (LF)	-	Ground (D/A, digital)
18	INIT	I	D/A initialize. "L": Initialize
19	MODE	I	Mode flag input
20	SHIFT	I	Shift clock input
21	LATCH	I	Latch clock input
22	256CK	O	256 fs clock output
23	V35D	-	+3.3V power supply
24	VSS2	-	Ground (D/A, digital)
25	512CK	O	512 fs clock output
26	BCK2	I	D/A BCK input
27	DADT	I	D/A data input
28	LRCK2	I	D/A LRCK input
29	VDD2	-	+5V power supply (D/A, digital)
30	R1	O	Rch PLM output 1
31	AVDDR	-	+5V power supply (D/A, Rch, analog)
32	R2	O	Rch PLM output 2
33	AVSSR	-	Ground (D/A, Rch, analog)
34	XVDD	-	+5V power supply (X'tal)
35	XOUT	O	X'tal oscillation output (22 MHz)
36	XIN	I	X'tal oscillation input (512 fs) (22 MHz)
37	XVSS	-	Ground (X'tal)
38	AVSSL	-	Ground (D/A, Lch, analog)
39	L2	O	Lch PLM output 2
40	AVDDL	-	+5V power supply (D/A, Lch, analog)

Pin No.	Pin Name	I/O	Function
41	L1	O	Lch PLM output 1
42	VDD2	-	+5V power supply (D/A, digital)
43	VDD1	-	} +5V power supply (A/D, digital)
44	VDD1	-	
45	VSS1	-	Ground (A/D, digital)
46	TEST2	I	} Test pin (Fixed at "L")
47	TEST3	I	
48	VSS1 (LF)	-	Ground (A/D, digital)
49	NU	-	} Not used
50	NU	-	
51	AVSS (LF)	-	Ground (A/D, analog)
52	LVDD	-	+5V power supply (A/D, buffer)
53	LVSS	-	Ground (A/D, buffer)
54	REFO	O	A/D reference voltage output (+3.2V)
55	INLM	I	Lch analog (-) input
56	INLP	I	Lch analog (+) input

• IC316 System Control (RU8X11AMF-0101)

Pin No.	Pin Name	I/O	Function
1	(DAOUT 0)	O	Test pin. C1 is output when test mode (Not used)
2	(DAOUT 1)	O	Test pin. ADER is output when test mode (Not used)
3 to 5	KEY 0~KEY 2	I	Key input pin (D/A input)
6	CHACK IN	I	Detection input from the chucking-in switch. "L": Chucking
7	PACK IN	I	Detection input from the disk detection switch (Not used)
8	PACK OUT	I	Detection input from the loading out switch. Loaded out position: "L", Others: "H"
9	TIMER REC/PLAY	I	Timer recording/playback/off select input Recording: "H", playback: "L", OFF: middle point voltage (1.6V)
10	SORCE	I	Input signal (analog/digital input) select signal input Analog input: "H", digital input: "L"
11	AVSS	—	Ground (analog)
12	XINT	I	Interrupt status input from the CXD2650R
13	POWER DOWN	I	POWER DOWN signal input. "L": Down
14	REMOCON	I	Remote control signal interrupt input
15	SQSY	I	ATP addressing or subcode Q sync (SCOR) input from the CXD2650R "L" is input every 13.3 msec. Almost all, "H"
16	DQSY	I	Digital-In U-bit CD format subcode Q sync (SCOR) input from the CXD2650R "L" is input every 13.3 msec. Almost all, "H"
17	—	O	} Not used
18	—	O	
19	—	O	
20	SYSTEM RST	I	System reset signal input For several hundreds msec after the power supply rises, "L" is input, then it changes to "H"
21	(TEST)	I	Test pin (Fixed at "L")
22	+3.3V	—	+3.3V power supply
23	V BAT	—	Power supply pin to RTC (clock) and RAM
24	XOUT T	O	Clock output (32.768 kHz) (For clock)
25	XIN T	I	Clock input (32.768 kHz) (For clock)
26	GND	—	Ground
27	XOUT	O	Main clock output (12 MHz)
28	XIN	I	Main clock input (12 MHz)
29	GND	—	Ground
30	—	O	} Not used
31	—	O	
32	SENS	I	Internal status (SENSE) input from the CXD2650R
33	SHOCK	I	Track jump signal input from the CXD2650R
34	REC/OTHER	I	BEEP sound output select signal input (Not used)
35	—	I	Not used
36	STB	O	Strobe signal output to the power supply circuit. Power supply ON: "H", stand by: "L"
37	REC P	I	Detection signal input from the recording position detection switch
38	PB P	I	Detection signal input from the playback position detection switch
39	LD LOW	O	Loading motor voltage control output
40	—	O	Not used

Pin No.	Pin Name	I/O	Function
41	MNT2	I	Monitor 2 input from the CXD2650
42	MNT3	I	Monitor 3 input from the CXD2650
43	LED0	O	Drive output to the POWER display LED (D701) Power supply ON: "H", stand by: "L"
44	—	I	} Not used
45	—	I	
46	BUS OUT	O	Audio-bus output (Not used) (Fixed at "L")
47	GND	—	Ground
48	+3.3V	—	+3.3V power supply
49	BEEP SW	I	Input from the BEEP sound output ON/OFF switch (Not used)
50, 51	JOG 1, JOG 0	I	JOG dial pulse input from the rotary encoder (S701)
52	SDA	I/O	Data signal input/output pin with the backup memory
53	SCL	O	Clock signal output to the backup memory
54	—	O	} Not used
55	—	O	
56	—	O	
57	—	I	
58	—	O	
59	AUBK	I	Audio bus connection check signal input (Not used)
60	SA/SW	O	Audio bus/remote control switching signal output (Not used)
61	—	I	} Not used
62	—	O	
63	CLKSET0	I	} Clock destination select pin (Fixed at "L")
64	CLKSET1	I	
65	GND	—	Ground
66	+3.3V	—	+3.3V power supply
67	SCLK	O	Clock signal output to the serial bus
68	SWDT	O	Writing data signal output to the serial bus
69	SRDT	I	Reading data signal input from the serial bus
70	—	I	Not used
71	FLCLK	O	Serial clock signal output to the display driver
72	FLDATA	O	Serial data signal output to the display driver
73	FLCS	O	Chip select signal output to the display driver
74	—	I	Not used (Fixed at "L")
75	LDON	O	Laser ON/OFF control output. "H": Laser ON
76	PIT/GRV	I	Pit/groove detection input. "H" is input for the playback only disk or TOC area (Not used) (Fixed at "L")
77	FOK	I	FOK signal input from the CXD2650R "H" is input when focus is on
78	—	I	Not used
79	LOCK	O	Not used (Fixed at "L")
80	WRPWR	O	Laser power switching signal output to the optical pick-up and CXD2650R

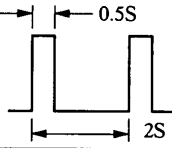
Pin No.	Pin Name	I/O	Function
81	DIG RST	O	Reset signal output to the CXD2650R and motor driver. Reset: "L"
82	BEEP	O	BEEP PWM output (Not used) (Fixed at "L")
83	DA RST	O	Reset signal output to the D/A, A/D converter. Reset: "L"
84, 85	—	O	Not used
86	MOD	O	Laser modulation switching signal output Playback power: "L", stop: "H" Recording power: 
87	—	O	} Not used
88	—	O	
89	SCTX	O	Writing data transmission timing output to the CXD2650R Shared with the magnetic head ON/OFF output
90	XLATCH	O	Latch signal output to the serial bus
91	—	O	} Not used
92	—	O	
93	AMUTE	O	Line out muting output
94	LDOUT	O	} Loading motor control output *1
95	LDIN	O	
96	LIMIT IN	I	Detection input from the limit-In switch Sled limit-In: "L"
97	PROTECT	I	Recording-protection claw detection input from the protection detection switch. Protect: "H"
98	REFLECT	I	Disk reflection rate detection input from the reflect detection switch Disk with low reflection rate: "H"
99	GND	—	Ground
100	+3.3V	—	+3.3V power supply

* 1 Loading motor control

Operation Pin	IN	OUT	Brake
LDIN 95 pin	"H"	"L"	"H"
LDOUT 94 pin	"L"	"H"	"H"

SECTION 6 EXPLODED VIEWS

NOTE:

- Items marked “* ” are not stocked since they are seldom required for routine service. Some delay should be anticipated when ordering these items.
- The mechanical parts with no reference number in the exploded views are not supplied.
- Color Indication of Appearance Parts Example:
KNOB, BALANCE (WHITE)
↑
Cabinet's color

- Hardware (# mark) list and accessories and packing materials are given in the last of this parts list.
- Abbreviation
CND : Canadian model
G : German model
HK : Hong Kong model
SP : Singapore model
JE : Tourist model

The components identified by mark Δ or dotted line with mark Δ are critical for safety.
Replace only with part number specified.

Les composants identifiés par une marque Δ sont critiques pour la sécurité.
Ne les remplacer que par une pièce portant le numéro spécifié.

6-1. CASE SECTION

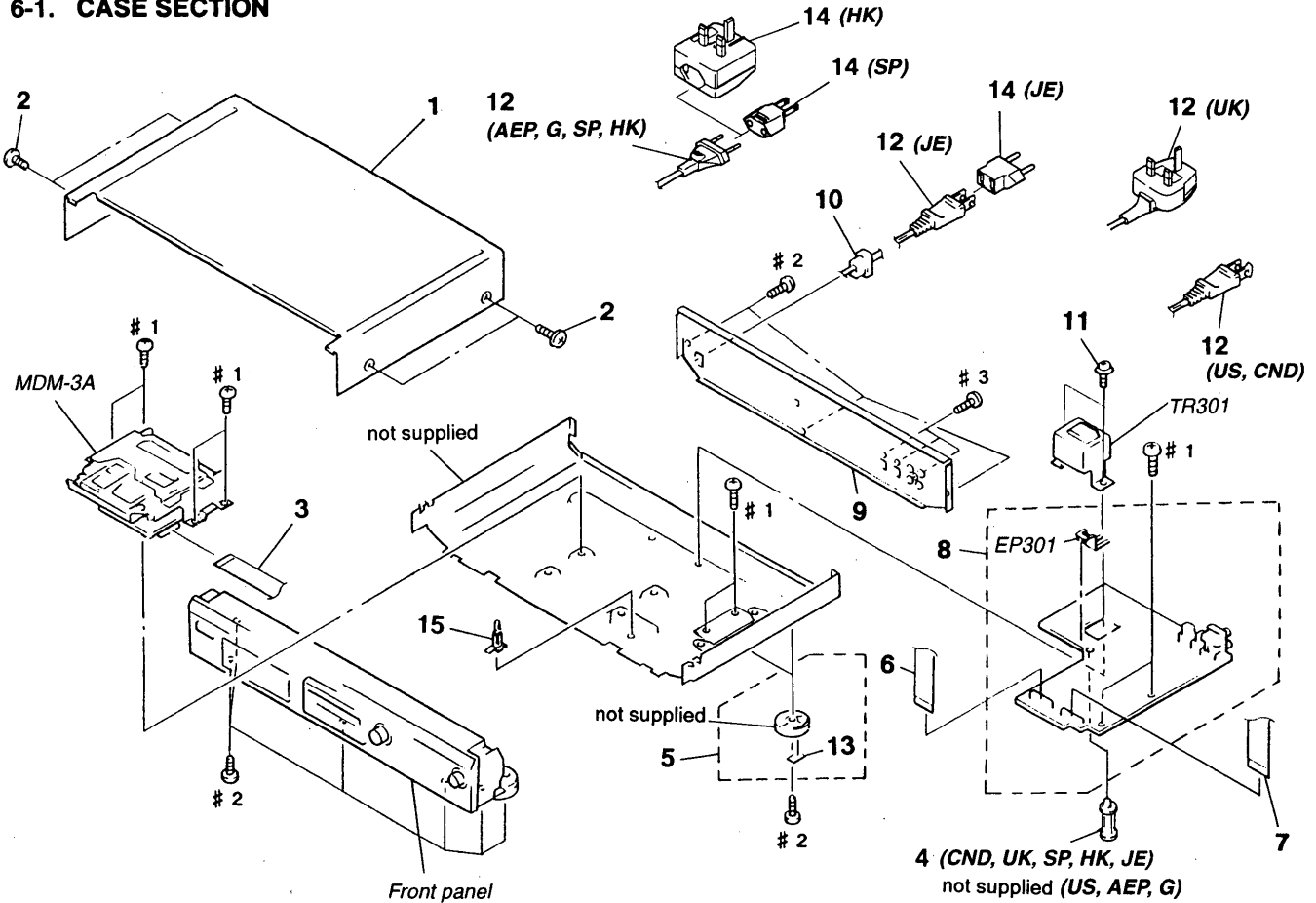

Ref. No.	Part No.	Description	Remark
* 1	4-983-661-01	CASE (408226) (BLACK)	
* 1	4-983-661-41	CASE (408226) (SILVER)	
2	3-363-099-11	SCREW (CASE 3 TP2) (SILVER)	
2	3-704-366-01	SCREW (CASE) (M3X8) (BLACK)	
3	1-777-278-11	WIRE (FLAT TYPE) (19 CORE)	
* 4	3-350-847-41	HOLDER, PCB (CND, UK, SP, HK, JE)	
5	X-4947-389-1	FOOT ASSY (F50150S) (BLACK) (EXCEPT US, CND)	
5	X-4947-390-2	FOOT ASSY (F50150S) (BLACK) (US, CND)	
5	X-4947-748-1	FOOT ASSY (F50150S) (SILVER)	
6	1-777-275-11	WIRE (FLAT TYPE) (29 CORE)	
7	1-777-276-11	WIRE (FLAT TYPE) (29 CORE)	
* 8	A-4699-146-A	MAIN BOARD, COMPLETE (AEP, G, UK, HK)	
* 8	A-4699-147-A	MAIN BOARD, COMPLETE (SP, JE)	
* 8	A-4699-273-A	MAIN BOARD, COMPLETE (US, CND)	
* 9	4-983-660-11	PANEL, BACK (US)	
* 9	4-983-660-21	PANEL, BACK (CND)	
* 9	4-983-660-31	PANEL, BACK (AEP, G)	
* 9	4-983-660-41	PANEL, BACK (UK)	
* 9	4-983-660-51	PANEL, BACK (SP, JE)	

Ref. No.	Part No.	Description	Remark
* 9	4-983-660-61	PANEL, BACK (HK)	
* 10	3-703-244-00	BUSHING (2104), CORD (EXCEPT US, CND)	
* 10	3-703-571-11	BUSHING (S) (4516), CORD (US, CND)	
11	4-886-821-11	SCREW, S TIGHT, +PTIWH 3X6	
Δ 12	1-558-945-21	CORD, POWER (POLAR. SPT-1) (US, CND)	
Δ 12	1-696-027-11	CORD, POWER (JE)	
Δ 12	1-696-586-21	CORD, POWER (UK)	
Δ 12	1-751-275-11	CORD, POWER (AEP, G, SP, HK)	
13	4-983-762-02	CUSHION	
Δ 14	1-569-007-11	ADAPTOR, CONVERSION 2P (JE)	
Δ 14	1-569-008-11	ADAPTOR, CONVERSION 2P (SP)	
Δ 14	1-770-019-11	ADAPTOR, CONVERSION PLUG 3P (HK)	
* 15	3-703-353-05	SUPPORT, PC BOARD	
* EP301	4-962-200-01	PLATE (TR), GROUND	
Δ TR301	1-429-735-11	TRANSFORMER, POWER (US, CND)	
Δ TR301	1-429-736-11	TRANSFORMER, POWER (AEP, G, UK, HK)	
Δ TR301	1-429-737-11	TRANSFORMER, POWER (SP, JE)	

6-2. FRONT PANEL SECTION

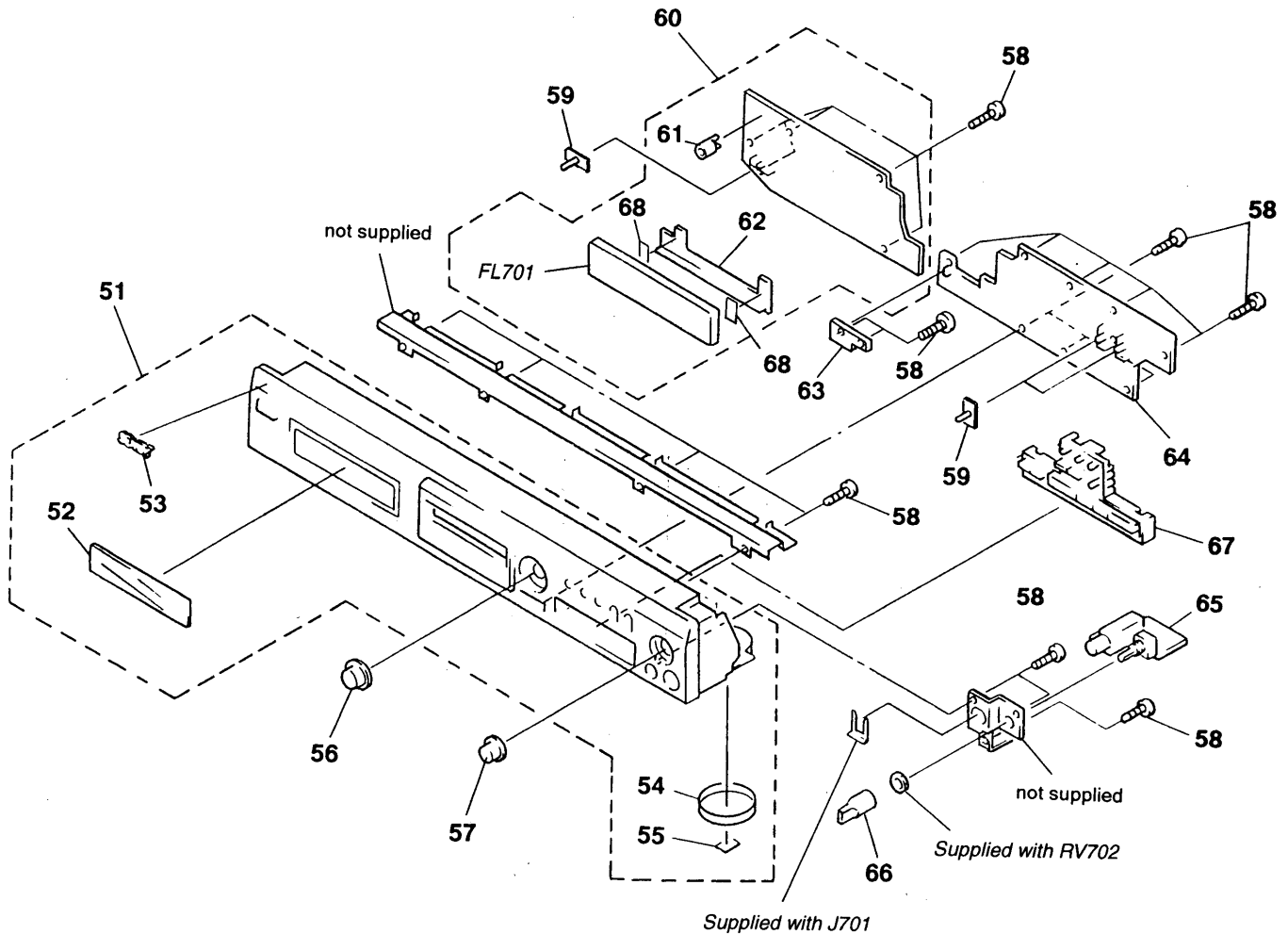

Ref. No.	Part No.	Description	Remark	Ref. No.	Part No.	Description	Remark
51	X-4947-375-2	PANEL ASSY, FRONT (BLACK) (EXCEPT US, CND)		59	3-917-216-11	KNOB (TIMER) (BLACK)	
51	X-4947-377-2	PANEL ASSY, FRONT (BLACK) (US, CND)		* 60	A-4699-141-A	DISPLAY BOARD, COMPLETE	
51	X-4947-745-1	PANEL ASSY, FRONT (SILVER)		* 61	4-972-608-01	HOLDER (DIA. 5), LED	
* 52	4-983-651-01	WINDOW (DISPLAY)		* 62	4-983-462-01	HOLDER (FL)	
53	4-963-404-21	EMBLEM (5-A), SONY		* 63	1-661-893-11	EJECT SW BOARD	
54	4-981-435-11	RING (DIA. 50), ORNAMENTAL (EXCEPT US, CND)		* 64	A-4699-142-A	CONTROL SW BOARD, COMPLETE	
55	4-983-762-02	CUSHION		* 65	1-661-892-11	HP BOARD	
56	4-983-657-01	KNOB (AMS) (BLACK)		66	4-950-189-01	KNOB (A) (VOL) (BLACK)	
56	4-983-657-31	KNOB (AMS) (SILVER)		66	4-950-189-31	KNOB (A) (VOL) (SILVER)	
57	4-983-656-01	KNOB (REC) (BLACK)		67	4-983-653-01	BUTTON (MAIN) (BLACK)	
57	4-983-656-21	KNOB (REC) (SILVER)		67	4-983-653-21	BUTTON (MAIN) (SILVER)	
58	4-951-620-01	SCREW (2. 6X8), +BVTP		68	2-389-320-01	CUSHION	
59	3-917-216-02	KNOB (TIMER) (SILVER)		FL701	1-517-575-11	INDICATOR TUBE, FLUORESCENT	

6-3. MECHANISM DECK SECTION (1) (MDM-3A)

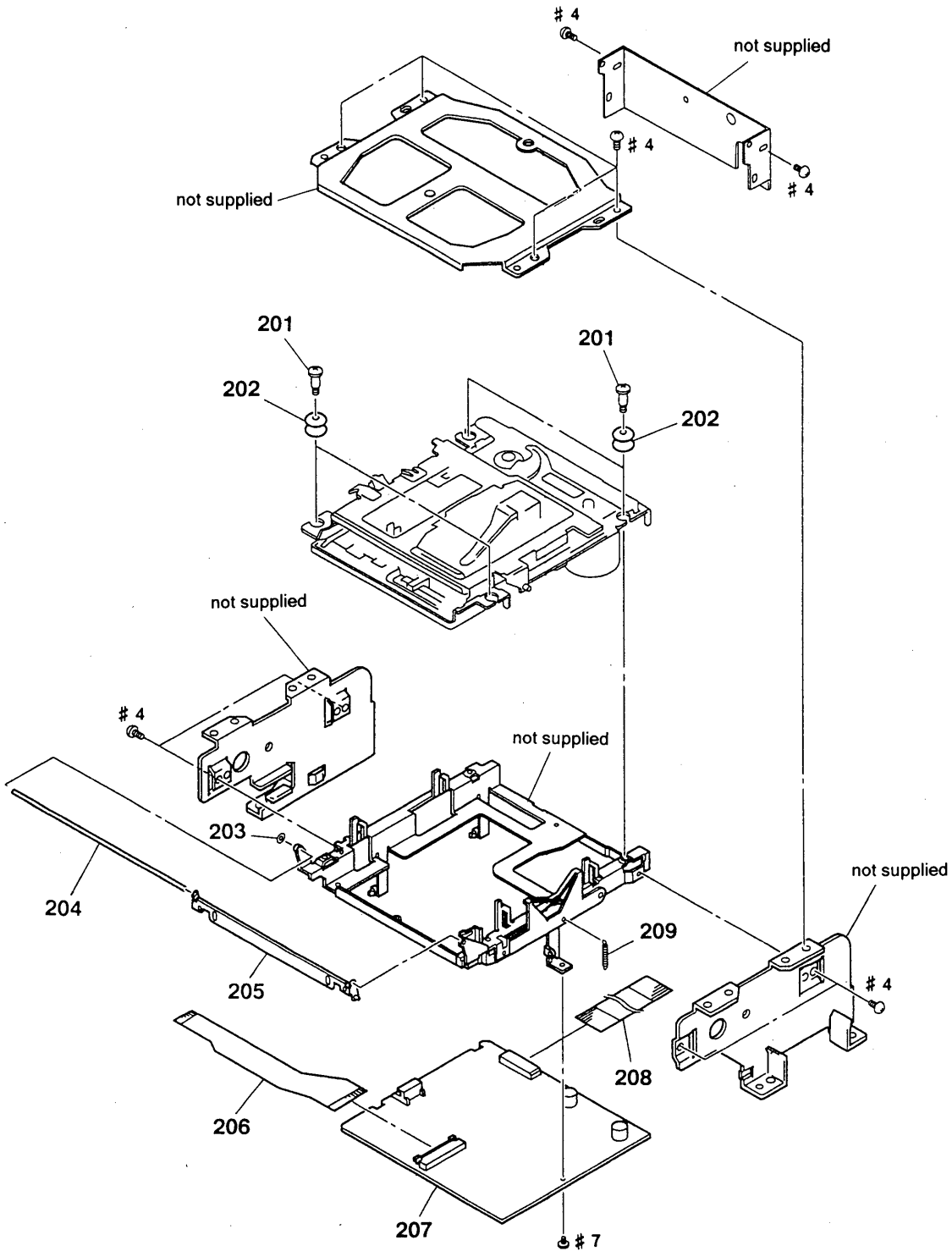

Ref. No.	Part No.	Description	Remark	Ref. No.	Part No.	Description	Remark
201	4-628-167-01	SCREW, STEP		206	1-660-966-11	OP RELAY FLEXIBLE BOARD	
202	4-987-327-01	INSULATOR		* 207	A-4699-092-A	BD BOARD, COMPLETE	
203	4-986-959-01	WASHER, STOPPER		208	1-777-517-11	WIRE (FLAT TYPE) (15 CORE)	
204	4-979-904-01	SHAFT (SHUTTER) (A)		209	4-987-910-01	SPRING, TORSION (O/C)	
205	X-4947-825-1	SHUTTER ASSY					

6-4. MECHANISM DECK SECTION (2) (MDM-3A)

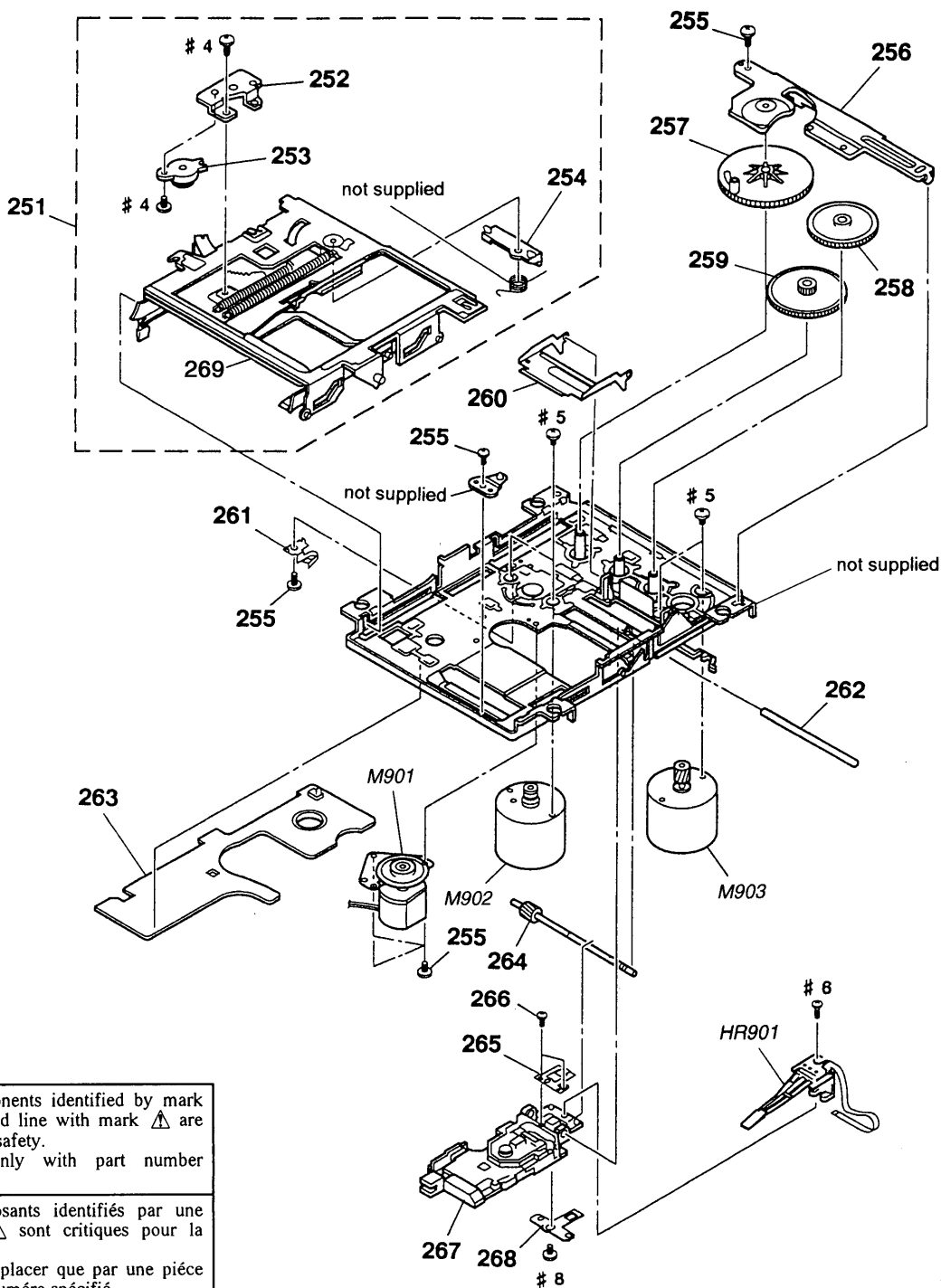

The components identified by mark \triangle or dotted line with mark \triangle are critical for safety. Replace only with part number specified.

Les composants identifiés par une marque \triangle sont critiques pour la sécurité. Ne les remplacer que par une pièce portant le numéro spécifié.

Ref. No.	Part No.	Description	Remark	Ref. No.	Part No.	Description	Remark
251	A-4672-138-A	SLIDER ASSY, COMPLETE		262	4-984-556-01	SHAFT (MAIN SHAFT)	
* 252	4-983-439-01	BRACKET (DAMPER)		* 263	1-661-774-11	SW BOARD	
253	3-953-235-01	DAMPER, OIL		264	A-3304-200-A	SCREW ASSY, LEAD	
254	4-979-901-21	LEVER (LIMITER)		265	4-963-914-02	RACK (INSERTER)	
255	3-342-375-11	SCREW (M1.7X1.4), SPECIAL		266	3-366-890-11	SCREW (M1.4)	
* 256	4-979-890-11	RETAINER (GEAR)		\triangle 267	8-583-028-01	OPTICAL PICK UP BLOCK KMS-260A/J1N	
257	4-979-898-01	GEAR (LB)		268	4-987-061-01	SPACER (RACK)	
258	4-979-899-01	GEAR (LC)		* 269	4-983-437-01	SLIDER (CAM)	
259	4-979-897-01	GEAR (LA)		HR901	1-500-396-11	HEAD, OVER WRITE	
260	4-979-885-01	LEVER (HEAD UP)		M901	A-4672-135-A	MOTOR ASSY, SPINDLE	
261	4-979-906-01	SPRING (LEAD SCREW)		M902	A-4672-133-A	MOTOR ASSY, SLED	
				M903	A-4672-134-A	MOTOR ASSY, LOADING	

SECTION 7 ELECTRICAL PARTS LIST

NOTE:

The components identified by mark Δ or dotted line with mark Δ are critical for safety. Replace only with part number specified.

Les composants identifiés par une marque Δ sont critiques pour la sécurité. Ne les remplacer que par une pièce portant le numéro spécifié.

When indicating parts by reference number, please include the board name.

- Due to standardization, replacements in the parts list may be different from the parts specified in the diagrams or the components used on the set.
- Items marked "*" are not stocked since they are seldom required for routine service. Some delay should be anticipated when ordering these items.
- RESISTORS
All resistors are in ohms
METAL: Metal-film resistor
METAL OXIDE: Metal Oxide-film resistor
F: nonflammable

- SEMICONDUCTORS
In each case, u: μ , for example:
uA...: μ A..., uPA...: μ PA..., uPB...: μ PB...,
uPC...: μ PC..., uPD...: μ PD...
- CAPACITORS
uF: μ F
- COILS
uH: μ H
- Abbreviation
CND : Canadian model
G : German model
HK : Hong Kong model
SP : Singapore model
JE : Tourist model

Ref. No.	Part No.	Description	Remark	Ref. No.	Part No.	Description	Remark
*	A-4699-092-A	BD BOARD, COMPLETE *****		C152	1-163-038-91	CERAMIC CHIP	0.1uF 25V
		< CAPACITOR >		C153	1-164-232-11	CERAMIC CHIP	0.01uF 50V
C101	1-104-851-11	TANTAL. CHIP	10uF 20% 10V	C156	1-163-038-91	CERAMIC CHIP	0.1uF 25V
C102	1-163-038-91	CERAMIC CHIP	0.1uF 25V	C158	1-163-019-00	CERAMIC CHIP	0.0068uF 10% 50V
C103	1-104-851-11	TANTAL. CHIP	10uF 20% 10V	C160	1-104-601-11	ELECT CHIP	10uF 20% 10V
C104	1-104-851-11	TANTAL. CHIP	10uF 20% 10V	C161	1-104-601-11	ELECT CHIP	10uF 20% 10V
C105	1-164-232-11	CERAMIC CHIP	0.01uF 50V	C163	1-164-232-11	CERAMIC CHIP	0.01uF 50V
C106	1-163-275-11	CERAMIC CHIP	0.001uF 5% 50V	C164	1-164-232-11	CERAMIC CHIP	0.01uF 50V
C107	1-163-038-91	CERAMIC CHIP	0.1uF 25V	C167	1-163-038-91	CERAMIC CHIP	0.1uF 25V
C108	1-163-038-91	CERAMIC CHIP	0.1uF 25V	C168	1-163-038-91	CERAMIC CHIP	0.1uF 25V
C109	1-163-037-11	CERAMIC CHIP	0.022uF 10% 25V	C169	1-104-851-11	TANTAL. CHIP	10uF 20% 10V
C110	1-163-038-91	CERAMIC CHIP	0.1uF 25V	C171	1-163-038-91	CERAMIC CHIP	0.1uF 25V
C111	1-164-344-11	CERAMIC CHIP	0.068uF 10% 25V	C181	1-126-206-11	ELECT CHIP	100uF 20% 6.3V
C112	1-163-017-00	CERAMIC CHIP	0.0047uF 5% 50V	C182	1-163-038-91	CERAMIC CHIP	0.1uF 25V
C113	1-107-682-11	CERAMIC CHIP	1uF 10% 16V	C183	1-163-038-91	CERAMIC CHIP	0.1uF 25V
C115	1-164-489-11	CERAMIC CHIP	0.22uF 10% 16V	C184	1-107-836-11	ELECT CHIP	22uF 20% 8V
C116	1-163-037-11	CERAMIC CHIP	0.022uF 10% 25V	C185	1-164-611-11	CERAMIC CHIP	0.001uF 10% 500V
C117	1-164-004-11	CERAMIC CHIP	0.1uF 10% 25V	C187	1-126-206-11	ELECT CHIP	100uF 20% 6.3V
C119	1-104-851-11	TANTAL. CHIP	10uF 20% 10V	C188	1-164-232-11	CERAMIC CHIP	0.01uF 50V
C121	1-126-206-11	ELECT CHIP	100uF 20% 6.3V	C189	1-163-989-11	CERAMIC CHIP	0.033uF 10% 25V
C122	1-164-232-11	CERAMIC CHIP	0.01uF 50V	C190	1-126-206-11	ELECT CHIP	100uF 20% 6.3V
C123	1-163-038-91	CERAMIC CHIP	0.1uF 25V	C191	1-163-038-91	CERAMIC CHIP	0.1uF 25V
C124	1-163-038-91	CERAMIC CHIP	0.1uF 25V	C195	1-164-346-11	CERAMIC CHIP	1uF 16V
C127	1-163-038-91	CERAMIC CHIP	0.1uF 25V	C196	1-163-038-91	CERAMIC CHIP	0.1uF 25V
C128	1-164-232-11	CERAMIC CHIP	0.01uF 50V	C197	1-163-038-91	CERAMIC CHIP	0.1uF 25V
C129	1-107-823-11	CERAMIC CHIP	0.47uF 10% 16V			< CONNECTOR >	
C130	1-163-251-11	CERAMIC CHIP	100PF 5% 50V	CN101	1-766-508-11	CONNECTOR, FFC/FPC (ZIF) 22P	
C131	1-163-023-00	CERAMIC CHIP	0.015uF 5% 50V	CN102	1-778-461-11	CONNECTOR, FFC/FPC 29P	
C132	1-107-823-11	CERAMIC CHIP	0.47uF 10% 16V	CN103	1-778-460-11	CONNECTOR, FFC/FPC 19P	
C133	1-163-017-00	CERAMIC CHIP	0.0047uF 5% 50V	CN104	1-766-898-21	HOUSING, CONNECTOR (PC BOARD) 4P	
C134	1-163-038-91	CERAMIC CHIP	0.1uF 25V	CN106	1-770-698-11	CONNECTOR, FFC/FPC 15P	
C135	1-163-038-91	CERAMIC CHIP	0.1uF 25V	CN110	1-774-731-21	PIN, CONNECTOR (PC BOARD) 5P	
C136	1-126-206-11	ELECT CHIP	100uF 20% 6.3V			< DIODE >	
C141	1-163-038-91	CERAMIC CHIP	0.1uF 25V	D101	8-719-988-62	DIODE 1SS355	
C142	1-163-251-11	CERAMIC CHIP	100PF 5% 50V	D181	8-719-046-86	DIODE F1J6TP	
C143	1-163-251-11	CERAMIC CHIP	100PF 5% 50V	D183	8-719-046-86	DIODE F1J6TP	
C144	1-163-251-11	CERAMIC CHIP	100PF 5% 50V				
C146	1-163-038-91	CERAMIC CHIP	0.1uF 25V				
C151	1-126-206-11	ELECT CHIP	100uF 20% 6.3V				

Ref. No.	Part No.	Description	Remark	Ref. No.	Part No.	Description	Remark
< IC >							
IC101	8-752-074-77	IC CXA2523R		R117	1-216-113-00	METAL CHIP 470K 5%	1/10W
IC103	8-729-903-10	TRANSISTOR FMW1		R120	1-216-025-91	METAL GLAZE 100 5%	1/10W
IC121	8-752-378-54	IC CXD2650R		R121	1-216-097-91	METAL GLAZE 100K 5%	1/10W
IC122	8-759-234-20	IC TC7S08F		R123	1-216-033-00	METAL CHIP 220 5%	1/10W
IC123	8-759-242-70	IC TC7WU04F		R124	1-216-025-91	METAL GLAZE 100 5%	1/10W
IC152	8-759-430-25	IC BH6511FS		R125	1-216-025-91	METAL GLAZE 100 5%	1/10W
IC171	8-759-428-58	IC XL24C01AF		R127	1-216-025-91	METAL GLAZE 100 5%	1/10W
IC181	8-759-095-65	IC TC74ACT540FS		R131	1-216-073-00	METAL CHIP 10K 5%	1/10W
IC192	8-759-426-95	IC L88MS33T-FA-TL		R132	1-216-097-91	METAL GLAZE 100K 5%	1/10W
< COIL >							
L101	1-414-235-11	INDUCTOR, FERRITE BEAD		R133	1-216-117-00	METAL CHIP 680K 5%	1/10W
L102	1-414-235-11	INDUCTOR, FERRITE BEAD		R134	1-216-049-91	METAL GLAZE 1K 5%	1/10W
L103	1-414-235-11	INDUCTOR, FERRITE BEAD		R135	1-216-061-00	METAL CHIP 3.3K 5%	1/10W
L105	1-414-235-11	INDUCTOR, FERRITE BEAD		R136	1-216-049-91	METAL GLAZE 1K 5%	1/10W
L106	1-414-235-11	INDUCTOR, FERRITE BEAD		R137	1-216-025-91	METAL GLAZE 100 5%	1/10W
L121	1-414-235-11	INDUCTOR, FERRITE BEAD		R140	1-216-029-00	METAL CHIP 150 5%	1/10W
L122	1-414-235-11	INDUCTOR, FERRITE BEAD		R141	1-216-295-91	CONDUCTOR, CHIP (2012)	
L151	1-412-622-51	INDUCTOR 10uH		R142	1-216-073-00	METAL CHIP 10K 5%	1/10W
L152	1-412-622-51	INDUCTOR 10uH		R143	1-216-073-00	METAL CHIP 10K 5%	1/10W
L153	1-412-039-51	INDUCTOR CHIP 100uH		R144	1-216-025-91	METAL GLAZE 100 5%	1/10W
L154	1-412-039-51	INDUCTOR CHIP 100uH		R146	1-216-037-00	METAL CHIP 330 5%	1/10W
L161	1-414-235-11	INDUCTOR, FERRITE BEAD		R147	1-216-025-91	METAL GLAZE 100 5%	1/10W
L162	1-414-235-11	INDUCTOR, FERRITE BEAD		R148	1-216-045-00	METAL CHIP 680 5%	1/10W
< TRANSISTOR >							
Q101	8-729-403-35	TRANSISTOR UN5113		R150	1-216-295-91	CONDUCTOR, CHIP (2012)	
Q102	8-729-026-53	TRANSISTOR 2SA1576A-T106-QR		R158	1-216-097-91	METAL GLAZE 100K 5%	1/10W
Q103	8-729-014-04	TRANSISTOR RN1307-TE85L		R159	1-216-097-91	METAL GLAZE 100K 5%	1/10W
Q104	8-729-014-04	TRANSISTOR RN1307-TE85L		R161	1-216-057-00	METAL CHIP 2.2K 5%	1/10W
Q162	8-729-101-07	TRANSISTOR 2SB798-DL		R162	1-216-057-00	METAL CHIP 2.2K 5%	1/10W
Q163	8-729-403-35	TRANSISTOR UN5113		R163	1-216-057-00	METAL CHIP 2.2K 5%	1/10W
Q180	8-729-907-00	TRANSISTOR DTC114EU		R164	1-216-045-00	METAL CHIP 680 5%	1/10W
Q181	8-729-018-75	TRANSISTOR 2SJ278MY		R165	1-216-097-91	METAL GLAZE 100K 5%	1/10W
Q182	8-729-017-65	TRANSISTOR 2SK1764KY		R166	1-220-149-11	METAL GLAZE 2.2 10%	1/2W
< RESISTOR >							
R101	1-216-295-91	CONDUCTOR, CHIP (2012)		R167	1-216-065-00	METAL CHIP 4.7K 5%	1/10W
R103	1-216-049-91	METAL GLAZE 1K 5%	1/10W	R169	1-219-724-11	METAL CHIP 1 1%	1/4W
R104	1-216-073-00	METAL CHIP 10K 5%	1/10W	R170	1-216-073-00	METAL CHIP 10K 5%	1/10W
R105	1-216-065-00	METAL CHIP 4.7K 5%	1/10W	R171	1-216-073-00	METAL CHIP 10K 5%	1/10W
R106	1-216-133-00	METAL CHIP 3.3M 5%	1/10W	R172	1-216-295-91	CONDUCTOR, CHIP (2012)	
R107	1-216-113-00	METAL CHIP 470K 5%	1/10W	R173	1-216-121-91	METAL GLAZE 1M 5%	1/10W
R109	1-216-295-91	CONDUCTOR, CHIP (2012)		R175	1-216-061-00	METAL CHIP 3.3K 5%	1/10W
R110	1-216-073-00	METAL CHIP 10K 5%	1/10W	R176	1-216-295-91	CONDUCTOR, CHIP (2012)	
R111	1-216-295-91	CONDUCTOR, CHIP (2012)		R177	1-216-061-00	METAL CHIP 3.3K 5%	1/10W
R112	1-216-089-91	METAL GLAZE 47K 5%	1/10W	R178	1-216-295-91	CONDUCTOR, CHIP (2012)	
R113	1-216-049-91	METAL GLAZE 1K 5%	1/10W	R179	1-216-089-91	METAL GLAZE 47K 5%	1/10W
R115	1-216-049-91	METAL GLAZE 1K 5%	1/10W	R180	1-216-073-00	METAL CHIP 10K 5%	1/10W
				R181	1-216-073-00	METAL CHIP 10K 5%	1/10W
				R182	1-216-089-91	METAL GLAZE 47K 5%	1/10W
				R183	1-216-089-91	METAL GLAZE 47K 5%	1/10W
				R184	1-216-073-00	METAL CHIP 10K 5%	1/10W
				R185	1-216-073-00	METAL CHIP 10K 5%	1/10W
				R186	1-216-296-91	CONDUCTOR, CHIP (3216)	
				R187	1-216-296-91	CONDUCTOR, CHIP (3216)	

BD

CONTROL SW

DISPLAY

Ref. No.	Part No.	Description	Remark
R188	1-216-073-00	METAL CHIP	10K 5% 1/10W
R189	1-216-073-00	METAL CHIP	10K 5% 1/10W
R190	1-216-073-00	METAL CHIP	10K 5% 1/10W
R195	1-216-295-91	CONDUCTOR, CHIP (2012)	
R196	1-216-295-91	CONDUCTOR, CHIP (2012)	
R198	1-216-295-91	CONDUCTOR, CHIP (2012)	
R199	1-216-295-91	CONDUCTOR, CHIP (2012)	
R200	1-216-295-91	CONDUCTOR, CHIP (2012)	
R201	1-216-295-91	CONDUCTOR, CHIP (2012)	
R202	1-216-295-91	CONDUCTOR, CHIP (2012)	
R502	1-216-295-91	CONDUCTOR, CHIP (2012)	
R504	1-216-295-91	CONDUCTOR, CHIP (2012)	

*	A-4699-142-A	CONTROL SW BOARD, COMPLETE	*****
		< CAPACITOR >	
C709	1-126-153-11	ELECT	22uF 20% 6.3V
		< CONNECTOR >	
CN701	1-778-324-11	CONNECTOR (FFC) 29P	
CN704	1-766-805-11	CONNECTOR, BOARD TO BOARD 3P	
CN706	1-778-317-11	CONNECTOR, BOARD TO BOARD 13P	
		< RESISTOR >	
R706	1-249-417-11	CARBON	1K 5% 1/4W F
R707	1-249-429-11	CARBON	10K 5% 1/4W
R708	1-249-429-11	CARBON	10K 5% 1/4W
R709	1-249-429-11	CARBON	10K 5% 1/4W
R752	1-249-421-11	CARBON	2.2K 5% 1/4W F
R753	1-247-843-11	CARBON	3.3K 5% 1/4W
R754	1-249-425-11	CARBON	4.7K 5% 1/4W F
R755	1-249-429-11	CARBON	10K 5% 1/4W
R756	1-249-435-11	CARBON	33K 5% 1/4W
R762	1-249-421-11	CARBON	2.2K 5% 1/4W F
R763	1-247-843-11	CARBON	3.3K 5% 1/4W
R764	1-249-425-11	CARBON	4.7K 5% 1/4W F
R772	1-249-421-11	CARBON	2.2K 5% 1/4W F
R773	1-247-843-11	CARBON	3.3K 5% 1/4W
R774	1-249-425-11	CARBON	4.7K 5% 1/4W F
R775	1-249-429-11	CARBON	10K 5% 1/4W
R776	1-249-435-11	CARBON	33K 5% 1/4W
R777	1-249-429-11	CARBON	10K 5% 1/4W
		< VARIABLE RESISTOR >	
RV701	1-223-762-11	RES, VAR, CARBON 20K/20K (REC LEVEL)	

Ref. No.	Part No.	Description	Remark
		< SWITCH >	
S701	1-473-779-11	ENCODER, ROTARY (AMS (PUSH ENTER))	
S702	1-572-624-11	SWITCH, SLIDE (INPUT)	
S703	1-572-624-11	SWITCH, SLIDE (REC MODE)	
S751	1-554-303-21	SWITCH, TACTILE (NO/EDIT)	
S752	1-554-303-21	SWITCH, TACTILE (YES)	
S756	1-554-303-21	SWITCH, TACTILE (DISPLAY/CHAR)	
S761	1-554-303-21	SWITCH, TACTILE (PLAY MODE)	
S762	1-554-303-21	SWITCH, TACTILE (REPEAT)	
S763	1-554-303-21	SWITCH, TACTILE (SCROLL)	
S771	1-554-303-21	SWITCH, TACTILE (● REC)	
S772	1-554-303-21	SWITCH, TACTILE (■)	
S774	1-554-303-21	SWITCH, TACTILE (▶▶)	
S775	1-554-303-21	SWITCH, TACTILE (◀◀)	
S780	1-554-303-21	SWITCH, TACTILE (▨)	
S781	1-554-303-21	SWITCH, TACTILE (▷)	

*	A-4699-141-A	DISPLAY BOARD, COMPLETE	*****
		2-389-320-01 CUSHION	
*		4-972-608-01 HOLDER (DIA. 5), LED	
*		4-983-462-01 HOLDER (FL)	
		< CAPACITOR >	
C705	1-162-294-31	CERAMIC	0.001uF 10% 50V
C706	1-162-294-31	CERAMIC	0.001uF 10% 50V
C707	1-162-294-31	CERAMIC	0.001uF 10% 50V
C708	1-162-306-11	CERAMIC	0.01uF 20% 16V
C710	1-162-215-31	CERAMIC	47PF 5% 50V
C717	1-128-057-11	ELECT	330uF 20% 6.3V
C718	1-162-306-11	CERAMIC	0.01uF 20% 16V
C721	1-162-306-11	CERAMIC	0.01uF 20% 16V
		< CONNECTOR >	
CN707	1-778-318-11	CONNECTOR, BOARD TO BOARD 13P	
		< DIODE >	
D701	8-719-313-40	DIODE SEL1516W (POWER)	
		< FLUORESCENT INDICATOR >	
FL701	1-517-575-11	INDICATOR TUBE, FLUORESCENT	
		< IC >	
IC701	8-759-426-98	IC MSM9202-02GS-K	
IC702	8-749-012-71	IC GP1UC7XB	

Ref. No.	Part No.	Description	Remark	Ref. No.	Part No.	Description	Remark
		< TRANSISTOR >					
Q701	8-729-422-57	TRANSISTOR UN4111		R714	1-249-393-11	CARBON 10 5% 1/4W F	
Q702	8-729-900-74	TRANSISTOR DTC143TS				< VARIABLE RESISTOR >	
		< RESISTOR >		RV702	1-225-329-11	RES, VAR (PHONE LEVEL)	
R701	1-249-429-11	CARBON 10K 5% 1/4W		*****			
R702	1-249-429-11	CARBON 10K 5% 1/4W		*	A-4699-146-A	MAIN BOARD, COMPLETE (AEP, G, UK, HK)	
R705	1-247-842-11	CARBON 3K 5% 1/4W				*****	
R711	1-249-399-11	CARBON 33 5% 1/4W F		*	A-4699-147-A	MAIN BOARD, COMPLETE (SP, JE)	
R712	1-249-409-11	CARBON 220 5% 1/4W F				*****	
R721	1-247-807-31	CARBON 100 5% 1/4W		*	A-4699-273-A	MAIN BOARD, COMPLETE (US, CND)	
R722	1-247-807-31	CARBON 100 5% 1/4W				*****	
R723	1-247-807-31	CARBON 100 5% 1/4W					
R724	1-247-807-31	CARBON 100 5% 1/4W					
R741	1-249-401-11	CARBON 47 5% 1/4W F					
R791	1-247-807-31	CARBON 100 5% 1/4W					
		< SWITCH >					
S704	1-572-625-11	SWITCH, SLIDE (TIMER)					
S764	1-554-303-21	SWITCH, TACTILE (POWER)					

*	1-661-893-11	EJECT SW BOARD					

		< CONNECTOR >					
CN705	1-766-806-11	HOUSING, CONNECTOR 3P					
		< SWITCH >					
S776	1-554-303-21	SWITCH, TACTILE (EJECT)					

*	1-661-892-11	HP BOARD					

		< CAPACITOR >					
C702	1-162-294-31	CERAMIC 0.001uF 10% 50V		C101	1-162-290-31	CERAMIC 470PF 10% 50V	
C703	1-162-294-31	CERAMIC 0.001uF 10% 50V		C102	1-128-551-11	ELECT 22uF 20% 25V	
		< CONNECTOR >		C103	1-126-964-11	ELECT 10uF 20% 50V	
* CN703	1-564-337-00	PIN, CONNECTOR 3P		C104	1-137-368-11	FILM 0.0047uF 5% 50V	
		< JACK >		C105	1-137-368-11	FILM 0.0047uF 5% 50V	
J701	1-770-307-11	JACK (LARGE TYPE) (PHONES)		C106	1-162-219-31	CERAMIC 68PF 5% 50V	
		< RESISTOR >		C107	1-162-211-31	CERAMIC 33PF 5% 50V	
R713	1-249-393-11	CARBON 10 5% 1/4W F		C108	1-162-211-31	CERAMIC 33PF 5% 50V	
				C109	1-126-933-11	ELECT 100uF 20% 10V	
				C110	1-137-368-11	FILM 0.0047uF 5% 50V	
				C111	1-137-364-11	FILM 0.001uF 5% 50V	
				C112	1-128-551-11	ELECT 22uF 20% 25V	
				C113	1-162-290-31	CERAMIC 470PF 10% 50V	
				C201	1-162-290-31	CERAMIC 470PF 10% 50V	
				C202	1-128-551-11	ELECT 22uF 20% 25V	
				C203	1-126-964-11	ELECT 10uF 20% 50V	
				C204	1-137-368-11	FILM 0.0047uF 5% 50V	
				C205	1-137-368-11	FILM 0.0047uF 5% 50V	
				C206	1-162-219-31	CERAMIC 68PF 5% 50V	
				C207	1-162-211-31	CERAMIC 33PF 5% 50V	
				C208	1-162-211-31	CERAMIC 33PF 5% 50V	
				C209	1-126-933-11	ELECT 100uF 20% 10V	
				C210	1-137-368-11	FILM 0.0047uF 5% 50V	
				C211	1-137-364-11	FILM 0.001uF 5% 50V	
				C212	1-128-551-11	ELECT 22uF 20% 25V	
				C213	1-162-290-31	CERAMIC 470PF 10% 50V	
				C302	1-126-933-11	ELECT 100uF 20% 10V	
				C303	1-126-923-11	ELECT 220uF 20% 10V	
				C304	1-126-923-11	ELECT 220uF 20% 10V	
				C306	1-162-203-31	CERAMIC 15PF 5% 50V	

MAIN

Ref. No.	Part No.	Description	Remark	Ref. No.	Part No.	Description	Remark
C307	1-162-207-31	CERAMIC	22PF 5% 50V	C376	1-162-306-11	CERAMIC 0.01uF 20% 16V	
C309	1-164-159-11	CERAMIC	0.1uF 50V	C401	1-162-203-31	CERAMIC 15PF 5% 50V	
C310	1-126-933-11	ELECT	100uF 20% 10V	C402	1-162-203-31	CERAMIC 15PF 5% 50V	
C311	1-126-923-11	ELECT	220uF 20% 10V			< CONNECTOR >	
C312	1-164-159-11	CERAMIC	0.1uF 50V				
C313	1-164-159-11	CERAMIC	0.1uF 50V	CN301	1-580-230-11	PIN, CONNECTOR (PC BOARD) 2P	
C314	1-126-923-11	ELECT	220uF 20% 10V	CN303	1-770-657-11	CONNECTOR, FFC/FPC 29P	
C315	1-164-159-11	CERAMIC	0.1uF 50V	CN304	1-770-657-11	CONNECTOR, FFC/FPC 29P	
C316	1-126-923-11	ELECT	220uF 20% 10V	CN305	1-770-167-11	CONNECTOR, FFC/FPC 19P	
C317	1-164-159-11	CERAMIC	0.1uF 50V			< DIODE >	
C318	1-126-923-11	ELECT	220uF 20% 10V	D301	8-719-987-63	DIODE 1N4148M	
C319	1-126-923-11	ELECT	220uF 20% 10V	D302	8-719-987-63	DIODE 1N4148M	
C320	1-126-933-11	ELECT	100uF 20% 16V	D303	8-719-200-82	DIODE 11ES2	
C321	1-126-933-11	ELECT	100uF 20% 16V	D304	8-719-200-82	DIODE 11ES2	
C322	1-115-364-11	ELECT	22000uF 20% 16V	D305	8-719-200-82	DIODE 11ES2	
C323	1-126-937-11	ELECT	4700uF 20% 16V	D306	8-719-200-82	DIODE 11ES2	
C324	1-126-964-11	ELECT	10uF 20% 50V	D307	8-719-200-82	DIODE 11ES2	
C325	1-131-349-00	TANTAL.	2.2uF 10% 35V	D308	8-719-109-89	DIODE RD5.6ESB2	
C326	1-126-963-11	ELECT	4.7uF 20% 50V	D311	8-719-987-63	DIODE 1N4148M	
C327	1-126-916-11	ELECT	1000uF 20% 6.3V	D315	8-719-987-63	DIODE 1N4148M	
C328	1-126-933-11	ELECT	100uF 20% 10V			< GROUND PLATE >	
△C329	1-113-920-11	CERAMIC	0.0022uF 20% 250V	* EP301	4-962-200-01	PLATE (TR), GROUND	
△C330	1-113-925-11	CERAMIC	0.01uF 20% 250V (AEP, G, UK, HK)			< IC >	
△C331	1-113-920-11	CERAMIC	0.0022uF 20% 250V	IC301	8-759-434-43	IC CXA8065S	
C332	1-128-576-11	ELECT	100uF 20% 63V	IC303	8-759-708-06	IC NJM78L06A	
C333	1-126-950-11	ELECT	330uF 20% 35V	IC304	8-759-700-69	IC NJM79L12A	
C334	1-164-159-11	CERAMIC	0.1uF 50V	IC307	8-759-426-99	IC CXD8607N	
C336	1-162-306-11	CERAMIC	0.01uF 20% 16V	IC308	8-759-634-50	IC M5218AL	
C340	1-164-159-11	CERAMIC	0.1uF 50V	IC309	8-759-426-96	IC LA5620	
C341	1-164-159-11	CERAMIC	0.1uF 50V	IC310	8-759-633-42	IC M5293L	
C342	1-164-159-11	CERAMIC	0.1uF 50V	IC311	8-759-822-09	IC LB1641	
C343	1-162-306-11	CERAMIC	0.01uF 20% 16V	IC312	8-749-012-69	IC GP1F38T (DIGITAL OUT)	
C346	1-162-282-31	CERAMIC	100PF 10% 50V	IC313	8-749-012-70	IC GP1F38R (DIGITAL IN)	
C350	1-164-159-11	CERAMIC	0.1uF 50V	IC314	8-759-917-18	IC SN74HCU04AN	
C352	1-162-294-31	CERAMIC	0.001uF 10% 50V	IC316	8-759-427-01	IC RU8X11AMF-0101	
C353	1-164-159-11	CERAMIC	0.1uF 50V			< JACK >	
C354	1-164-159-11	CERAMIC	0.1uF 50V	J301	1-770-720-11	JACK, PIN 4P (LINE (ANALOG) IN/OUT)	
C355	1-162-282-31	CERAMIC	100PF 10% 50V			< COIL >	
C356	1-162-282-31	CERAMIC	100PF 10% 50V	L305	1-410-328-21	INDUCTOR 10uH	
C357	1-164-159-11	CERAMIC	0.1uF 50V			< LINE FILTER >	
C358	1-164-159-11	CERAMIC	0.1uF 50V	△LF301	1-424-485-11	FILTER, LINE	
C359	1-162-282-31	CERAMIC	100PF 10% 50V				
C360	1-162-282-31	CERAMIC	100PF 10% 50V				
C361	1-164-159-11	CERAMIC	0.1uF 50V				
C365	1-128-551-11	ELECT	22uF 20% 25V				
C370	1-124-902-00	ELECT	0.47uF 20% 50V				
C372	1-164-159-11	CERAMIC	0.1uF 50V				
C373	1-162-306-11	CERAMIC	0.01uF 20% 16V				
C374	1-162-306-11	CERAMIC	0.01uF 20% 16V				
C375	1-162-306-11	CERAMIC	0.01uF 20% 16V				

The components identified by mark △ or dotted line with mark △ are critical for safety. Replace only with part number specified.	Les composants identifiés par une marque △ sont critiques pour la sécurité. Ne les remplacer que par une pièce portant le numéro spécifié.
--	--

Ref. No.	Part No.	Description	Remark	Ref. No.	Part No.	Description	Remark
< TRANSISTOR >				R219	1-249-411-11	CARBON	330 5% 1/4W
Q101	8-729-900-74	TRANSISTOR DTC143TS		R220	1-249-415-11	CARBON	680 5% 1/4W F
Q102	8-729-900-74	TRANSISTOR DTC143TS		R301	1-247-903-00	CARBON	1M 5% 1/4W
Q301	8-729-119-76	TRANSISTOR 2SA1175-HFE		R302	1-249-411-11	CARBON	330 5% 1/4W
Q302	8-729-900-80	TRANSISTOR DTC114ES		R305	1-249-429-11	CARBON	10K 5% 1/4W
Q306	8-729-422-57	TRANSISTOR UN4111		R306	1-249-429-11	CARBON	10K 5% 1/4W
Q307	8-729-900-80	TRANSISTOR DTC114ES		R307	1-249-401-11	CARBON	47 5% 1/4W F
Q308	8-729-422-61	TRANSISTOR UN4115		R308	1-249-401-11	CARBON	47 5% 1/4W F
< RESISTOR >				R309	1-249-413-11	CARBON	470 5% 1/4W F
R100	1-249-429-11	CARBON	10K 5% 1/4W	R310	1-249-409-11	CARBON	220 5% 1/4W F
R101	1-249-437-11	CARBON	47K 5% 1/4W	R311	1-249-409-11	CARBON	220 5% 1/4W F
R102	1-247-887-00	CARBON	220K 5% 1/4W	R312	1-247-807-31	CARBON	100 5% 1/4W
R103	1-249-433-11	CARBON	22K 5% 1/4W	R313	1-249-417-11	CARBON	1K 5% 1/4W F
R104	1-247-874-11	CARBON	62K 5% 1/4W	R314	1-249-429-11	CARBON	10K 5% 1/4W
R105	1-249-429-11	CARBON	10K 5% 1/4W F	R315	1-249-437-11	CARBON	47K 5% 1/4W
R106	1-249-429-11	CARBON	10K 5% 1/4W F	R316	1-249-403-11	CARBON	68 5% 1/4W F
R107	1-249-401-11	CARBON	47 5% 1/4W F	R318	1-249-429-11	CARBON	10K 5% 1/4W
R108	1-249-401-11	CARBON	47 5% 1/4W F	R319	1-249-429-11	CARBON	10K 5% 1/4W
R109	1-249-435-11	CARBON	33K 5% 1/4W	R320	1-249-429-11	CARBON	10K 5% 1/4W
R110	1-249-435-11	CARBON	33K 5% 1/4W	R321	1-249-429-11	CARBON	10K 5% 1/4W
R111	1-249-433-11	CARBON	22K 5% 1/4W	R326	1-247-895-00	CARBON	470K 5% 1/4W
R112	1-249-433-11	CARBON	22K 5% 1/4W	R327	1-249-437-11	CARBON	47K 5% 1/4W
R113	1-249-439-11	CARBON	68K 5% 1/4W	R328	1-249-429-11	CARBON	10K 5% 1/4W
R114	1-249-439-11	CARBON	68K 5% 1/4W	R329	1-249-429-11	CARBON	10K 5% 1/4W
R115	1-249-429-11	CARBON	10K 5% 1/4W	R330	1-249-429-11	CARBON	10K 5% 1/4W
R116	1-249-421-11	CARBON	2. 2K 5% 1/4W F	R331	1-249-429-11	CARBON	10K 5% 1/4W
R117	1-249-417-11	CARBON	1K 5% 1/4W F	R332	1-249-429-11	CARBON	10K 5% 1/4W
R118	1-249-441-11	CARBON	100K 5% 1/4W	R333	1-249-429-11	CARBON	10K 5% 1/4W
R119	1-249-411-11	CARBON	330 5% 1/4W	R345	1-247-895-00	CARBON	470K 5% 1/4W
R120	1-249-415-11	CARBON	680 5% 1/4W F	R346	1-247-883-00	CARBON	150K 5% 1/4W
R200	1-249-429-11	CARBON	10K 5% 1/4W	R347	1-249-441-11	CARBON	100K 5% 1/4W
R201	1-249-437-11	CARBON	47K 5% 1/4W	R354	1-247-807-31	CARBON	100 5% 1/4W
R202	1-247-887-00	CARBON	220K 5% 1/4W	R358	1-247-903-00	CARBON	1M 5% 1/4W
R203	1-249-433-11	CARBON	22K 5% 1/4W	R361	1-249-429-11	CARBON	10K 5% 1/4W
R204	1-247-874-11	CARBON	62K 5% 1/4W	R362	1-249-441-11	CARBON	100K 5% 1/4W
R205	1-249-429-11	CARBON	10K 5% 1/4W F	R363	1-249-441-11	CARBON	100K 5% 1/4W
R206	1-249-429-11	CARBON	10K 5% 1/4W F	R366	1-249-441-11	CARBON	100K 5% 1/4W
R207	1-249-401-11	CARBON	47 5% 1/4W F	R367	1-249-441-11	CARBON	100K 5% 1/4W
R208	1-249-401-11	CARBON	47 5% 1/4W F	R371	1-249-441-11	CARBON	100K 5% 1/4W
R209	1-249-435-11	CARBON	33K 5% 1/4W	R383	1-249-429-11	CARBON	10K 5% 1/4W
R210	1-249-435-11	CARBON	33K 5% 1/4W	R384	1-249-429-11	CARBON	10K 5% 1/4W
R211	1-249-433-11	CARBON	22K 5% 1/4W	R385	1-249-429-11	CARBON	10K 5% 1/4W
R212	1-249-433-11	CARBON	22K 5% 1/4W	R388	1-249-441-11	CARBON	100K 5% 1/4W
R213	1-249-439-11	CARBON	68K 5% 1/4W	R390	1-249-441-11	CARBON	100K 5% 1/4W
R214	1-249-439-11	CARBON	68K 5% 1/4W	R391	1-249-429-11	CARBON	10K 5% 1/4W
R215	1-249-429-11	CARBON	10K 5% 1/4W	R392	1-249-441-11	CARBON	100K 5% 1/4W
R216	1-249-421-11	CARBON	2. 2K 5% 1/4W F	R393	1-249-429-11	CARBON	10K 5% 1/4W
R217	1-249-417-11	CARBON	1K 5% 1/4W F	R395	1-249-429-11	CARBON	10K 5% 1/4W
R218	1-249-441-11	CARBON	100K 5% 1/4W	R399	1-249-429-11	CARBON	10K 5% 1/4W
				R400	1-249-429-11	CARBON	10K 5% 1/4W

MAIN SW

Ref. No.	Part No.	Description	Remark
R401	1-249-429-11	CARBON 10K 5% 1/4W	
R402	1-249-401-11	CARBON 47 5% 1/4W F	
R403	1-249-401-11	CARBON 47 5% 1/4W F	
R405	1-249-429-11	CARBON 10K 5% 1/4W	
< SWITCH >			
△S301	1-572-675-11	SWITCH, POWER VOLTAGE CHANGE (VOLTAGE SELECTOR) (SP, JE)	
△S301	1-762-764-11	SELECTOR, VOLTAGE (MAIN POWER) (AEP, UK, G, HK)	
< VIBRATOR >			
X301	1-579-314-11	VIBRATOR, CRYSTAL (22MHz)	
X302	1-767-157-21	VIBRATOR, CERAMIC (12MHz)	
X303	1-567-098-61	VIBRATOR, CRYSTAL (32.768kHz)	

*	1-661-774-11	SW BOARD	

< CONNECTOR >			
CN601	1-770-698-11	CONNECTOR, FFC/FPC 15P	
CN602	1-778-638-21	PIN, CONNECTOR 2P	
CN603	1-778-638-21	PIN, CONNECTOR 2P	
< SWITCH >			
S681	1-572-467-61	SWITCH, PUSH (1 KEY) (LIMIT IN)	
S682	1-692-377-31	SWITCH, PUSH (1 KEY) (REFLECT)	
S683	1-692-847-21	SWITCH, PUSH (1 KEY) (PROTECT)	
S685	1-572-467-41	SWITCH, PUSH (1 KEY) (CHUCKING IN)	
S686	1-762-621-21	SWITCH, PUSH (1 KEY) (PACK OUT)	
S687	1-572-688-11	SWITCH, PUSH (1 KEY) (PB POSITION)	
S688	1-762-621-21	SWITCH, PUSH (1 KEY) (REC POSITION)	

MISCELLANEOUS			

3	1-777-278-11	WIRE (FLAT TYPE) (19 CORE)	
6	1-777-275-11	WIRE (FLAT TYPE) (29 CORE)	
7	1-777-276-11	WIRE (FLAT TYPE) (29 CORE)	
△12	1-558-945-21	CORD, POWER (POLAR, SPT-1) (US, CND)	
△12	1-696-027-11	CORD, POWER (JE)	
△12	1-696-586-21	CORD, POWER (UK)	
△12	1-751-275-11	CORD, POWER (AEP, G, SP, HK)	
△14	1-569-007-11	ADAPTOR, CONVERSION 2P (JE)	
△14	1-569-008-11	ADAPTOR, CONVERSION 2P (SP)	
△14	1-770-019-11	ADAPTOR, CONVERSION PLUG 3P (HK)	
206	1-660-966-11	OP RELAY FLEXIBLE BOARD	
208	1-777-517-11	WIRE (FLAT TYPE) (15 CORE)	
△267	8-583-028-01	OPTICAL PICK UP BLOCK KMS-260A/J1N	

Ref. No.	Part No.	Description	Remark
* EP301	4-962-200-01	PLATE (TR), GROUND	
FL701	1-517-575-11	INDICATOR TUBE, FLUORESCENT	
HR901	1-500-396-11	HEAD, OVER WRITE	
M901	A-4672-135-A	MOTOR ASSY, SPINDLE	
M902	A-4672-133-A	MOTOR ASSY, SLED	
M903	A-4672-134-A	MOTOR ASSY, LOADING	
△TR301	1-429-735-11	TRANSFORMER, POWER (US, CND)	
△TR301	1-429-736-11	TRANSFORMER, POWER (AEP, G, UK, HK)	
△TR301	1-429-737-11	TRANSFORMER, POWER (SP, JE)	

ACCESSORIES & PACKING MATERIALS

- 1-473-785-11 REMOTE COMMANDER (RM-D7M)
- 1-558-271-11 CORD, CONNECTION (AUDIO 108CM)
- 1-574-264-11 CORD, LIGHT PLUG (EXCEPT US)
- 3-856-651-11 MANUAL, INSTRUCTION (ENGLISH, FRENCH, SPANISH, PORTUGUESE) (EXCEPT US)
- 3-856-651-21 MANUAL, INSTRUCTION (ENGLISH) (US)
- 3-856-651-31 MANUAL, INSTRUCTION (CHINESE) (SP, HK, JE)
- 3-856-651-41 MANUAL, INSTRUCTION (GERMAN, DUTCH, SWEDISH, ITALIAN) (AEP, G)
- 4-983-537-01 COVER, BATTERY (for RM-D7M)

HARDWARE LIST

- #1 7-685-871-01 SCREW +BVIT 3X6 (S)
- #2 7-685-872-09 SCREW +BVIT 3X8 (S)
- #3 7-685-646-79 SCREW +BVTP 3X8 TYPE 2 N-S
- #4 7-621-255-10 SCREW +BVIT 2X3 (S)
- #5 7-627-553-17 PRECISION SCREW +P 2X2 TYPE 3
- #6 7-627-852-68 SCREW, PRECISION +P 1.7X6 TYPE 3
- #7 7-621-255-45 SCREW +PTT 2X6 (S)
- #8 7-627-552-08 SCREW, PRECISION +P 1.7X2.5

The components identified by mark △ or dotted line with mark △ are critical for safety. Replace only with part number specified.	Les composants identifiés par une marque △ sont critiques pour la sécurité. Ne les remplacer que par une pièce portant le numéro spécifié.
--	--

MDS-JE500

SONY

SERVICE MANUAL

1997.04

*US Model
Canadian Model
AEP Model
UK Model
E Model
Tourist Model*

SUPPLEMENT-1

File this supplement with the service manual.

- Subject :**
- 1. CORRECTION**
 - 2. PARTS CHANGED AND PARTS ADDITION**
 - 3. SERVICING NOTE**
 - 4. ADDITION OF COUNTERMEASURE (DUS) BOARD AND BOARD CHANGED**
 - 5. ADDITION OF MALAYSIA PRODUCT MODEL**

(ECN-CD600791)

1. CORRECTION

- Correct your service manual as shown below.

 : Indicates corrected portion

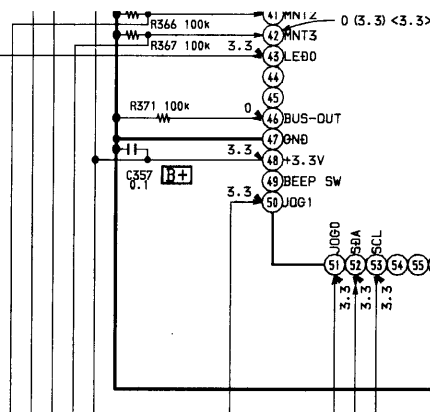
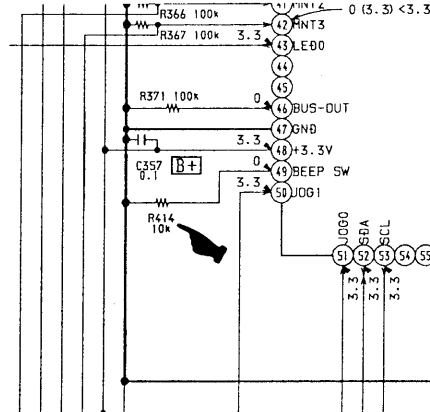
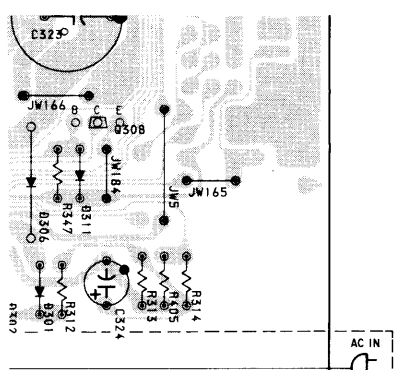
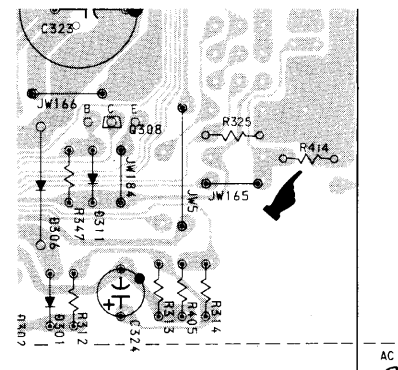
Page	INCORRECT	CORRECT
20	<p>2-5. SHUTTER ASSEMBLY</p> <p>When installing, install the shaft (shutter) A into the hole as shown in the figure before installing the shaft (shutter) B into the hole B.</p>	<p>2-5. SHUTTER ASSEMBLY</p> <p>When installing, install the shaft (shutter) A into the <u>hole A</u> as shown in the figure before installing the shaft (shutter) B into the <u>hole B</u>.</p>
43	<p>[MAIN BOARD] Location : J-K, 2-4</p> 	<p>[MAIN BOARD] Location : J-K, 2-4</p> 
48	<p>[MAIN BOARD] Location : E-G, 12-13</p> 	<p>[MAIN BOARD] Location : E-G, 12-13</p> 

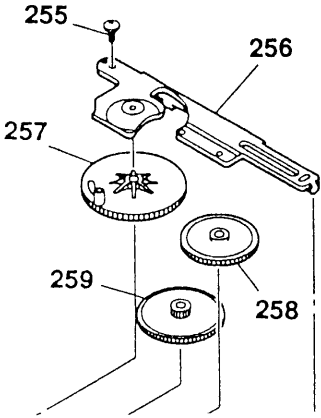
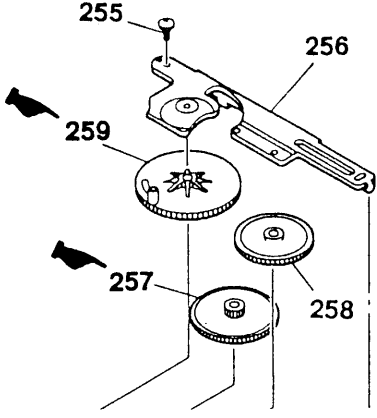
Page	INCORRECT				CORRECT			
	Ref. No.	Part No.	Description	Remark	Ref. No.	Part No.	Description	Remark
69			 <p>*** EXPLODED VIEWS ***</p>				 <p>*** EXPLODED VIEWS ***</p>	
	261	4-979-906-01	SPRING (LEAD SCREW)		261	4-979-906-11	SPRING (LEAD SCREW)	
76	<p>*** ELECTRICAL PARTS LIST ***</p> <p>*** MAIN BOARD ***</p> <hr/>				<p>*** ELECTRICAL PARTS LIST ***</p> <p>*** MAIN BOARD ***</p>			
	R414	1-249-429-11	CARBON	10K	5%	1/4W		

2. PARTS CHANGED AND PARTS ADDITION

 : Indicates changed portion.

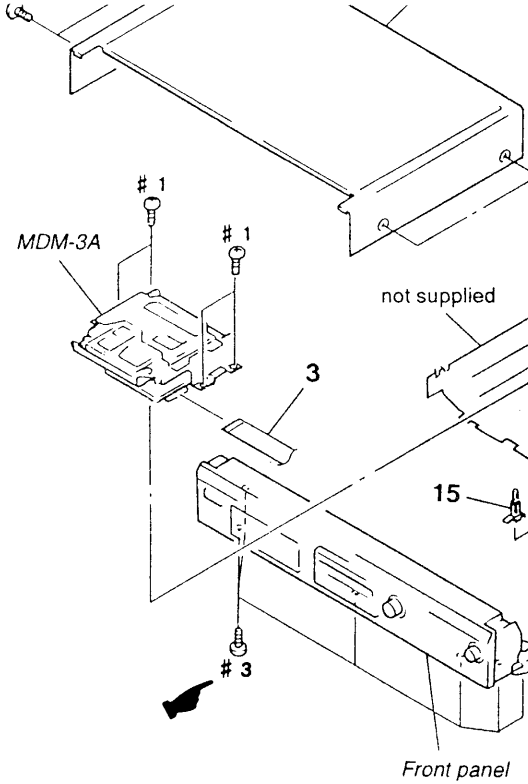
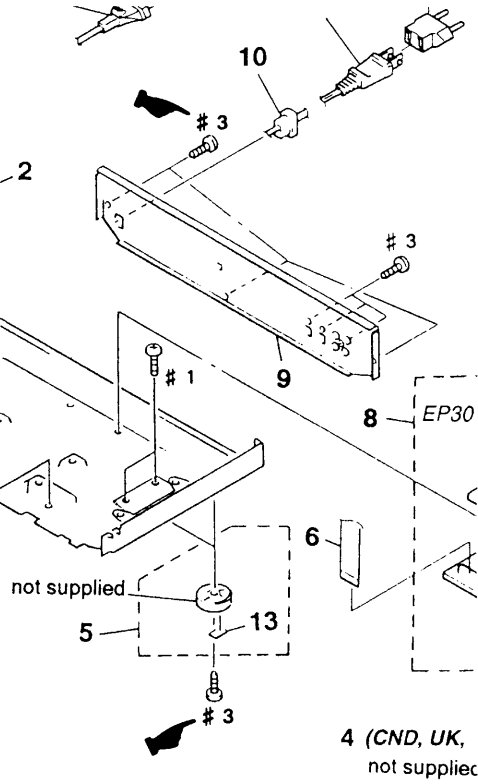
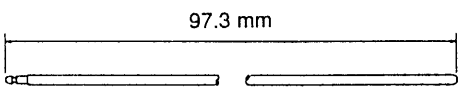
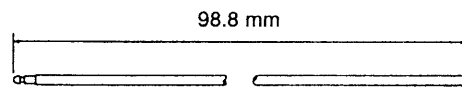
Page	FORMER				NEW			
	Ref. No.	Part No.	Description	Remark	Ref. No.	Part No.	Description	Remark
			*** EXPLODED VIEWS ***				*** EXPLODED VIEWS ***	
67	* 60	A-4699-141-A	DISPLAY BOARD, COMPLETE		* 60	A-4699-141-A	DISPLAY BOARD, COMPLETE (SP, JE)	
			_____		* 60	A-4699-524-A	DISPLAY BOARD, COMPLETE (AEP, G, UK, HK)	
	* 64	A-4699-142-A	CONTROL SW BOARD, COMPLETE		* 60	A-4699-527-A	DISPLAY BOARD, COMPLETE (US, CND)	
			_____		* 64	A-4699-142-A	CONTROL SW BOARD, COMPLETE (SP,JE)	
			_____		* 64	A-4699-525-A	CONTROL SW BOARD, COMPLETE (AEP, G, UK, HK)	
					* 64	A-4699-528-A	CONTROL SW BOARD, COMPLETE (US, CND)	
								
68	204	4-979-904-01	SHAFT (SHUTTER) (A)		204	4-987-736-01	SHAFT (SHUTTER)	
								

• Abbreviation

- CND : Canadian model
- G : German model
- HK : Hong Kong model
- SP : Singapore model
- JE : Tourist model

 : Indicates changed portion.

Page	FORMER				NEW			
	Ref. No.	Part No.	Description	Remark	Ref. No.	Part No.	Description	Remark
69					269	4-988-560-01	SCREW (+P 1.7x6)	
					270	4-955-841-11	SCREW	

Page	FORMER				NEW			
	Ref. No.	Part No.	Description	Remark	Ref. No.	Part No.	Description	Remark
73	*** ELECTRICAL PARTS LIST ***				*** ELECTRICAL PARTS LIST ***			
	*** HP BOARD ***				*** HP BOARD ***			
	J701	1-770-307-11	JACK (LARGE TYPE) (PHONES)		J701	1-770-306-11	JACK (LARGE TYPE) (PHONES)	
76	*** HARDWARE LIST ***				*** HARDWARE LIST ***			
	#2	7-685-872-09	SCREW +BVTT 3x8 (S)				NOT USED	
	#4	7-621-255-10	SCREW +BVTT 2x3 (S)		#4	7-685-850-04	SCREW +BVTP 3x8 TYPE2 TT(B)	
	#6	7-627-852-68	SCREW, PRECISION +P 1.7x6 TYPE 3		#6	7-627-852-28	+P1.7x3	
	#7	7-621-255-45	SCREW, +PTT 2x6 (S)		#7	7-685-851-04	SCREW +BVTT 2x4 (S)	
	#8	7-627-552-08	SCREW, PRECISION +P 1.7x2.5		#8	7-627-552-27	SCREW, PRECISION +P 1.7x2	

3. SERVICING NOTE

JIG FOR CHECKING BD BOARD WAVEFORM

The special jig (J-2501-124-A) is useful for checking the waveform of the BD board. The names of terminals and the checking items to be performed are shown as follows.

- I+3V : For measuring IOP (Check the deterioration of the optical pick-up laser)
- IOP : For measuring IOP (Check the deterioration of the optical pick-up laser)
- TEO : TRK error signal (Traverse adjustment)
- VC : Reference level for checking the signal
- RF : RF signal (Check jitter)

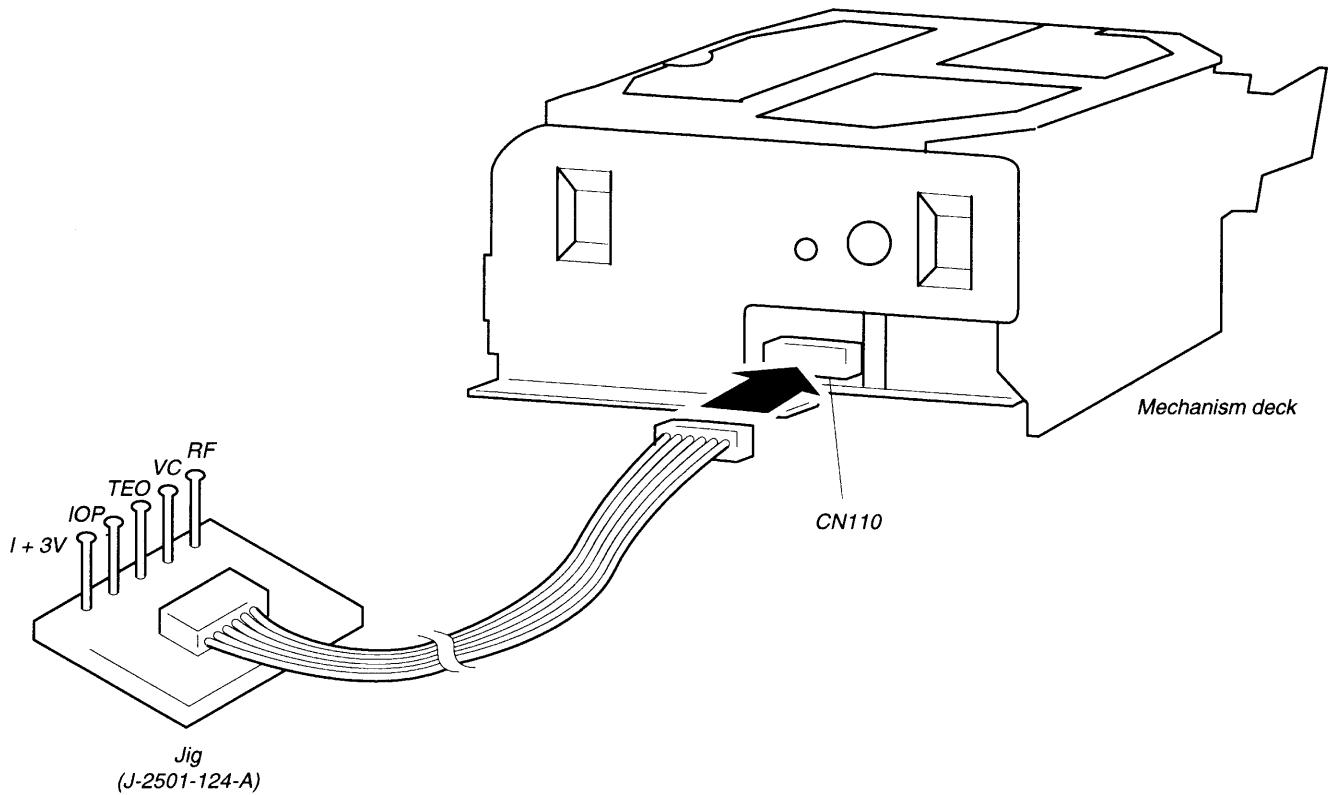

RETRY CAUSE DISPLAY MODE

- In this test mode, the causes for retry of the unit during recording can be displayed on the fluorescent display tube. This is useful for locating the faulty part of the unit.
- The data amount stored in D RAM, number of retries, and retry cause are displayed. Each is displayed in hexadecimal number.
- The display of the D RAM data amount enables data reading, accumulation, ejection, and writing to be performed smoothly. If writing is not smooth, data may decrease considerably.

Method:

1. Load a recordable disc whose contents can be erased into the unit.
2. Press the EDIT/NO button several times to display "All Erase?" on the fluorescent display tube.
3. Press the YES button.
4. When "All Erase??" is displayed on the fluorescent display tube, the numbers on the music calendar will start blinking.
5. Press the YES button to display "Complete", and press the ■ button immediately and continue pressing for about 10 seconds.
6. When the "TOC" displayed on the fluorescent display tube goes off, release the ■ button.
7. Press the ● REC button to start recording.
8. Press the DISPLAY button to display the test mode (Fig. 1), and check the display.
9. The Rt value increases with each retry. If an error occurs after a retry, "Retry Error" will be displayed, and the number of retries counted will be set back to 0.
10. To exit the test mode, press the POWER button. Turn OFF the power, and after "TOC" disappears, disconnect the power plug from the outlet.

Fig. 1 Reading the Test Mode Display

SC @@ Rt ## **

Fluorescent Display Tube Signs

- @@ : Displays the DRAM memory amount when at all times.
: Displays the number of retries. When a retry error occurs, the number will be set back to 0.
** : Cause of retry

All three displays above are in hexadecimal numbers.

Reading the Retry Cause Display

Hexadecimal	Higher Bits				Lower Bits				Hexa-decimal	Cause of Retry	Occurring conditions
	8	4	2	1	8	4	2	1			
Bit	b7	b6	b5	b4	b3	b2	b1	b0			
Binary	0	0	0	0	0	0	0	0	00	Spindle is slow	When spindle rotation is detected as slow
	0	0	0	0	0	0	0	1	01	(Not used)	(Not used)
	0	0	0	0	0	0	1	0	02	ader5	When ADER was counted more than five times continuously
	0	0	0	0	0	1	0	0	04	Discontinuous address	When ADIP address is not continuous
	0	0	0	0	1	0	0	0	08	(Not used)	(Not used)
	0	0	0	1	0	0	0	0	10	FCS incorrect	When not in focus
	0	0	1	0	0	0	0	0	20	IVR rec error	When ABCD signal level exceeds the specified range
	0	1	0	0	0	0	0	0	40	CLV unlock	When CLV is unlocked
	1	0	0	0	0	0	0	0	80	Access fault	When access operation is not performed normally

Reading the Display:

Convert the hexadecimal display into binary display. If more than two causes, they will be added.

Example

When 42 is displayed:

Higher bit : 4 = 0100 → b6

Lower bit : 2 = 0010 → b1

In this case, the retry cause is combined of "CLV unlock" and "ader5".

When A2 is displayed:

Higher bit : A = 1010 → b7+b5

Lower bit : 2 = 0010 → b1

The retry cause in this case is combined of "access fault", "IVR rec error", and "ader5".

Hexadecimal → Binary Conversion Table

Hexadecimal	Binary	Hexadecimal	Binary
0	0000	8	1000
1	0001	9	1001
2	0010	A	1010
3	0011	B	1011
4	0100	C	1100
5	0101	D	1101
6	0110	E	1110
7	0111	F	1111

4. ADDITION OF COUNTERMEASURE (DUS) BOARD AND BOARD CHANGES

[Addition of Countermeasure (DUS) Board]

This unit was added with a countermeasure (DUS) board during production. This DUS board is not supplied as a service part.

Electrical Parts List of DUS Board

Ref. No.	Part No.	Description
	not supplied	*** COUNTERMEASURE (DUS) BOARD ***
C1	1-126-963-11	ELECT 4.7uF 20% 50V
C2	1-163-038-00	CERAMIC CHIP 0.1uF 25V
C3	1-163-038-00	CERAMIC CHIP 0.1uF 25V
C4	1-137-399-11	FILM 0.1uF 100V
C5	1-163-038-00	CERAMIC CHIP 0.1uF 25V
C6	1-137-426-11	CERAMIC 0.47uF 10% 100V
C7	1-137-009-11	CERAMIC CHIP 0.001uF 10% 50V
C8	1-167-416-11	FILM 0.01uF 10% 100V
C9	1-137-416-11	FILM 0.01uF 10% 100V
C10	1-137-009-11	CERAMIC CHIP 0.001uF 10% 50V
CN1	not supplied	CONNECTOR, BOARD IN 8P
D1	8-719-016-74	DIODE 1SS352
D2	8-719-016-74	DIODE 1SS352
D3	8-719-016-74	DIODE 1SS352
IC1	8-759-267-86	IC SN74HC00ANS-E20
IC2	8-759-925-80	IC SN74HC14ANS
IC3	8-759-239-55	IC TC74HC123AF
JW1	1-126-295-91	CONDUCTOR, CHIP (2012)
JW2	1-126-295-91	CONDUCTOR, CHIP (2012)
JW3	1-126-295-91	CONDUCTOR, CHIP (2012)
JW4	1-126-295-91	CONDUCTOR, CHIP (2012)
JW5	1-126-295-91	CONDUCTOR, CHIP (2012)
JW6	1-126-295-91	CONDUCTOR, CHIP (2012)
JW7	1-126-295-91	CONDUCTOR, CHIP (2012)
JW9	1-126-295-91	CONDUCTOR, CHIP (2012)
R1	1-216-049-91	METAL GLAZE 1K 5% 1/10W
R2	1-216-113-00	METAL CHIP 470K 5% 1/10W
R3	1-216-097-91	METAL GLAZE 100K 5% 1/10W
R4	1-216-073-00	METAL CHIP 10K 5% 1/10W
R5	1-216-081-00	METAL CHIP 22K 5% 1/10W
R6	1-216-073-00	METAL CHIP 10K 5% 1/10W

Refer to page 13 for the schematic diagram and printed wiring board of the countermeasure (DUS) board.

The countermeasure (DUS) board is not used for some versions of the system control microprocessor (IC316, main board). Order the new type (RU8X11AMF-0109 (8-759-451-86) when replacing IC316 of main board.

MAIN board IC316 (System control microprocessor)		CONTERMEASURE (DUS) board
Former type	RU8X11AMF-0101	Used
New type	RU8X11AMF-0106	Not used
	RU8X11AMF-0109	
	wards	

How to discriminate

main board IC316

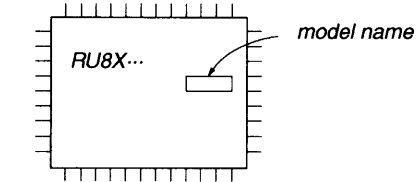

Note 1:

The countermeasure (DUS) board is not used when replacing with the new type of microprocessor (RU8X11AMF-0109 onwards). However, do not attempt to remove it unnecessarily as the unit will operate normally even if it is mounted.

Some set has the countermeasure (DUS) board with using a new type of microprocessor (RU8X11AMF-0106), but no problem for the performance.

Note 2:

If the countermeasure (DUS) board damages, and does not function, perform the following.

Method:

1. Disconnect the countermeasure (DUS) board from the respective wires.
2. Connect the jumper wire to JW95. ()
3. Replace the system control microprocessor (IC316, main board) with the new type.

[MAIN BOARD] Location : B-C, 1-2

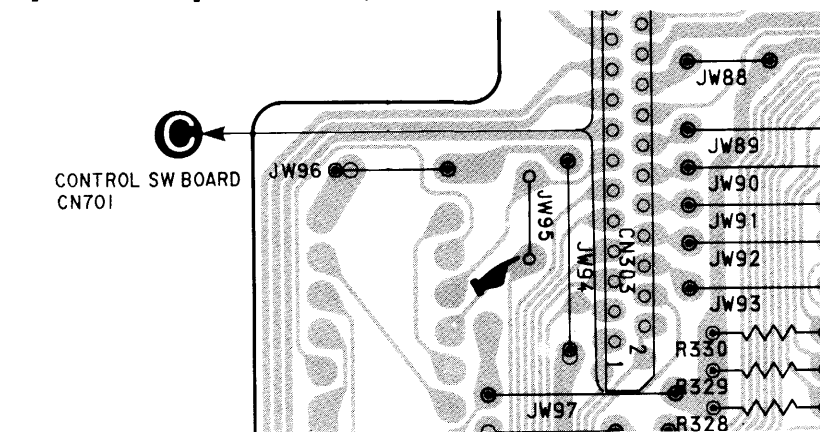

[BOARD CHANGED] PRINTED WIRING BOARD — MAIN SECTION —

Indicates changed portion.

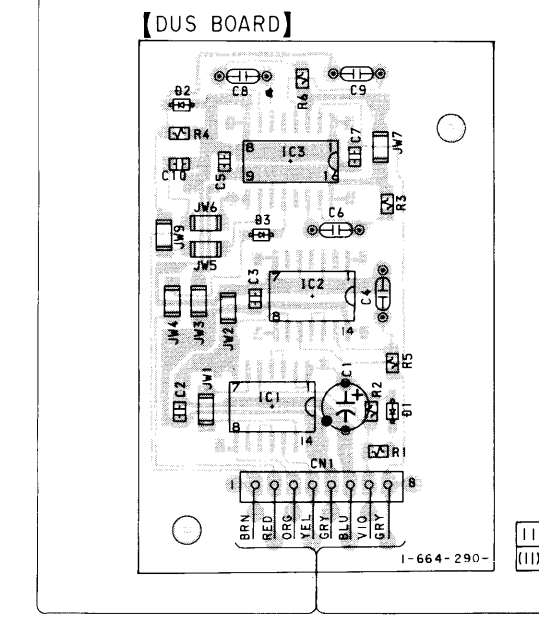
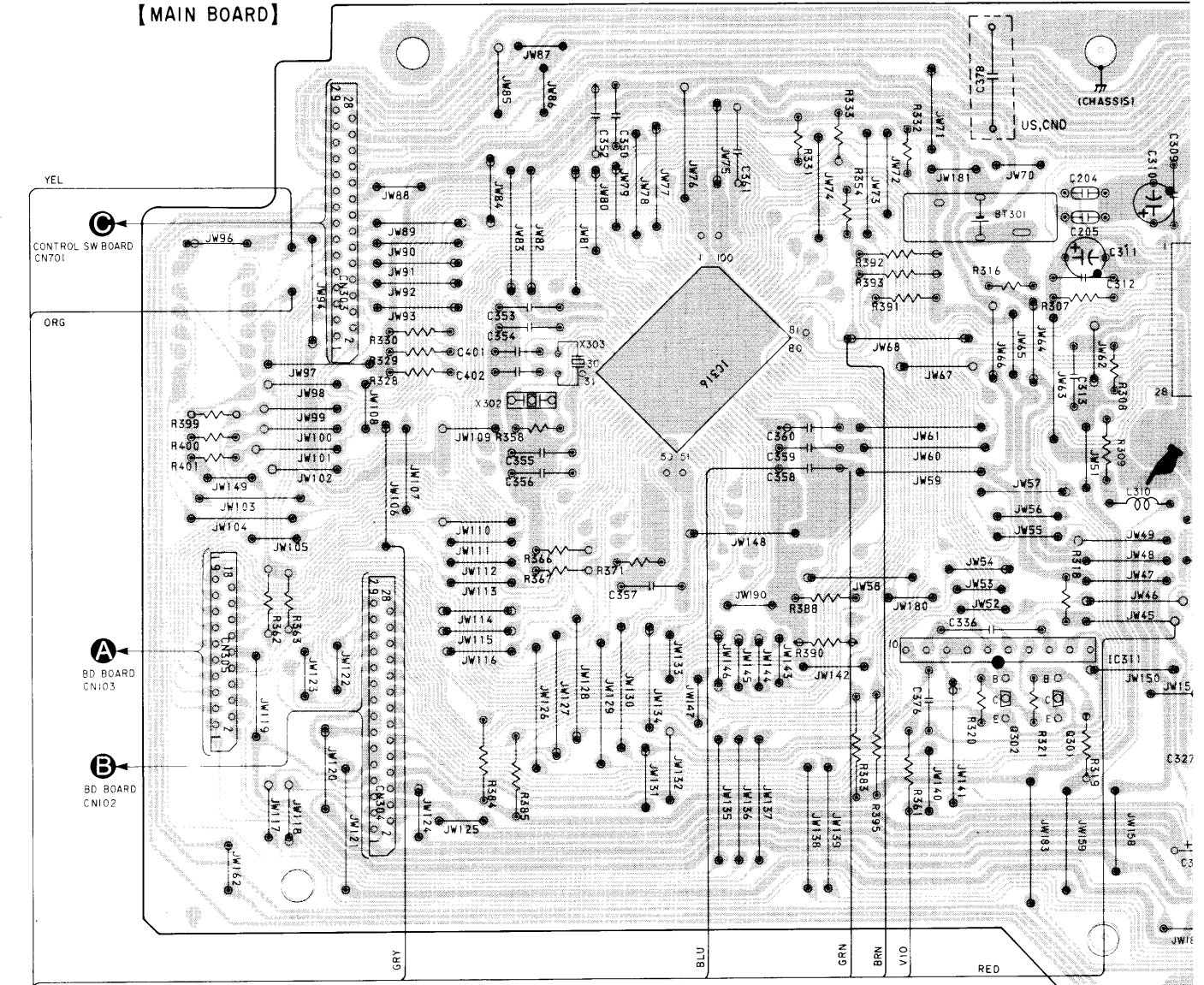

[MAIN BOARD] - Suffix No. - 13, - 14, - 21 -

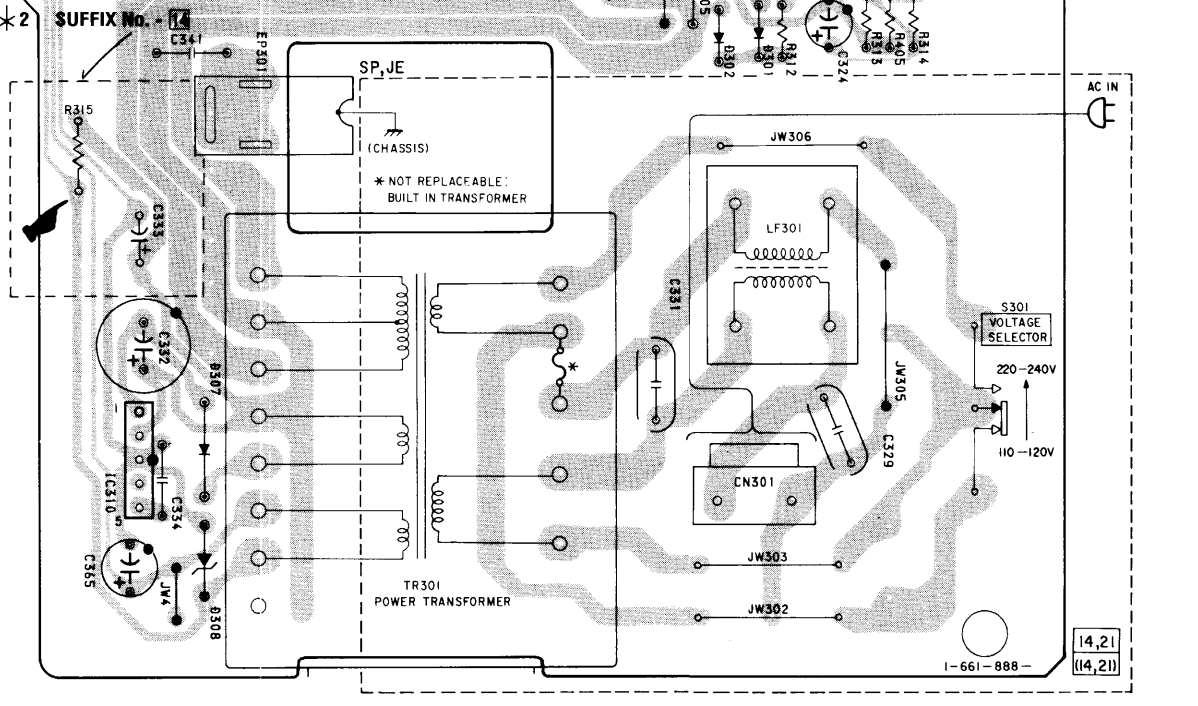
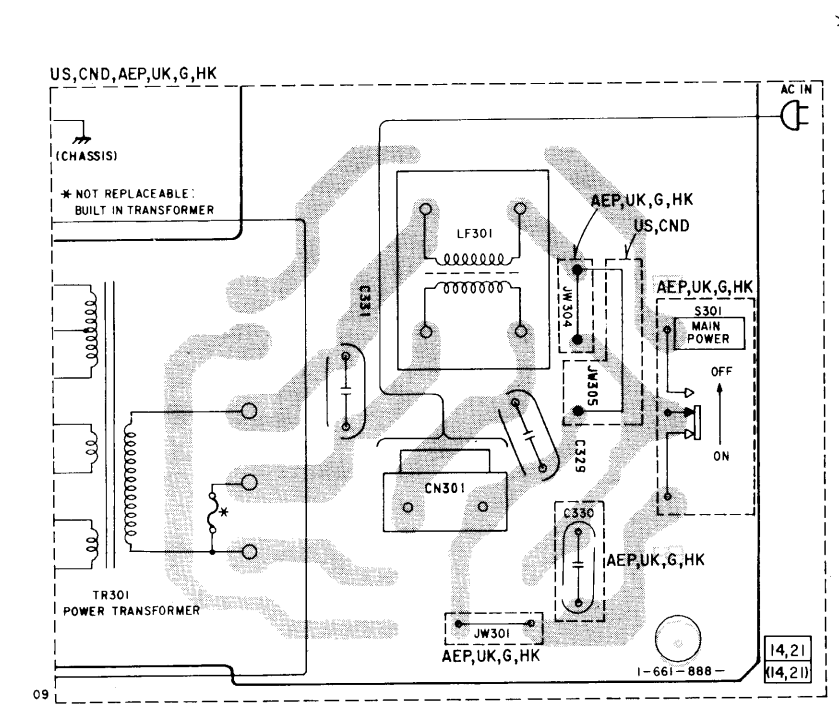
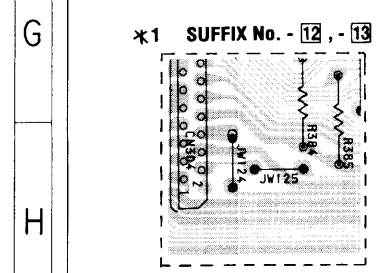
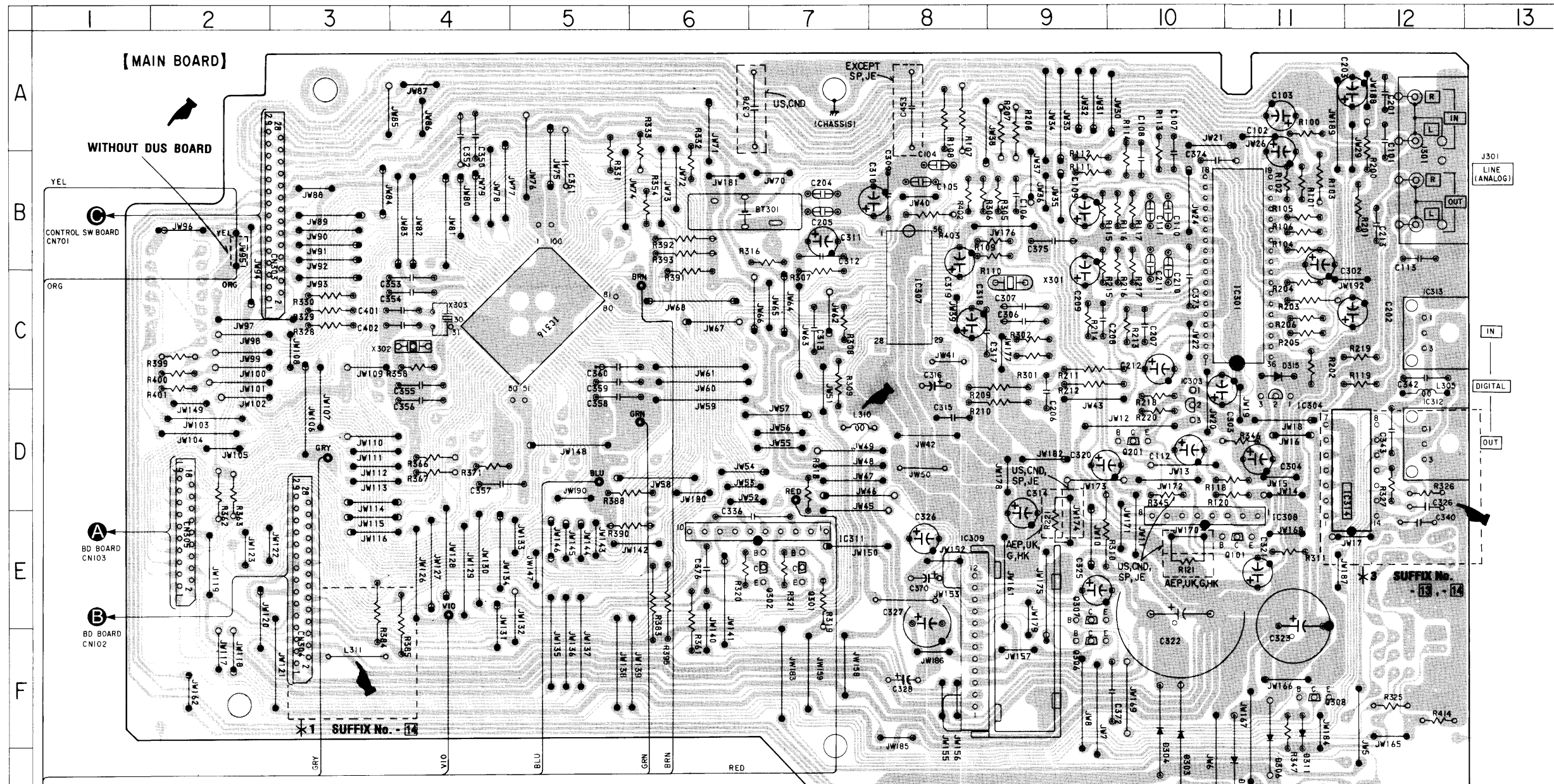

• Semiconductor Location

Ref. No.	Location
D301	G-11
D302	G-11
D303	G-10
D304	G-10
D305	G-11
D306	G-11
D307	I-8
D308	J-8
D311	G-11
D315	C-11
IC301	C-11
IC303	D-10
IC304	D-11
IC307	C-8
IC308	E-11
IC309	E-8
IC310	I-7
IC311	E-7
IC312	D-12
IC313	C-12
IC314	D-11
IC316	C-5
Q101	E-11
Q102	D-10
Q301	E-7
Q302	E-7
Q306	F-9
Q307	E-9
Q308	F-11

• Parts No. Location [MAIN BOARD] (Component side)

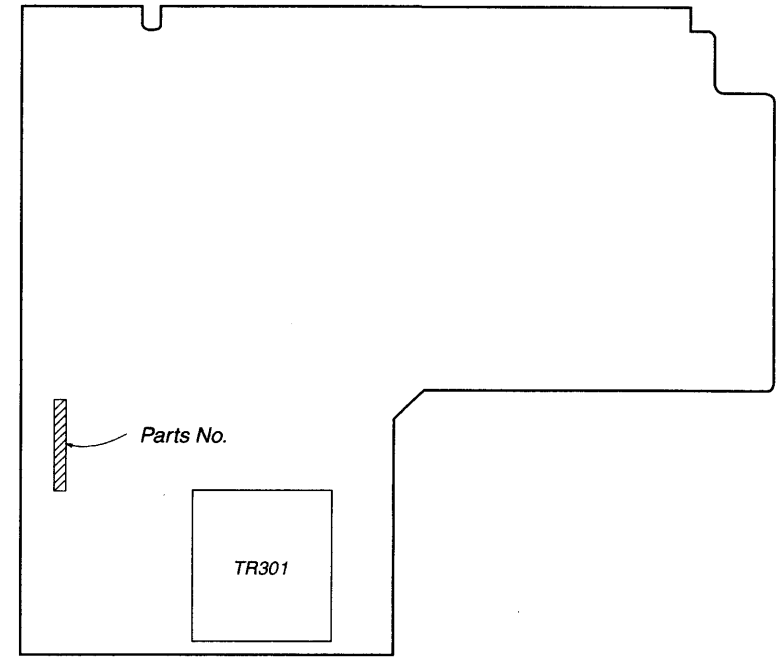

- Note:
- : parts extracted from the component side.
 - : parts mounted on the conductor side.
 - ▨ : Pattern from the side which enable seeing.
 - Abbreviation
 CND : Canadian model.
 G : German model.
 SP : Singapore model.
 HK : Hong Kong model.
 JE : Tourist model.

SCHEMATIC DIAGRAM — MAIN SECTION —
: indicates changed portion.

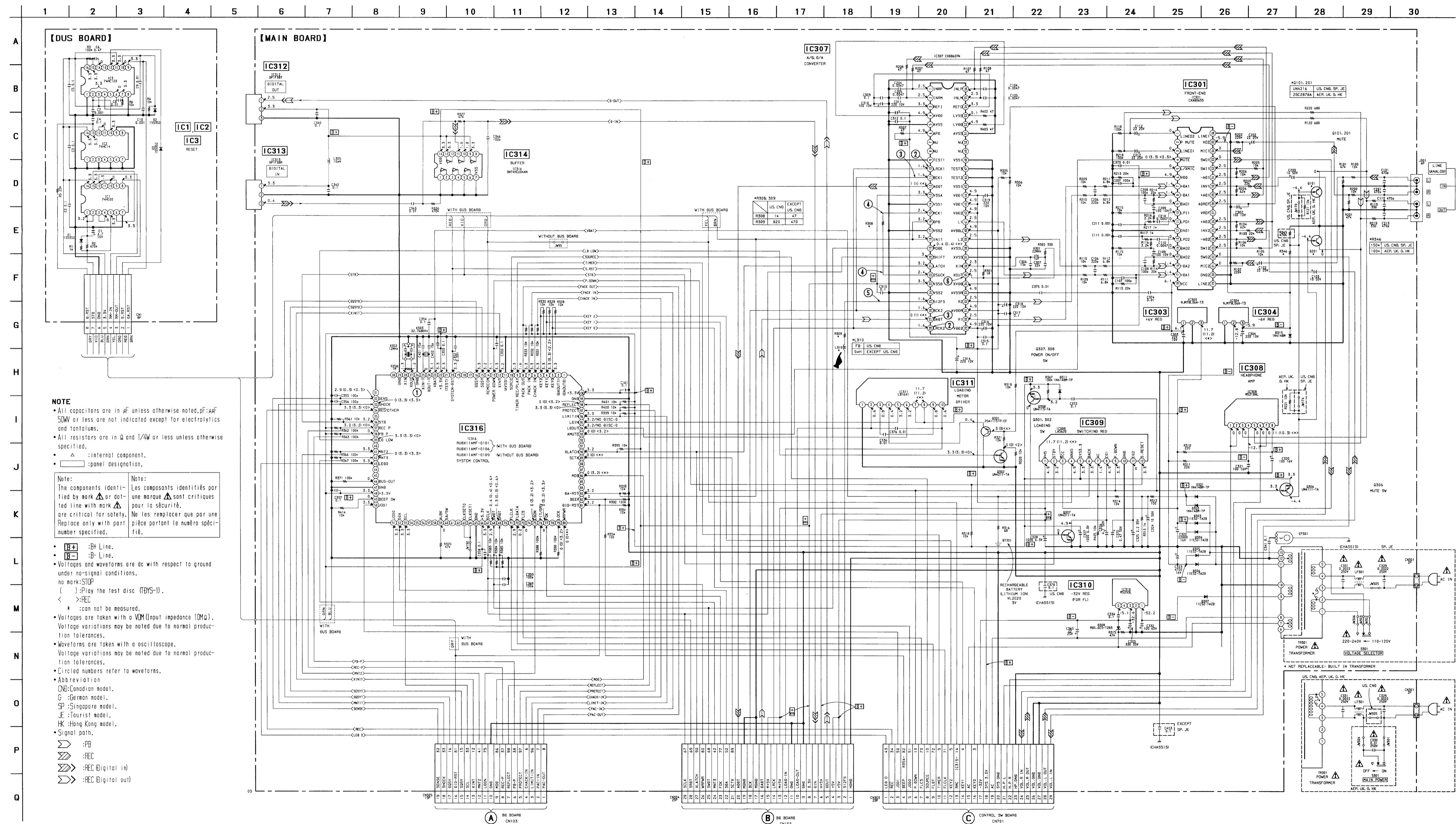

NOTE

- All capacitors are in μF unless otherwise noted; μF : μF 50W or less are not indicated except for electrolytics and tantalums.
- All resistors are in Ω and $1/W$ or less unless otherwise specified.
- Δ : internal component.
- \square : panel designation.

Note: The components identified by mark Δ or \square are critical for safety. Replace only with part number specified.

Note: Les composants identifiés par une marque Δ sont critiques pour la sécurité. Ne les remplacer que par une pièce portant le numéro spécifié.

- \square : B+ Line.
- \square : B- Line.
- Voltages and waveforms are do with respect to ground under no-signal conditions. no mark: STOP () : Play the test disc (TDS-1). < : REC * : can not be measured.
- Voltages are taken with a VOM (input impedance 10M Ω). Voltage variations may be noted due to normal production tolerances.
- Waveforms are taken with a oscilloscope. Voltage variations may be noted due to normal production tolerances.
- Circled numbers refer to waveforms.
- Abbreviation CND: Canadian model, G : German model, S : Singapore model, JE : Tourist model, HK : Hong Kong model.
- Signal path.
- \gg : PB
- \gg : REC
- \gg : REC @digital in
- \gg : REC @digital out

— PANEL SECTION —
 : indicates changed portion.

[PANEL BOARD] – Suffix No. - **11** -

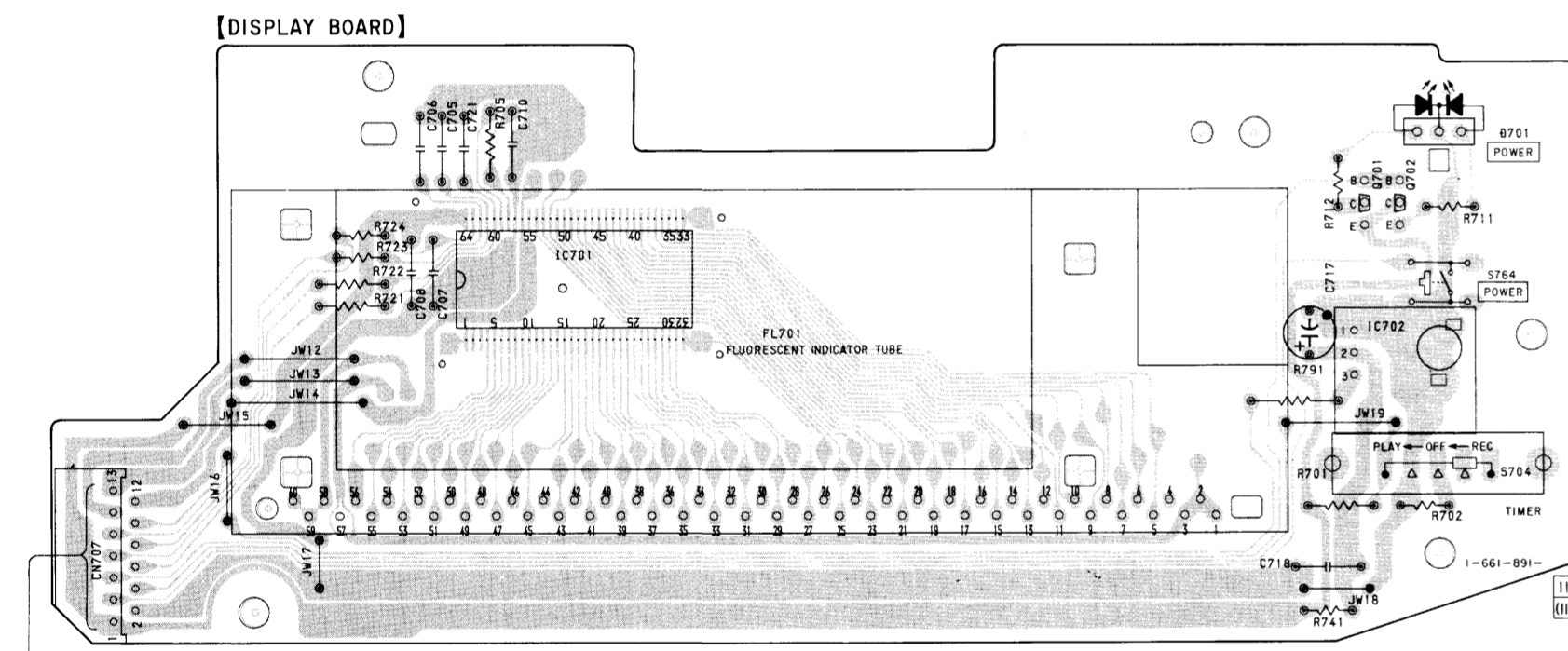

[PANEL BOARD] – Suffix No. - **12** -

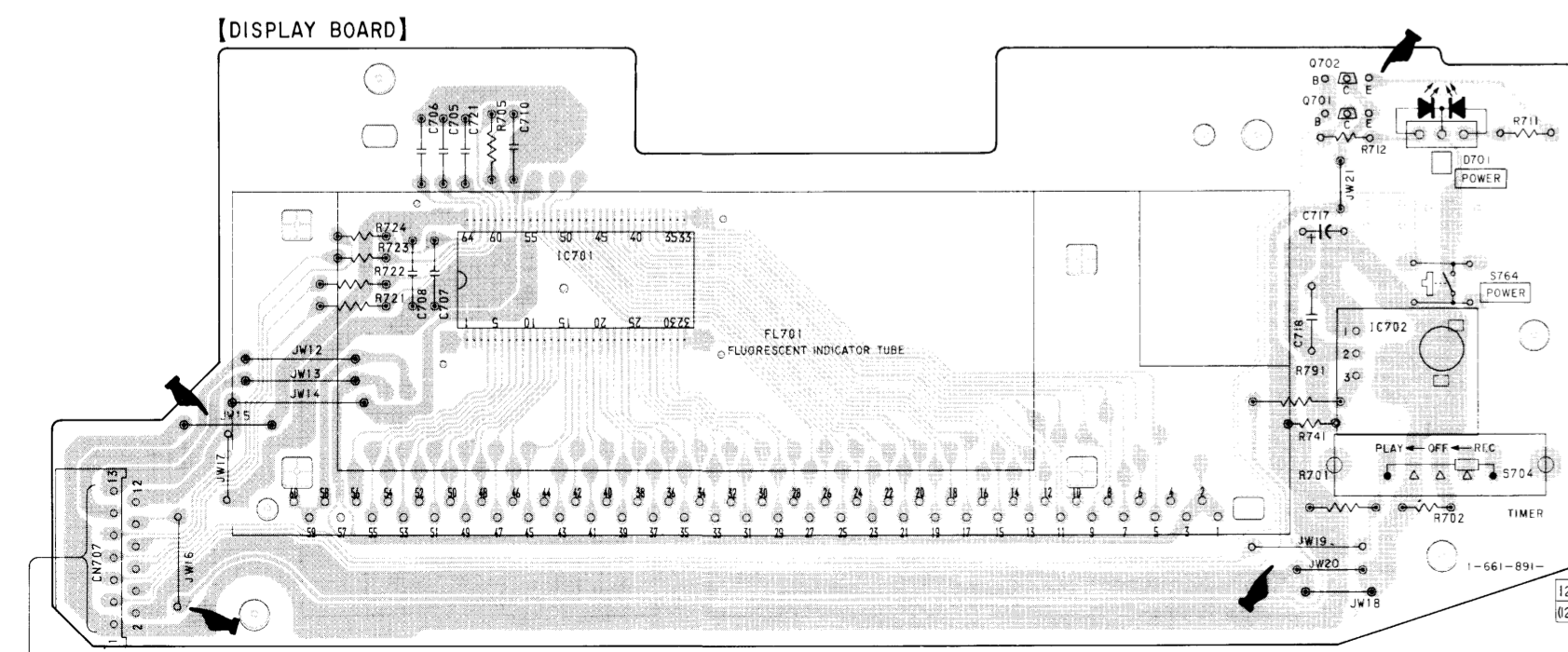

[PANEL BOARD] – Suffix No. - **13** -

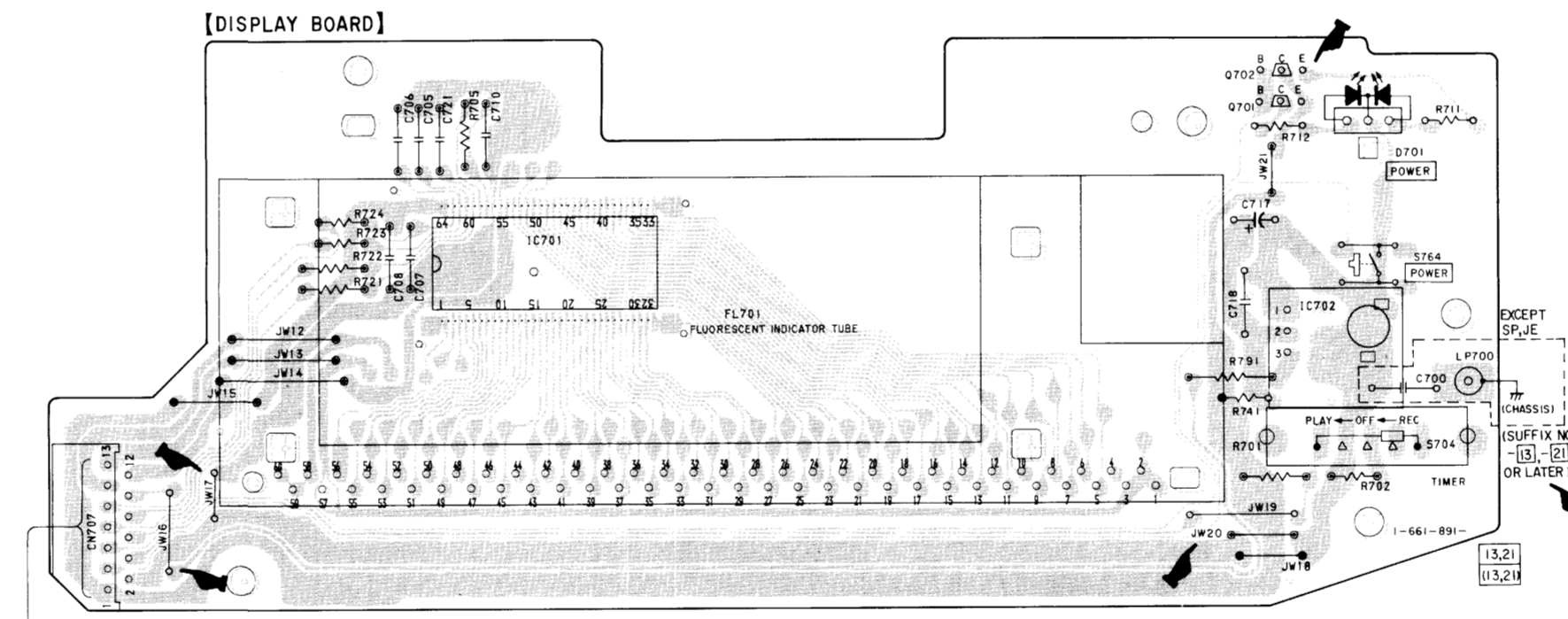

 : indicates changed portion.

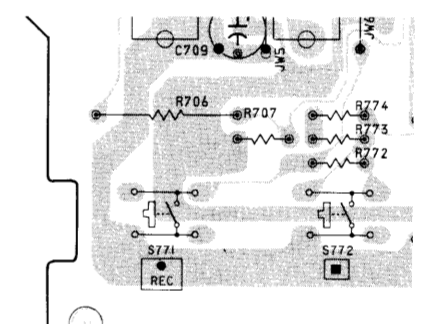
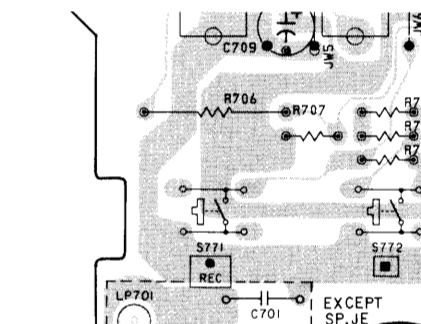
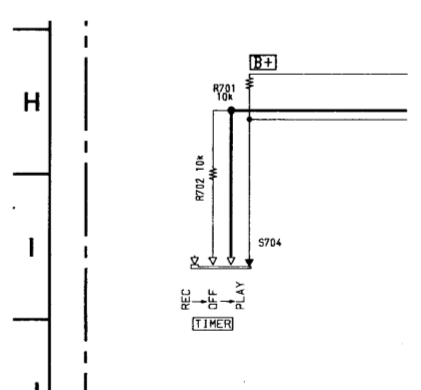
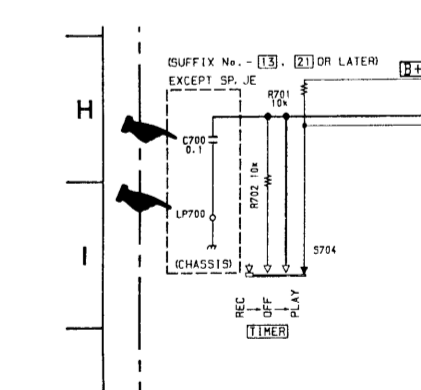
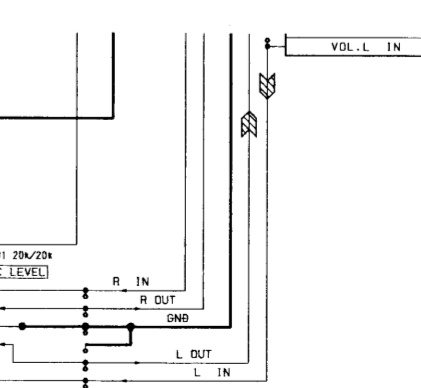
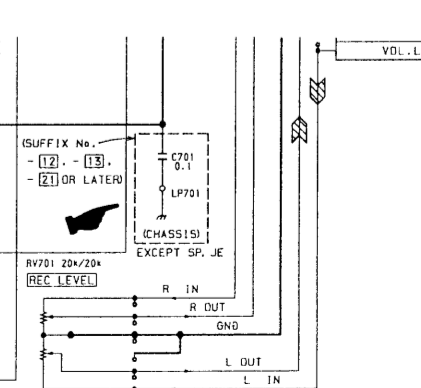
Page	FORMER	NEW
49	<p>[CONTROL SW BOARD] Location : H, 3-4</p>  <p>1-661-890-11 (11)</p>	<p>[CONTROL SW BOARD] Location : H, 3-4</p>  <p>1-661-890-12, 13, 21 (12), (13), (21)</p>
51	<p>[DISPLAY BOARD] Location : H-I, 1-2</p> 	<p>[DISPLAY BOARD] Location : H-I, 1-2</p>  <p>*NOTE : As for installing position, refer to PRINTED WIRING BOARD on page 21 to 23.</p>
52	<p>[CONTROL SW BOARD] Location : H-I, 15-16</p> 	<p>[CONTROL SW BOARD] Location : H-I, 15-16</p> 

Page	FORMER				NEW				
	Ref. No.	Part No.	Description	Remark	Ref. No.	Part No.	Description	Remark	
72	*** ELECTRICAL PARTS LIST ***				*** ELECTRICAL PARTS LIST ***				
	*	A-4699-142-A	CONTROL SW BOARD, COMPLETE		*	A-4699-142-A	CONTROL SW BOARD, COMPLETE (SP,JE)		
					*	A-4699-525-A	CONTROL SW BOARD, COMPLETE (AEP,UK,G,HK)		
					*	A-4699-528-A	CONTROL SW BOARD, COMPLETE (US,CND)		
					C701	1-164-159-11	CERAMIC 0.1uF 50V (EXCEPT SP,JE)		
	*	A-4699-141-A	DISPLAY BOARD, COMPLETE		*	A-4699-141-A	DISPLAY BOARD, COMPLETE (SP,JE)		
					*	A-4699-524-A	DISPLAY BOARD, COMPLETE (AEP,UK,G,HK)		
					*	A-4699-527-A	DISPLAY BOARD, COMPLETE (US,CND)		
					C700	1-164-159-11	CERAMIC 0.1uF 50V (EXCEPT SP,JE)		
					LP700	1-690-880-41	LEAD (WITH CONNECTOR) (EXCEPT SP,JE)		

MAIN

ELECTRICAL PARTS LIST

Note:

The components identified by mark Δ or dotted line with mark Δ are critical for safety. Replace only with part number specified.

Les composants identifiés par une marque Δ sont critiques pour la sécurité. Ne les remplacer que par une pièce portant le numéro spécifié.

When indicating parts by reference number, please include the board name.

- Due to standardization, replacements in the parts list may be different from the parts specified in the diagrams or the components used on the set.
- Items marked "*" are not stocked since they are seldom required for routine service. Some delay should be anticipated when ordering these items.
- RESISTORS
All resistors are in ohms
METAL: Metal-film resistor
METAL OXIDE: Metal Oxide-film resistor
F : nonflammable
- SEMICONDUCTORS
In each case, u: μ , for example:
uA...: μ A..., uPA...: μ PA..., uPB...: μ PB..., uPC...: μ PC..., uPD...: μ PD...
- CAPACITORS
uF : μ F
- COILS
uH : μ H
- Abbreviation
CND : Canadian model
G : German model
HK : Hong Kong model
SP : Singapore model
JE : Tourist model

Ref. No.	Part No.	Description	Remark	Ref. No.	Part No.	Description	Remark
*	A-4699-146-A	MAIN BOARD, COMPLETE (AEP,G,UK,HK) *****		C206	1-136-437-11	FILM	220PF 5% 630V (AEP,G,UK,HK)
*	A-4699-147-A	MAIN BOARD, COMPLETE (SP,JE) *****		C207	1-102-973-00	CERAMIC	100PF 5% 50V (US,CND,SP,JE)
*	A-4699-273-A	MAIN BOARD, COMPLETE (US,CND) *****		C207	1-136-433-11	FILM	100PF 5% 630V (AEP,G,UK,HK)
	7-685-872-09	SCREW +BVTT 3X8 (S)		C208	1-102-973-00	CERAMIC	100PF 5% 50V (US,CND,SP,JE)
		< BATTERY >		C208	1-136-433-11	FILM	100PF 5% 630V (AEP,G,UK,HK)
BT301	1-528-739-11	BATTERY, LITHIUM (VL2020 3V)		C209	1-126-933-11	ELECT	100uF 20% 10V
		< CAPACITOR >		C210	1-137-368-11	FILM	0.0047uF 5% 50V
C101	1-130-467-00	MYLAR	470PF 5% 50V	C211	1-137-364-11	FILM	0.001uF 5% 50V
C102	1-128-551-11	ELECT	22uF 20% 25V	C212	1-128-551-11	ELECT	22uF 20% 25V
C103	1-126-964-11	ELECT	10uF 20% 50V	C213	1-130-467-00	MYLAR	470PF 5% 50V
C104	1-137-368-11	FILM	0.0047uF 5% 50V	C302	1-126-933-11	ELECT	100uF 20% 10V
C105	1-137-368-11	FILM	0.0047uF 5% 50V	C303	1-126-923-11	ELECT	220uF 20% 10V
C106	1-102-978-00	CERAMIC	220PF 5% 50V (US,CND,SP,JE)	C304	1-126-923-11	ELECT	220uF 20% 10V
C106	1-136-437-11	FILM	220PF 5% 630V (AEP,G,UK,HK)	C306	1-162-203-31	CERAMIC	15PF 5% 50V
C107	1-102-973-00	CERAMIC	100PF 5% 50V (US,CND,SP,JE)	C307	1-162-207-31	CERAMIC	22PF 5% 50V
C107	1-136-433-11	FILM	100PF 5% 630V (AEP,G,UK,HK)	C309	1-164-159-11	CERAMIC	0.1uF 50V
C108	1-102-973-00	CERAMIC	100PF 5% 50V (US,CND,SP,JE)	C310	1-126-933-11	ELECT	100uF 20% 10V
C108	1-136-433-11	FILM	100PF 5% 630V (AEP,G,UK,HK)	C311	1-126-923-11	ELECT	220uF 20% 10V
C109	1-126-933-11	ELECT	100uF 20% 10V	C312	1-164-159-11	CERAMIC	0.1uF 50V
C110	1-137-368-11	FILM	0.0047uF 5% 50V	C313	1-164-159-11	CERAMIC	0.1uF 50V
C111	1-137-364-11	FILM	0.001uF 5% 50V	C314	1-126-923-11	ELECT	220uF 20% 10V
C112	1-128-551-11	ELECT	22uF 20% 25V	C315	1-164-159-11	CERAMIC	0.1uF 50V
C113	1-130-467-00	MYLAR	470PF 5% 50V	C316	1-126-923-11	ELECT	220uF 20% 10V
C201	1-130-467-00	MYLAR	470PF 5% 50V	C317	1-164-159-11	CERAMIC	0.1uF 50V
C202	1-128-551-11	ELECT	22uF 20% 25V	C318	1-126-923-11	ELECT	220uF 20% 10V
C203	1-126-964-11	ELECT	10uF 20% 50V	C319	1-126-923-11	ELECT	220uF 20% 10V
C204	1-137-368-11	FILM	0.0047uF 5% 50V	C320	1-126-933-11	ELECT	100uF 20% 16V
C205	1-137-368-11	FILM	0.0047uF 5% 50V	C321	1-126-933-11	ELECT	100uF 20% 16V
C206	1-102-978-00	CERAMIC	220PF 5% 50V (US,CND,SP,JE)	C322	1-115-364-11	ELECT	22000uF 20% 16V
				C323	1-126-937-11	ELECT	4700uF 20% 16V
				C324	1-126-964-11	ELECT	10uF 20% 50V
				C325	1-131-349-00	TANTALUM	2.2uF 10% 35V
				C326	1-126-963-11	ELECT	4.7uF 20% 50V
				C327	1-126-916-11	ELECT	1000uF 20% 6.3V
				C328	1-126-916-11	ELECT	1000uF 20% 6.3V
				Δ C329	1-113-920-11	CERAMIC	0.0022uF 20% 250V
				Δ C330	1-113-925-11	CERAMIC	0.01uF 20% 250V (AEP,G,UK,HK)

Ref. No.	Part No.	Description	Remark		
△C331	1-113-920-11	CERAMIC	0.0022uF	20%	250V
C332	1-128-576-11	ELECT	100uF	20%	63V
C333	1-126-950-11	ELECT	330uF	20%	35V
C334	1-164-159-11	CERAMIC	0.1uF		50V
C336	1-162-306-11	CERAMIC	0.01uF	20%	16V
C340	1-164-159-11	CERAMIC	0.1uF		50V
C341	1-164-159-11	CERAMIC	0.1uF		50V
C342	1-164-159-11	CERAMIC	0.1uF		50V
C343	1-162-306-11	CERAMIC	0.01uF	20%	16V
C346	1-162-282-31	CERAMIC	100PF	10%	50V
C350	1-164-159-11	CERAMIC	0.1uF		50V
C352	1-162-294-31	CERAMIC	0.001uF	10%	50V
C353	1-164-159-11	CERAMIC	0.1uF		50V
C354	1-164-159-11	CERAMIC	0.1uF		50V
C355	1-162-282-31	CERAMIC	100PF	10%	50V
C356	1-162-282-31	CERAMIC	100PF	10%	50V
C357	1-164-159-11	CERAMIC	0.1uF		50V
C358	1-164-159-11	CERAMIC	0.1uF		50V
C359	1-162-282-31	CERAMIC	100PF	10%	50V
C360	1-162-282-31	CERAMIC	100PF	10%	50V
C361	1-164-159-11	CERAMIC	0.1uF		50V
C365	1-128-551-11	ELECT	22uF	20%	25V
C370	1-126-959-11	ELECT	0.47uF	20%	50V
C372	1-164-159-11	CERAMIC	0.1uF		50V
C373	1-162-306-11	CERAMIC	0.01uF	20%	16V
C374	1-162-306-11	CERAMIC	0.01uF	20%	16V
C375	1-162-306-11	CERAMIC	0.01uF	20%	16V
C376	1-162-306-11	CERAMIC	0.01uF	20%	16V
C378	1-164-159-11	CERAMIC	0.1uF		50V (US,CND)
C401	1-162-203-31	CERAMIC	15PF	5%	50V
C402	1-162-203-31	CERAMIC	15PF	5%	50V
C453	1-164-159-11	CERAMIC	0.1uF		50V (US,CND,AEP,UK,G,HK)
< CONNECTOR >					
CN301	1-580-230-11	PIN, CONNECTOR (PC BOARD) 2P			
CN303	1-770-657-11	CONNECTOR, FFC/FPC 29P			
CN304	1-770-657-11	CONNECTOR, FFC/FPC 29P			
CN305	1-770-167-11	CONNECTOR, FFC/FPC 19P			
< DIODE >					
D301	8-719-987-63	DIODE	1N4148M		
D302	8-719-987-63	DIODE	1N4148M		
D303	8-719-200-82	DIODE	11ES2		
D304	8-719-200-82	DIODE	11ES2		
D305	8-719-200-82	DIODE	11ES2		
D306	8-719-200-82	DIODE	11ES2		
D307	8-719-200-82	DIODE	11ES2		
D308	8-719-109-89	DIODE	RD5.6ESB2		
D311	8-719-987-63	DIODE	1N4148M		
D315	8-719-987-63	DIODE	1N4148M		

Ref. No.	Part No.	Description	Remark		
< GROUND PLATE >					
* EP301	4-962-200-01	PLATE (TR), GROUND			
< IC >					
IC301	8-759-434-43	IC	CXA8065S		
IC303	8-759-708-06	IC	NJM78L06A		
IC304	8-759-700-69	IC	NJM79L12A		
IC307	8-759-426-99	IC	CXD8607N		
IC308	8-759-634-50	IC	M5218AL		
IC309	8-759-426-96	IC	LA5620		
IC310	8-759-633-42	IC	M5293L		
IC311	8-759-822-09	IC	LB1641		
IC312	8-749-012-69	IC	GP1F38T (DIGITAL OUT)		
IC313	8-749-012-70	IC	GP1F38R (DIGITAL IN)		
IC314	8-759-917-18	IC	SN74HCU04AN		
IC316	8-759-451-86	IC	RU8X11AMF-0109		
< JACK >					
J301	1-770-720-11	JACK, PIN 4P (LINE (ANALOG) IN/OUT)			
< COIL >					
L305	1-410-509-11	INDUCTOR	10uH		
L310	1-410-397-21	FERRITE BEAD INDUCTOR (US,CND)			
L310	1-412-473-51	INDUCTOR	0uH (EXCEPT US,CND)		
< LINE FILTER >					
△LF301	1-424-485-11	FILTER, LINE			
< TRANSISTOR >					
Q101	8-729-141-30	TRANSISTOR	2SC3623A-LK (AEP,G,UK,HK)		
Q101	8-729-900-74	TRANSISTOR	DTC143TS (US,CND,SP,JE)		
Q201	8-729-141-30	TRANSISTOR	2SC3623A-LK (AEP,G,UK,HK)		
Q201	8-729-900-74	TRANSISTOR	DTC143TS (US,CND,SP,JE)		
Q301	8-729-119-76	TRANSISTOR	2SA1175-HFE		
Q302	8-729-900-80	TRANSISTOR	DTC114ES		
Q306	8-729-422-57	TRANSISTOR	UN4111		
Q307	8-729-900-80	TRANSISTOR	DTC114ES		
Q308	8-729-422-61	TRANSISTOR	UN4115		
< RESISTOR >					
R100	1-249-429-11	CARBON	10K	5%	1/4W
R101	1-249-437-11	CARBON	47K	5%	1/4W
R102	1-247-887-00	CARBON	220K	5%	1/4W
R103	1-249-433-11	CARBON	22K	5%	1/4W
R104	1-247-874-11	CARBON	62K	5%	1/4W
R105	1-249-429-11	CARBON	10K	5%	1/4W
R106	1-249-429-11	CARBON	10K	5%	1/4W
R107	1-249-401-11	CARBON	47	5%	1/4W F
R108	1-249-401-11	CARBON	47	5%	1/4W F
R109	1-249-429-11	CARBON	10K	5%	1/4W

The components identified by mark △ or dotted line with mark △ are critical for safety. Replace only with part number specified.	Les composants identifiés par une marque △ sont critiques pour la sécurité. Ne les remplacer que par une pièce portant le numéro spécifié.
--	--

MAIN

Ref. No.	Part No.	Description	Remark	Ref. No.	Part No.	Description	Remark
R110	1-249-429-11	CARBON	10K 5% 1/4W	R314	1-249-429-11	CARBON	10K 5% 1/4W
R111	1-249-427-11	CARBON	6.8K 5% 1/4W F	R315	1-249-437-11	CARBON	47K 5% 1/4W
R112	1-249-427-11	CARBON	6.8K 5% 1/4W F	R316	1-249-403-11	CARBON	68 5% 1/4W F
R113	1-247-862-11	CARBON	20K 5% 1/4W	R318	1-249-429-11	CARBON	10K 5% 1/4W
R114	1-247-862-11	CARBON	20K 5% 1/4W	R319	1-249-429-11	CARBON	10K 5% 1/4W
R115	1-249-429-11	CARBON	10K 5% 1/4W	R320	1-249-429-11	CARBON	10K 5% 1/4W
R116	1-249-421-11	CARBON	2.2K 5% 1/4W F	R321	1-249-429-11	CARBON	10K 5% 1/4W
R117	1-249-417-11	CARBON	1K 5% 1/4W F	R325	1-249-437-11	CARBON	47K 5% 1/4W
R118	1-249-441-11	CARBON	100K 5% 1/4W	R326	1-247-895-00	CARBON	470K 5% 1/4W
R119	1-249-411-11	CARBON	330 5% 1/4W	R327	1-249-437-11	CARBON	47K 5% 1/4W
R120	1-249-415-11	CARBON	680 5% 1/4W F	R328	1-249-429-11	CARBON	10K 5% 1/4W
R121	1-249-429-11	CARBON	10K 5% 1/4W (AEP,G,UK,HK)	R329	1-249-429-11	CARBON	10K 5% 1/4W
R200	1-249-429-11	CARBON	10K 5% 1/4W	R330	1-249-429-11	CARBON	10K 5% 1/4W
R201	1-249-437-11	CARBON	47K 5% 1/4W	R331	1-249-429-11	CARBON	10K 5% 1/4W
R202	1-247-887-00	CARBON	220K 5% 1/4W	R332	1-249-429-11	CARBON	10K 5% 1/4W
R203	1-249-433-11	CARBON	22K 5% 1/4W	R333	1-249-429-11	CARBON	10K 5% 1/4W
R204	1-247-874-11	CARBON	62K 5% 1/4W	R345	1-247-895-00	CARBON	470K 5% 1/4W (US,CND,SP,JE)
R205	1-249-429-11	CARBON	10K 5% 1/4W	R346	1-247-883-00	CARBON	150K 5% 1/4W (US,CND,SP,JE)
R206	1-249-429-11	CARBON	10K 5% 1/4W	R346	1-249-441-11	CARBON	100K 5% 1/4W (AEP,G,UK,HK)
R207	1-249-401-11	CARBON	47 5% 1/4W F	R347	1-249-441-11	CARBON	100K 5% 1/4W
R208	1-249-401-11	CARBON	47 5% 1/4W F	R354	1-247-807-31	CARBON	100 5% 1/4W
R209	1-249-429-11	CARBON	10K 5% 1/4W	R358	1-247-903-00	CARBON	1M 5% 1/4W
R210	1-249-429-11	CARBON	10K 5% 1/4W	R361	1-249-429-11	CARBON	10K 5% 1/4W
R211	1-249-427-11	CARBON	6.8K 5% 1/4W F	R362	1-249-441-11	CARBON	100K 5% 1/4W
R212	1-249-427-11	CARBON	6.8K 5% 1/4W F	R363	1-249-441-11	CARBON	100K 5% 1/4W
R213	1-247-862-11	CARBON	20K 5% 1/4W	R366	1-249-441-11	CARBON	100K 5% 1/4W
R214	1-247-862-11	CARBON	20K 5% 1/4W	R367	1-249-441-11	CARBON	100K 5% 1/4W
R215	1-249-429-11	CARBON	10K 5% 1/4W	R371	1-249-441-11	CARBON	100K 5% 1/4W
R216	1-249-421-11	CARBON	2.2K 5% 1/4W F	R383	1-249-429-11	CARBON	10K 5% 1/4W
R217	1-249-417-11	CARBON	1K 5% 1/4W F	R384	1-249-429-11	CARBON	10K 5% 1/4W
R218	1-249-441-11	CARBON	100K 5% 1/4W	R385	1-249-429-11	CARBON	10K 5% 1/4W
R219	1-249-411-11	CARBON	330 5% 1/4W	R388	1-249-441-11	CARBON	100K 5% 1/4W
R220	1-249-415-11	CARBON	680 5% 1/4W F	R390	1-249-441-11	CARBON	100K 5% 1/4W
R221	1-249-429-11	CARBON	10K 5% 1/4W (AEP,G,UK,HK)	R391	1-249-429-11	CARBON	10K 5% 1/4W
R301	1-247-903-00	CARBON	1M 5% 1/4W	R392	1-249-441-11	CARBON	100K 5% 1/4W
R302	1-249-411-11	CARBON	330 5% 1/4W	R393	1-249-429-11	CARBON	10K 5% 1/4W
R305	1-249-429-11	CARBON	10K 5% 1/4W	R395	1-249-429-11	CARBON	10K 5% 1/4W
R306	1-249-429-11	CARBON	10K 5% 1/4W	R399	1-249-429-11	CARBON	10K 5% 1/4W
R307	1-249-401-11	CARBON	47 5% 1/4W F	R400	1-249-429-11	CARBON	10K 5% 1/4W
R308	1-249-401-11	CARBON	47 5% 1/4W F (EXCEPT US,CND)	R401	1-249-429-11	CARBON	10K 5% 1/4W
R308	1-249-417-11	CARBON	1K 5% 1/4W F (US,CND)	R402	1-249-401-11	CARBON	47 5% 1/4W F
R309	1-249-413-11	CARBON	470 5% 1/4W F (EXCEPT US,CND)	R403	1-249-401-11	CARBON	47 5% 1/4W F
R309	1-249-416-11	CARBON	820 5% 1/4W F (US,CND)	R405	1-249-429-11	CARBON	10K 5% 1/4W
R310	1-249-409-11	CARBON	220 5% 1/4W F	R414	1-249-429-11	CARBON	10K 5% 1/4W
R311	1-249-409-11	CARBON	220 5% 1/4W F			< SWITCH >	
R312	1-247-807-31	CARBON	100 5% 1/4W	△ S301	1-572-675-11	SWITCH, POWER VOLTAGE CHANGE (VOLTAGE SELECTOR)(SP,JE)	
R313	1-249-417-11	CARBON	1K 5% 1/4W F	△ S301	1-762-764-11	SWITCH, POWER (MAIN POWER) (AEP,G,UK,HK)	

The components identified by mark △ or dotted line with mark △ are critical for safety. Replace only with part number specified.

Les composants identifiés par une marque △ sont critiques pour la sécurité. Ne les remplacer que par une pièce portant le numéro spécifié.

Ref. No. Part No. Description Remark

< TRANSFORMER >

- △TR301 1-429-735-11 TRANSFORMER, POWER (US,CND)
- △TR301 1-429-736-11 TRANSFORMER, POWER (AEP,G,UK,HK)
- △TR301 1-429-737-11 TRANSFORMER, POWER (SP,JE)

< VIBRATOR >

- X301 1-579-314-11 VIBRATOR, CRYSTAL (22MHz)
- X302 1-767-157-21 VIBRATOR, CERAMIC (12MHz)
- X303 1-567-098-61 VIBRATOR, CRYSTAL (32.768kHz)

The components identified by mark △ or dotted line with mark △ are critical for safety. Replace only with part number specified.	Les composants identifiés par une marque △ sont critiques pour la sécurité. Ne les remplacer que par une pièce portant le numéro spécifié.
--	--

5. ADDITION OF MALAYSIA PRODUCT MODEL

Difference table

Page	MADE IN JAPAN				MADE IN MALAYSIA			
	Ref. No.	Part No.	Description	Remark	Ref. No.	Part No.	Description	Remark
66	*** EXPLODED VIEWS ***				*** EXPLODED VIEWS ***			
	* 9	4-983-660-11	PANEL, BACK (US)		* 9	4-985-670-01	PANEL, BACK (US)	
	* 9	4-983-660-21	PANEL, BACK (CND)		* 9	4-985-670-11	PANEL, BACK (CND)	
	* 9	4-983-660-31	PANEL, BACK (AEP, G)		* 9	4-985-670-21	PANEL, BACK (AEP)	
	* 9	4-983-660-41	PANEL, BACK (UK)		* 9	4-985-670-31	PANEL, BACK (UK)	
	△12	1-751-275-11	CORD, POWER (AEP)		△12	1-575-651-51	CORD, POWER (AEP)	
76	*** ACSESSORIES & PACKING MATERIALS ***				*** ACSESSORIES & PACKING MATERIALS ***			
		1-558-271-11	CORD, CONNECTION (AUDIO 108cm)			1-776-263-11	CORD, CONNECTION (AUDIO 130cm)	

• Abbreviation

CND : Canadian model

G : German model

The components identified by mark △ or dotted line with mark △ are critical for safety. Replace only with part number specified.

Les composants identifiés par une marque △ sont critiques pour la sécurité. Ne les remplacer que par une pièce portant le numéro spécifié.

MEMO

