

MZ-E70

SERVICE MANUAL

Ver 1.2 2000.07

Hong Kong Model



The MZ-E70 (Hong Kong) model is approximately the same as MZ-E55 (Hong Kong) model. Consequently, only difference between MZ-E55 (Hong Kong) model and MZ-E70 (Hong Kong) model are listed.
For other information, please refer to the MZ-E55 service manual (9-924-958-12) previously issued.

PORTABLE MINIDISC PLAYER

SONY®



EXPLODED VIEWS (Service Manual See page 29)

☛ : Different portion

MAIN SECTION

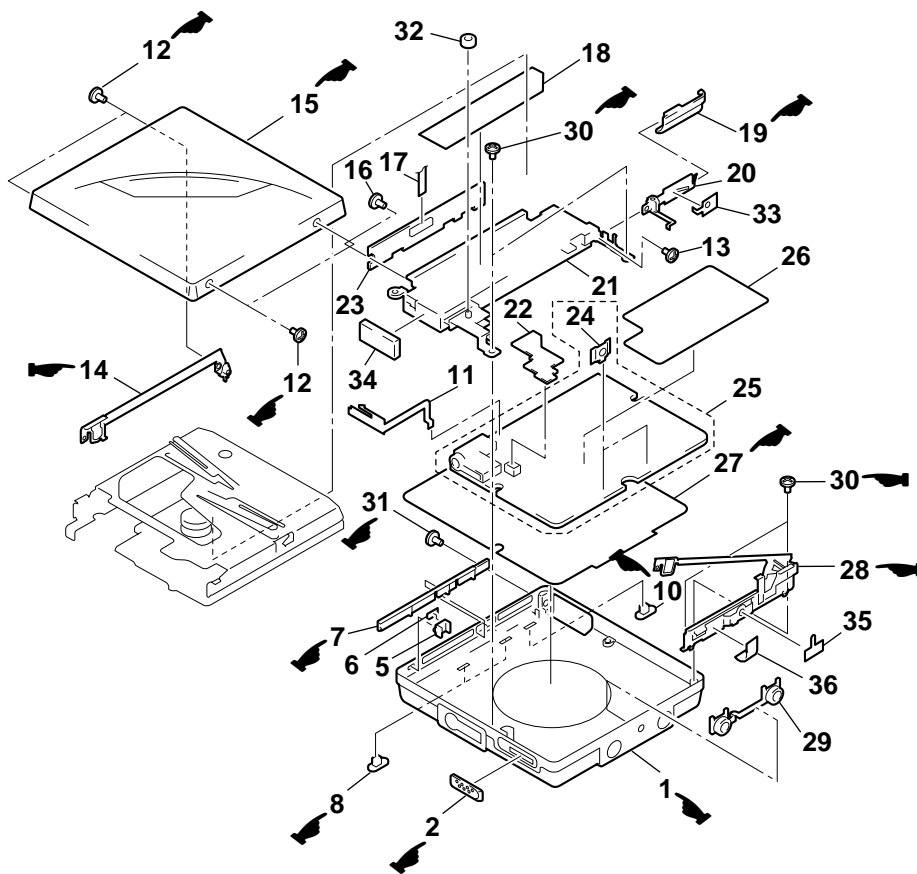

● DIFFERENCE PARTS LIST

EXPLODED VIEWS

MAIN SECTION (Service Manual See page 29)

Ref. No	MZ-E55 : Hong Kong Model		MZ-E70 : Hong Kong Model	
	Part No.	Description	Part No.	Description
1	4-212-867-01	PANEL, BOTTOM (GOLD)	X-4951-611-1	PANEL, BOTTOM (YELLOW)
	4-212-867-11	PANEL, BOTTOM (BLUE)	X-4951-612-1	PANEL, BOTTOM (BLUE)
			X-4951-613-1	PANEL, BOTTOM (WHITE)
2	4-212-872-01	KNOB, OPEN (GOLD)	4-994-801-01	KNOB, OPEN
	4-212-872-11	KNOB, OPEN (BLUE)		
3	X-4950-410-1	SLIDER ASSY, OPEN		
4	4-963-883-61	SCREW (M1.4), PRECISION PAN		
7	4-212-868-01	BUTTON, CONTROL (GOLD)	4-219-681-01	BUTTON, CONTROL
	4-212-868-11	BUTTON, CONTROL (BLUE)		
8	4-212-883-01	KNOB (HOLD) (GOLD)	4-219-679-01	KNOB (HOLD/ MB) (BLUE, YELLOW)
	4-212-883-11	KNOB (HOLD) (BLUE)	4-221-159-01	KNOB (HOLD/ MB) (WHITE)
9	4-212-882-01	KNOB (MB) (GOLD)		
	4-212-882-11	KNOB (MB) (BLUE)		
10	4-213-653-01	KNOB (AVLS) (GOLD)	4-219-680-01	KNOB (AVLS) (BLUE, YELLOW)
	4-213-653-11	KNOB (AVLS) (BLUE)	4-221-160-01	KNOB (AVLS) (WHITE)
12	4-963-883-21	SCREW (M1.4), PRECISION PAN (GOLD)	4-963-883-41	SCREW (M1.4), PRECISION PAN (YELLOW/WHITE)
	4-963-883-31	SCREW (M1.4), PRECISION PAN (BLUE)	4-963-883-51	SCREW (M1.4), PRECISION PAN (BLUE)
14	X-4950-413-1	PLATE (L) ASSY, FULCRUM	X-4951-521-1	PLATE (L) ASSY, FULCRUM
15	X-4950-578-2	UPPER PANEL ASSY (GOLD)	X-4951-608-1	PANEL, UPPER (YELLOW)
	X-4950-579-2	UPPER PANEL ASSY (BLUE)	X-4951-609-1	PANEL, UPPER (BLUE)
19	4-212-873-01	LID, BATTERY CASE (GOLD)	4-219-691-01	LID, BATTERY CASE (YELLOW)
	4-212-873-11	LID, BATTERY CASE (BLUE)	4-219-691-11	LID, BATTERY CASE (BLUE)
			4-219-691-21	LID, BATTERY CASE (WHITE)
27	4-212-870-01	SHEET, INSULATING	4-219-682-01	INSULATING SHEET
28	X-4950-419-1	PLATE (R) ASSY, FULCRUM	X-4951-520-1	PLATE (R) ASSY, FULCRUM
30	3-365-630-02	SCREW (M1.4) STEP	4-963-883-41	SCREW (M1.4), PRECISION PAN
31	3-365-630-21	SCREW (M1.4) STEP (GOLD)	4-963-883-41	SCREW (M1.4), PRECISION PAN (YELLOW/WHITE)
	3-365-630-31	SCREW (M1.4) STEP (BLUE)	4-963-883-51	SCREW (M1.4), PRECISION PAN (BLUE)

ACCESSORIES & PACKING MATERIALS (Service Manual See page 33)

MZ-E55 : Hong Kong Model		MZ-E70 : Hong Kong Model	
Part No.	Description	Part No.	Description
1-475-831-22	REMOTE CONTROL UNIT (RM-MZE55) (GOLD)	1-475-831-21	REMOTE CONTROL UNIT (RM-MZE55)
1-475-831-52	REMOTE CONTROL UNIT (RM-MZE55) (BLUE)		
1-528-743-11	BATTERY, NICKEL HYDROGEN	1-528-842-11	BATTERY, NICKEL HYDROGEN
3-865-053-61	MANUAL, INSTRUCTION (ENGLISH,CHINESE)	3-866-518-11	MANUAL, INSTRUCTION (ENGLISH,CHINESE)
8-953-218-90	HEADPHONE MDR-E838SP//K SET	8-953-304-90	RECEIVER MDR-E805SP SET

