

MZ-E77

SERVICE MANUAL

Ver 1.0 2000.03

E Model
Tourist Model



Photo: Silver type

US and foreign patents licensed from Dolby Laboratories Licensing Corporation.

Model Name Using Similar Mechanism	MZ-E90
MD Mechanism Type	MT-MZE90-166
Optical Pick-up Mechanism Type	LCX-2E

SPECIFICATIONS

System

Audio playing system

MiniDisc digital audio system

Laser diode properties

Material: GaAlAs

Wavelength: $\lambda = 790$ nm

Emission duration: continuous

Laser output: less than $44.6 \mu\text{W}^*$

* This output is the value measured at a distance of 200 mm from the objective lens surface on the optical pick-up block with 7 mm aperture.

Revolutions

600 rpm to 2250 rpm

Error correction

Advanced Cross Interleave Reed Solomon Code (ACIRC)

Sampling frequency

44.1 kHz

Coding

Adaptive TRansform Acoustic Coding (ATRAC)

Modulation system

EFM (Eight to Fourteen Modulation)

Number of channels

2 stereo channels

1 monaural channel

Frequency response

20 to 20,000 Hz ± 3 dB

Wow and Flutter

Below measurable limit

Outputs

Headphones: stereo mini-jack, maximum output level 5 mW + 5 mW, load impedance 16 ohms

General

Power requirements

Nickel metal hydride rechargeable battery

NH-14WM (supplied)

One LR6 (size AA) battery (not supplied)

Sony AC Power Adaptor AC-E15L* (not supplied) connected to the DC IN 1.5V jack

Battery operation time

Battery life*

Batteries	Playback
Ni-MH rechargeable battery (NH-14WM)	Approx. 21 hours**
One LR6 (size AA) alkaline battery	Approx. 31 hours
One LR6 (size AA) alkaline battery and a Ni-MH rechargeable battery (NH-14WM)	Approx. 56 hours**

* The battery life may be shorter depending on operating conditions and the temperature of the location.

** With a fully charged battery

Dimensions

Approx. 78.3 \times 13.9 \times 71.4 mm (w/h/d)
(3 ¹/₈ \times 9/16 \times 2 ⁷/₈ in.) not including projecting parts and controls

Mass

Approx. 85 g (3.0 oz.) the player only

Approx. 128 g (4.5 oz.) incl. a premastered MD and a nickel metal hydride rechargeable battery NH-14WM

Supplied accessories

Battery Charger (1)

Rechargeable battery (1)

Rechargeable battery carrying case (1)

Headphones with a remote control (1)

Dry battery case (1)

Carrying pouch (1)

Design and specifications are subject to change without notice.

PORTABLE MINIDISC PLAYER

SONY®

TABLE OF CONTENTS

1. SERVICING NOTES	3
2. GENERAL	4
3. DISASSEMBLY	5
4. TEST MODE	9
5. ELECTRICAL ADJUSTMENTS	14
6. DIAGRAMS	
6-1. Block Diagram –RF Section–	19
6-2. Block Diagram –SERVO Section –	21
6-3. Block Diagram –MAIN Section –	23
6-4. Printed Wiring Board –MAIN Board (Component Side) –	25
6-5. Printed Wiring Board –MAIN Board (Conductor Side) –	27
6-6. Schematic Diagram –MAIN Board (1/4) –	29
6-7. Schematic Diagram –MAIN Board (2/4) –	31
6-8. Schematic Diagram –MAIN Board (3/4) –	33
6-9. Schematic Diagram –MAIN Board (4/4) –	35
6-10. Printed Wiring Board –SYSTEM Board –	37
6-11. Schematic Diagram –SYSTEM Board –	39
6-12. Printed Wiring Board –SW Board –	41
6-13. Schematic Diagram –SW Board –	43
6-14. IC Pin Function Description	49
7. EXPLODED VIEWS	56
8. ELECTRICAL PARTS LIST	58

Features

- **Small body almost the size of a MiniDisc jacket**
Ideal weight and size; fits in your shirt pocket.
- **Personalized sound through Digital Sound Preset functions**
You can store two sets of sound quality adjustments (made during playback) to two switches.
- **Low power-consumption design enables extended battery life.**
- **Simple “One-Touch Eject” function for easy MiniDisc handling**
A single press of the OPEN button causes the player lid to open and the MiniDisc to eject.
- **Easy-to-operate headphones remote control with backlit LCD**
The LCD displays disc and track information, playback mode as well as battery condition. Keep the main unit in your pocket and operate the MiniDisc player through the “slim stick” remote control.
- **Shock-resistant memory offsets up to 40 seconds of optical read errors.**

SAFETY-RELATED COMPONENT WARNING!!

COMPONENTS IDENTIFIED BY MARK \triangle OR DOTTED LINE WITH MARK \triangle ON THE SCHEMATIC DIAGRAMS AND IN THE PARTS LIST ARE CRITICAL TO SAFE OPERATION. REPLACE THESE COMPONENTS WITH SONY PARTS WHOSE PART NUMBERS APPEAR AS SHOWN IN THIS MANUAL OR IN SUPPLEMENTS PUBLISHED BY SONY.

SECTION 1

SERVICING NOTES

NOTES ON HANDLING THE OPTICAL PICK-UP BLOCK OR BASE UNIT

The laser diode in the optical pick-up block may suffer electrostatic break-down because of the potential difference generated by the charged electrostatic load, etc. on clothing and the human body.

During repair, pay attention to electrostatic break-down and also use the procedure in the printed matter which is included in the repair parts.

The flexible board is easily damaged and should be handled with care.

NOTES ON LASER DIODE EMISSION CHECK

Never look into the laser diode emission from right above when checking it for adjustment. It is feared that you will lose your sight.

NOTES ON HANDLING THE OPTICAL PICK-UP BLOCK (LCX-2E)

The laser diode in the optical pick-up block may suffer electrostatic break-down easily. When handling it, perform soldering bridge to the laser-tap on the flexible board. Also perform measures against electrostatic break-down sufficiently before the operation. The flexible board is easily damaged and should be handled with care.

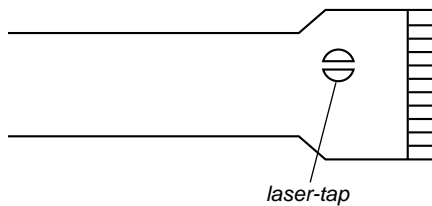

OPTICAL PICK-UP FLEXIBLE BOARD

CAUTION

Use of controls or adjustments or performance of procedures other than those specified herein may result in hazardous radiation exposure.

Flexible Circuit Board Repairing

- Keep the temperature of the soldering iron around 270 °C during repairing.
- Do not touch the soldering iron on the same conductor of the circuit board (within 3 times).
- Be careful not to apply force on the conductor when soldering or unsoldering.

Notes on chip component replacement

- Never reuse a disconnected chip component.
- Notice that the minus side of a tantalum capacitor may be damaged by heat.

- When repairing this set with the power on, if you remove the upper panel assy, this set stops working. In this case, you can work without the set stopping by fastening the hook of the open/close detect switch (SW board (S809)) with tape.

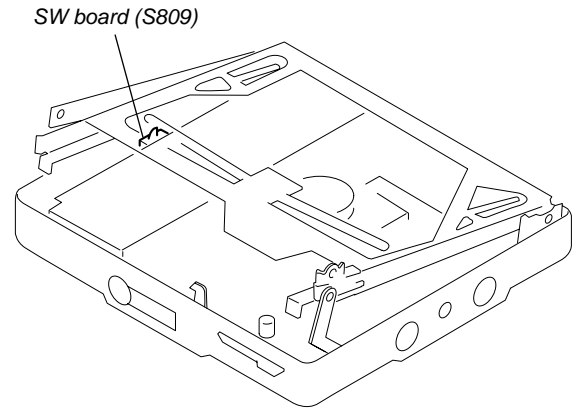

- This set is designed to perform automatic adjustment for each adjustment and write its value to EEPROM. Therefore, when EEPROM (IC802) has been replaced in service, be sure to perform automatic adjustment and write resultant values to the new EEPROM. After EEPROM (IC802) is replaced, digital sound preset setting value for display is changed to "00". Please make sure to check that digital sound preset setting value for display is "01". (Refer to page 14)
- Replacement of CXD2661GA-2 (IC601) and CXR701080-010GA (IC801) used in this set requires a special tool. Therefore, they cannot be replaced.

SECTION 2 GENERAL

LOCATION OF CONTROLS

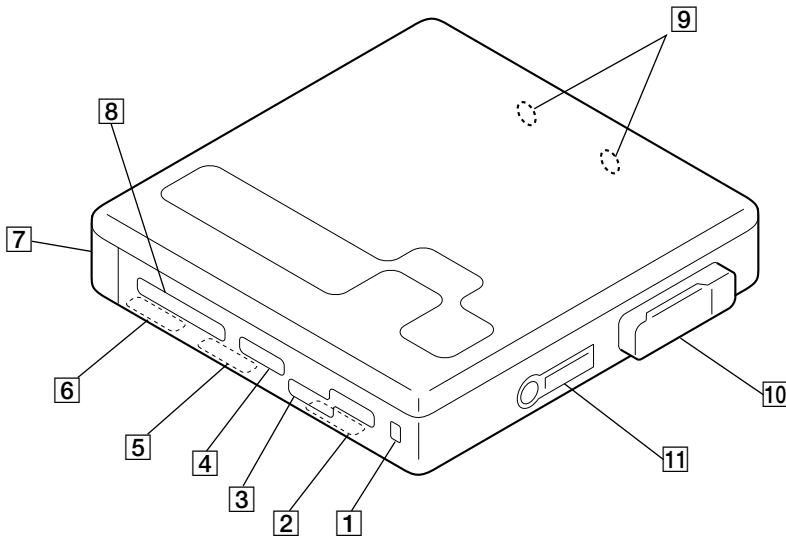

- | | |
|-------------------------------|-----------------------------|
| 1 OPR indicator | 7 Battery cover |
| 2 HOLD switch | 8 VOLUME +/- keys |
| 3 ►►/► and ◀◀◀ keys | 9 External battery terminal |
| 4 ■ key | 10 OPEN button |
| 5 DIGITAL SOUND PRESET switch | 11 ♫ (headphone) jack |
| 6 AVLS switch | |

Remote commander with headphones

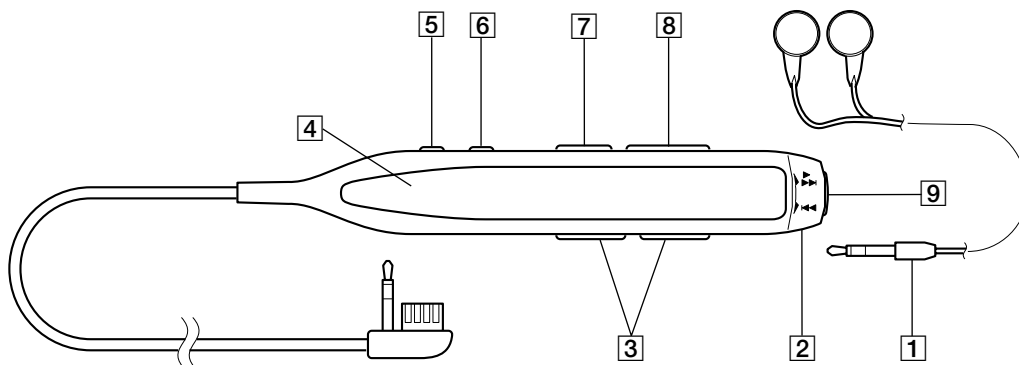

- | |
|--------------------|
| 1 Headphone |
| 2 ►►► and ◀◀◀ keys |
| 3 VOL +/- keys |
| 4 Display window |
| 5 DISPLAY key |
| 6 PLAYMODE key |
| 7 ■ key |
| 8 HOLD switch |
| 9 ■ key |

SECTION 3 DISASSEMBLY

Note: This set can be disassemble according to the following sequence.

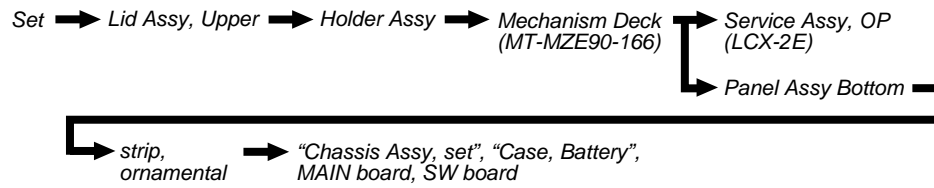

LID ASSY, UPPER

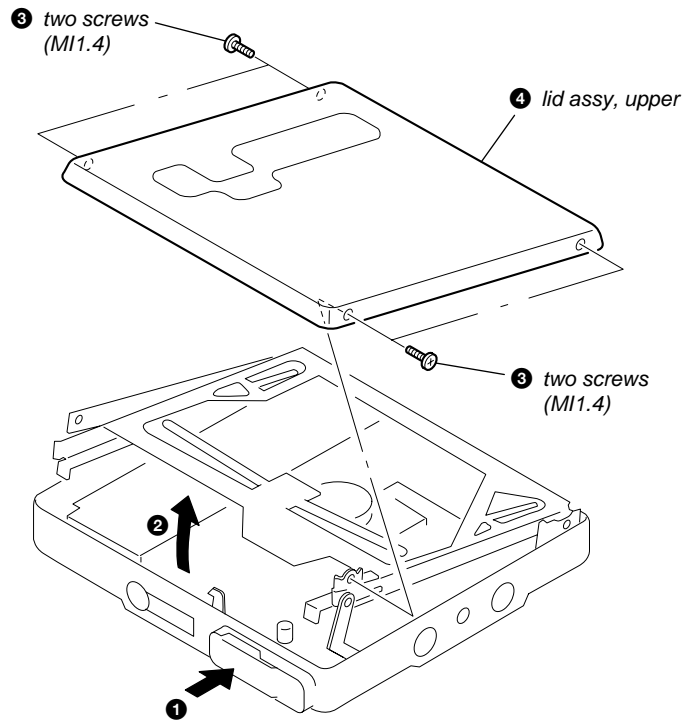

HOLDER ASSY

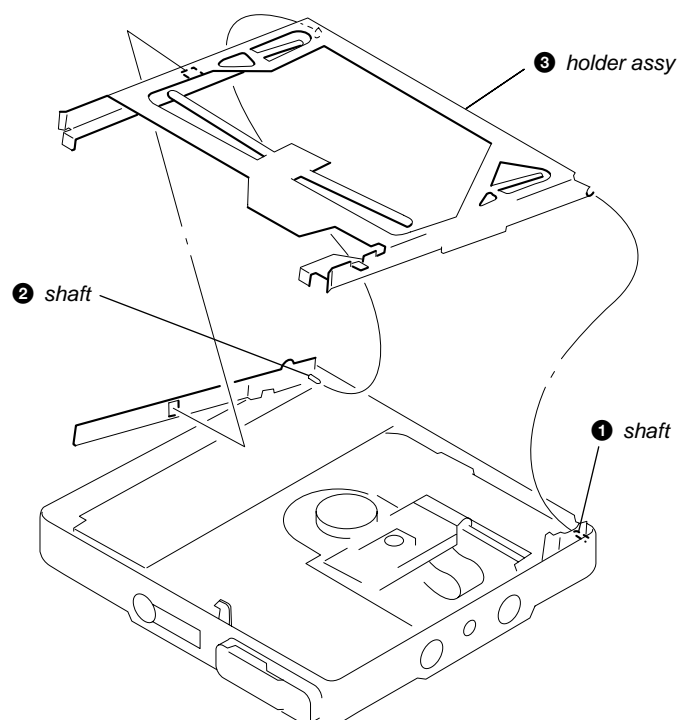

MECHANISM DECK (MT-MZE90-166)

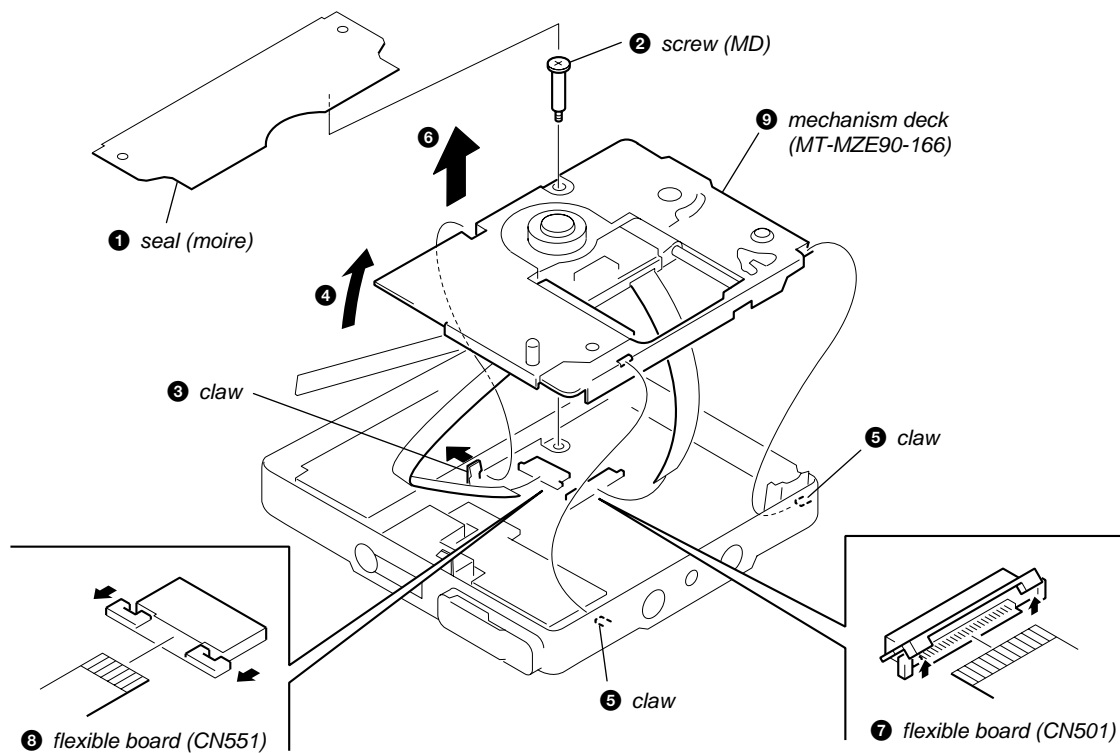

PANEL ASSY, BOTTOM

Note: When installing, fit three knobs.

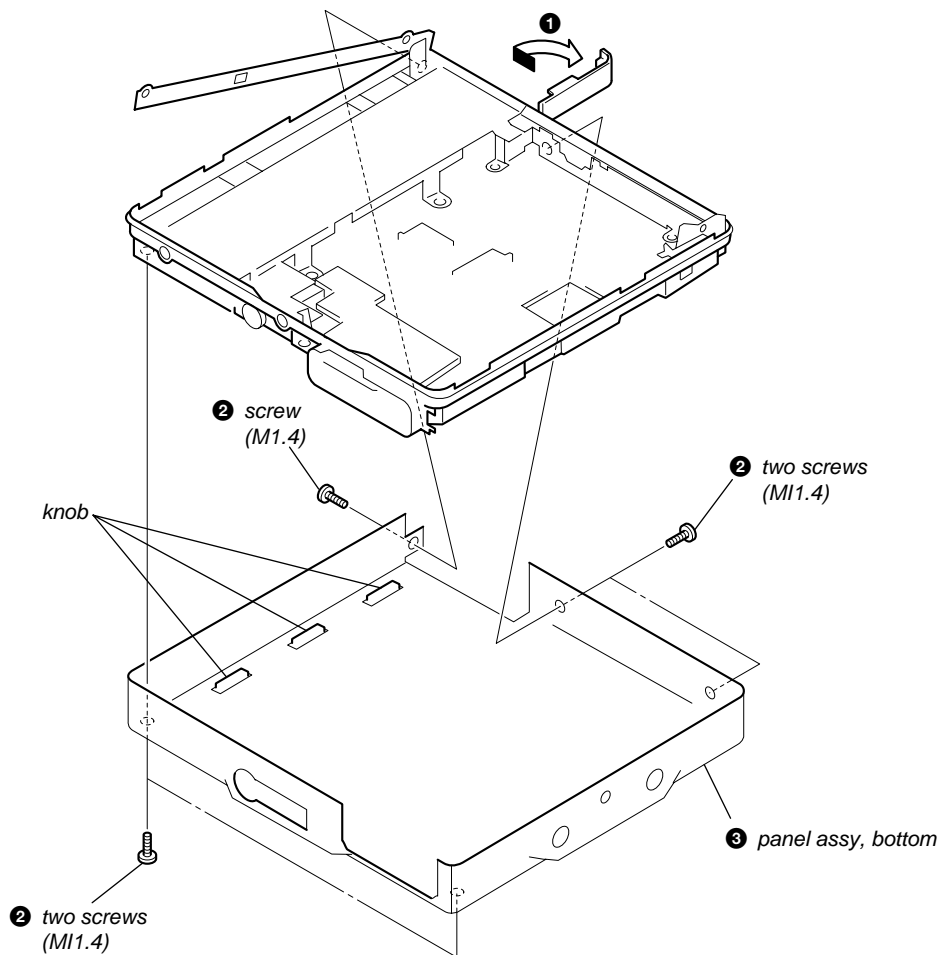

STRIP, ORNAMENTAL

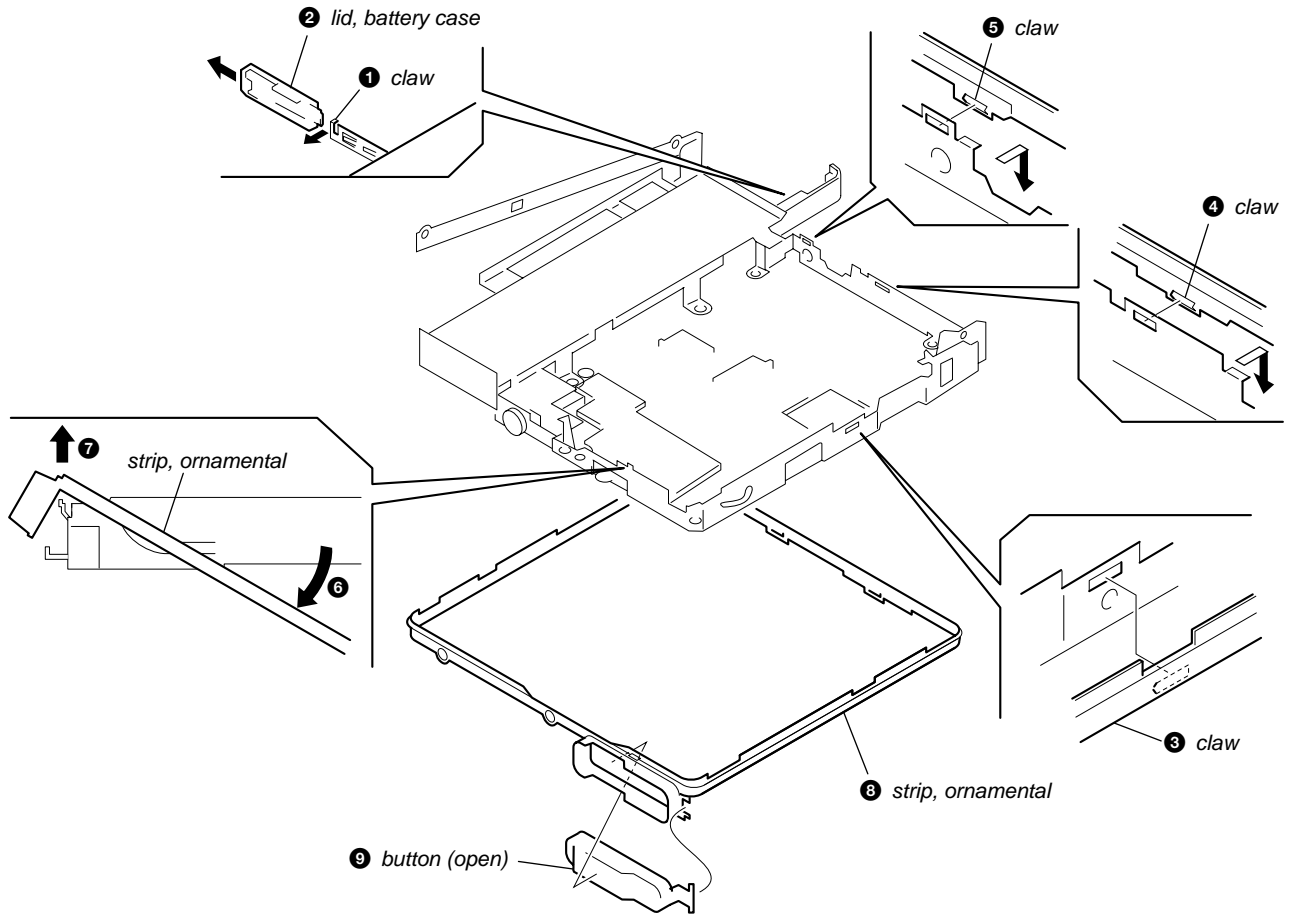

**“CHASSIS ASSY, SET”, “CASE, BATTERY”,
MAIN BOARD, SW BOARD**

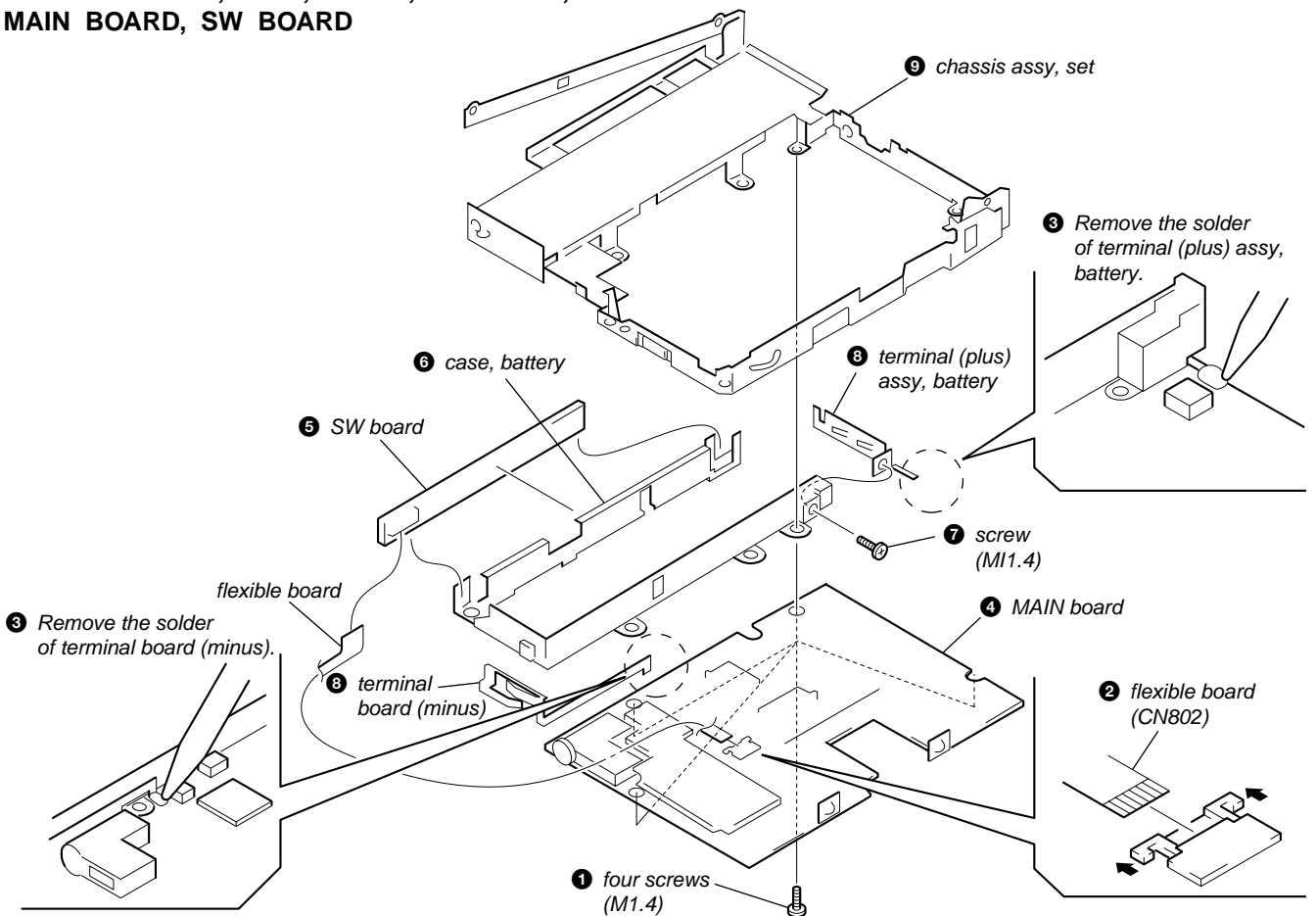

**SERVICE ASSY, OP
(LCX-2E)**

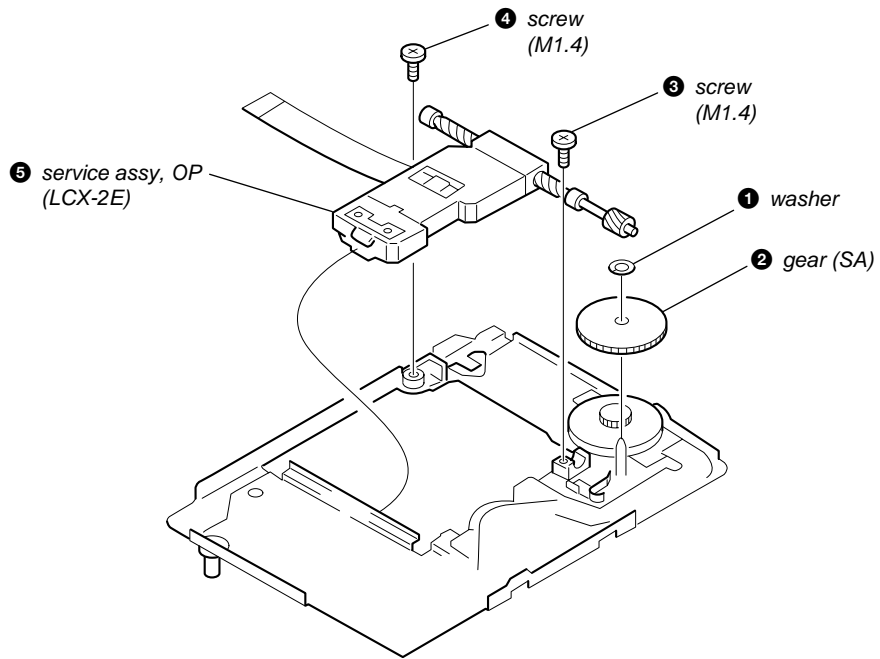

Configuration of Test Mode

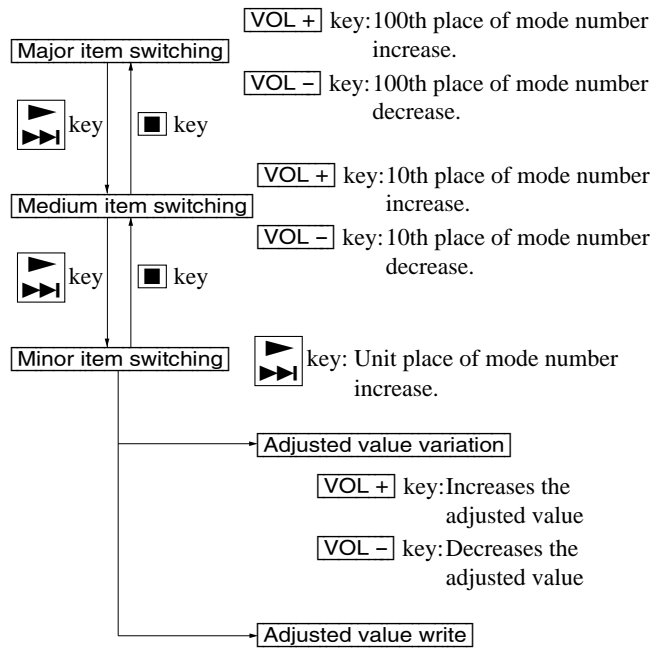
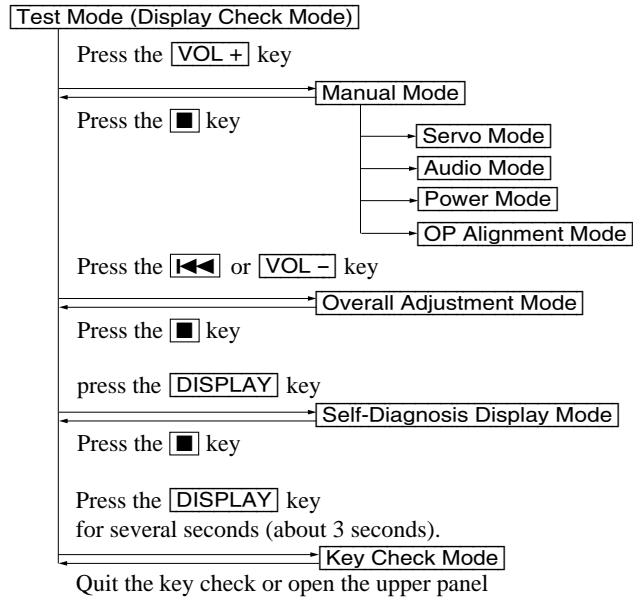

Manual Mode

Mode to adjust or check the operation of the set by function. Normally, the adjustment in this mode is not executed. However, the Manual mode is used to clear the memory before performing automatic adjustments in the Overall Adjustment mode.

• Transition method in Manual Mode

1. Setting the test mode. (See page 9)
2. Press the **[VOL +]** key activates the manual mode where the LCD display as shown below.

LCD display

000 Manual

3. During each test, the optical pick-up moves outward or inward while the **[key]** or **[key]** key is pressed for several seconds respectively.
4. Each test item is assigned with a 3-digit mode number; 100th place is a major item, 10th place is a medium item, and unit place is a minor item.

[key] key: When adjusted value is changed:
Adjusted value is written.
When adjusted value is not changed:
That item is adjusted automatically.

- The display changes as shown below each time the **DISPLAY** key is pressed.

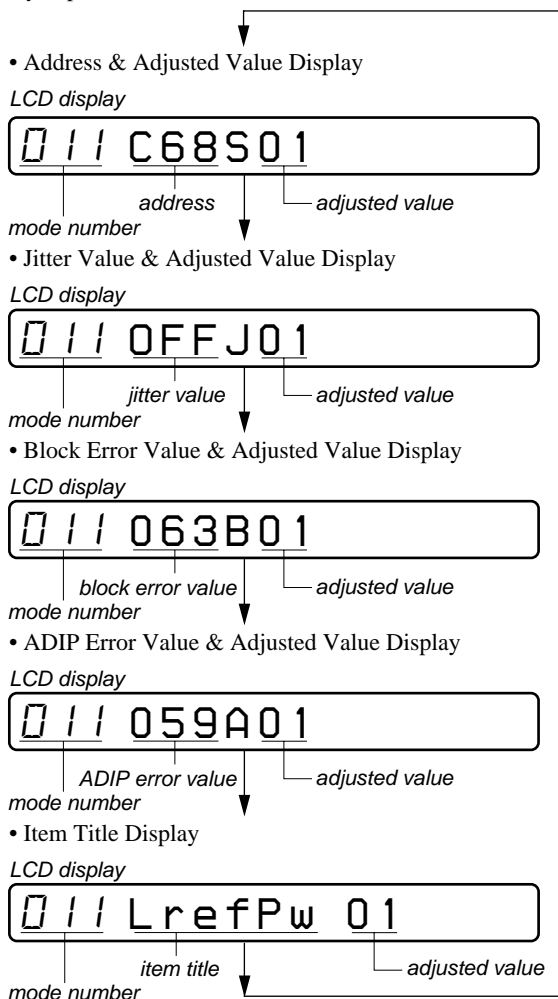

However in the power mode (mode number 700's), only the item is displayed.

- Quit the manual mode, and press the **■** key to return to the test mode (display check mode).

Overall Adjustment Mode

Mode to adjust the servo automatically in all items. Normally, automatic adjustment is executed in this mode at the repair. For further information, refer to "Section 5 Electrical Adjustments". (See page 14)

Self-Diagnosis Display Mode

- This set uses the self-diagnosis system in which if an error occurs in playback mode, the error is detected by the model control and power control blocks of the microprocessor and information on the cause is stored as history in EEPROM. By viewing this history in test mode, it helps you to analyze a fault and determine its location.

- Setting the test mode. (See page 9)
- In the display check mode, press the **DISPLAY** key activates the self-diagnosis display mode where the LCD display as shown below.

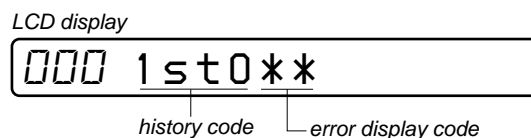

- Then, each time the **▶▶▶** key is pressed, LCD display descends by one as shown below. Also, the LCD display ascends by one when the **◀◀◀** key is pressed.

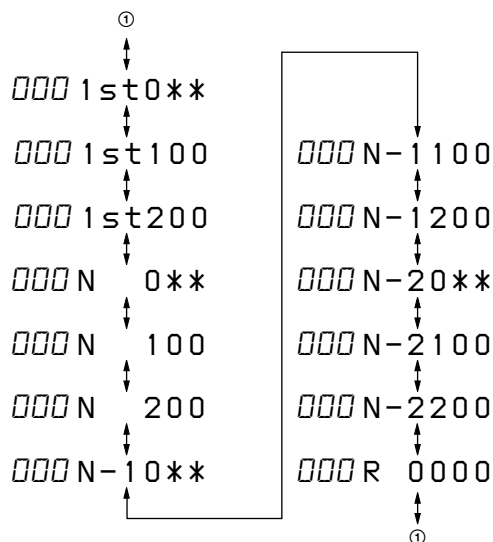

- Quit the self-diagnosis display mode, and press the **■** key to return to the test mode (display check mode).

• **Description of Indication History**

History code number	Description
1st 0	The first error
1st 1	Displays “00”
1st 2	Displays “00”
N 0	The last error
N 1	Displays “00”
N 2	Displays “00”
N-1 0	One error before the last.
N-1 1	Displays “00”
N-1 2	Displays “00”
N-2 0	Two errors before the last.
N-2 1	Displays “00”
N-2 2	Displays “00”
REC	Total recording time (Displays “0000” in this set)

• **Description of Error Indication Codes**

Problem	Indication code	Meaning of code	Description
No error	00	No error	Normal condition
Servo error	01	Illegal access target address was specified	Attempt to access an abnormal address
	02	High temperture	High temperture
	03	Focus error	Forcus could not be applied
	04	Spindle error	Abnormal lotation of disc
Power error	21	Initial low battery	Abnormal voltage at initialization
	22	Low battery	Momentary interruption detected
	23	Low battery NI	Momentary interruption detected (NiMH)
	24	Low battery AM	Momentary interruption detected (AM)

Reset the error display code

After servicing, reset the error display code.

1. Setting the test mode. (See page 9)
2. Press the **[DISPLAY]** key activates the self-diagnosis display mode.
3. To reset the error display code, press the **[II]** key (2 times) when the code is displayed (except “R0000”).
(All the data on the 1st, N, N-1, and N-2 will be reset)

Key Check Mode

This set can check if the set and remote commander function normally.

- Setting Method of Key Check Mode

1. Setting the test mode. (See page 9)
2. Press the **[DISPLAY]** key for several seconds (about 3 seconds) activates the key check mode. (At the last two digits, AD value of remote commander key line is displayed in hexadecimal)

LCD display

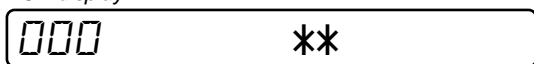

** : AD value of the remote commander key (hexadecimal 00 to FF)

3. When each key on the set and on remote commander is pressed, its name is displayed on the LCD. (The operated position is displayed for 4 seconds after the slide switch is operated. If any other key is pressed during this display, the LCD switches to its name display.)

Example1: When **[▶▶/▶▶]** key on the set is pressed:

LCD display

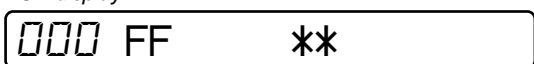

** : AD value of the remote commander key (hexadecimal 00 to FF)

Example2: When **[▶▶▶▶]** key on the remote commander is pressed:

LCD display

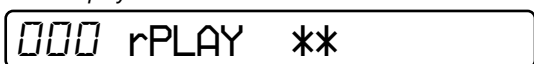

** : AD value of the remote commander key (hexadecimal 00 to FF)

4. When all the keys on the set and on the remote commander are considered as OK, the following displays are shown for 4 seconds.

(The key pressed to enter the Key Check mode has been checked even if it is not pressed in this mode)

Example1: When the keys on the set are considered as OK:

LCD display

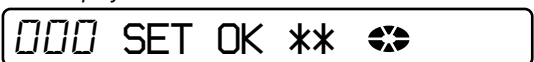

** : AD value of the remote commander key (hexadecimal 00 to FF)

Example2: When the keys on the remote commander are considered as OK:

LCD display

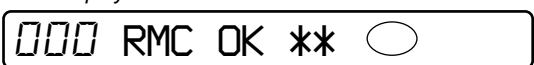

** : AD value of the remote commander key (hexadecimal 00 to FF)

5. When all the key have been checked or when the top panel is opened during this checking, the system terminates the Key Check mode and return to the test mode (display check mode).

• **Adjustment method of Vc PWM Duty (L)**
(item number: 762)

1. Select the manual mode of the test mode, and set the item number 762. (See page 10)

LCD display



2. Connect a digital voltmeter to the TP901 (VC) on the MAIN board, and adjust [VOL +] key (voltage up) or [VOL -] key (voltage down) so that the voltage becomes $2.32^{+0.005}_{-0.01}$ V. Proceed to the next adjustment without pressing the [HOLD] key if voltage is already adjusted.

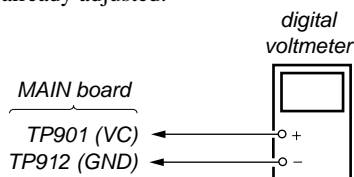

3. Press the [HOLD] key to write the adjusted value.

• **Adjustment method of Vrem PWM Duty (L)**
(item number: 764)

1. Select the manual mode of the test mode, and set the item number 764. (See page 10)

LCD display

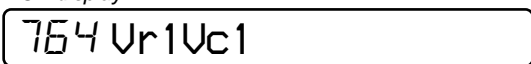

2. Connect a digital voltmeter to the TP903 (VR) on the MAIN board, and adjust [VOL +] key (voltage up) or [VOL -] key (voltage down) so that the voltage becomes $2.25^{+0.005}_{-0.01}$ V. Proceed to the next adjustment without pressing the [HOLD] key if voltage is already adjusted.

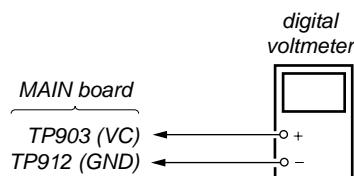

3. Press the [HOLD] key to write the adjusted value.

• **Adjustment method of Vc PWM Duty (H)**
(item number: 765)

1. Select the manual mode of the test mode, and set the item number 765. (See page 10)

LCD display



2. Connect a digital voltmeter to the TP901 (VC) on the MAIN board, and adjust [VOL +] key (voltage up) or [VOL -] key (voltage down) so that the voltage becomes 2.75 ± 0.015 V. Proceed to the next adjustment without pressing the [HOLD] key if voltage is already adjusted.

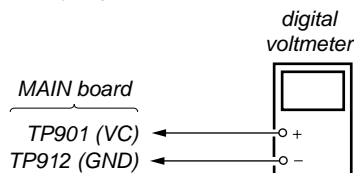

3. Press the [HOLD] key to write the adjusted value.

• **Adjustment method of Vrem PWM Duty (H)**
(item number: 766)

1. Select the manual mode of the test mode, and set the item number 766. (See page 10)

LCD display

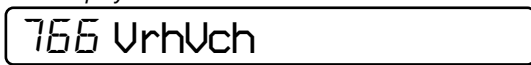

2. Connect a digital voltmeter to the TP903 (VR) on the MAIN board, and adjust [VOL +] key (voltage up) or [VOL -] key (voltage down) so that the voltage becomes 2.6 ± 0.015 V. Proceed to the next adjustment without pressing the [HOLD] key if voltage is already adjusted.

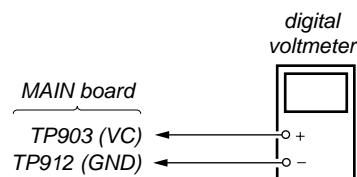

3. Press the [HOLD] key to write the adjusted value.

Adjustment and Connection Location:
– MAIN Board (Component side) –

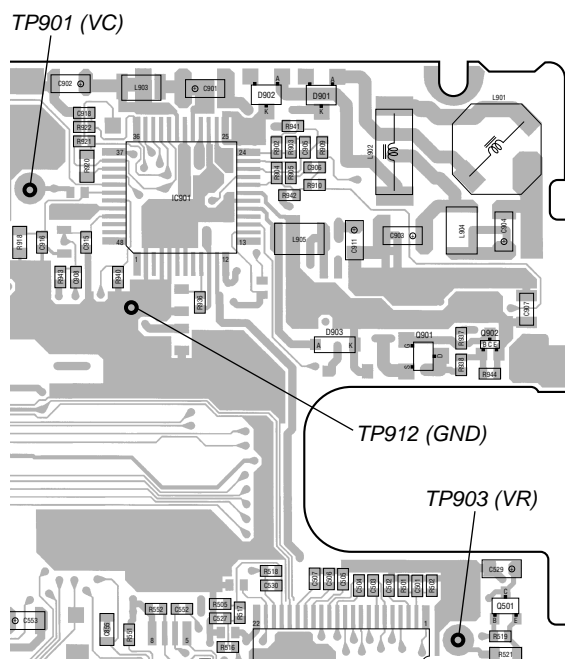

Overall Adjustment Mode

• Configuration of overall adjustment

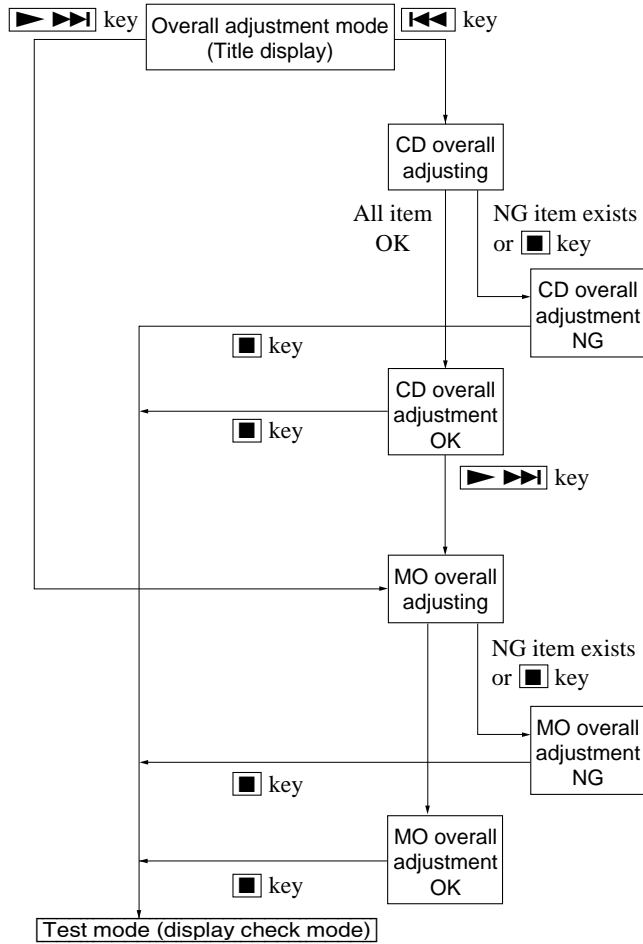

Note: Adjust the CD first, when performing adjustment.

• Adjustment Method of Overall CD and MO Adjustment Mode

1. Setting the test mode. (See page 9)
2. Press the [VOL -] key activates the overall adjustment mode.

LCD display

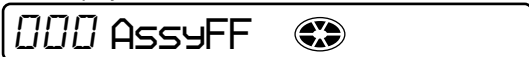

3. Insert CD disc in the set, and press the [key] key to set the Overall CD Adjustment mode. Automatic adjustments are made.

LCD display



XXX: Item number for which an adjustment is being executed.

4. If NG in the overall CD adjustments, return to Reset NV and perform the adjustment again.

LCD display



***: NG item number.

5. If OK through the overall CD adjustments, then perform overall MO adjustments.

LCD display

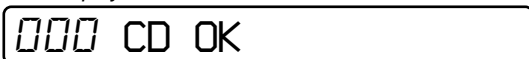

6. Insert MO disc in the set, and press the [key] key to set the Overall MO Adjustment mode. Automatic adjustments are made.

LCD display



XXX: Item number for which an adjustment is being executed.

7. If NG in the overall MO adjustments, return to Reset NV and perform the adjustment again.

LCD display



***: NG item number.

8. If OK through the overall MO adjustments, press the [key] key to return to the test mode and terminate the Overall Adjustment mode.

LCD display

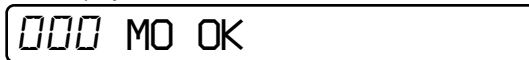

• Overall CD and MO adjustment items

1. Overall CD adjustment items

Item No.	Description
312	CD electrical offset adjustment
313	
314	
328	CD TWPP gain adjustment
321	CD tracking error gain adjustment
323	CD tracking error offset adjustment
332	
336	CD ABCD level adjustment
344	CD focus gain adjustment
345	CD tracking gain adjustment
521	CD two-axis sensitivity adjustment
522	
341	CD focus bias adjustment

2. Overall MO adjustment items

Item No.	Description
112	MO electrical offset adjustment
113	
114	
118	
221	Low reflective CD tracking error gain adjustment
223	Low reflective CD tracking error offset adjustment
232	
236	Low reflective CD ABCD level adjustment
244	Low reflective CD focus gain adjustment
245	Low reflective CD tracking gain adjustment
121	MO tracking error gain adjustment
122	MO tracking error offset adjustment
134	MO TWPP gain adjustment
131	MO double speed read TWPP offset adjustment
132	
136	MO ABCD level adjustment
144	MO focus gain adjustment
145	MO tracking gain adjustment
141	MO focus bias adjustment

6-2. BLOCK DIAGRAM – SERVO Section –

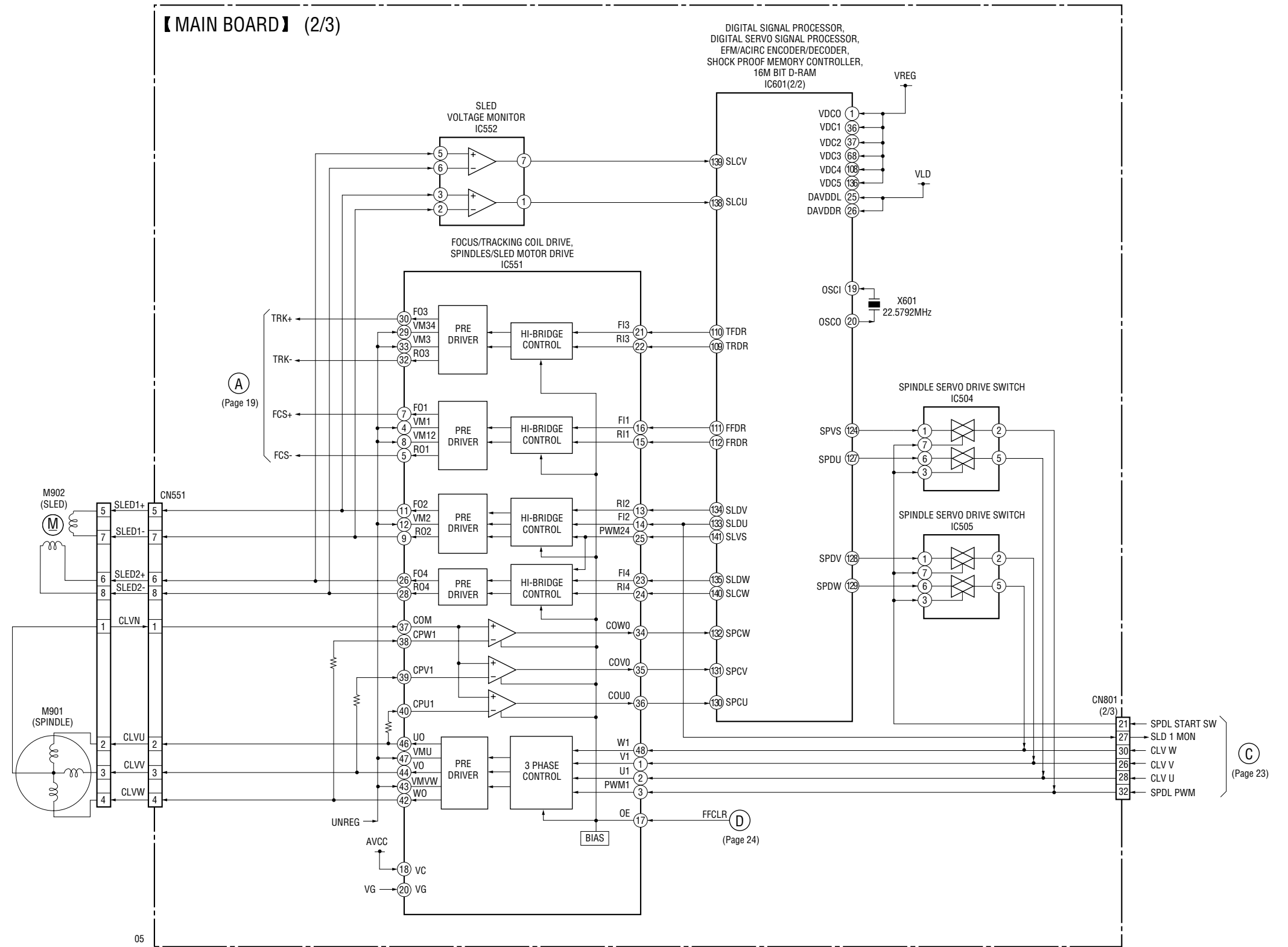

6-3. BLOCK DIAGRAM – MAIN Section –

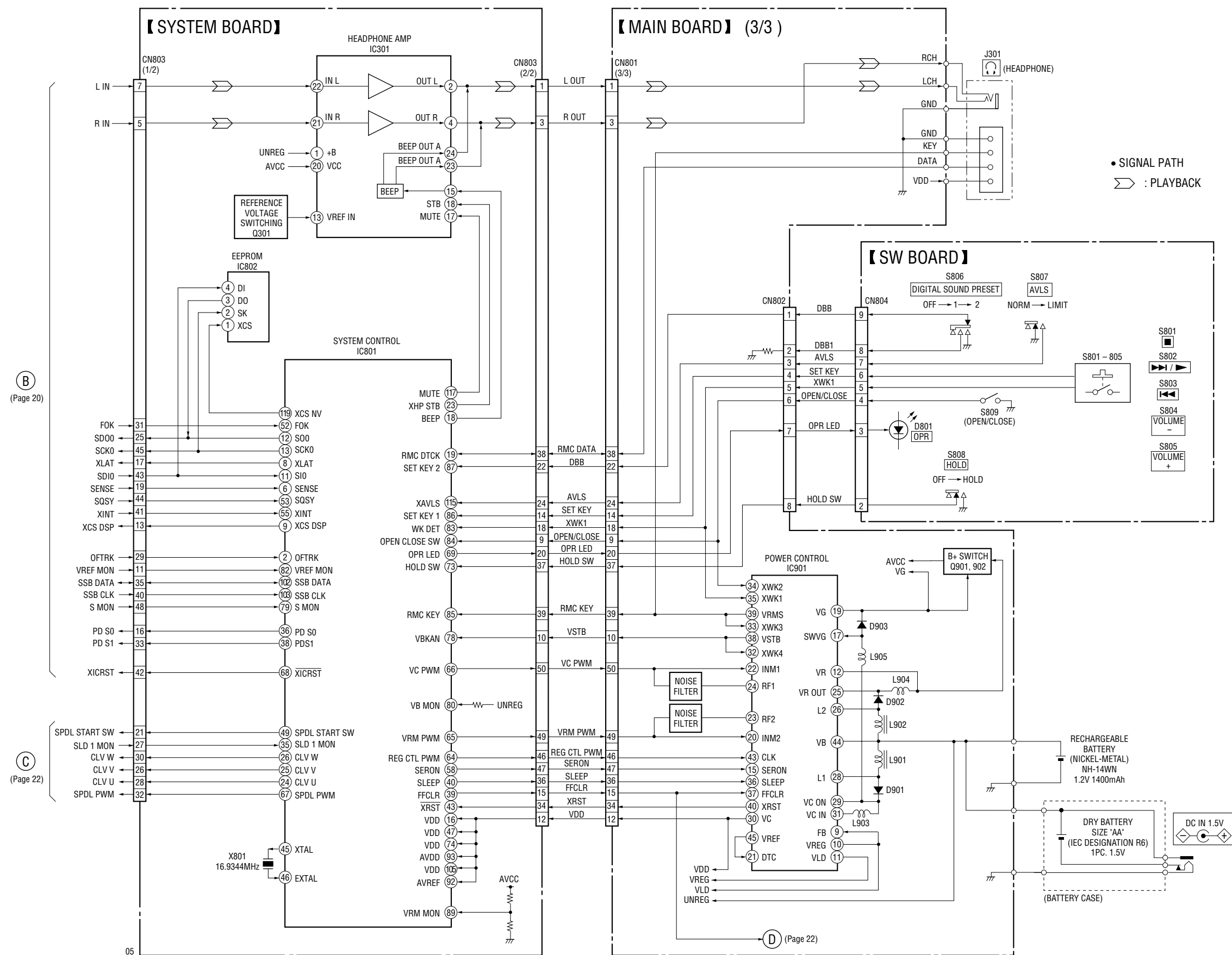

6-5. PRINTED WIRING BOARD – MAIN Board (Conductor Side) –

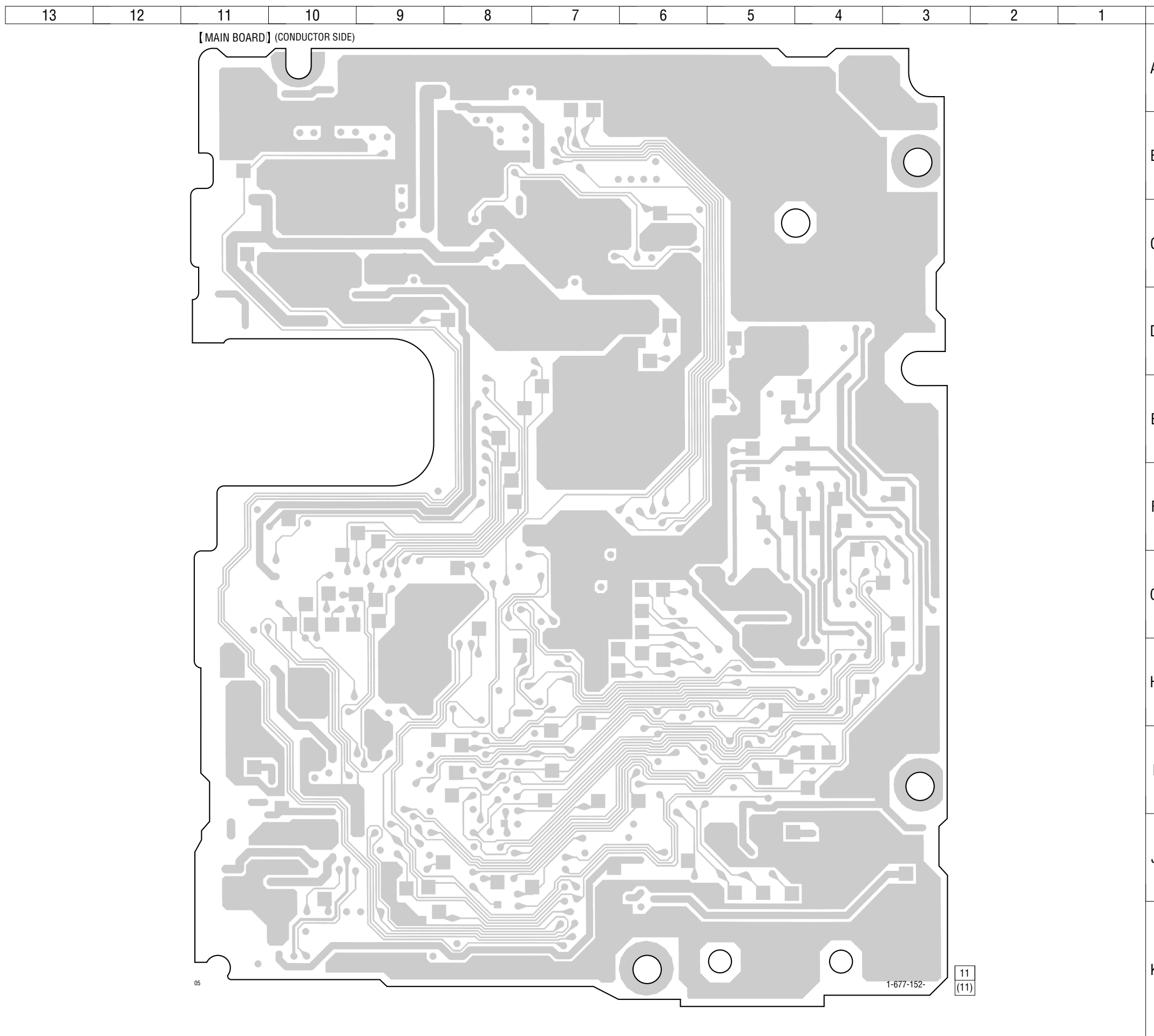

6-6. SCHEMATIC DIAGRAM – MAIN Board (1/4) – • See page 45 for Waveforms. • See page 46 for IC Block Diagram.

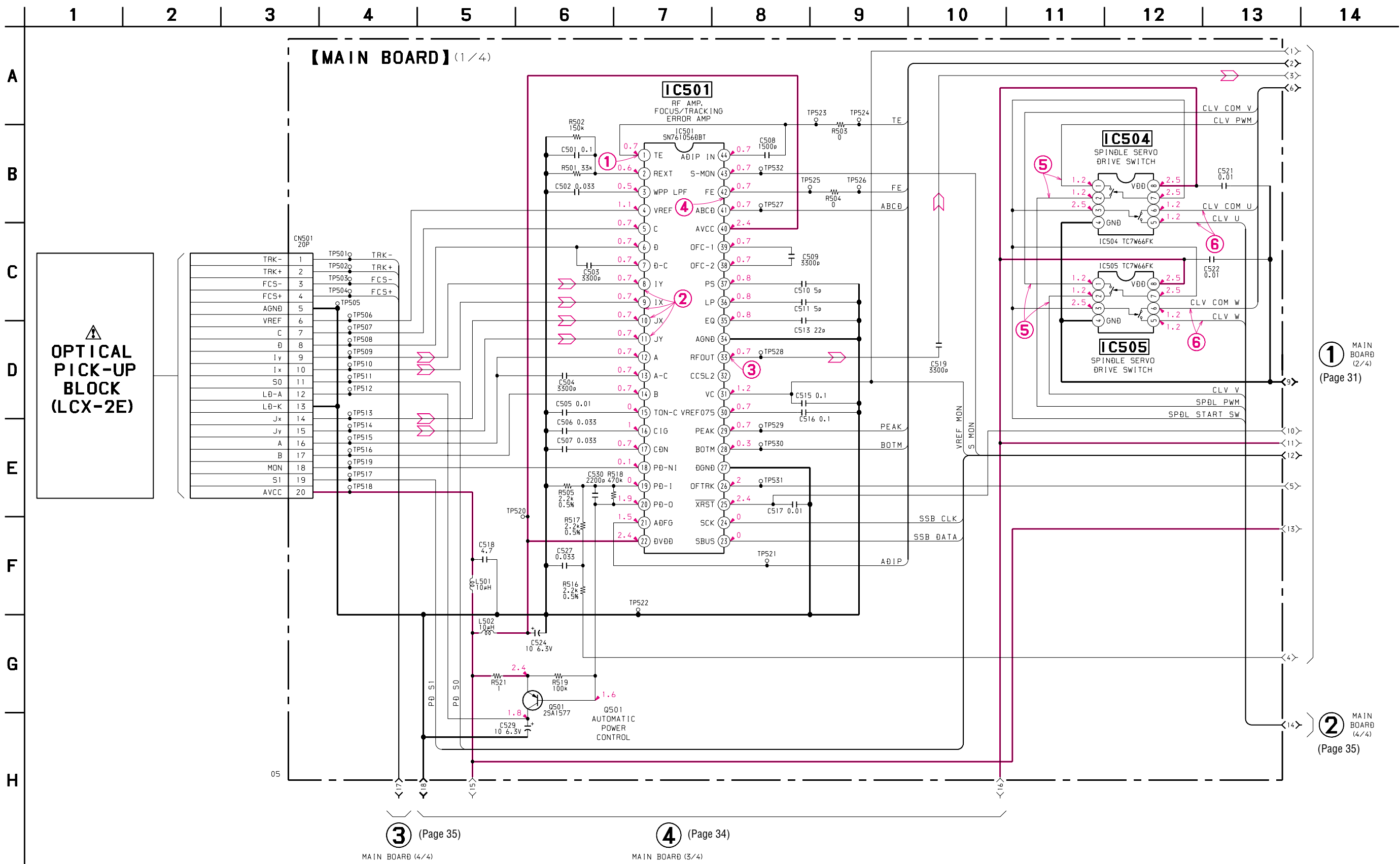

① MAIN BOARD (2/4) (Page 31)

② MAIN BOARD (4/4) (Page 35)

③ (Page 35)

④ (Page 34)

Note on Schematic Diagram:

- All capacitors are in μF unless otherwise noted. pF : μpF 50 WV or less are not indicated except for electrolytics and tantalums.
- All resistors are in Ω and $1/4\text{W}$ or less unless otherwise specified.
- % : indicates tolerance.
- — : B+ Line.
- Power voltage is dc 1.5V and fed with regulated dc power supply from battery terminal.

- Voltages and waveforms are dc with respect to ground in playback mode.
- no mark : PLAYBACK
- Voltages are taken with a VOM (Input impedance 10 $\text{M}\Omega$). Voltage variations may be noted due to normal production tolerances.
- Waveforms are taken with an oscilloscope. Voltage variations may be noted due to normal production tolerances.

- Circled numbers refer to waveforms.
- Signal path.
- \Rightarrow : PLAYBACK

Note: The components identified by mark Δ or dotted line with mark Δ are critical for safety. Replace only with part number specified.

6-7. SCHEMATIC DIAGRAM – MAIN Board (2/4) – • See page 45 for Waveforms.

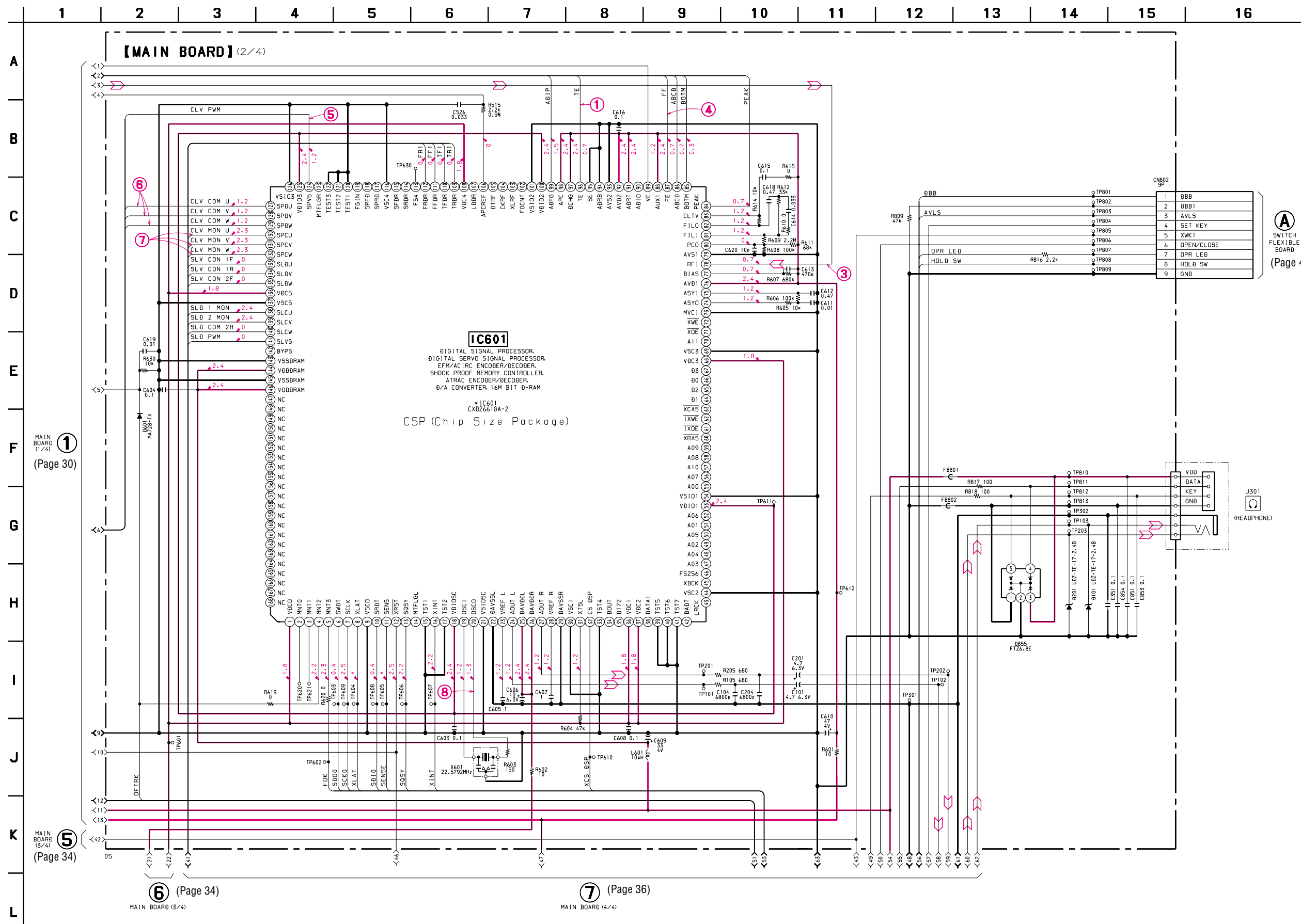

Note on Schematic Diagram:

- All capacitors are in μF unless otherwise noted. pF : μpF 50 WV or less are not indicated except for electrolytics and tantalums.
- All resistors are in Ω and $1/4\text{W}$ or less unless otherwise specified.
- % : indicates tolerance.
- Δ : internal component.
- : panel designation.

- — : B+ Line.
- Power voltage is dc 1.5V and fed with regulated dc power supply from battery terminal.
- Voltages and waveforms are dc with respect to ground in playback mode.
 no mark : PLAYBACK
 * : Impossible to measure

- Voltages are taken with a VOM (Input impedance 10 M Ω). Voltage variations may be noted due to normal production tolerances.
- Waveforms are taken with an oscilloscope. Voltage variations may be noted due to normal production tolerances.
- Circled numbers refer to waveforms.

- Signal path.
↻ : PLAYBACK

* IC601 is not replaceable

- The voltage and waveform of CSP (chip size package) cannot be measured, because its lead layout is different form that of conventional IC.

6-8. SCHEMATIC DIAGRAM – MAIN Board (3/4) – • See page 45 for Waveform. • See page 48 for IC Block Diagram.

1 2 3 4 5 6 7 8 9 10 11 12 13 14

- Note on Schematic Diagram:**
- All capacitors are in μF unless otherwise noted. pF: μpF
 - 50 WV or less are not indicated except for electrolytics and tantalums.
 - All resistors are in Ω and $1/4\text{ W}$ or less unless otherwise specified.
 - % : indicates tolerance.
 - **—** : B+ Line.
 - Power voltage is dc 1.5V and fed with regulated dc power supply from battery terminal.
 - Voltages and waveform are dc with respect to ground in playback mode.
no mark : PLAYBACK
 - Voltages are taken with a VOM (Input impedance 10 M Ω).
Voltage variations may be noted due to normal production tolerances.
 - Waveform is taken with a oscilloscope.
Voltage variations may be noted due to normal production tolerances.
 - Circled number refers to waveform.

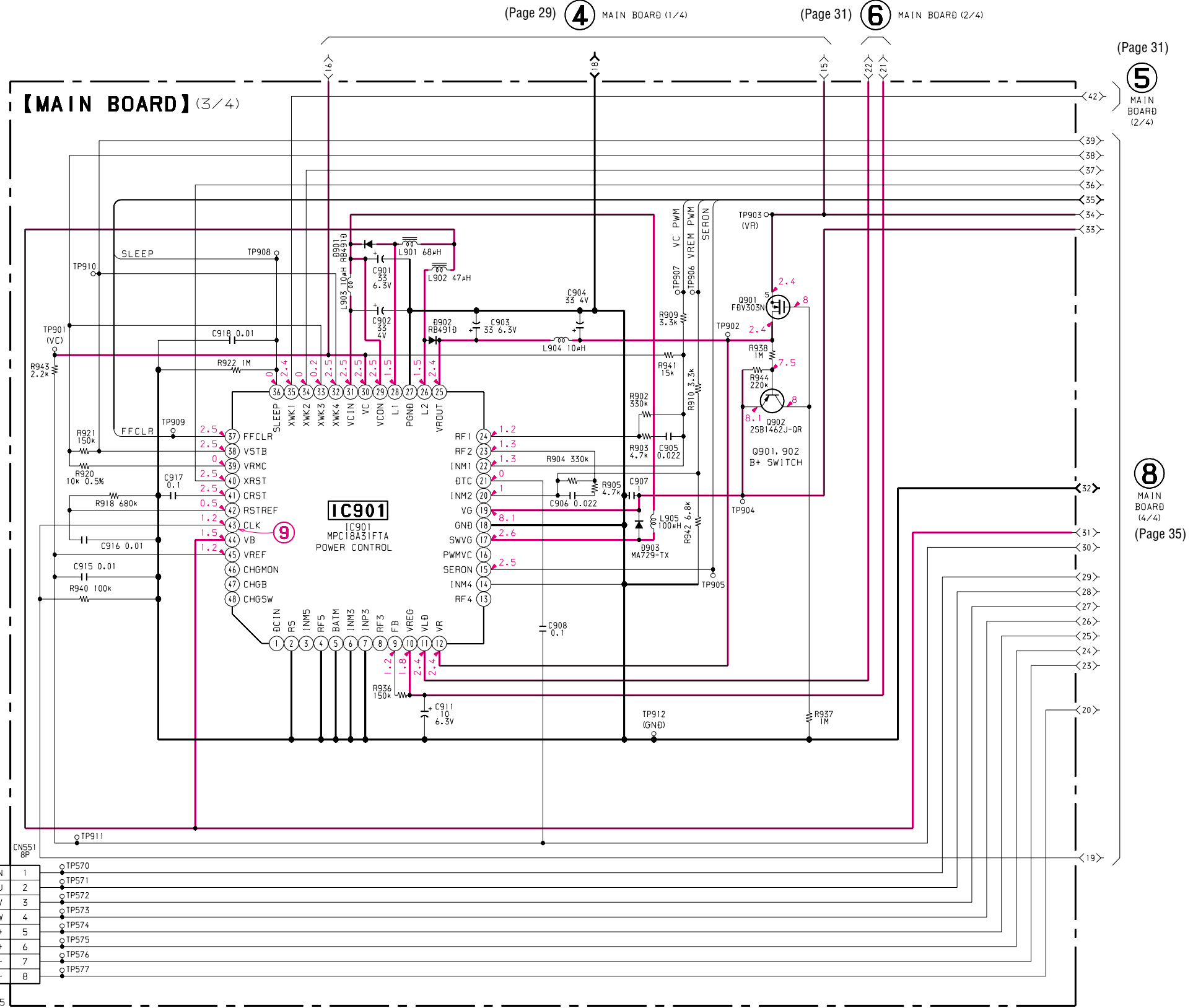

A
B
C
D
E
F
G
H
I

(Page 29) **4** MAIN BOARD (1/4)

(Page 31) **6** MAIN BOARD (2/4)

(Page 31) **5** MAIN BOARD (2/4)

8 MAIN BOARD (4/4) (Page 35)

6-9. SCHEMATIC DIAGRAM – MAIN Board (4/4) – • See page 45 for Waveforms. • See page 47 for IC Block Diagram.

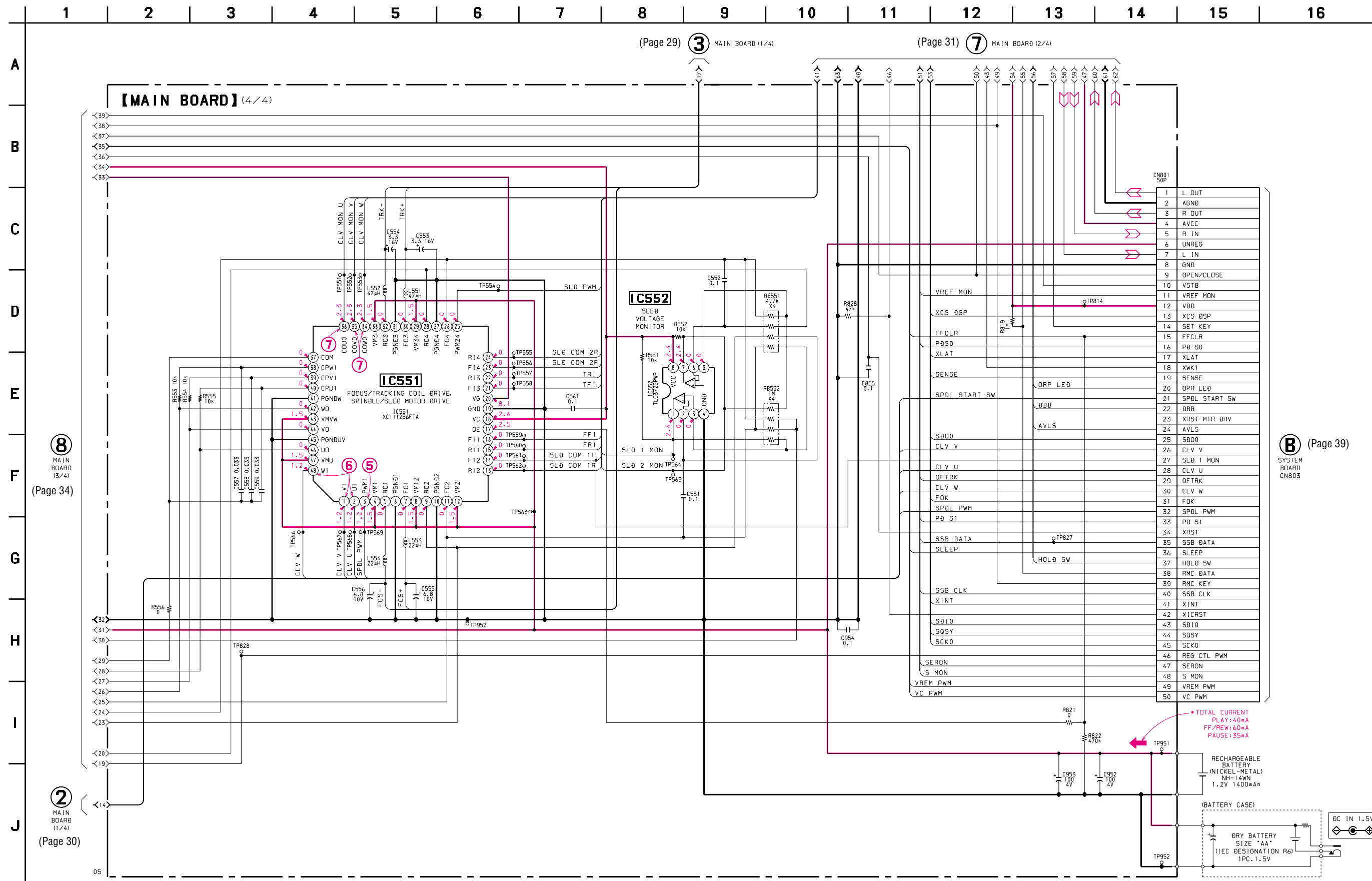

Note on Schematic Diagram:

- All capacitors are in μF unless otherwise noted. pF : μpF
- 50 WV or less are not indicated except for electrolytics and tantalums.
- All resistors are in Ω and $1/4\text{W}$ or less unless otherwise specified.
- : panel designation.
- —: B+ Line.
- Total current is measured with MD installed.

- Power voltage is dc 1.5V and fed with regulated dc power supply from battery terminal.
- Voltages and waveforms are dc with respect to ground in playback mode.
- Voltages are taken with a VOM (Input impedance 10 M Ω). Voltage variations may be noted due to normal production tolerances.

- Waveforms are taken with an oscilloscope. Voltage variations may be noted due to normal production tolerances.
- Circled numbers refer to waveforms.
- Signal path.
- ▷: PLAYBACK

6-10. PRINTED WIRING BOARD – SYSTEM Board –

• Semiconductor Location

Ref. No.	Location
IC301	F-3
IC801	F-6
IC802	F-8
Q301	G-3

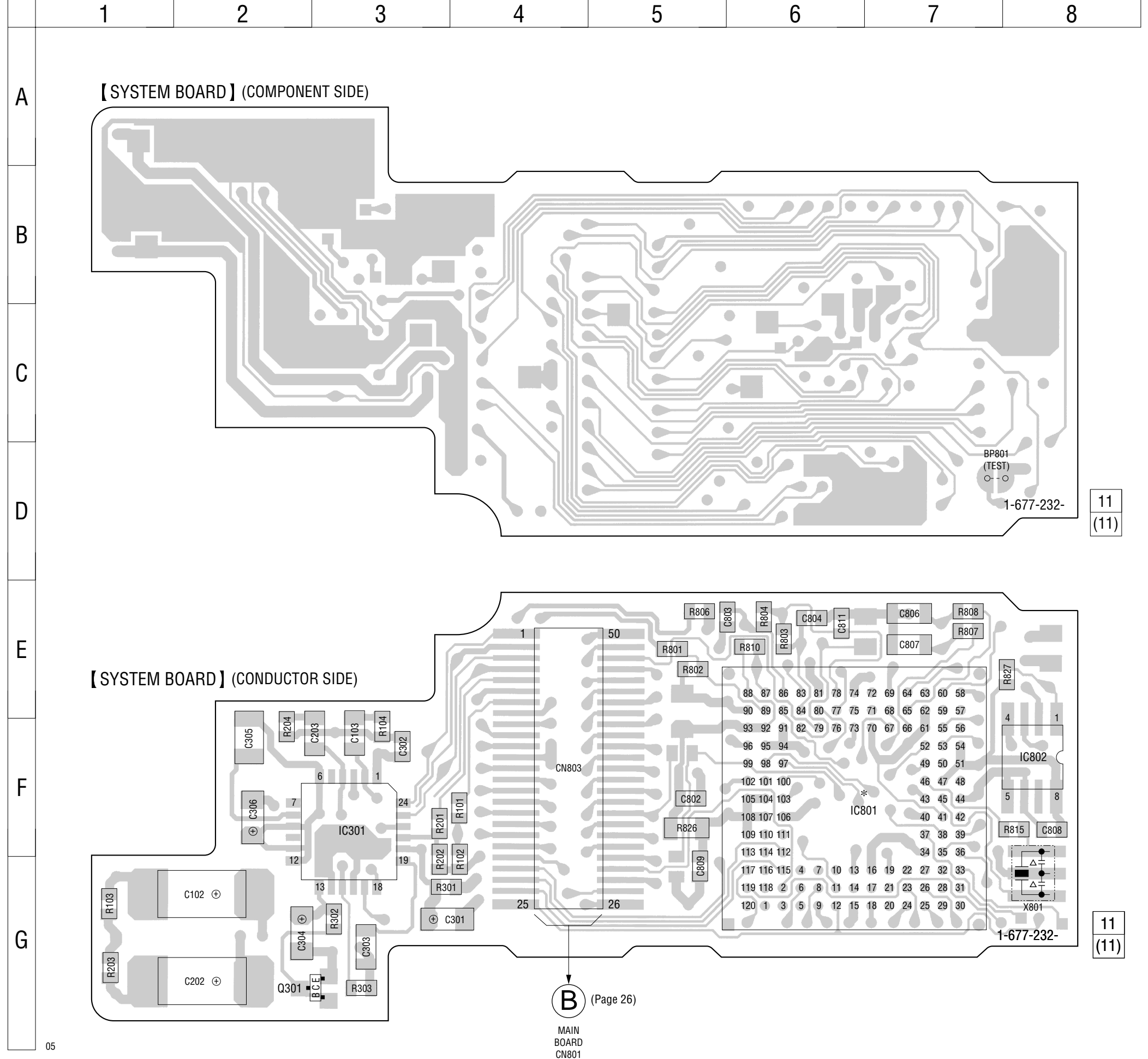

Note on Printed Wiring Board:

- — : parts extracted from the conductor side.
- Δ : internal component.
- [Pattern] : Pattern from the side which enables seeing. (The other layers' patterns are not indicated.)

Caution:
 Pattern face side: Parts on the pattern face side seen from the pattern face are indicated.
 Parts face side: Parts on the parts face side seen from the parts face are indicated.

• System board is four-layer printed board. However, the patterns of layers 2 and 3 have not been included in this diagrams.

* IC801 is not replaceable

• Lead Layouts

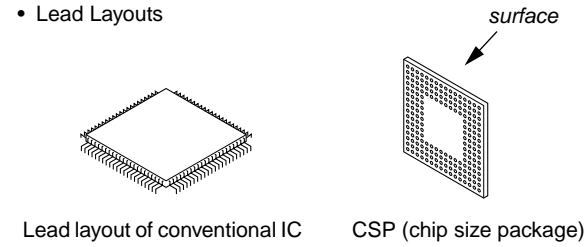

6-11. SCHEMATIC DIAGRAM – SYSTEM Board – • See page 45 for Waveforms. • See page 48 for IC Block Diagram.

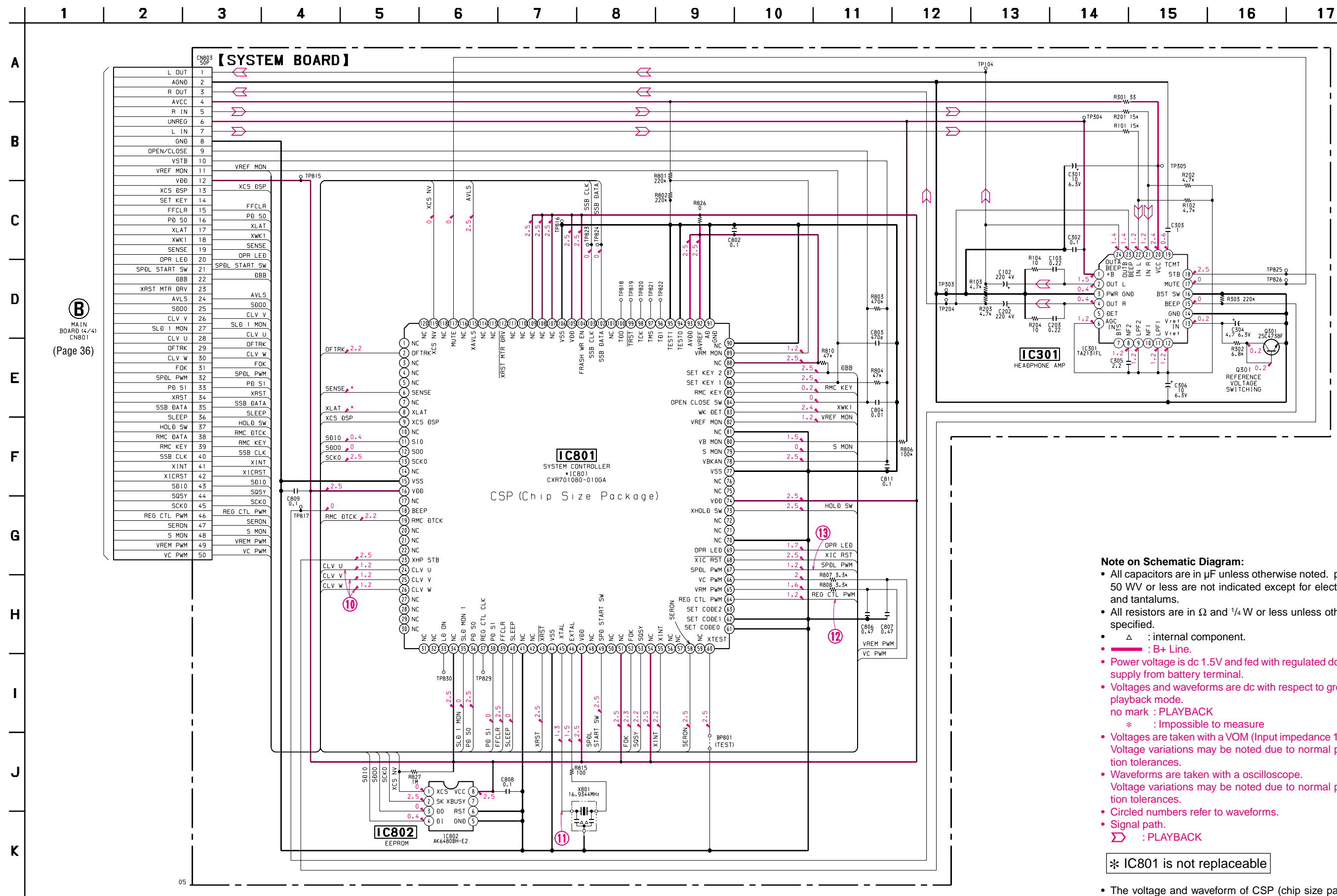

B
MAIN BOARD (4/4)
CN801
(Page 36)

- Note on Schematic Diagram:**
- All capacitors are in μF unless otherwise noted. pF : μF 50 WV or less are not indicated except for electrolytics and tantalums.
 - All resistors are in Ω and $1/4\text{ W}$ or less unless otherwise specified.
 - Δ : internal component.
 - --- : B+ Line.
 - Power voltage is dc 1.5V and fed with regulated dc power supply from battery terminal.
 - Voltages and waveforms are dc with respect to ground in playback mode.
 - no mark : PLAYBACK
 - * : Impossible to measure
 - Voltages are taken with a VOM (Input impedance 10 M Ω). Voltage variations may be noted due to normal production tolerances.
 - Waveforms are taken with an oscilloscope. Voltage variations may be noted due to normal production tolerances.
 - Circled numbers refer to waveforms.
 - Signal path.
 - --- : PLAYBACK

* IC801 is not replaceable

The voltage and waveform of CSP (chip size package) cannot be measured, because its lead layout is different from that of conventional IC.

6-12. PRINTED WIRING BOARD – SW Board –

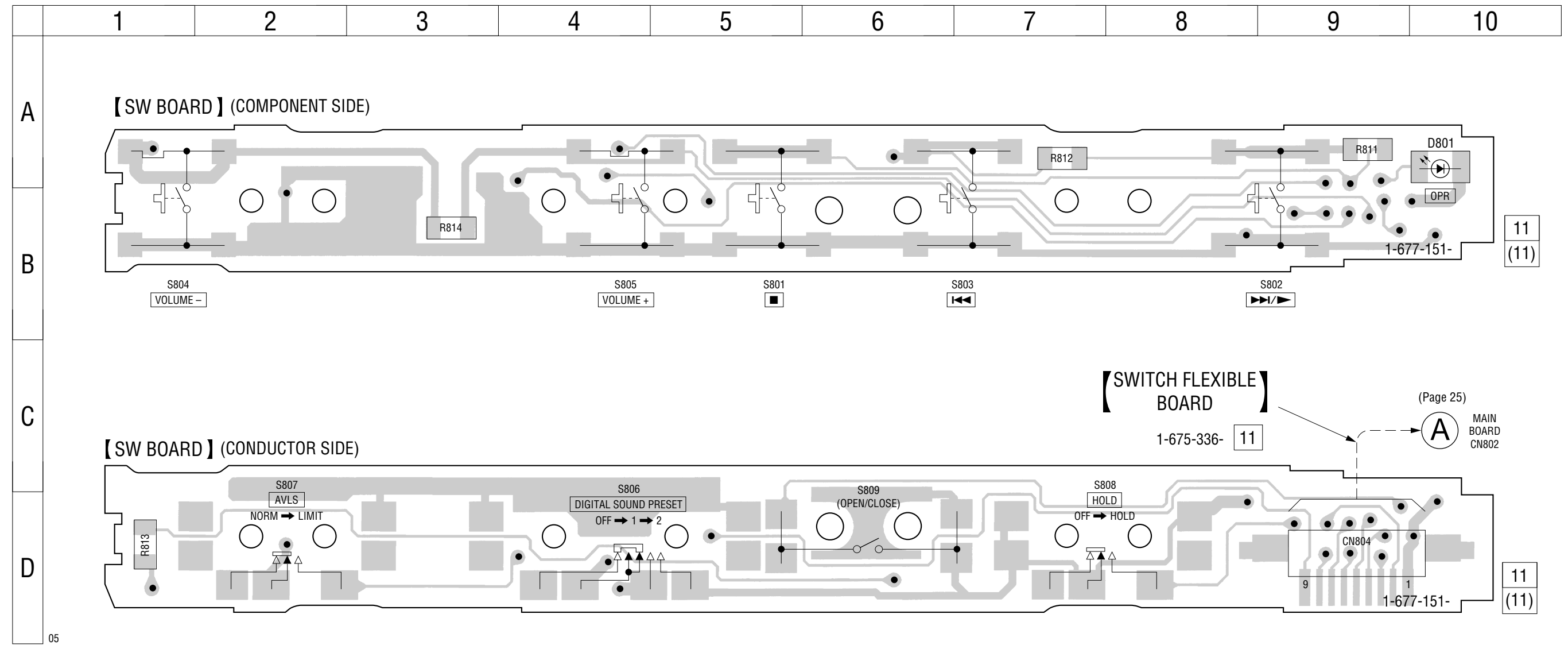

Note on Printed Wiring Board:
 • — : parts extracted from the conductor side.
 • ● : Through hole.
 (The other layers' patterns are not indicated.)

Caution:
 Pattern face side: Parts on the pattern face side seen from the pattern face are indicated.
 (Conductor Side)
 Parts face side: Parts on the parts face side seen from the parts face are indicated.
 (Component Side)

6-13. SCHEMATIC DIAGRAM – SW Board –

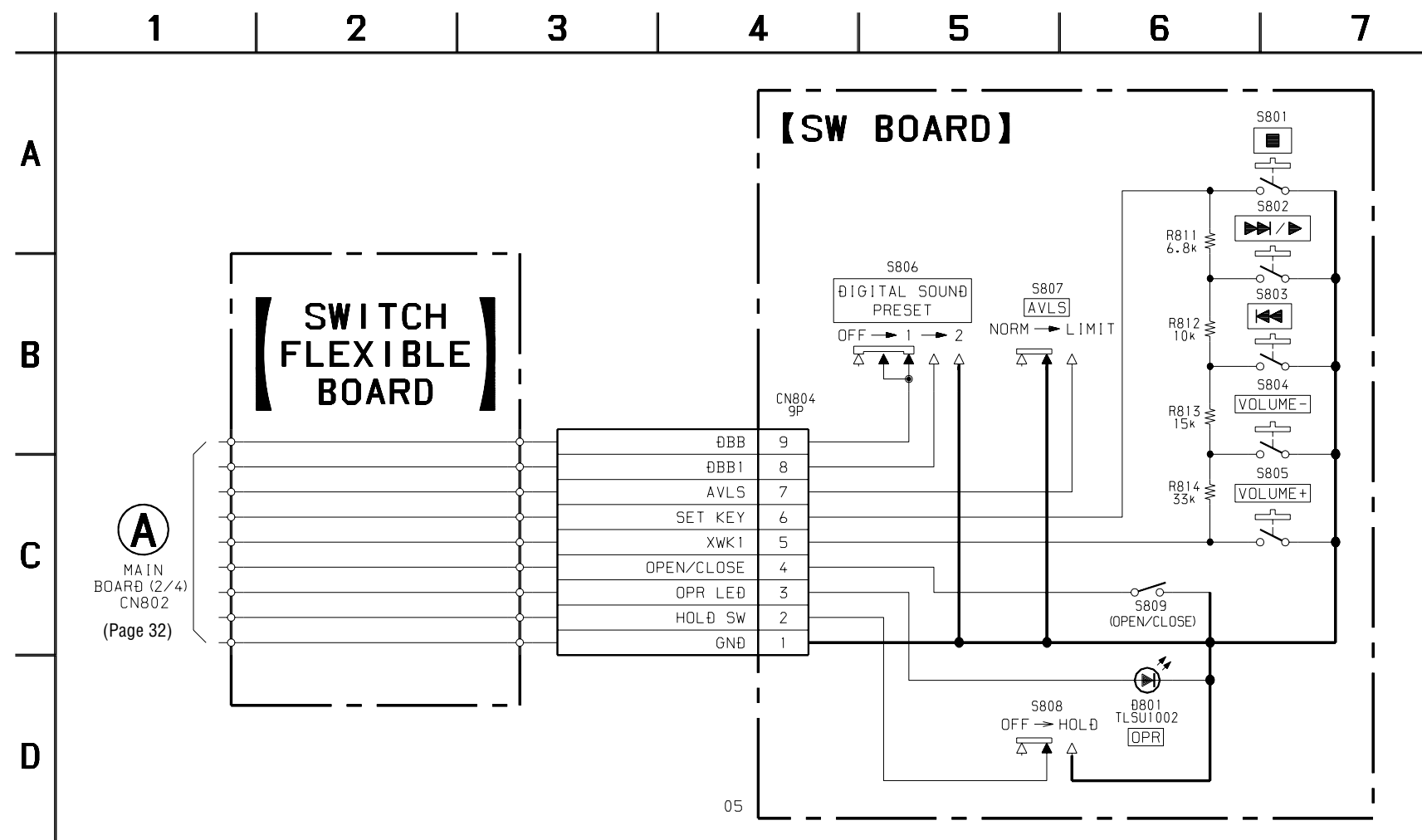

Note on Schematic Diagram:

- All capacitors are in μF unless otherwise noted. pF: $\mu\mu\text{F}$ 50 WV or less are not indicated except for electrolytics and tantalums.
- All resistors are in Ω and $\frac{1}{4}\text{W}$ or less unless otherwise specified.
- : panel designation.

• Waveforms
– MAIN Board –

1 IC501 ① (TE), IC601 ⑩ (TE)
(PLAYBACK mode)
100 mV/DIV, 1 μ s/DIV

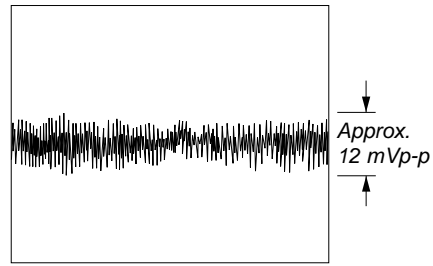

2 IC501 ⑧, ⑨, ⑩, ⑪ (IY, IX, JX, JY)
(PLAYBACK mode)
100 mV/DIV, 5 μ s/DIV

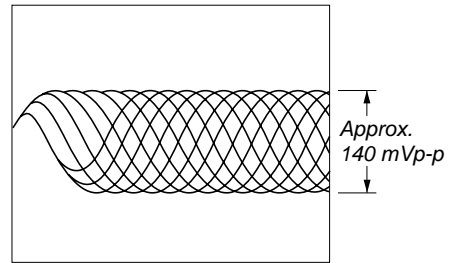

3 IC501 ⑬ (RF OUT),
IC601 ⑰ (RFI) (PLAYBACK mode)
500 mV/DIV, 10 μ s/DIV

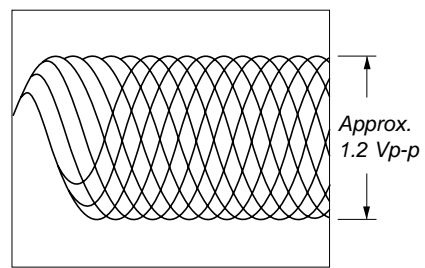

4 IC501 ④ (FE),
IC601 ⑥ (FE) (PLAYBACK mode)
100 mV/DIV, 1 μ s/DIV

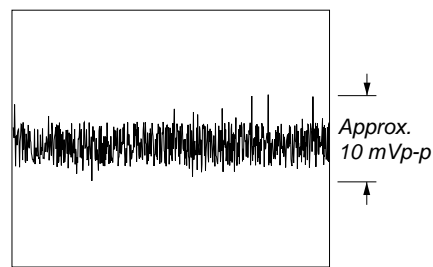

5 IC504 ①, ②, IC551 ③ (PWM1),
IC601 ④ (SPVS) (PLAYBACK mode)
1 V/DIV, 2 μ s/DIV

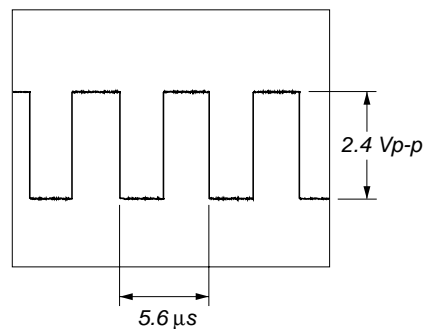

6 IC504 ⑤, ⑥, IC505 ①, ②, ⑤, ⑥,
IC551 ①, ②, ④ (V1, U1, W1)
IC601 ⑫, ⑬, ⑭ (SPDU, SPDV, SPDW)
(PLAYBACK mode)
1 V/DIV, 5 ms/DIV

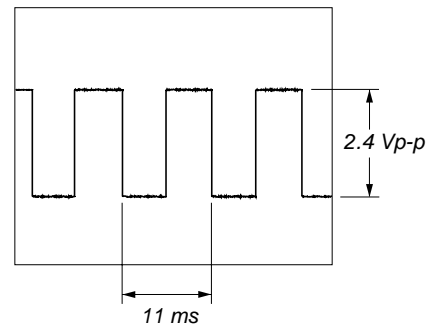

7 IC551 ⑳, ㉑, ㉒ (COW0, COV0, COU0)
IC601 ⑮, ⑯, ㉓ (SPCU, SPCV, SPCW)
(PLAYBACK mode)
1 V/DIV, 5 ms/DIV

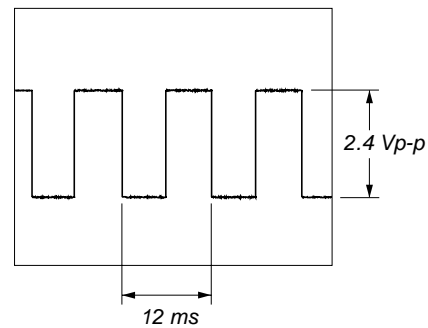

8 IC601 ⑲ (OSCO)
500 mV/DIV, 20 ns/DIV

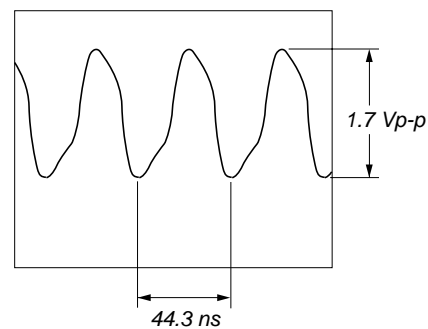

9 IC901 ④ (CLK)
1 V/DIV, 2 μ s/DIV

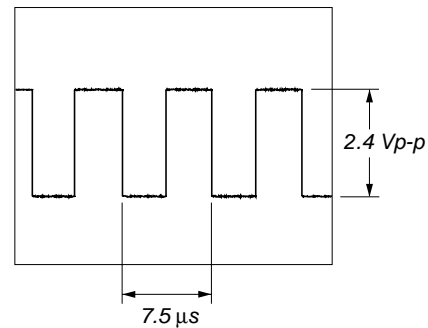

– SYSTEM Board –

10 IC801 ㉔, ㉕, ㉖ (CLV U, CLV V, CLV W)
(PLAYBACK mode)
1 V/DIV, 5 ms/DIV

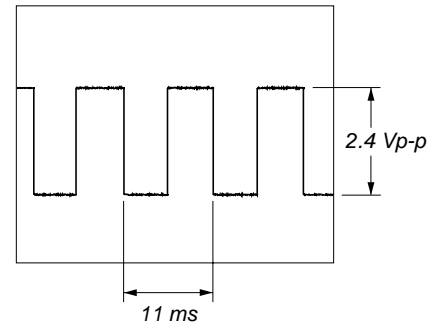

11 IC801 ④ (XTAL)
1 V/DIV, 20 ns/DIV

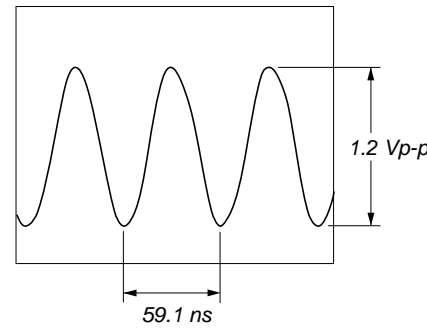

12 IC801 ⑥ (REG CTL PWM)
1 V/DIV, 2 μ s/DIV

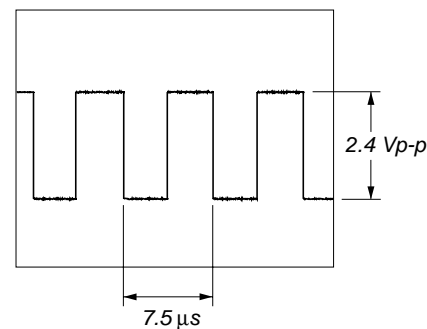

13 IC801 ⑦ (SPDL PWM)
(PLAYBACK mode)
1 V/DIV, 2 μ s/DIV

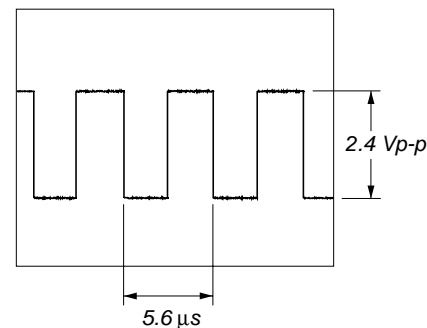

• IC Block Diagrams
– MAIN Board –

IC501 SN761056DBT

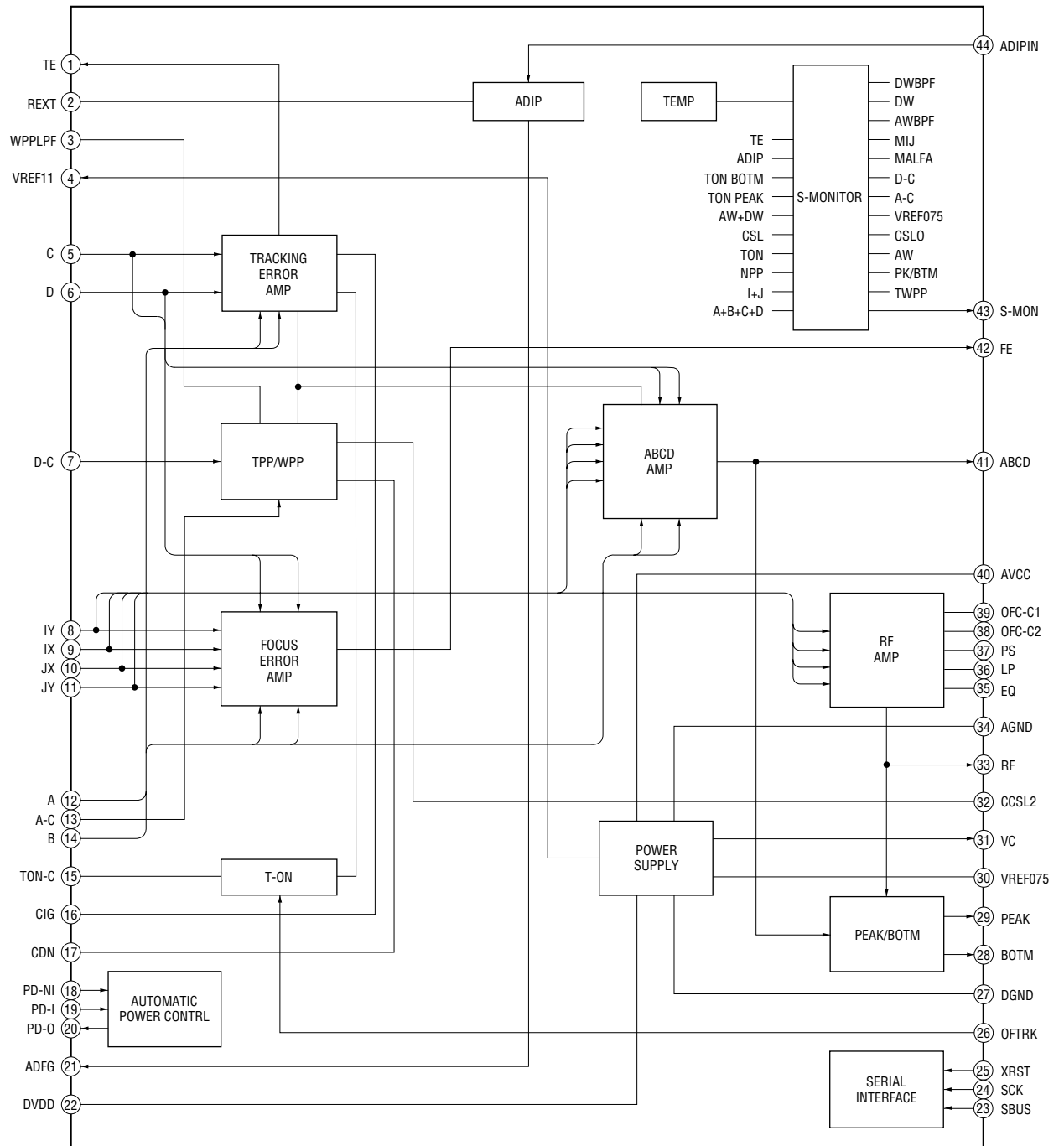

IC551 XC111256FTA

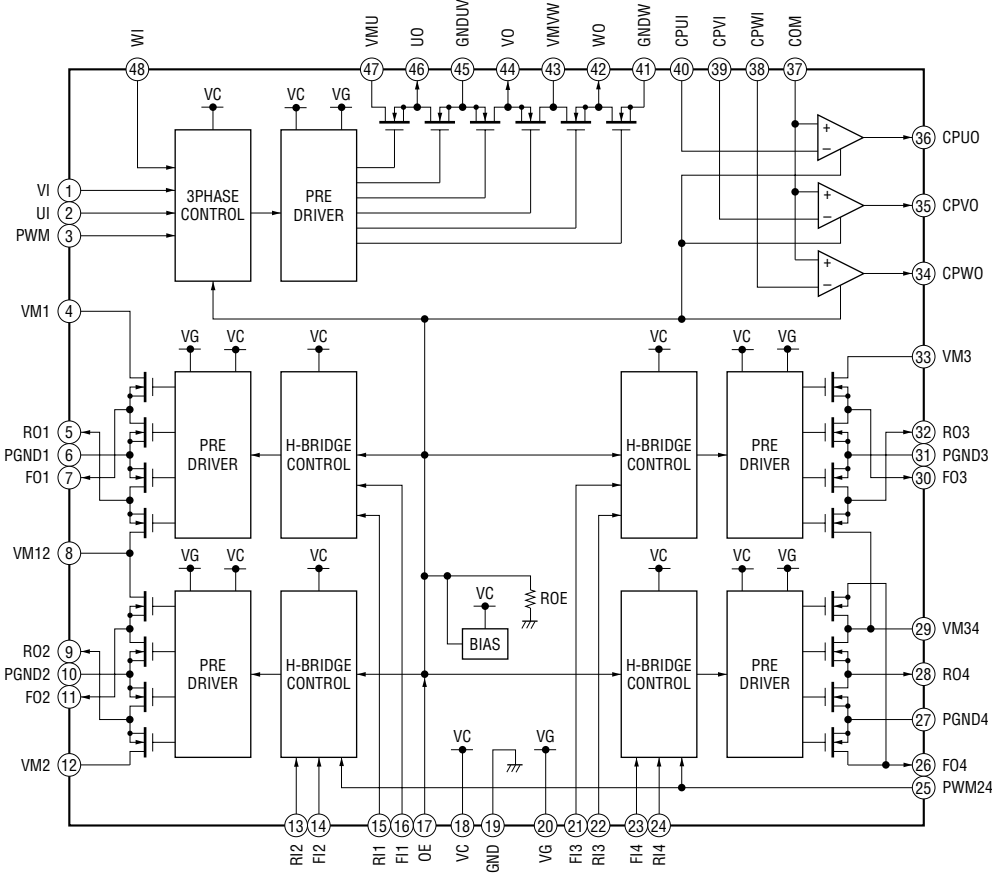

IC901 MPC18A31FTA

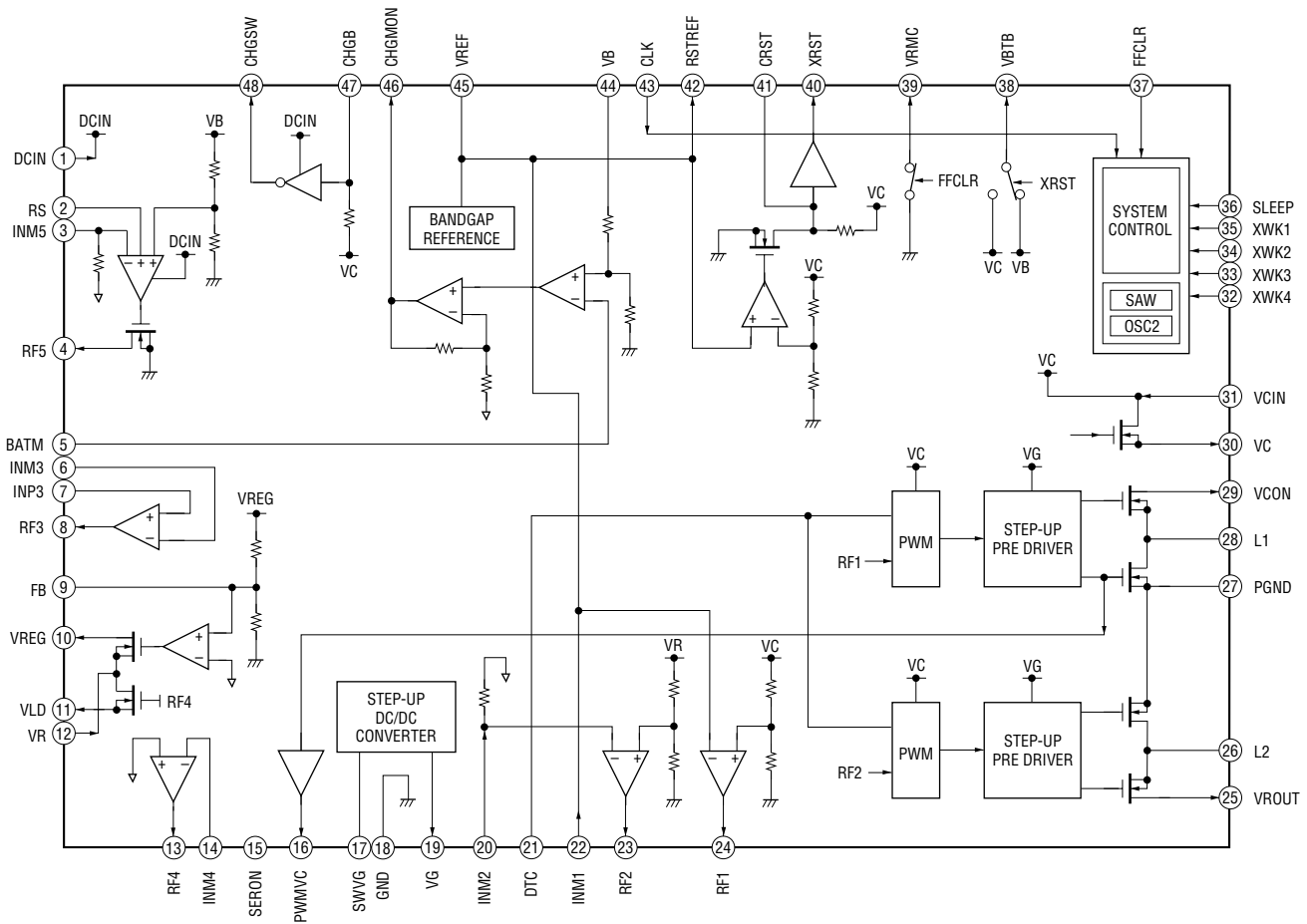

- SYSTEM Board -

IC301 TA2131FL (EL)

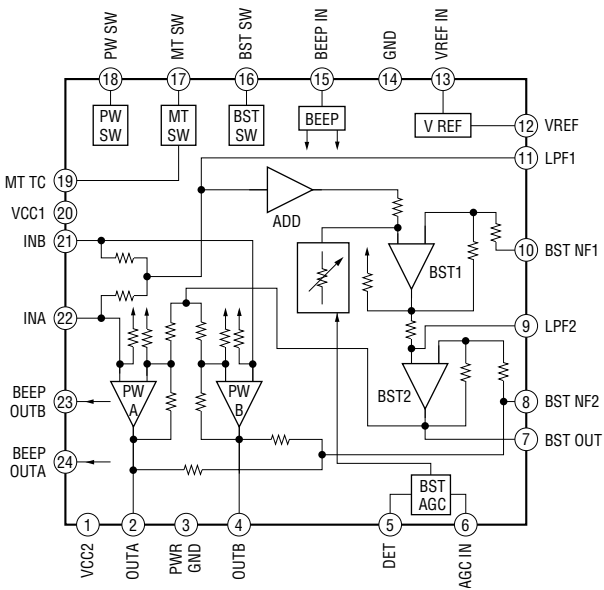

6-14. IC PIN FUNCTION DESCRIPTION

• MAIN BOARD IC501 SN761056DBT (RF AMP, FOCUS/TRACKING ERROR AMP)

Pin No.	Pin Name	I/O	Description
1	TE	O	Tracking error signal output to the CXD2661GA (IC601)
2	REXT	—	Connected to the external resistor for the ADIP amplifier control
3	WPPLPF	—	Connected to the external capacitor for low-pass filter of the TPP/WPP
4	VREF11	O	Reference voltage output terminal (+1.1V)
5	C	I	Signal (C) input from the optical pick-up detector
6	D	I	Signal (D) input from the optical pick-up detector
7	D-C	I	Signal (D) input from the optical pick-up detector (AC input)
8	IY	I	I-V converted RF signal (IY) input from the optical pick-up block detector
9	IX	I	I-V converted RF signal (IX) input from the optical pick-up block detector
10	JX	I	I-V converted RF signal (JX) input from the optical pick-up block detector
11	JY	I	I-V converted RF signal (JY) input from the optical pick-up block detector
12	A	I	Signal (A) input from the optical pick-up detector
13	A-C	I	Signal (A) input from the optical pick-up detector (AC input)
14	B	I	Signal (B) input from the optical pick-up detector
15	TON-C	—	Connected to the external capacitor for the TON hold
16	CIG	—	Connected to the external capacitor for low-pass filter of the NPP divider denominator
17	CDN	—	Connected to the external capacitor for low-pass filter of the CSL divider denominator
18	PD-NI	I	Light amount monitor input terminal (non-invert input)
19	PD-I	I	Light amount monitor input terminal (invert input)
20	PD-O	O	Light amount monitor output terminal
21	ADFG	O	ADIP duplex FM signal (22.05 kHz \pm 1 kHz) output to the CXD2661GA (IC601)
22	DVDD	—	Power supply terminal (+2.4V) (digital system)
23	SBUS	I/O	Two-way SSB serial data bus with the system controller (IC801)
24	SCK	I	SSB serial clock signal input from the system controller (IC801)
25	$\overline{\text{XRST}}$	I	Reset signal input from the system controller (IC801) “L”: reset
26	OFTRK	I	Off track signal input from the CXD2661GA (IC601)
27	DGND	—	Ground terminal (digital system)
28	BOTM	O	Light amount signal (RF/ABCD) bottom hold output to the CXD2661GA (IC601)
29	PEAK	O	Light amount signal (RF/ABCD) peak hold output to the CXD2661GA (IC601)
30	VREF075	—	Connected to the external capacitor for the internal reference voltage
31	VC	O	Middle point voltage (+1.2V) generation output terminal
32	CCSL2	—	Connected to the external capacitor for low-pass filter of the TPP/WPP
33	RF OUT	O	Playback EFM RF signal output to the CXD2661GA (IC601)
34	AGND	—	Ground terminal (analog system)
35	EQ	—	Connected to the external capacitor for the RF equalizer
36	LP	—	Connected to the external capacitor for the RF equalizer
37	PS	—	Connected to the external capacitor for the RF equalizer
38	OFC-2	—	Connected to the external capacitor for the RF AC coupling
39	OFC-1	—	Connected to the external capacitor for the RF AC coupling
40	AVCC	—	Power supply terminal (+2.4V) (analog system)
41	ABCD	O	Light amount signal (ABCD) output to the CXD2661GA (IC601)
42	FE	O	Focus error signal output to the CXD2661GA (IC601)
43	S-MON	O	Servo signal monitor output to the system controller (IC801)
44	ADIP-IN	I	ADIP duplex FM signal (22.05 kHz \pm 1 kHz) input terminal Not used

• MAIN BOARD IC601 CXD2661GA-2

(DIGITAL SIGNAL PROCESSOR, DIGITAL SERVO SIGNAL PROCESSOR, EFM/ACIRC ENCODER/DECODER, SHOCK PROOF MEMORY CONTROLLER, ATRAC ENCODER/DECODER, D/A CONVERTER, 16M BIT D-RAM)

Pin No.	Pin Name	I/O	Description
1	VDCO	—	Power supply terminal (+1.8V) (for internal logic)
2, 3	MNT0, MNT1	O	Operation monitor signal output terminal Not used (open)
4	MNT2	O	Off track signal output to the SN761056DBT (IC501) and system controller (IC801)
5	MNT3	O	Focus OK signal output to the system controller (IC801) “H” is output when focus is on (“L”: NG)
6	SWDT	I	Serial data input from the system controller (IC801) and EEPROM (IC802)
7	SCLK	I	Serial clock signal input from the system controller (IC801)
8	XLAT	I	Serial data latch pulse input from the system controller (IC801)
9	VSCO	—	Ground terminal (for internal logic)
10	SRDT	O	Serial data output to the system controller (IC801) and EEPROM (IC802)
11	SENS	O	Internal status (SENSE) output to the system controller (IC801)
12	$\overline{\text{XRST}}$	I	Reset signal input from the system controller (IC801) “L”: reset
13	SQSY	O	Subcode Q sync (SCOR) output to the system controller (IC801) “L” is output every 13.3 msec Almost all, “H” is output
14	MTFLGL	O	Muting applied to analog signal input in non-signal status causes the signal to be “H” automatically Not used (open)
15	TST1	I	Input terminal for the test (normally : fixed at “L”)
16	XINT	O	Interrupt status output to the system controller (IC801)
17	TST2	I	Input terminal for the test (normally : fixed at “L”)
18	VDIOSC	—	Power supply terminal (+2.4V) (for oscillator cell)
19	OSCI	I	System clock input terminal (22.5792 MHz)
20	OSCO	O	System clock output terminal (22.5792 MHz)
21	VSIOOSC	—	Ground terminal (for oscillator cell)
22	DAVSSL	—	Ground terminal (for internal D/A converter L-ch)
23	VREFL	O	Reference voltage output terminal (for internal D/A converter L-ch)
24	AOUTL	O	Playback analog signal (L-ch) output to the headphone amp (IC301)
25	DAVDDL	—	Power supply terminal (+2.4V) (for internal D/A converter L-ch)
26	DAVDDR	—	Power supply terminal (+2.4V) (for internal D/A converter R-ch)
27	AOUTR	O	Playback analog signal (R-ch) output to the headphone amp (IC301)
28	VREFR	O	Reference voltage output terminal (for internal D/A converter R-ch)
29	DAVSSR	—	Ground terminal (for internal D/A converter R-ch)
30	VSC1	—	Ground terminal (for internal logic)
31	XTSL	I	Input terminal for the system clock frequency setting “L”: 45.1584 MHz, “H”: 22.5792 MHz (fixed at “H” in this set)
32	CD DSP	I	Chip select signal input from the system controller (IC801)
33	TST4	I	Input terminal for the test (normally : fixed at “L”)
34	DOUT	O	Digital audio signal output terminal when playback mode Not used (open)
35	DT72	O	Not used (open)
36, 37	VDC1, VDC2	—	Power supply terminal (+1.8V) (for internal logic)
38	DATAI	I	Input terminal of external audio data to the internal D/A converter Not used (open)
39 to 41	TST5 to TST7	I	Input terminal for the test (normally : fixed at “L”)
42	DADT	O	Playback data signal output to the external D/A converter Not used (open)
43	LRCK	O	L/R sampling clock signal (44.1 kHz) output to the external D/A converter Not used (open)
44	VSC2	—	Ground terminal (for internal logic)
45	XBCK	O	Bit clock signal (2.8224 MHz) output to the external D/A converter Not used (open)

Pin No.	Pin Name	I/O	Description
46	FS256	O	Clock signal (11.2896 MHz) output to the external D/A converter Not used (open)
47 to 52	A03, A04, A02, A05, A01, A06	O	Address signal output to the external D-RAM Not used (open)
53	VDIO1	—	Power supply terminal (+2.4V) (for I/O cell)
54	VSIO1	—	Ground terminal (for I/O cell)
55 to 59	A00, A07, A10, A08, A09	O	Address signal output to the external D-RAM Not used (open)
60	$\overline{\text{X}}\text{RAS}$	O	Row address strobe signal output to the external D-RAM “L” active Not used (open)
61	$\overline{\text{I}}\text{XOE}$	O	Output enable signal output terminal “L” active Not used (open)
62	$\overline{\text{I}}\text{XWE}$	O	Data write enable signal output terminal “L” active Not used (open)
63	$\overline{\text{X}}\text{CAS}$	O	Column address strobe signal output to the external D-RAM “L” active Not used (open)
64 to 67	D1, D2, D0, D3	I/O	Two-way data bus with the external D-RAM Not used (open)
68	VDC3	—	Power supply terminal (+1.8V) (for internal logic)
69	VSC3	—	Ground terminal (for internal logic)
70	A11	O	Address signal output to the external D-RAM Not used (open)
71	$\overline{\text{X}}\text{OE}$	O	Output enable signal output to the external D-RAM “L” active Not used (open)
72	$\overline{\text{X}}\text{WE}$	O	Data write enable signal output to the external D-RAM “L” active Not used (open)
73	MVCI	I	Digital in PLL oscillation input from the external VCO Not used (fixed at “L”)
74	ASYO	O	Playback EFM full-swing output terminal
75	ASYI	I	Playback EFM asymmetry comparator voltage input terminal
76	AVD1	—	Power supply terminal (+2.4V) (analog system)
77	BIAS	I	Playback EFM asymmetry circuit constant current input terminal
78	RFI	I	Playback EFM RF signal input from the SN761056DBT (IC501)
79	AVS1	—	Ground terminal (analog system)
80	PCO	O	Phase comparison output for master clock of the recording/playback EFM master PLL
81	FILI	I	Filter input for master clock of the recording/playback EFM master PLL
82	FILO	O	Filter output for master clock of the recording/playback EFM master PLL
83	CLTV	I	Internal VCO control voltage input of the recording/playback EFM master PLL
84	PEAK	I	Light amount signal (RF/ABCD) peak hold input from the SN761056DBT (IC501)
85	BOTM	I	Light amount signal (RF/ABCD) bottom hold input from the SN761056DBT (IC501)
86	ABCD	I	Light amount signal input from the SN761056DBT (IC501)
87	FE	I	Focus error signal input from the SN761056DBT (IC501)
88	AUX1	I	Auxiliary signal input terminal Not used (fixed at “H”)
89	VC	I	Middle point voltage (+1.2V) input terminal
90	ADIO	O	Monitor output of the A/D converter input signal Not used (open)
91	ADRT	I	A/D converter operational range upper limit voltage input terminal (fixed at “H” in this set)
92	AVD2	—	Power supply terminal (+2.4V) (analog system)
93	AVS2	—	Ground terminal (analog system)
94	ADRB	I	A/D converter operational range lower limit voltage input terminal (fixed at “L” in this set)
95	SE	I	Sled error signal input terminal Not used (open)
96	TE	I	Tracking error signal input from the SN761056DBT (IC501)
97	DCHG	I	Connected to the +2.4V power supply
98	APC	I	Error signal input for the laser automatic power control Not used (fixed at “H”)
99	ADFG	I	ADIP duplex FM signal (22.05 kHz \pm 1 kHz) input from the SN761056DBT (IC501)
100	VDIO2	—	Power supply terminal (+2.2V) (for I/O cell)
101	VSIO2	—	Ground terminal (for I/O cell)
102	FOCNT	O	Center frequency control signal output terminal of internal circuit filter Not used (open)

Pin No.	Pin Name	I/O	Description
103	XLRF	O	Serial latch signal output terminal Not used (open)
104	CKRF	O	Serial clock signal output terminal Not used (open)
105	DTRF	O	Write data output terminal Not used (open)
106	APCREF	O	Control signal output to the reference voltage generator circuit for the laser automatic power control
107	LDDR	O	PWM signal output for the laser automatic power control Not used (open)
108	VDC4	—	Power supply terminal (+1.8V) (for internal logic)
109	TRDR	O	Tracking servo drive PWM signal (–) output to the XC111256FTA (IC551)
110	TFDR	O	Tracking servo drive PWM signal (+) output to the XC111256FTA (IC551)
111	FFDR	O	Focus servo drive PWM signal (+) output to the XC111256FTA (IC551)
112	FRDR	O	Focus servo drive PWM signal (–) output to the XC111256FTA (IC551)
113	FS4	O	Clock signal output terminal (X' tal system 176.4 kHz) Not used (open)
114	SRDR	O	Sled servo drive PWM signal (–) output terminal Not used (open)
115	SFDR	O	Sled servo drive PWM signal (+) output terminal Not used (open)
116	VSC4	—	Ground terminal (for internal logic)
117	SPRD	O	Spindle servo drive PWM signal (–) output terminal Not used (open)
118	SPFD	O	Spindle servo drive PWM signal (+) output terminal Not used (open)
119	FGIN	I	FG signal input terminal for spindle servo Not used (open)
120 to 122	TEST1 to TEST3	I	Input terminal for the test (normally : fixed at “L”)
123	MFLGR	O	Muting applied to analog signal input in non-signal status causes the signal to be “H” automatically Not used (open)
124	SPVS	O	Spindle servo drive voltage control signal output to the XC111256FTA (IC551)
125	VDI03	—	Power supply terminal (+2.2V) (for I/O cell)
126	VSI03	—	Ground terminal (for I/O cell)
127	SPDU	O	Spindle servo (U) drive signal output to the XC111256FTA (IC551)
128	SPDV	O	Spindle servo (V) drive signal output to the XC111256FTA (IC551)
129	SPDW	O	Spindle servo (W) drive signal output to the XC111256FTA (IC551)
130	SPCU	I	Spindle servo (U) timing signal input from the XC111256FTA (IC551)
131	SPCV	I	Spindle servo (V) timing signal input from the XC111256FTA (IC551)
132	SPCW	I	Spindle servo (W) timing signal input from the XC111256FTA (IC551)
133	SLDU	O	Sled servo (1+) drive signal output to the XC111256FTA (IC551)
134	SLDV	O	Sled servo (1–) drive signal output to the XC111256FTA (IC551)
135	SLDW	O	Sled servo (2+) drive signal output to the XC111256FTA (IC551)
136	VDC5	—	Power supply terminal (+1.8V) (for internal logic)
137	VSC5	—	Ground terminal (for internal logic)
138	SLCU	I	Sled servo (1) timing signal input from the XC111256FTA (IC551)
139	SLCV	I	Sled servo (2) timing signal input from the XC111256FTA (IC551)
140	SLCW	O	Sled servo (2–) timing signal output to the XC111256FTA (IC551)
141	SLVS	O	Sled servo voltage control signal output to the XC111256FTA (IC551)
142	BYPS	O	By-pass transistor control signal output terminal Not used (open)
143	DVSSDRAM	—	Ground terminal (for internal 16M bit D-RAM)
144	DVDDDRAM	—	Power supply terminal (+2.4V) (for internal 16M bit D-RAM)
145	DVSSDRAM	—	Ground terminal (for internal 16M bit D-RAM)
146	DVDDDRAM	—	Power supply terminal (+2.4V) (for internal 16M bit D-RAM)
147 to 168	NC	—	Not used (open)

• SYSTEM BOARD IC801 CXR701080-010GA (SYSTEM CONTROLLER)

Pin No.	Pin Name	I/O	Description
1	NC	I	Not used (open)
2	OFTRK	I	Off track signal input from the CXD2661GA (IC601)
3, 4	NC	I	Not used (open)
5	NC	O	Not used (open)
6	SENSE	I	Internal status (SENSE) input from the CXD2661GA (IC601)
7	NC	O	Not used (open)
8	XLAT	O	Serial data latch pulse output to the CXD2661GA (IC601)
9	XCS DSP	O	Chip select signal output to the CXD2661GA (IC601)
10	NC	O	Not used (open)
11	SI0	I	Serial data input from the CXD2661GA (IC601)
12	SO0	O	Serial data output to the CXD2661GA (IC601)
13	SCK0	O	Serial clock signal output to the CXD2661GA (IC601) and EEPROM (IC802)
14	NC	I	Not used (open)
15	VSS	—	Ground terminal
16	VDD	—	Power supply terminal (+2.4V)
17	NC	O	Not used (open)
18	BEEP	O	Beep sound control signal output to the headphone amp (IC301)
19	RMC DTCK	I/O	TSB serial communication data input/output terminal for remote commander with headphone
20 to 22	NC	O	Not used (open)
23	XHP STBY	O	Standby on/off control signal output to the headphone amp (IC301) “L”: standby mode, “H”: amp on
24	CLV U	O	Spindle servo (U) drive signal input from the XC111256FTA (IC551)
25	CLV V	O	Spindle servo (V) drive signal input from the XC111256FTA (IC551)
26	CLV W	O	Spindle servo (W) drive signal input from the XC111256FTA (IC551)
27 to 32	NC	O	Not used (open)
33	LD ON	O	Laser diode on/off control signal output terminal “L”: laser off, “H”: laser on Not used (open)
34	NC	I	Not used (fixed at “H”)
35	SLD MON 1	I	Sled servo timing signal input from the CXD2661GA (IC601)
36	PD S0	O	PD IC mode switching signal output to the optical pick-up block
37	REG CTL CLK	O	Synchronizing external clock signal output terminal Not used (open)
38	PD S1	O	PD IC mode switching signal output to the optical pick-up block
39	FFCLR	O	Input latch output for starting signal to the MPC18A31FTA (IC901)
40	SLEEP	O	System sleep control signal output to the MPC18A31FTA (IC901) “H”: sleep on
41	NC	I	Not used (fixed at “L”)
42	NC	O	Not used (open)
43	$\overline{\text{XRST}}$	I	System reset signal input from the MPC18A31FTA (IC901) “L”: reset For several hundreds msec. after the power supply rises, “L” is input, then it changes to “H”
44	VSS	—	Ground terminal
45	XTAL	O	Main system clock output terminal (16.9344 MHz)
46	EXTAL	I	Main system clock input terminal (16.9344 MHz)
47	VDD	—	Power supply terminal (+2.4V)
48	NC	I/O	Not used (open)
49	SPDL START SW	O	Spindle servo start switching signal output terminal
50	NC	I	Not used (open)

Pin No.	Pin Name	I/O	Description
51	NC	I	Not used (fixed at "H")
52	FOK	I	Focus OK signal input from the CXD2661GA (IC601) "H": is input when focus is on ("L": NG)
53	SQSY	I	Subcode Q sync (SCOR) input from the CXD2661GA (IC601) "L" is input every 13.3 msec Almost all, "H" is input
54	NC	I	Not used (fixed at "H")
55	XINT	I	Interrupt status input from the CXD2661GA (IC601)
56	NC	I	Not used (open)
57	NC	O	Not used (open)
58	SERON	O	Series power supply control signal output to the MPC18A31FTA (IC901)
59	NC	O	Not used (open)
60	XTEST	I	Setting terminal for the test mode "L": test mode (normally: open)
61, 62	SET CODE0, SET CODE1	I	Destination setting terminal for the test mode Fixed at "L" in this set
63	SET CODE2	I	Destination setting terminal for the test mode Open in this set
64	REG CTL PWM	O	Synchronizing external clock signal output to the MPC18A31FTA (IC901)
65	VRM PWM	O	VREM power supply voltage control PWM signal output to the MPC18A31FTA (IC901)
66	VC PWM	O	System power supply voltage control PWM signal output to the MPC18A31FTA (IC901)
67	SPDL PWM	O	Spindle servo drive voltage control PWM signal output to the XC111256FTA (IC551)
68	XIC RST	O	Reset signal output to the SN761056DBT (IC501) and CXD2661GA (IC601) "L": reset
69	OPR	O	OPR LED (D801) drive signal output terminal "H": LED on
70	NC	I	Not used (fixed at "L")
71, 72	NC	O	Not used (open)
73	XHOLD SW	I	HOLD switch (S808) input terminal "L": hold on
74	VDD	—	Power supply terminal (+2.4V)
75	NC	I	Not used (open)
76	NC	O	Not used (open)
77	VSS	—	Ground terminal
78	VBKAN	I	Sub power supply input terminal
79	S MON	I	Servo signal monitor input from the SN761056DBT (IC501) (A/D input)
80	VB MON	I	Un-regulator power supply voltage monitor input terminal (A/D input)
81	NC	I	Not used (fixed at "L")
82	VREF MON	I	Reference voltage monitor input from the SN761056DBT (IC501) (A/D input)
83	WK DET	I	Set key starting detect signal input terminal (A/D input)
84	OPEN CLOSE SW	I	Upper panel open/close detect switch (S809) input terminal (A/D input) "L": upper panel close
85	RMC KEY	I	Remote commander with headphone key input terminal (A/D input)
86	SET KEY 1	I	Set key (S801 to 805) input terminal (A/D input) (■, ►►/►, ◀◀, VOL +/- keys input)
87	SET KEY 2	I	Set switch (S806) input terminal (A/D input) (DIGITAL SOUND PRESET switch input)
88	NC	I	Not used (fixed at "H")
89	VRM MON	I	VREM voltage monitor input terminal (A/D input)
90	NC	I	Not used (fixed at "L")
91	AD GND	—	Ground terminal (for A/D converter)
92	AVREF	I	Input terminal for power supply voltage adjustment reference voltage (+2.4V) (for A/D converter)
93	AVDD	—	Power supply terminal (+2.4V) (for A/D converter)
94, 95	TEST0, TEST1	I	Input terminal for the test (normally: fixed at "L")
96	TDI	I	Data input terminal for JTAG scan test Not used (open)

Pin No.	Pin Name	I/O	Description
97	TMS	I	Test mode control signal input terminal for JTAG scan test Not used (open)
98	TCX	I	Clock signal input terminal for JTAG scan test Not used (open)
99	TRST	I	Reset signal input terminal for JTAG scan test Not used (open)
100	TDO	O	Data output terminal for JTAG scan test Not used (open)
101	NC	O	Not used (open)
102	SSB DATA	I/O	Two-way SSB serial data bus with the SN761056DBT (IC501)
103	SSB CLK	O	SSB serial clock signal output to the SN761056DBT (IC501)
104	FLASH WR EN	I	Write enable signal input terminal Not used (fixed at "H")
105	VDD	—	Power supply terminal (+2.4V)
106	VSS	—	Ground terminal
107 to 109	NC	I	Not used (fixed at "H")
110, 111	NC	O	Not used (open)
112	XRST MTR DRV	O	Reset signal output terminal "L": reset Not used (open)
113, 114	NC	I	Not used (open)
115	XAVLS	I	Set switch (S807) input terminal (A/D input) (AVLS switch input) "L": limit
116	NC	O	Not used (open)
117	MUTE	O	Analog muting on/off control signal output to the headphone amp (IC301) "H": muting on
118	NC	O	Not used (open)
119	XCS NV	O	Chip select signal output to the EEPROM (IC802)
120	NC	O	Not used (open)

SECTION 7 EXPLODED VIEWS

NOTE:

- -XX and -X mean standardized parts, so they may have some difference from the original one.
- Color Indication of Appearance Parts
Example:
KNOB, BALANCE (WHITE) . . . (RED)
 ↑ ↑
 Parts Color Cabinet's Color

- Items marked "***" are not stocked since they are seldom required for routine service. Some delay should be anticipated when ordering these items.
- The mechanical parts with no reference number in the exploded views are not supplied.
- Accessories and packing materials are given in the last of the electrical parts list.

The components identified by mark Δ or dotted line with mark Δ are critical for safety. Replace only with part number specified.

(1) CABINET SECTION

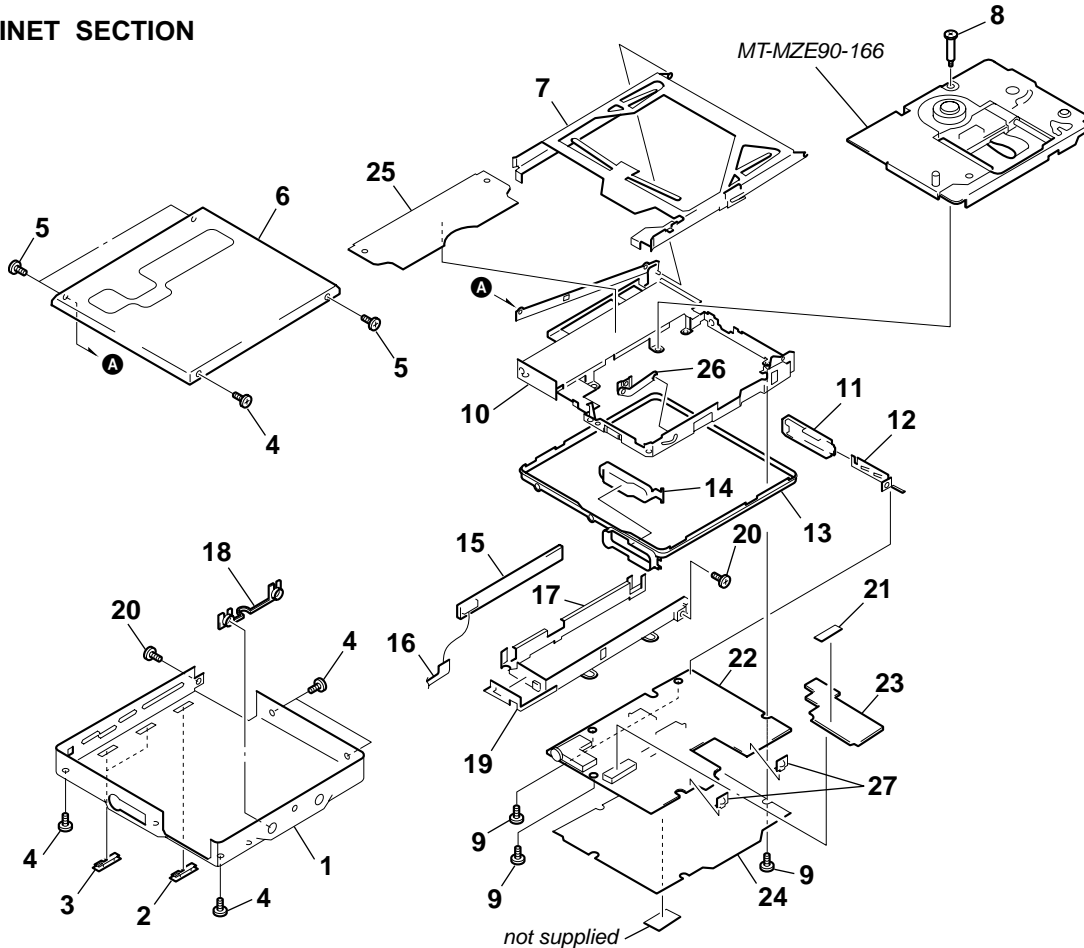

Ref. No.	Part No.	Description	Remark	Ref. No.	Part No.	Description	Remark
1	X-3378-970-1	PANEL ASSY (S), BOTTOM (SILVER)...(SILVER)		11	3-044-833-01	LID, BATTERY CASE (SILVER)...(SILVER)	
1	X-3378-971-1	PANEL ASSY (O), BOTTOM (ORANGE)...(ORANGE)		11	3-044-833-11	LID, BATTERY CASE (ORANGE)...(ORANGE)	
1	X-3378-972-1	PANEL ASSY (L), BOTTOM (BLUE)...(BLUE)		11	3-044-833-21	LID, BATTERY CASE (BLUE)...(BLUE)	
2	3-045-470-01	KNOB (AVLS) (SILVER)...(SILVER)		12	X-4952-176-1	TERMINAL (PLUS) ASSY, BATTERY	
2	3-045-470-11	KNOB (AVLS) (ORANGE)...(ORANGE)		13	3-044-832-01	STRIP, ORNAMENTAL	
2	3-045-470-21	KNOB (AVLS) (BLUE)...(BLUE)		14	3-044-838-01	BUTTON (OPEN)	
3	3-044-831-01	KNOB (HOLD) (SILVER)...(SILVER)		15	A-3322-552-A	SW BOARD, COMPLETE	
3	3-044-831-11	KNOB (HOLD) (ORANGE)...(ORANGE)		16	1-675-336-11	SWITCH FLEXIBLE BOARD	
3	3-044-831-21	KNOB (HOLD) (BLUE)...(BLUE)		17	3-044-837-01	CASE, BATTERY	
4	4-218-233-25	SCREW (1.4), MI		18	4-223-105-01	ESCUTCHEON	
5	4-218-233-05	SCREW (1.4), MI		19	4-223-920-01	TERMINAL BOARD (MINUS)	
6	X-3378-967-1	PANEL ASSY (S), UPPER (SILVER)...(SILVER)		20	4-963-883-22	SCREW (M1.4), PRECISION PAN	
6	X-3378-968-1	PANEL ASSY (O), UPPER (ORANGE)...(ORANGE)		21	3-042-755-01	SPACER (SYSTEM BOARD)	
6	X-3378-969-1	PANEL ASSY (L), UPPER (BLUE)...(BLUE)		22	A-3322-554-A	MAIN BOARD, COMPLETE	
7	X-4951-947-1	HOLDER ASSY		23	A-3322-555-A	SYSTEM BOARD, COMPLETE	
8	4-223-906-01	SCREW (MD), STEP		24	3-045-136-01	SHEET, INSULATING	
9	4-963-883-71	SCREW (M1.4), MI		25	3-047-261-01	SEAL (MOIRE) (GREEN/CIRCLE)...(SILVER)	
10	X-3378-668-1	CHASSIS ASSY, SET		25	3-047-261-11	SEAL (MOIRE) (BROWN/DOT)...(ORANGE)	
				25	3-047-261-21	SEAL (MOIRE) (LIGHT GREEN/WAVE)...(BLUE)	
				26	X-3378-684-1	BRACKET (STOP) ASSY	
				27	4-212-901-11	TERMINAL	

**(2) MECHANISM DECK SECTION
(MT-MZE90-166)**

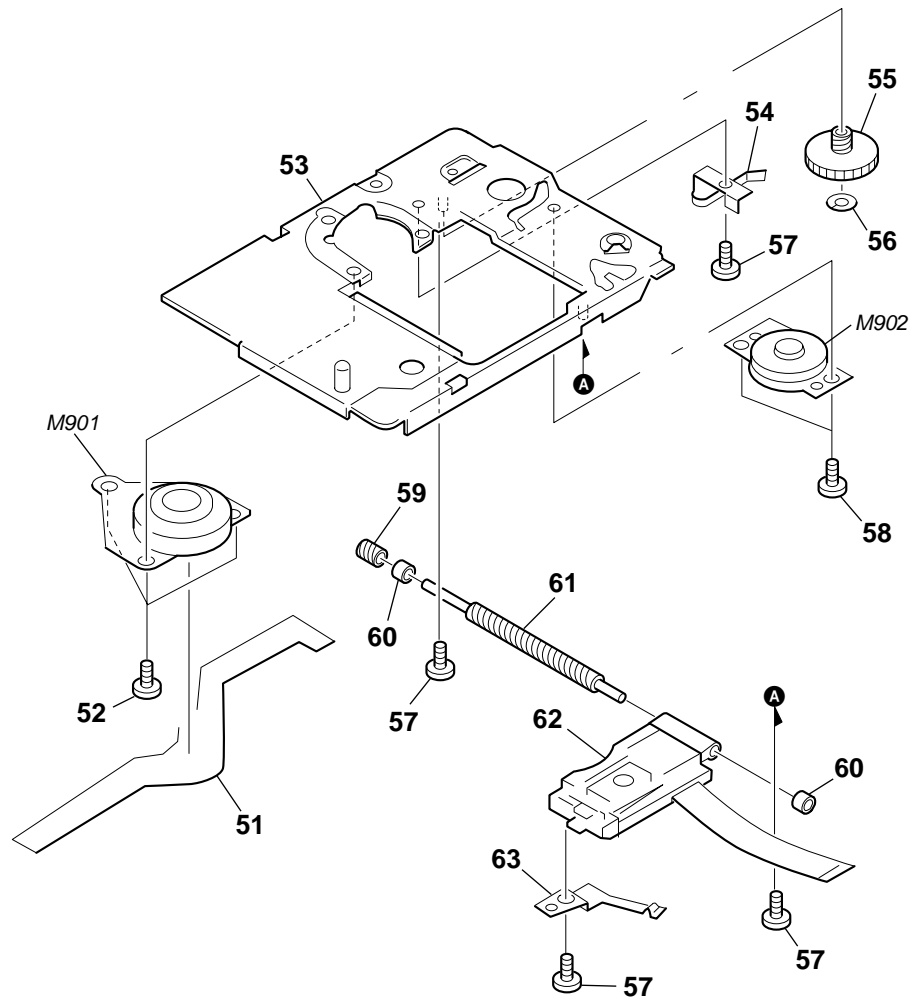

The components identified by mark \triangle or dotted line with mark \triangle are critical for safety. Replace only with part number specified.

Ref. No.	Part No.	Description	Remark	Ref. No.	Part No.	Description	Remark
51	1-675-668-11	MOTOR FLEXIBLE BOARD		59	4-222-208-01	GEAR (SB)	
52	4-963-883-42	SCREW (M1.4), PRECISION PAN		60	4-222-204-01	BEARING	
53	X-4951-926-1	CHASSIS ASSY		61	4-222-203-01	SCREW, LEAD	
54	4-222-206-01	SPRING, THRUST		\triangle 62	X-4952-387-1	SERVICE ASSY, OP (LCX-2E)	
55	4-222-216-01	GEAR (SA)		63	4-222-205-01	SPRING, RACK	
56	3-338-645-31	WASHER (0.8-2.5)		M901	8-835-666-01	MOTOR, DC SSM-01C14A/C-NP (SPINDLE)	
57	4-963-883-31	SCREW (M1.4), PRECISION PAN		M902	1-763-399-11	MOTOR, DC (SLED) (WITH PULLY)	
58	3-349-825-21	SCREW					

SECTION 8 ELECTRICAL PARTS LIST

NOTE:

- Due to standardization, replacements in the parts list may be different from the parts specified in the diagrams or the components used on the set.
- -XX and -X mean standardized parts, so they may have some difference from the original one.
- **RESISTORS**
All resistors are in ohms.
METAL: Metal-film resistor.
METAL OXIDE: Metal oxide-film resistor.
F: nonflammable

- Items marked “*” are not stocked since they are seldom required for routine service. Some delay should be anticipated when ordering these items.
- **SEMICONDUCTORS**
In each case, u: μ , for example:
uA. . : μ A. . uPA. . : μ PA. .
uPB. . : μ PB. . uPC. . : μ PC. .
uPD. . : μ PD. .
- **CAPACITORS**
uF: μ F
- **COILS**
uH: μ H

The components identified by mark Δ or dotted line with mark Δ are critical for safety. Replace only with part number specified.

When indicating parts by reference number, please include the board.

Ref. No.	Part No.	Description	Remark	Ref. No.	Part No.	Description	Remark
	A-3322-554-A	MAIN BOARD, COMPLETE *****					
		< CAPACITOR >					
C101	1-125-926-11	TANTALUM CHIP 4.7uF	20% 6.3V	C604	1-107-820-11	CERAMIC CHIP 0.1uF	16V
C104	1-164-942-11	CERAMIC CHIP 0.0068uF	10% 16V	C605	1-115-156-11	CERAMIC CHIP 1uF	10V
C201	1-125-926-11	TANTALUM CHIP 4.7uF	20% 6.3V	C606	1-117-919-11	TANTALUM CHIP 10uF	20% 6.3V
C204	1-164-942-11	CERAMIC CHIP 0.0068uF	10% 16V	C607	1-115-156-11	CERAMIC CHIP 1uF	10V
C351	1-107-820-11	CERAMIC CHIP 0.1uF	16V	C608	1-107-820-11	CERAMIC CHIP 0.1uF	16V
C501	1-125-777-11	CERAMIC CHIP 0.1uF	10% 6.3V	C609	1-119-749-11	TANTALUM CHIP 33uF	20% 4V
C502	1-127-772-11	CERAMIC CHIP 33000PF	10% 10V	C610	1-131-862-11	TANTALUM CHIP 47uF	20% 4V
C503	1-164-940-11	CERAMIC CHIP 0.0033uF	10% 16V	C611	1-164-943-11	CERAMIC CHIP 0.01uF	10% 16V
C504	1-164-940-11	CERAMIC CHIP 0.0033uF	10% 16V	C612	1-125-891-11	CERAMIC CHIP 0.47uF	10% 10V
C505	1-164-943-11	CERAMIC CHIP 0.01uF	10% 16V	C613	1-164-935-11	CERAMIC CHIP 470PF	10% 16V
C506	1-127-772-11	CERAMIC CHIP 33000PF	10% 10V	C614	1-127-772-11	CERAMIC CHIP 33000PF	10% 10V
C507	1-127-772-11	CERAMIC CHIP 33000PF	10% 10V	C615	1-125-777-11	CERAMIC CHIP 0.1uF	10% 6.3V
C508	1-164-938-11	CERAMIC CHIP 0.0015uF	10% 16V	C616	1-107-820-11	CERAMIC CHIP 0.1uF	16V
C509	1-164-940-11	CERAMIC CHIP 0.0033uF	10% 16V	C618	1-125-891-11	CERAMIC CHIP 0.47uF	10% 10V
C510	1-164-845-11	CERAMIC CHIP 5PF	0.25PF 16V	C619	1-164-943-11	CERAMIC CHIP 0.01uF	10% 16V
C511	1-164-845-11	CERAMIC CHIP 5PF	0.25PF 16V	C620	1-164-850-11	CERAMIC CHIP 10PF	0.5PF 16V
C513	1-164-858-11	CERAMIC CHIP 22PF	5% 16V	C851	1-164-156-11	CERAMIC CHIP 0.1uF	25V
C515	1-107-820-11	CERAMIC CHIP 0.1uF	16V	C853	1-164-156-11	CERAMIC CHIP 0.1uF	25V
C516	1-125-777-11	CERAMIC CHIP 0.1uF	10% 6.3V	C854	1-164-156-11	CERAMIC CHIP 0.1uF	25V
C517	1-164-943-11	CERAMIC CHIP 0.01uF	10% 16V	C855	1-164-156-11	CERAMIC CHIP 0.1uF	25V
C518	1-117-720-11	CERAMIC CHIP 4.7uF	10V	C901	1-104-752-11	TANTALUM CHIP 33uF	20% 6.3V
C519	1-164-940-11	CERAMIC CHIP 0.0033uF	10% 16V	C902	1-107-810-11	TANTALUM CHIP 33uF	20% 4V
C521	1-164-943-11	CERAMIC CHIP 0.01uF	10% 16V	C903	1-104-752-11	TANTALUM CHIP 33uF	20% 6.3V
C522	1-164-943-11	CERAMIC CHIP 0.01uF	10% 16V	C904	1-119-749-11	TANTALUM CHIP 33uF	20% 4V
C524	1-117-919-11	TANTALUM CHIP 10uF	20% 6.3V	C905	1-107-819-11	CERAMIC CHIP 0.022uF	10% 16V
C526	1-127-772-11	CERAMIC CHIP 33000PF	10% 10V	C906	1-107-819-11	CERAMIC CHIP 0.022uF	10% 16V
C527	1-127-772-11	CERAMIC CHIP 33000PF	10% 10V	C907	1-109-982-11	CERAMIC CHIP 1uF	10% 10V
C529	1-117-919-11	TANTALUM CHIP 10uF	20% 6.3V	C908	1-125-777-11	CERAMIC CHIP 0.1uF	10% 6.3V
C530	1-164-939-11	CERAMIC CHIP 0.0022uF	10% 16V	C911	1-117-919-11	TANTALUM CHIP 10uF	20% 6.3V
C551	1-125-777-11	CERAMIC CHIP 0.1uF	10% 6.3V	C915	1-164-943-11	CERAMIC CHIP 0.01uF	10% 16V
C552	1-125-777-11	CERAMIC CHIP 0.1uF	10% 6.3V	C916	1-164-943-11	CERAMIC CHIP 0.01uF	10% 16V
C553	1-107-765-11	TANTALUM CHIP 3.3uF	20% 16V	C917	1-107-826-11	CERAMIC CHIP 0.1uF	10% 16V
C554	1-107-765-11	TANTALUM CHIP 3.3uF	20% 16V	C918	1-164-943-11	CERAMIC CHIP 0.01uF	10% 16V
C555	1-135-238-21	TANTALUM CHIP 6.8uF	20% 10V	C952	1-127-569-11	TANTALUM CHIP 100uF	20% 4V
C556	1-135-238-21	TANTALUM CHIP 6.8uF	20% 10V	C953	1-127-569-11	TANTALUM CHIP 100uF	20% 4V
C557	1-127-772-11	CERAMIC CHIP 33000PF	10% 10V	C954	1-164-156-11	CERAMIC CHIP 0.1uF	25V
C558	1-127-772-11	CERAMIC CHIP 33000PF	10% 10V			< CONNECTOR >	
C559	1-127-772-11	CERAMIC CHIP 33000PF	10% 10V	* CN501	1-778-168-11	CONNECTOR, FFC/FPC (ZIF) 20P	
C561	1-164-156-11	CERAMIC CHIP 0.1uF	25V	* CN551	1-793-124-21	CONNECTOR, FPC (ZIP) 8P	
C603	1-107-820-11	CERAMIC CHIP 0.1uF	16V	* CN801	1-793-607-21	CONNECTOR, BOARD TO BOARD 50P	
				* CN802	1-785-219-22	CONNECTOR, FPC (ZIF) 9P	

Ref. No.	Part No.	Description	Remark	Ref. No.	Part No.	Description	Remark
		< DIODE >		R519	1-218-977-11	RES, CHIP 100K	5% 1/16W
D101	8-719-056-72	DIODE UDZ-TE-17-2.4B		R521	1-218-446-11	METAL CHIP 1	5% 1/16W
D201	8-719-056-72	DIODE UDZ-TE-17-2.4B		R551	1-218-965-11	RES, CHIP 10K	5% 1/16W
D601	8-719-421-27	DIODE MA728		R552	1-218-965-11	RES, CHIP 10K	5% 1/16W
D855	8-719-066-17	DIODE FTZ6.8E-T148		R553	1-218-965-11	RES, CHIP 10K	5% 1/16W
D901	8-719-066-16	DIODE RB491D-T146		R554	1-218-965-11	RES, CHIP 10K	5% 1/16W
D902	8-719-066-16	DIODE RB491D-T146		R555	1-218-965-11	RES, CHIP 10K	5% 1/16W
D903	8-719-420-51	DIODE MA729		R556	1-216-864-11	METAL CHIP 0	5% 1/16W
		< FERRITE BEAD >		R601	1-218-929-11	RES, CHIP 10	5% 1/16W
FB801	1-414-228-11	FERRITE BEAD		R602	1-218-929-11	RES, CHIP 10	5% 1/16W
FB802	1-414-228-11	FERRITE BEAD		R603	1-216-811-11	METAL CHIP 150	5% 1/16W
		< IC >		R604	1-218-973-11	RES, CHIP 47K	5% 1/16W
IC501	8-759-641-94	IC SN761056DBT		R605	1-218-965-11	RES, CHIP 10K	5% 1/16W
IC504	8-759-647-75	IC TC7W66FK (TE85R)		R606	1-218-977-11	RES, CHIP 100K	5% 1/16W
IC505	8-759-647-75	IC TC7W66FK (TE85R)		R607	1-218-987-11	RES, CHIP 680K	5% 1/16W
IC551	8-759-660-29	IC XC111256FTA		R608	1-218-977-11	RES, CHIP 100K	5% 1/16W
IC552	8-759-358-40	IC TLC372CPW-E20		R609	1-216-861-11	METAL CHIP 2.2M	5% 1/16W
@ IC601	8-752-400-59	IC CXD2661GA-2		R610	1-218-990-11	SHORT 0	
IC901	8-759-642-13	IC MPC18A31FTA		R611	1-218-975-11	RES, CHIP 68K	5% 1/16W
		< JACK >		R612	1-218-971-11	RES, CHIP 33K	5% 1/16W
J301	1-793-288-61	JACK (♻️) (HEADPHONE)		R614	1-218-965-11	RES, CHIP 10K	5% 1/16W
		< COIL >		R615	1-218-990-11	SHORT 0	
L501	1-469-570-21	INDUCTOR 10uH		R619	1-218-990-11	SHORT 0	
L502	1-469-570-21	INDUCTOR 10uH		R620	1-218-990-11	SHORT 0	
L551	1-410-389-31	INDUCTOR CHIP 47uH		R630	1-218-965-11	RES, CHIP 10K	5% 1/16W
L552	1-410-389-31	INDUCTOR CHIP 47uH		R809	1-218-973-11	RES, CHIP 47K	5% 1/16W
L553	1-414-400-41	INDUCTOR 22uH		R816	1-218-957-11	RES, CHIP 2.2K	5% 1/16W
L554	1-414-400-41	INDUCTOR 22uH		R817	1-218-941-11	RES, CHIP 100	5% 1/16W
L601	1-469-570-21	INDUCTOR 10uH		R818	1-218-941-11	RES, CHIP 100	5% 1/16W
L901	1-419-258-21	CHOKE COIL 68uH		R819	1-218-989-11	RES, CHIP 1M	5% 1/16W
L902	1-419-368-21	CHOKE COIL 47uH		R821	1-218-990-11	SHORT 0	
L903	1-469-525-91	INDUCTOR 10uH		R822	1-218-985-11	RES, CHIP 470K	5% 1/16W
L904	1-414-398-11	INDUCTOR 10uH		R828	1-218-973-11	RES, CHIP 47K	5% 1/16W
L905	1-414-404-41	INDUCTOR 100uH		R902	1-218-983-11	RES, CHIP 330K	5% 1/16W
		< TRANSISTOR >		R903	1-218-961-11	RES, CHIP 4.7K	5% 1/16W
Q501	8-729-922-10	TRANSISTOR 2SA1577-QR		R904	1-218-983-11	RES, CHIP 330K	5% 1/16W
Q901	8-729-046-48	FET FDV303N		R905	1-218-961-11	RES, CHIP 4.7K	5% 1/16W
Q902	8-729-037-53	TRANSISTOR 2SB1462J-QR (TX). SO		R909	1-218-959-11	RES, CHIP 3.3K	5% 1/16W
		< RESISTOR >		R910	1-218-959-11	RES, CHIP 3.3K	5% 1/16W
R105	1-218-951-11	RES, CHIP 680	5% 1/16W	R918	1-216-855-11	METAL CHIP 680K	5% 1/16W
R205	1-218-951-11	RES, CHIP 680	5% 1/16W	R920	1-218-871-11	METAL CHIP 10K	0.5% 1/16W
R501	1-218-971-11	RES, CHIP 33K	5% 1/16W	R921	1-218-979-11	RES, CHIP 150K	5% 1/16W
R502	1-218-979-11	RES, CHIP 150K	5% 1/16W	R922	1-218-989-11	RES, CHIP 1M	5% 1/16W
R503	1-216-864-11	METAL CHIP 0	5% 1/16W	R936	1-218-979-11	RES, CHIP 150K	5% 1/16W
R504	1-216-864-11	METAL CHIP 0	5% 1/16W	R937	1-218-989-11	RES, CHIP 1M	5% 1/16W
R505	1-208-691-11	METAL CHIP 2.2K	0.5% 1/16W	R938	1-218-989-11	RES, CHIP 1M	5% 1/16W
R515	1-208-691-11	METAL CHIP 2.2K	0.5% 1/16W	R940	1-218-977-11	RES, CHIP 100K	5% 1/16W
R516	1-208-691-11	METAL CHIP 2.2K	0.5% 1/16W	R941	1-218-967-11	RES, CHIP 15K	5% 1/16W
R517	1-208-691-11	METAL CHIP 2.2K	0.5% 1/16W	R942	1-218-963-11	RES, CHIP 6.8K	5% 1/16W
R518	1-218-985-11	RES, CHIP 470K	5% 1/16W	R943	1-218-957-11	RES, CHIP 2.2K	5% 1/16W
				R944	1-218-981-11	RES, CHIP 220K	5% 1/16W
						< COMPOSITION CIRCUIT BLOCK >	
				RB551	1-233-965-11	RES, NETWORK (CHIP TYPE) 4.7K	
				RB552	1-233-979-11	RES, NETWORK (CHIP TYPE) 1M	

@ Replacement of CXD2661GA-2 (IC601) used in this set requires a special tool. Therefore, it cannot be replaced.

MAIN SW SYSTEM

Ref. No.	Part No.	Description	Remark
< VIBRATOR >			
X601	1-781-654-21	VIBRATOR, CERAMIC (22.5792MHz)	

A-3322-552-A SW BOARD, COMPLETE			

< CONNECTOR >			
CN804	1-793-606-21	CONNECTOR, FFC/FPC (ZIF) 9P	
< DIODE >			
D801	8-719-061-82	LED TLSU1002 (TPX1, SONY) (OPR)	
< RESISTOR >			
R811	1-216-831-11	METAL CHIP 6.8K 5% 1/16W	
R812	1-216-833-11	RES, CHIP 10K 5% 1/16W	
R813	1-216-835-11	METAL CHIP 15K 5% 1/16W	
R814	1-216-839-11	METAL CHIP 33K 5% 1/16W	
< SWITCH >			
S801	1-771-138-21	SWITCH, KEY BOARD (■)	
S802	1-771-138-21	SWITCH, KEY BOARD (▶▶/▶▶)	
S803	1-771-138-21	SWITCH, KEY BOARD (◀◀)	
S804	1-771-138-21	SWITCH, KEY BOARD (VOLUME -)	
S805	1-771-138-21	SWITCH, KEY BOARD (VOLUME +)	
S806	1-571-506-41	SWITCH, SLIDE (DIGITAL SOUND PRESET)	
S807	1-571-275-31	SWITCH, SLIDE (AVLS)	
S808	1-571-275-31	SWITCH, SLIDE (HOLD)	
S809	1-771-483-61	SWITCH, PUSH (1 KEY) (OPEN/CLOSE)	

A-3322-555-A SYSTEM BOARD, COMPLETE			

< CAPACITOR >			
C102	1-125-899-11	TANTALUM CHIP 220uF 20% 4V	
C103	1-115-467-11	CERAMIC CHIP 0.22uF 10% 10V	
C202	1-125-899-11	TANTALUM CHIP 220uF 20% 4V	
C203	1-115-467-11	CERAMIC CHIP 0.22uF 10% 10V	
C301	1-117-919-11	TANTALUM CHIP 10uF 20% 6.3V	
C302	1-107-820-11	CERAMIC CHIP 0.1uF 16V	
C303	1-125-837-11	CERAMIC CHIP 1uF 10% 6.3V	
C304	1-125-926-11	TANTALUM CHIP 4.7uF 20% 6.3V	
C305	1-125-838-11	CERAMIC CHIP 2.2uF 10% 6.3V	
C306	1-117-919-11	TANTALUM CHIP 10uF 20% 6.3V	
C802	1-107-820-11	CERAMIC CHIP 0.1uF 16V	
C803	1-164-935-11	CERAMIC CHIP 470PF 10% 16V	
C804	1-164-943-11	CERAMIC CHIP 0.01uF 10% 16V	
C806	1-125-891-11	CERAMIC CHIP 0.47uF 10% 10V	
C807	1-125-891-11	CERAMIC CHIP 0.47uF 10% 10V	
C808	1-107-820-11	CERAMIC CHIP 0.1uF 16V	
C809	1-107-820-11	CERAMIC CHIP 0.1uF 16V	
C811	1-107-820-11	CERAMIC CHIP 0.1uF 16V	
< CONNECTOR >			
* CN803	1-793-608-21	CONNECTOR, BOARD TO BOARD 50P	

Ref. No.	Part No.	Description	Remark
< IC >			
IC301	8-759-598-15	IC TA2131FL (EL)	
@ IC801	8-752-914-08	IC CXR701080-010GA	
IC802	8-759-566-18	IC AK6480BH-E2	
< TRANSISTOR >			
Q301	8-729-037-52	TRANSISTOR 2SD2216J-QR (TX). SO	
< RESISTOR >			
R101	1-218-967-11	RES, CHIP 15K 5% 1/16W	
R102	1-218-961-11	RES, CHIP 4.7K 5% 1/16W	
R103	1-218-961-11	RES, CHIP 4.7K 5% 1/16W	
R104	1-218-929-11	RES, CHIP 10 5% 1/16W	
R201	1-218-967-11	RES, CHIP 15K 5% 1/16W	
R202	1-218-961-11	RES, CHIP 4.7K 5% 1/16W	
R203	1-218-961-11	RES, CHIP 4.7K 5% 1/16W	
R204	1-218-929-11	RES, CHIP 10 5% 1/16W	
R301	1-218-935-11	RES, CHIP 33 5% 1/16W	
R302	1-218-963-11	RES, CHIP 6.8K 5% 1/16W	
R303	1-218-981-11	RES, CHIP 220K 5% 1/16W	
R801	1-218-981-11	RES, CHIP 220K 5% 1/16W	
R802	1-218-981-11	RES, CHIP 220K 5% 1/16W	
R803	1-218-985-11	RES, CHIP 470K 5% 1/16W	
R804	1-218-973-11	RES, CHIP 47K 5% 1/16W	
R806	1-218-977-11	RES, CHIP 100K 5% 1/16W	
R807	1-218-959-11	RES, CHIP 3.3K 5% 1/16W	
R808	1-218-959-11	RES, CHIP 3.3K 5% 1/16W	
R810	1-218-973-11	RES, CHIP 47K 5% 1/16W	
R815	1-218-941-11	RES, CHIP 100 5% 1/16W	
R826	1-216-864-11	METAL CHIP 0 5% 1/16W	
R827	1-218-989-11	RES, CHIP 1M 5% 1/16W	
< VIBRATOR >			
X801	1-781-575-21	VIBRATOR, CERAMIC (16.9344MHz)	

MISCELLANEOUS			

16	1-675-336-11	SWITCH FLEXIBLE BOARD	
51	1-675-668-11	MOTOR FLEXIBLE BOARD	
△ 62	X-4952-387-1	SERVICE ASSY, OP (LCX-2E)	
M901	8-835-666-01	MOTOR, DC SSM-01C14A/C-NP (SPINDLE)	
M902	1-763-399-11	MOTOR, DC (SLED) (WITH PULLY)	

@ Replacement of CXR701080-010GA (IC801) used in this set requires a special tool. Therefore, it cannot be replaced.

The components identified by mark △ or dotted line with mark △ are critical for safety. Replace only with part number specified.

<u>Ref. No.</u>	<u>Part No.</u>	<u>Description</u>	<u>Remark</u>
	ACCESSORIES & PACKING MATERIALS		

	1-418-493-61	REMOTE CONTROL UNIT (RM-MZ2S)	
△	1-528-580-21	BATTERY CHARGER (BC-7HT) (Tourist)	
△	1-528-866-11	BATTERY CHARGER (BC-9HP2) (Hong Kong)	
	1-528-918-11	BATTERY CASE	
	1-569-007-11	ADAPTOR, CONVERSION 2P (Tourist)	
	1-756-036-11	BATTERY, NICKEL HYDROGEN	
	3-043-060-01	CASE, CHARGE (C/D)	
	3-045-575-01	CASE, CARRYING	
	3-046-782-01	MANUAL, INSTRUCTION (JAPANESE, ENGLISH) (Tourist)	
	3-046-782-11	MANUAL, INSTRUCTION (ENGLISH, CHINESE) (Hong Kong)	
	8-953-304-90	RECEIVER MDR-E805SP	

The components identified by mark △ or dotted line with mark △ are critical for safety. Replace only with part number specified.

