

MZ-2P

SERVICE MANUAL

*US Model
Canadian Model
AEP Model
UK Model*



SPECIFICATIONS

System

Audio playing system
MiniDisc digital audio system

Laser diode properties
Material: GaAlAs
Wavelength: $\lambda = 780 \text{ nm}$
Emission duration: continuous
Laser output: less than $44.6 \mu\text{W}$
(This output is the value measured at a distance of 200 mm from the lens surface on the optical pick-up block.)

Revolutions
400 rpm to 900 rpm (CLV)

Error correction
Advanced Cross Interleave Reed Solomon Code (ACIRC)

Sampling frequency
44.1 kHz

Modulation system
EFM (Eight to Fourteen Modulation)

Number of channels
2 stereo channels

Frequency response
20 to 20,000 Hz $\pm 1 \text{ dB}$

Wow and Flutter
Below measurable limit

Outputs

	Jack Type	Rated Output	Maximum Output Level	Load Impedance
Headphones	Stereo mini-jack	—	5 mW + 5 mW	16 Ω
Line Out	Stereo mini-jack	245 mV	—	10 k Ω

Model Name Using similar Mechanism	NEW
Mechanism Type	MT-MZ2P-1 06
Optical Pickup Block Type	KMS-130A

General

Power requirements

- BP-MZ1 Rechargeable Battery (supplied)
- Sony AC Power Adaptor (supplied) connected at the DC IN 10.5 V jack:
 - 120 V AC, 60 Hz (US, Canadian model)
 - 220-230 V AC, 50 Hz (AEP model)
 - 100-240 V AC, 50/60 Hz (Other models)
 - 240 V AC, 50 Hz (UK model)
- DCC-E1105L Sony Car Battery Cord (not supplied) connected at the DC IN 10.5 V jack: 12 V car battery

Battery operation time

75 minutes of consecutive play with fully charged BP-MZ1

Dimensions

Approximately 114 × 42 × 139 mm (w/h/d) (4 $\frac{1}{2}$ × 1 $\frac{11}{16}$ × 5 $\frac{1}{2}$ in.)

Weight

Approximately 680 g (1 lb 8 oz) incl. rechargeable battery

— Continued next page —

PORTABLE MINIDISK PLAYER SONY®



Accessories

Supplied

- AC-MZ1 AC Power Adaptor (1)
- BP-MZ1 Rechargeable Battery (1)
- Stereo Headphones (1)
- Line Cable (stereo mini-plug-2 phono plugs) (1)
- Carrying Case (1)

Design and specifications subject to change without notice.

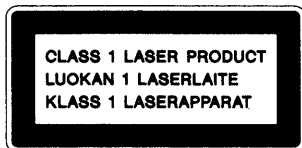

Note

This appliance conforms with EEC Directive 87/308/EEC regarding interference suppression.



This MiniDisc Player is classified as a CLASS 1 LASER product. The CLASS 1 LASER PRODUCT label is located on the bottom exterior.

SAFETY-RELATED COMPONENT WARNING!!

COMPONENTS IDENTIFIED BY MARK  OR DOTTED LINE WITH MARK  ON THE SCHEMATIC DIAGRAMS AND IN THE PARTS LIST ARE CRITICAL TO SAFE OPERATION. REPLACE THESE COMPONENTS WITH SONY PARTS WHOSE PART NUMBERS APPEAR AS SHOWN IN THIS MANUAL OR IN SUPPLEMENTS PUBLISHED BY SONY.

ATTENTION AU COMPOSANT AYANT RAPPORT À LA SÉCURITÉ!

LES COMPOSANTS IDENTIFIÉS PAR UNE MARQUE  SUR LES DIAGRAMMES SCHÉMATIQUES ET LA LISTE DES PIÈCES SONT CRITIQUES POUR LA SÉCURITÉ DE FONCTIONNEMENT. NE REMPLACER CES COMPOSANTS QUE PAR DES PIÈCES SONY DONT LES NUMÉROS SONT DONNÉS DANS CE MANUEL OU DANS LES SUPPLÉMENTS PUBLIÉS PAR SONY.

TABLE OF CONTENTS

<u>Section</u>	<u>Title</u>	<u>Page</u>
SECTION 1. GENERAL		3
SECTION 2. DISASSEMBLY		
2-1.	Upper Panel and Bottom Panel	13
2-2.	Control Board	14
2-3.	Main Board	15
2-4.	Battery Case	15
2-5.	Eject Shutter	16
2-6.	Mechanical Deck	17
2-7.	Optical Pickup Block	19
2-8.	Holder Assy And Main Slider Assy	
	1. Removal	20
	2. Assembling	21
2-9.	Sled Motor	22
2-10.	Loading Motor	22
2-11.	Spindle Motor	23
SECTION 3. PIN FUNCTION		24
SECTION 4. TEST MODE		28
SECTION 5. ELECTRICAL ADJUSTMENTS		30
SECTION 6. DIAGRAMS		
6-1.	Block Diagram	35
6-2.	Circuit Boards Location	36
6-3.	Printed Wiring Boards—Control/Power Section—	37
6-4.	Schematic Diagrams—Control/Power Section—	41
6-5.	Printed Wiring Boards—Main Section—	46
6-6.	Schematic Diagrams—Main Section-1—	51
6-7.	Schematic Diagrams—Main Section-2—	56
	· IC Block Diagrams	61
SECTION 7. EXPLODED VIEWS		
7-1.	Upper Panel And Bottom Panel Section	62
7-2.	Chassis Section	63
7-3.	Mechanism Section-1(MT-MZ2P-106)	64
7-4.	Mechanism Section-2(MT-MZ2P-106)	65
SECTION 8. ELECTRICAL PARTS LIST		66

Welcome !

Welcome to the world of the MiniDisc ! The Sony MiniDisc Player is the result of Sony's on-going commitment to leadership in audio-video technology. Here are some of the capabilities and features you'll discover with the new MiniDisc Player.

Quick Random Access
You can access any music track or phrase without waiting for reeling time.

Digital Sound
MiniDiscs play with nearly the same noiseless, high-fidelity sound as CDs.

Title Function
Displays the disc and track names when you play premastered discs.

Shock-Resistant Memory
The MiniDisc Player protects discs against shocks and vibrations during playback. This means no jitters or skipping while you are jogging or driving.

Hold Function
This feature locks the controls so that none of the buttons are accidentally operated while you're walking or jogging.

What is the MiniDisc?

How MiniDiscs work

MiniDiscs (MD) come in two types: premastered (pre-recorded) and recordable (blank). Premastered MDs, recorded at music studios, can be played back almost endlessly. However, they can't be recorded on or over like cassette tapes. To record, you use a "recordable MD".

Premastered MDs
Premastered MDs are recorded and played like regular CDs. A laser beam focuses on the pits in the surface of the MD and reflects the information back to the lens in the player. The player then decodes the signals and plays them back as music.

Recordable MDs
Recordable MDs, which use magneto-optical (MO) technology, can be recorded again and again. The laser inside the player applies heat to the MD, demagnetizing the magnetic layer of the MD. A new magnetic field corresponding to the audio input signal is applied to the magnetic layer of the disc. The result is a recorded MD.

How the MiniDisc got so small

The 2.5-inch MiniDisc, encased in a cartridge that looks like a 3.5-inch diskette (see *Illustration below*), uses a new digital audio compression technology called ATRAC (Adaptive Transform Acoustic Coding). To store more sound in less space, ATRAC extracts and encodes only those frequency components actually audible to the human ear.

Parts Making Up a MiniDisc

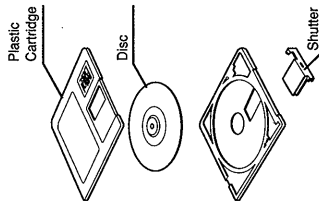

How Quick Random Access and the TOC systems work

Like CDs, MDs offer instantaneous random access to the beginning of any music track. Premastered MDs are recorded with location addresses corresponding to each music selection. Recordable MDs are manufactured with a "User TOC* Area" to contain the order of the music. The TOC system is similar to the "directory management system" of floppy disks. In other words, starting and ending addresses for all music tracks recorded on the disc are stored in this area. This lets you randomly access the beginning of any track (AMS), as well as label the location with a track name as you would a file on a diskette.

* TOC is the acronym for Table of Contents.

SECTION 1 GENERAL

This section is extracted from instruction manual.

How the Shock-Resistant Memory works

One major drawback of optical read systems is that they can skip or mute when subjected to vibration. The MD system resolves this problem by using a buffer memory that stores up to 3 seconds of audio data. This is possible because of a 1 second lag between the time audio data is picked up and when it is decoded (see *Illustration below*). Should the optical pickup be jarred out of position, the correct audio data plays from the buffer memory. Using a concept called "sector repositioning," the optical pickup has the ability to within 13 milliseconds identify the disruption and resume reading from the correct point. As long as the optical pickup returns to the correct position within 3 seconds, you never experience mistracking or muting.

Shock-Resistant Memory System

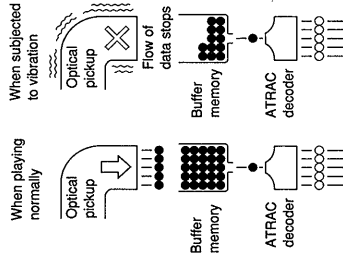

Unpacking

Take the player out of the box and check that you have all the supplied accessories. You should have:

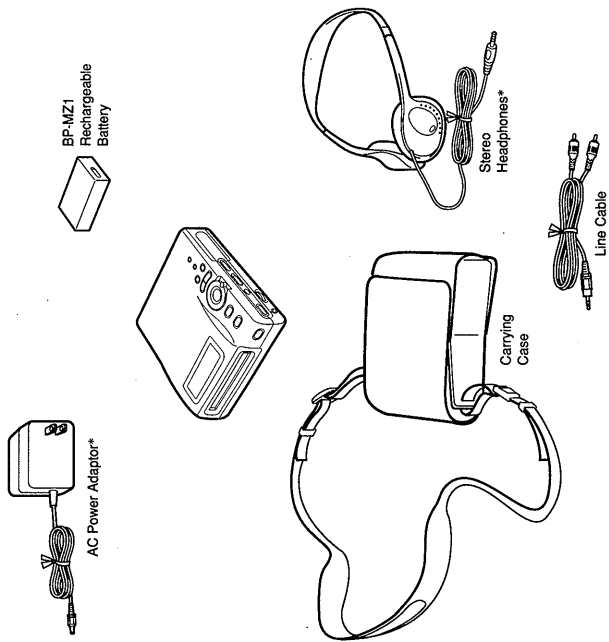

* Illustration conforms to US model.

Looking at the controls

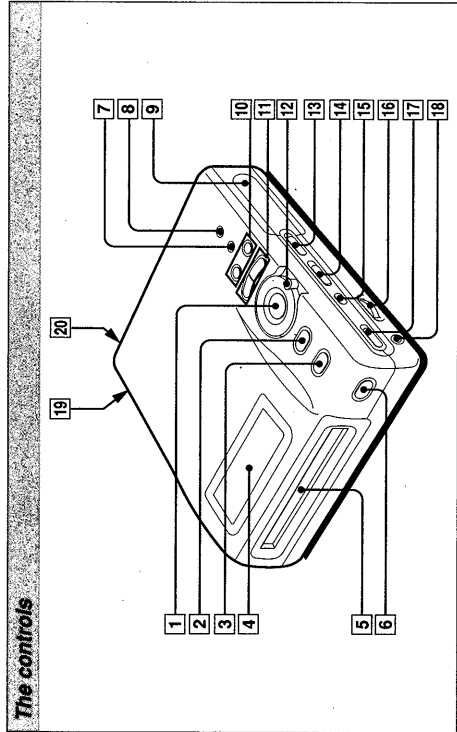

- 1** ▶ Play button
Press to start playing an MD.
- 2** || Pause button
Press to momentarily interrupt play.
- 3** ■ STOP/CHARGE
Press to stop the MD or to charge the battery.
- 4** Display window
Display window
- 5** Disc compartment
Insert the MD here. The power goes on automatically.
- 6** Eject button
Press to remove an MD. The power goes off automatically.
- 7** ENTER/REPEAT
Press to enter programmed selections or repeat tracks.
- 8** DISPLAY MODE
Press to display the recorded date, MD or track name.
- 9** Rechargeable battery compartment
—10/4-10 Skip buttons
- 10** Press to jump ten tracks back or ahead.
- 11** ◀◀▶▶ AMS (Automatic Music Sensor) buttons
Press to find the beginning of a track.
- 12** ◀▶ Search ring
Move up or down to find a particular point in a track.
- 13** RESUME
Slide to play from the point the MD stopped.
- 14** BASS BOOST
Select to emphasize low frequency (bass) sounds.
- 15** PLAY MODE
Press once to play a single track, twice tracks in random order, or three times to set up a play list of up to 21 selections.
- 16** VOLUME
Rotate to adjust the volume through the headphones.
- 17** HOLD
Slide to lock the controls.
- 18** ◻ Headphones jack
- 19** OPTICAL (DIGITAL)/LINE OUT
To play or record with analog or digital equipment (see pages 12 and 13 for connections).
- 20** DC IN 10.5 V
Connect the supplied AC power adaptor here.

Looking at the controls

The display window

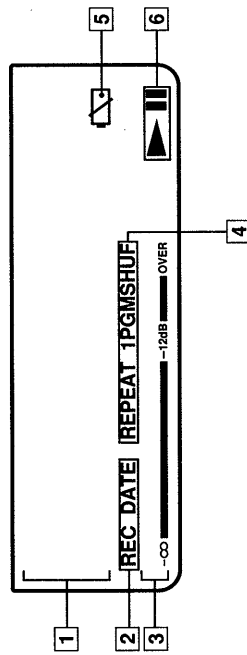

- 1 Character information display
Displays the recorded date, disc and track names.
- 2 REC DATE
Lights up along with the date to show when the MD was recorded.
- 3 Level meter
Shows the volume on the MD being played.
- 4 Play mode indicators
1: lights to indicate one track will play.
PGM: lights to indicate a programmed play list will play.
SHUF: lights to indicate tracks will play in random order.
REPEAT: lights to indicate tracks will be repeated according to the play mode chosen.
- 5 Battery indicator
Flashes when the battery is weak or dead.
- 6 Play and pause indicators
▶ indicates the MD is playing; ■ indicates the MD has paused.

Choosing power sources

Using the player on AC power

Note on the AC power adaptor
Use the supplied AC power adaptor only. Do not use any other AC power adaptor.

The MiniDisc Player is operable on AC and rechargeable battery power. To operate the player on AC power, just insert the narrow end of the supplied AC power adaptor to the terminal on the player marked DC IN 10.5 V and the other end to the wall outlet. To operate the player on battery power, read the following section.



Polarity of the plug

Installing the rechargeable battery

Before using the rechargeable battery for the first time, you must charge it.

- 1 Slide open the battery compartment lid (as shown) and insert the battery.

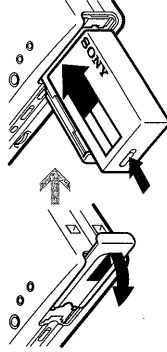

- 2 Close the compartment lid.
(See the next section for how to charge the battery.)

Choosing power sources

Charging the battery

Ideally, the player should be operated until no charge remains (the battery indicator flashes). You should avoid recharging a half-charged battery. If any charge is left when the battery starts charging,

the player will discharge the residual amount ("refreshing") to avoid weakening the capacity of the battery.

- 1 After you have installed the rechargeable battery, connect the supplied AC power adaptor.

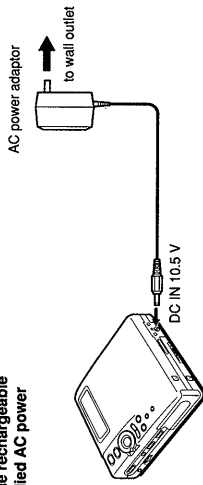

- 2 Press ■ STOP/CHARGE to start charging the battery.

"REFRESHING" lights in the display as residual battery charge is discharged. Refreshing may take up to one hour depending on how much charge is left.

The display changes to "CHARGING" when refreshing ends. When the battery is ready to use, "CHARGING" goes out. Charging takes from 60 to 90 minutes.

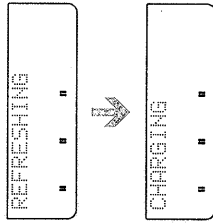

- 3 Disconnect the AC power adaptor.

The battery should operate the player for about 75 minutes before you need to charge it again.

When to charge the battery

When the battery is weak, the  low battery indication will flash continuously. Recharge the battery then.

When to replace the rechargeable battery

When the operating time of the fully charged battery decreases to about half, replace it with a new one (BP-MZ1).

Recharging and battery cautions

- Be sure to use the supplied AC power adaptor.
- Use the battery where the temperature is between 41° and 95° F (5° and 35°C) for the best results.
- Do not discard the battery in fire.
- Do not short-circuit the battery.
- Do not disassemble the battery. If the electrolyte inside the battery should come into contact with clothes or skin, immediately wash the contaminated objects with water.

Connecting to a stereo system

The MiniDisc Player is connectable to a digital or analog stereo system. Once hooked up, the player automatically recognizes the device as digital or analog. Note, however, that you can't hook up

a digital device unless it has the same sampling frequency as the MD player (44.1 kHz). If it isn't the same, use the analog connection described in the following section.

Hooking up a digital amplifier

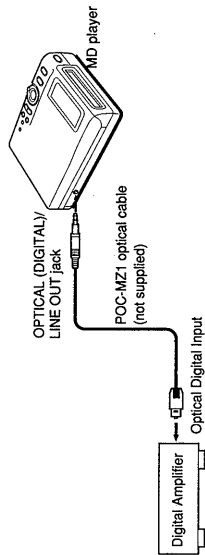

Note
To ensure good signal transmission, keep the plug ends of the optical cable free from tarnish.

Hooking up an analog amplifier (or tape player)

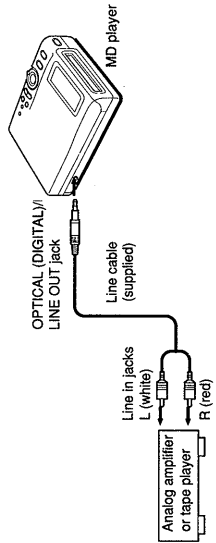

Playing an MD (normal play)

Listening to an MD is easy — just plug in the headphones, insert the MD and turn up the volume.

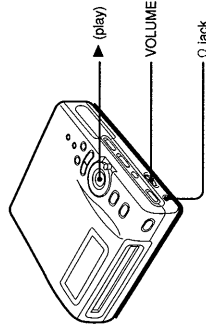

1 Connect the headphones at the jack marked .

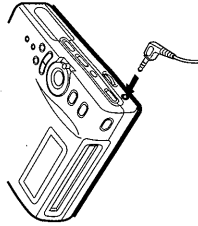

2 With the label side up, and the arrow pointing toward the opening (as shown), slide the MD into the disc compartment until the player grips it.

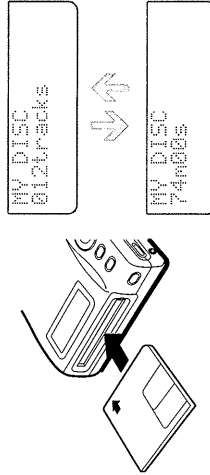

The power will go on automatically. The name of the MD will light on the first line. The second line will alternate between the total number of tracks and the total playing time.

3 Press (play).

The track number, playing time and name light up in the display window, and the MD starts playing. If "REPEAT" is lit in the display window, all the tracks will play again. (See *Playing tracks repeatedly*.)



4 Adjust the volume.

(See the section, *Emphasizing the bass*.)

To	Press
stop play	STOP/CHARGE*
interrupt play momentarily	(pause)
resume play after pause	(play) or (pause)
eject the MD	(eject)

* When you stop the player, the power goes off.

Playing specific tracks

You can quickly find any track while playing an MD using the -10/+10 Skip and AMS (Automatic Music Sensor) buttons. You can also find tracks while in pause mode.

To Skip	Press
to the beginning of the current or preceding tracks	
to the beginning of the next or succeeding tracks	
back ten tracks	-10
forward ten tracks	+10

Playing from a particular point in a track

While listening to an MD you may want to hear a particular section of a track. To find that section, rotate the Search ring until you hear the part you want. Release it to return to normal play.



To	Turn the ring to
search backward	
search forward	

Emphasizing the bass

The BASS BOOST feature intensifies low frequency sound for richer quality audio reproduction.



To emphasize	Set to
heavy bass slightly	MID
heavy bass greatly	MAX
no emphasis	NORM

Note
If the volume is too high, the sound may crack or distort. If this happens, turn down the volume.

Displaying disc and track names

If you are playing a premastered or recorded MD that's been electronically labeled, you can display information on the MD while it's playing or paused.*

To display	Press DISPLAY MODE
date recorded (if not a premastered MD)	once
name of MD playing	twice
name of track playing (normal display)	three times

* Some premastered MDs may not have been electronically labeled.

Playing a single track

Because of the durable nature of MDs, you can play a favorite track once or over and over without wear to the disc.

To play a track once just follow the procedure below. To play the same track repeatedly, see *Playing tracks repeatedly*.

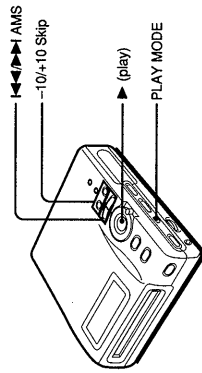

- 1 Press **(play)**.
- 2 Display the track number you want to play using the **AMS** or one of the **-10/+10 Skip** buttons.
- 3 Press **PLAY MODE** until "1" lights in the display window.

The player will stop after the current selection has played. If "REPEAT" is lit in the display window, the same track will play continuously.

To stop single track play
Press **STOP/CHARGE**.

To cancel single track play
Press **PLAY MODE** until "1" disappears from the display window.

Playing tracks in random order (shuffle play)

In shuffle play tracks will play in random order. For example, instead of tracks 5, 6, 7 playing in order, they will be play in any order such as 6, 5, 7.

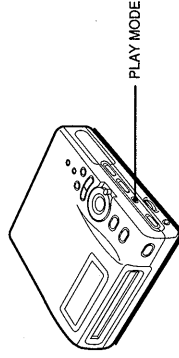

While the MD is playing, press **PLAY MODE** until "SHUF" lights in the display window.

"Access" lights up in the display while the player is looking for the first track to play.

The player will stop after all the tracks on the MD have played randomly. If "REPEAT" is lit in the display window, the MD will play in a continuously random order. (See *Playing tracks repeatedly*.)

To stop shuffle play
Press **STOP/CHARGE**.

To cancel shuffle play
Press **PLAY MODE** until "SHUF" disappears from the display window.

Note
When you press **AMS** or rotate the Search ring to the MD returns to the beginning of the current track only. To go back beyond the current track, you must cancel shuffle play.



Playing tracks in specific order (program play)

You can program up to 21 tracks to play in any order you like. Just enter the track numbers you want played in the order you want them played.

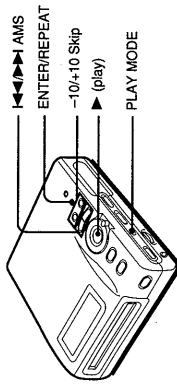

- 1 While the MD is playing, press **PLAY MODE** until "PGM" lights in the display window.

"PGM" will flash signaling you to enter a track number.



- 2 Press one of the **AMS** or **-10/+10** Skip buttons until the track you want to program lights in the display.

The player continues to play the current selection and the track you selected appears in the display.



- 3 When you've found the track you want to program, press **ENTER/REPEAT** to enter your choice.



- 4 Repeat steps 2 and 3 until you have entered all the tracks you want played.

You can program up to 21 tracks.

Note

If you try to program more than 21 tracks, the step number display will return to "1". If that happens, every track you program beyond the list will erase a programmed track number starting from the first.

- 5 Decide whether or not the order you want the tracks to play is correct (if not, see the options below), then press **ENTER/REPEAT**.

If tracks are left from a previous play list, enter "0" to erase the succeeding tracks. "PGM" lights and the first track of the new play list is displayed.

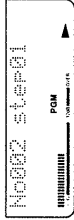

- 6 Press **(play)**.

The player will stop after playing all the tracks in the play list. If "REPEAT" is lit, the play list will play continuously. (See *Playing tracks repeatedly*.) The programmed play list will stay in memory until you program over it, erase it, take out the disc or turn off the player.

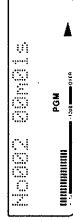

- To check the order of the tracks you've entered

Before pressing **(play)**, press **ENTER/REPEAT**. Each time you press **ENTER/REPEAT**, the next track number lights in the display.

Tracks 6, 2 and 9 have been entered.

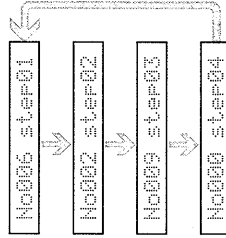

(Nothing has been programmed from the fourth step on.)

- To change the order of a play list

After you have pressed **(play)**, you can only change the order of the tracks by re-programming new tracks over the old ones. Do this by following steps 1 through 5. Those tracks you do not program over will remain in the play list. For example, the old play list contains tracks 2, 3 and 4 and you program tracks 1 and 2 over 2 and 3. The new program will play tracks 1, 2 and 4. You can also erase the whole program, then re-enter a completely new program.

To erase a program

Display "PGM" and enter "0" at the beginning of the programmed tracks you want to erase. The succeeding programmed tracks will be cleared. For example, if you want to erase all the tracks in a play list, enter "0" at the first track. If you want to erase the 5th through last programmed track, enter "0" at the 5th track.

To stop a program while playing

Press **STOP/CHARGE**.

To cancel program play

Press **PLAY MODE** until "PGM" disappears. The programmed play list will not be erased.

To change a track in the program

Before pressing **(play)**, press **ENTER/REPEAT** to display the track you want to change. Press an **AMS** or **-10/+10** Skip button until the track number changes to the one you want. Press **ENTER/REPEAT** to save the new number.

Playing tracks repeatedly

You can play tracks repeatedly in normal, single, shuffle or program play modes. In shuffle mode, the tracks will be repeated in a different order each time they are played. For how to normal play, see

Playing an MD: for single play, see *Playing a single track*; for shuffle play, see *Playing tracks in random order*; for program play, see *Playing tracks in specific order*.

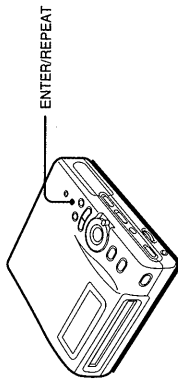

While the MD is playing, press ENTER/REPEAT until "REPEAT" appears in the display window.

Make sure you press ENTER/REPEAT sometime before play ends. For example, when playing a single track, press ENTER/REPEAT before the track finishes. When playing programmed tracks, press ENTER/REPEAT before the play list ends.

The MD player will play all the desired tracks beginning from the designated first track, then go back and play them again.



Useful tips

Playing from where the MD stopped

Instead of pressing II (pause), use the Resume function, to resume playback (in the same mode) from where the disk stopped playing. This is useful when you don't want the player to expend energy (as it would in pause mode), or start playing from the first track (as it would if you pressed ■ STOP/CHARGE only). The Resume function stores the stop point in memory and allows the player to play from where you stopped the player.

- 1 Switch RESUME to the ON position.



- 2 Press ■ STOP/CHARGE to stop the MD.

- 3 Press ► (play) to start play again.

Note

If you take the MD out or disconnect the power source (AC or battery power), the resume point will be lost.

Playing while walking or jogging

Use the Hold function to prevent the buttons from being accidentally operated while you are jogging, walking or charging the battery (see *Battery charging tips*).

Slide the HOLD switch in the direction of the arrow to activate the Hold function.



Battery charging tips

Use the HOLD function while charging
If a button is accidentally pressed while the battery is charging, charging will stop and "refreshing" will start again. To prevent this, slide the HOLD switch after the battery starts charging.

If you're in a hurry

If you don't want to wait for the battery to discharge completely ("refreshing"), you can interrupt the refreshing process and start charging immediately by pressing the ■ STOP/CHARGE button. However, we don't recommend you do this often with the same battery, since recharging a partially discharged battery weakens its capacity (i.e. it will operate for increasingly shorter periods).

To restore a weakened battery

If the battery capacity has been diminished considerably because of repeated partial rechargings, discharge and charge it a few times. This will restore the battery to full capacity. This also applies to when you use the battery for the first time or after a long period of disuse.

To remind yourself of the battery's charging state

Set the switch on the battery to the position where no mark is visible when the battery has finished charging. Set the switch to the red mark position when the battery has been discharged.

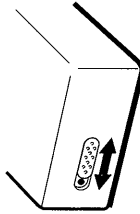

To best operate the battery

Keep the electrical contacts to the rechargeable battery compartment clean. If they are tarnished or dirty, battery operating time will decrease.

Precautions

On safety

- Since the laser beam used in this MiniDisc player is harmful to the eyes, do not attempt to disassemble the casing. Refer servicing to qualified personnel only.
- Do not put any foreign objects in the DC IN 10.5 V jack.

On power sources

- Use the rechargeable battery pack (supplied), house current or car battery.
- For use in your house: Use the AC power adaptor supplied with this player. Do not use any other AC power adaptor since it may cause the player to malfunction.
- The player is not disconnected from the AC power source (mains) as long as it is connected to the wall outlet, even if the player itself has been turned off.
- If you are not going to use this player for a long time, be sure to disconnect the power supply (AC power adaptor, rechargeable battery pack or car battery cord). To remove the AC power adaptor from the wall outlet, grasp the adaptor plug itself, never pull the cord.
- For use in the car: Use the CPA-4 car connection pack (not supplied).

On installation

- Never use the player where it will be subject to extremes of light, temperature, moisture or vibration.
- Never wrap the player in anything when it is being used with the AC power adaptor. Heat build-up in the player may cause a malfunction or injury.

On the headphones

- Do not use headphones while in traffic. Do not use headphones while driving, cycling, or operating any motorized vehicle. It may create a traffic hazard and is illegal in many areas. It can also be potentially dangerous to play your headset at high volume while walking, especially at pedestrian crossings. You should exercise extreme caution or discontinue using the headphones in potentially hazardous situations.
- Preventing hearing damage. Avoid using the headphones at high volume. Hearing experts advise against continuous, loud and extended play. If you experience a ringing in your ears, reduce the volume or discontinue use.
- Considering others. Keep the volume at a moderate level. This will allow you to hear outside sounds and to be considerate to the people around you.

On the MiniDisc cartridge

- Do not break open the shutter.
- Do not place the cartridge where it will be subject to light, temperature, moisture or dust.

On cleaning

- Clean the player casing with a soft cloth slightly moistened with water or a mild detergent solution. Do not use any type of abrasive pad, scouring powder or solvent such as alcohol or benzene as it may mar the finish of the casing.
- Wipe the disc cartridge with a dry cloth to remove dirt.

If you have any questions or problems concerning your player, please consult your nearest Sony dealer.

Troubleshooting

If you experience any of the following difficulties while using your player, use this troubleshooting guide to help you remedy the problem. If the

Symptom

Cause and/or Solution

- The player does not operate or operates poorly.**
- There's no disc in the player ("NO DISC" lights).
 - The HOLD switch has been slid in the direction of the arrow ("HOLD" lights).
 - Moisture has condensed inside the unit. Take the MD out and leave the player in a warm place for several hours until the moisture evaporates.
 - The AC power adaptor has not been plugged into the wall outlet.
 - The rechargeable battery is weak (⏻ flashes). (See *Charging the battery* in the section *Choosing power sources*.)
 - A blank disc has been inserted ("BLANK DISC" lights).
 - The disc is damaged ("DISC ERROR" lights).
- No sound comes through the headphones.**
- The headphones plug is not firmly connected to the Ⓜ jack.
 - Adjust the VOLUME control.
- Sound has a lot of static.**
- Strong magnetism from a television or such device is interfering with operations. Move away from the source of strong magnetism.
- The battery will not charge.**
- The rechargeable battery has been inserted incorrectly.
 - Insert the battery correctly.
 - The HOLD switch was slid in the direction of the arrow ("HOLD" lights) before you started charging. Slide the HOLD switch to the off position and press ■ STOP/CHARGE to start charging.

SECTION 2 DISASSEMBLY

NOTE: Follow the disassembly procedure in the numerical order given.

2-1. UPPER PANEL AND BOTTOM PANEL

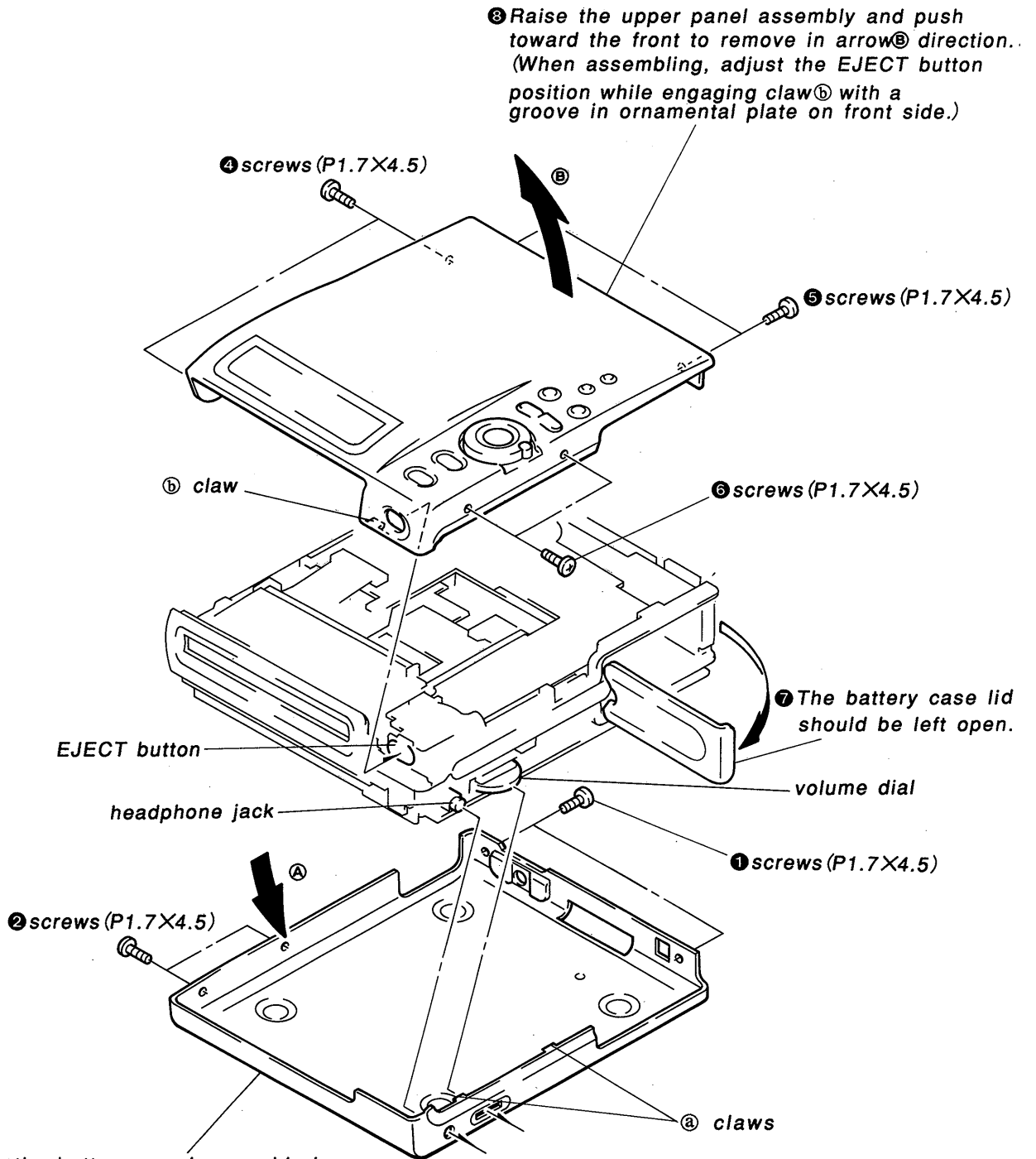

3 Remove the bottom panel assembly in arrow **A** direction. In such a case, push-in a little because claw **a** at two places gets stuck. (When assembling adjust the headphone jack and volume dial positions while engaging claw **a** at two places with each groove in ornamental plates on both sides.)

2-2. CONTROL BOARD

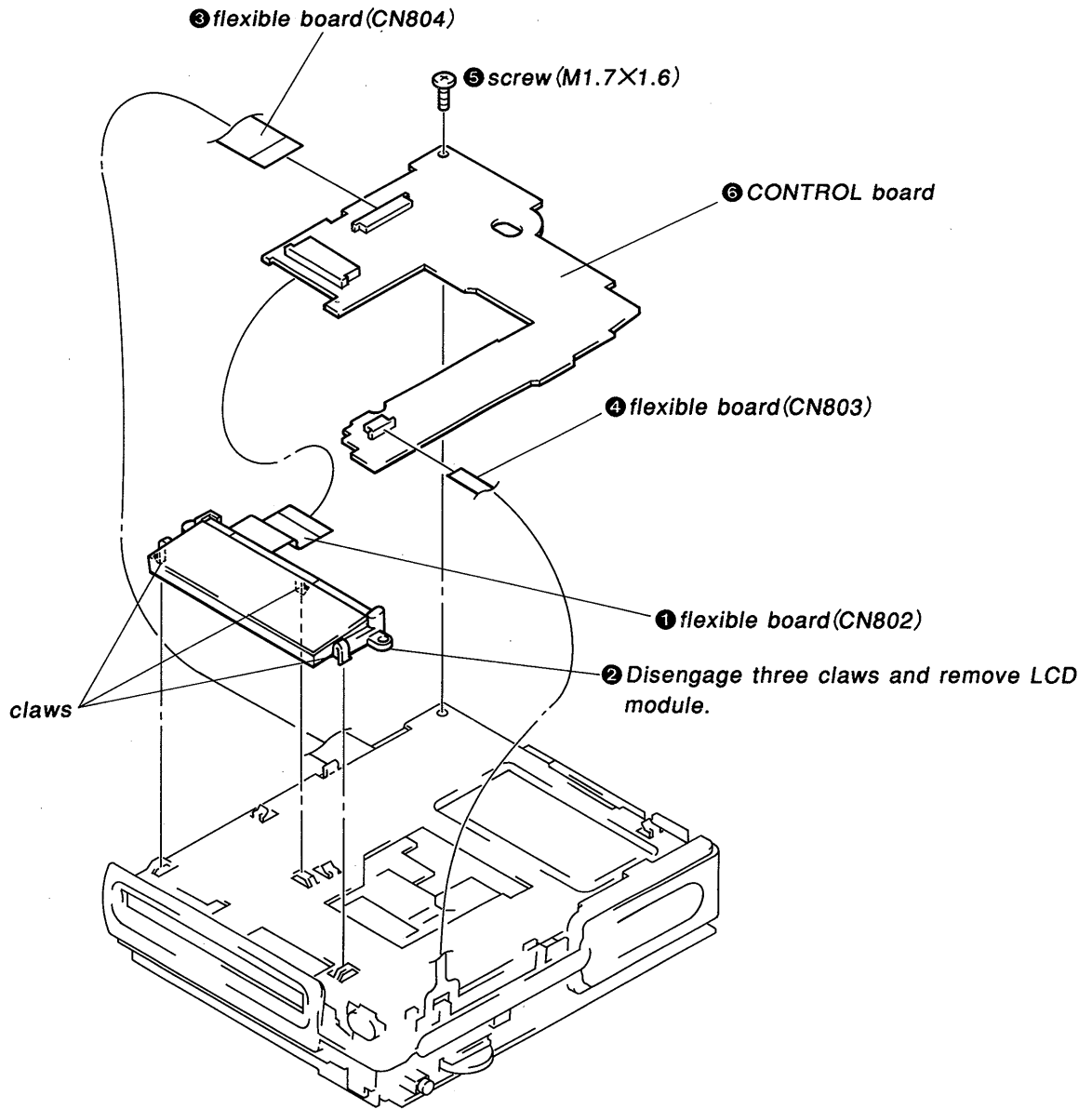

2-3. MAIN BOARD

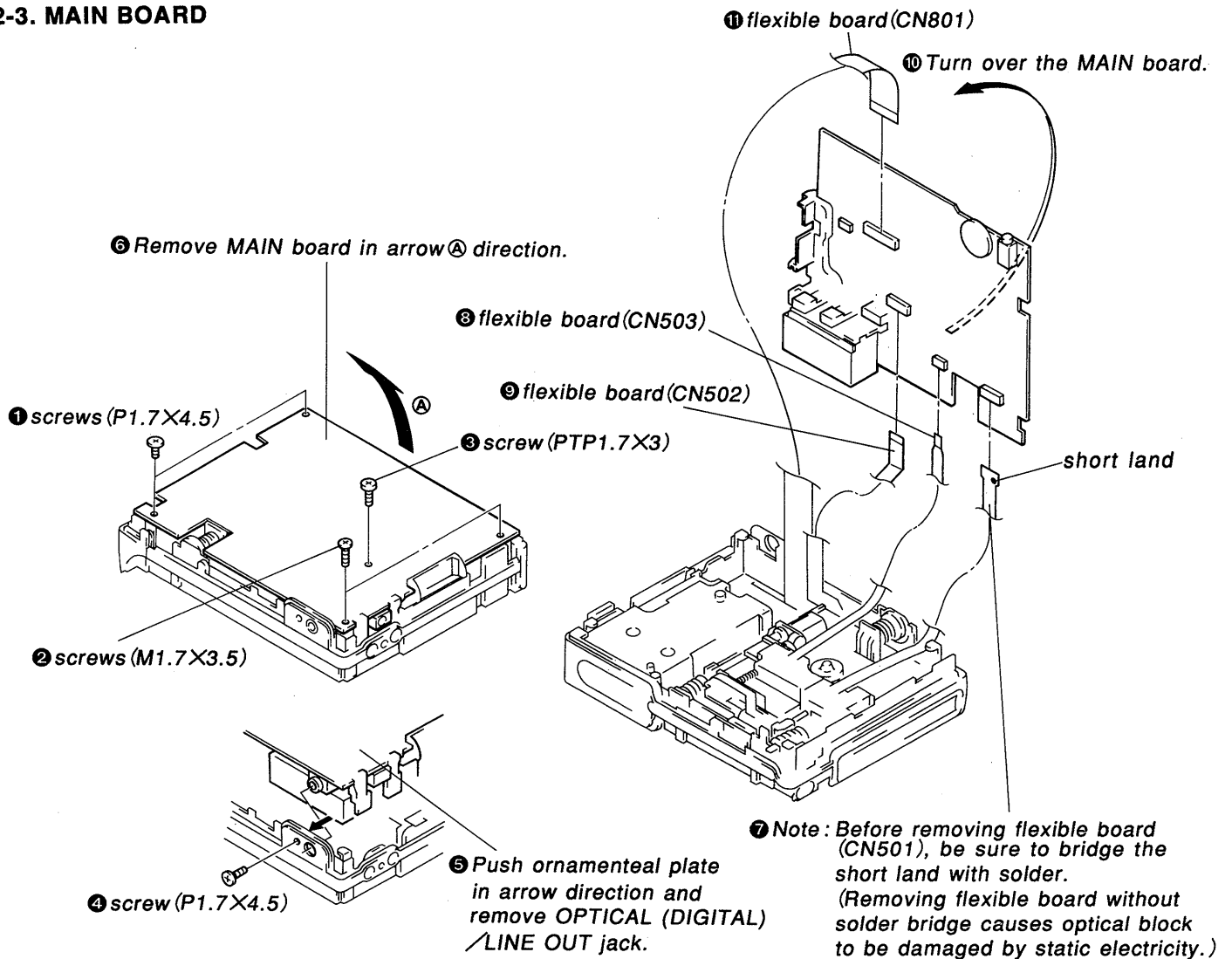

2-4. BATTERY CASE

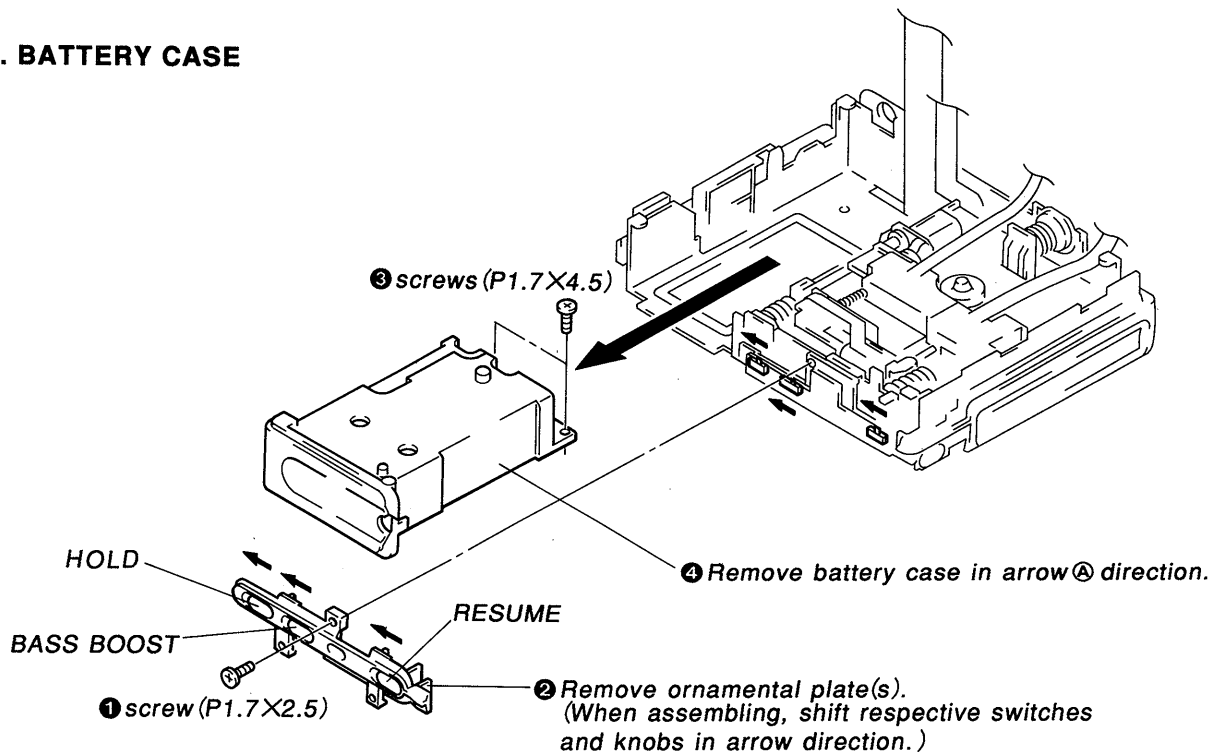

2-5. EJECT SHUTTER

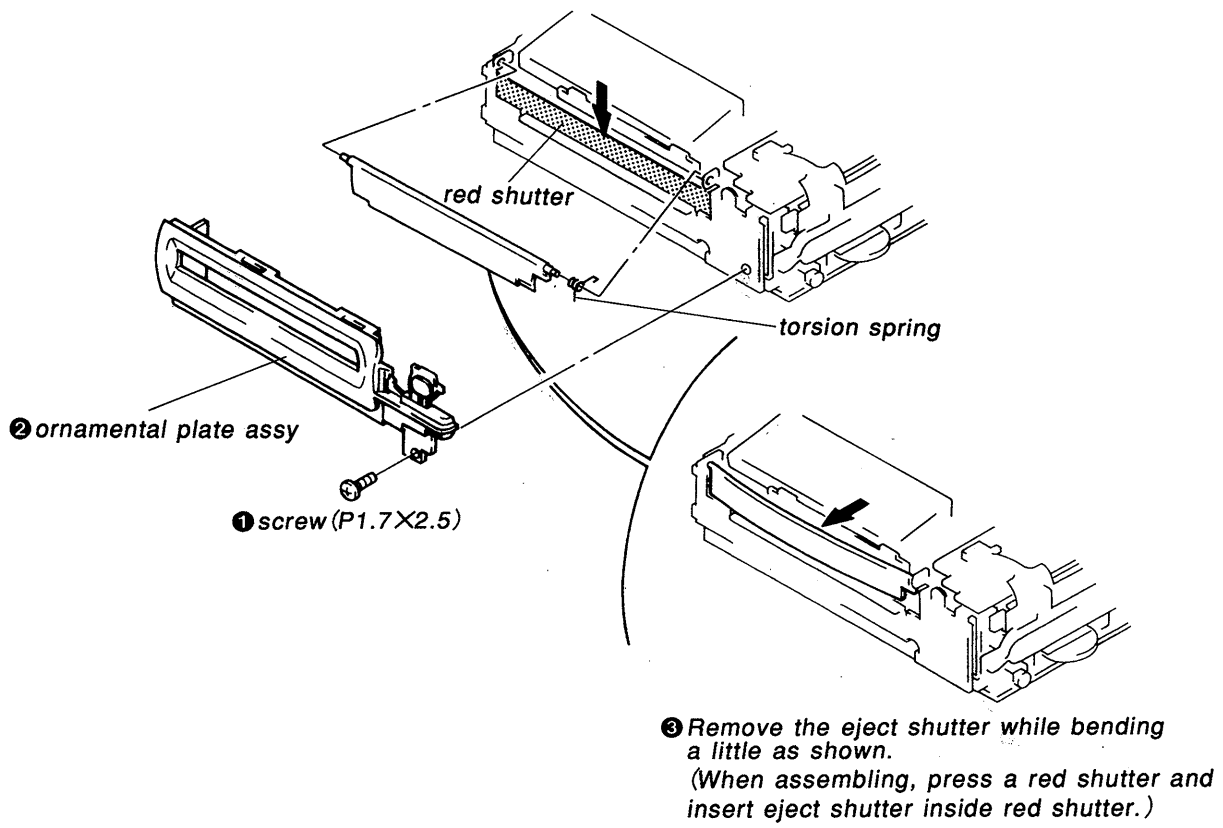

2-6. MECHANICAL DECK

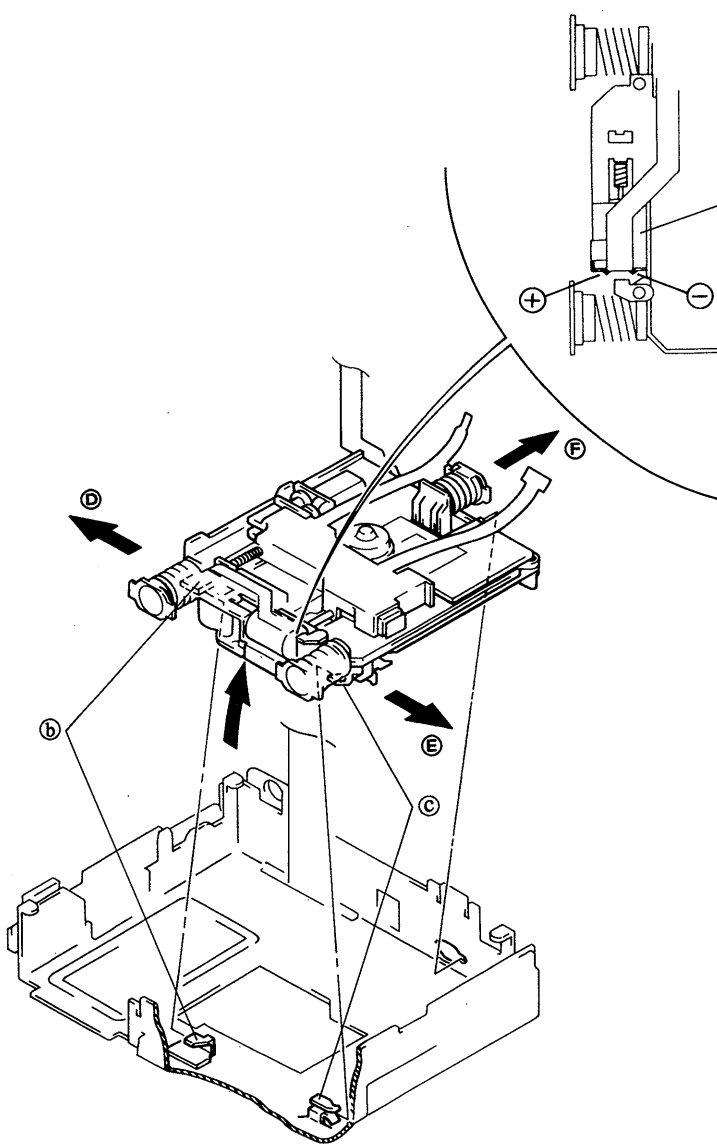

- ① Apply about 2V to loading motor terminals to activate the loading status.
- ② Disconnect the magnetic head connector (CONTROL board).

* If loading status is not activated due to faulty loading motor or a mechanical trouble. (This method, however, puts burden on mechanical components and therefore the mechanical deck should be removed in the loading status.)

1. Remove dampers at three places.
2. Shift mechanical deck in arrow (d) direction to unlock (b).
3. Shift mechanical deck in arrow (e) direction to unlock (c).
4. Shift mechanical deck in arrow (e) direction to remove.

- ④ Remove the mechanical deck from (b) and (c) sides where there are two dampers. (When assembling, remove a damper on (a) side and mount the chassis first, then the mechanical deck from (a) side.)

Note : Do not touch optical block if possible, when removing the mechanical deck.

Note : Run the loading motor to activate loading status when assembling the mechanical deck. (Mechanical deck will not be assembled unless the loading status is activated.)

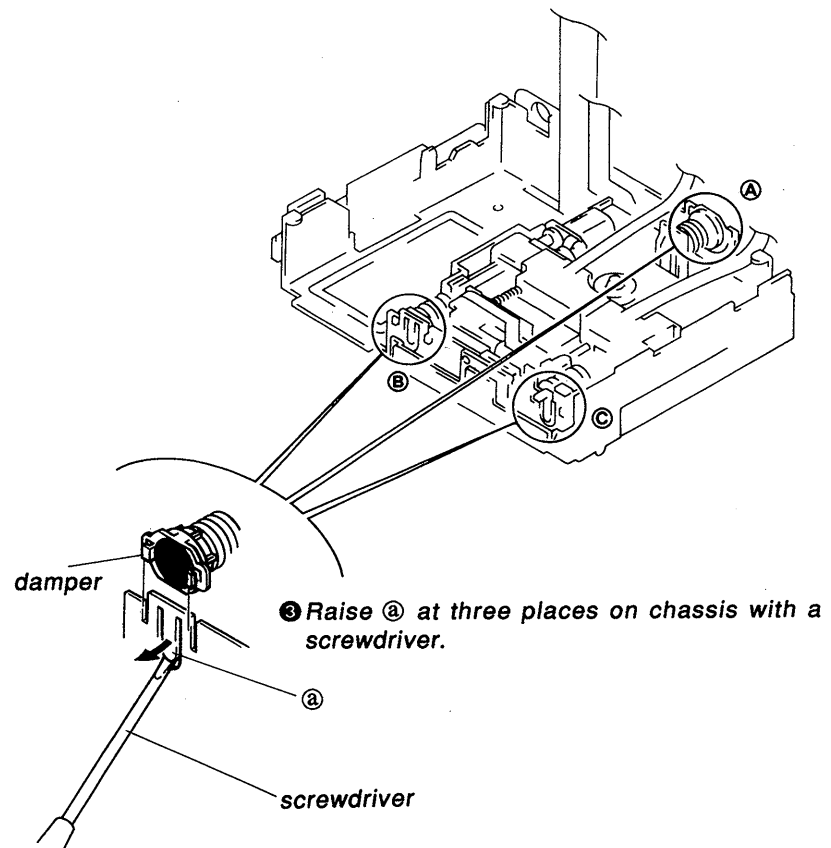

- ③ Raise (a) at three places on chassis with a screwdriver.

Note : When assembling mechanical deck, expand the lead edge of spring on vibration proof holder side to the position shown in figure.
(Thus, the mechanical deck balance will be suitable for ejection when the set is placed vertically.)

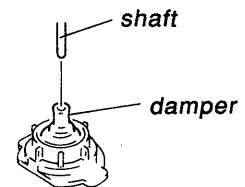
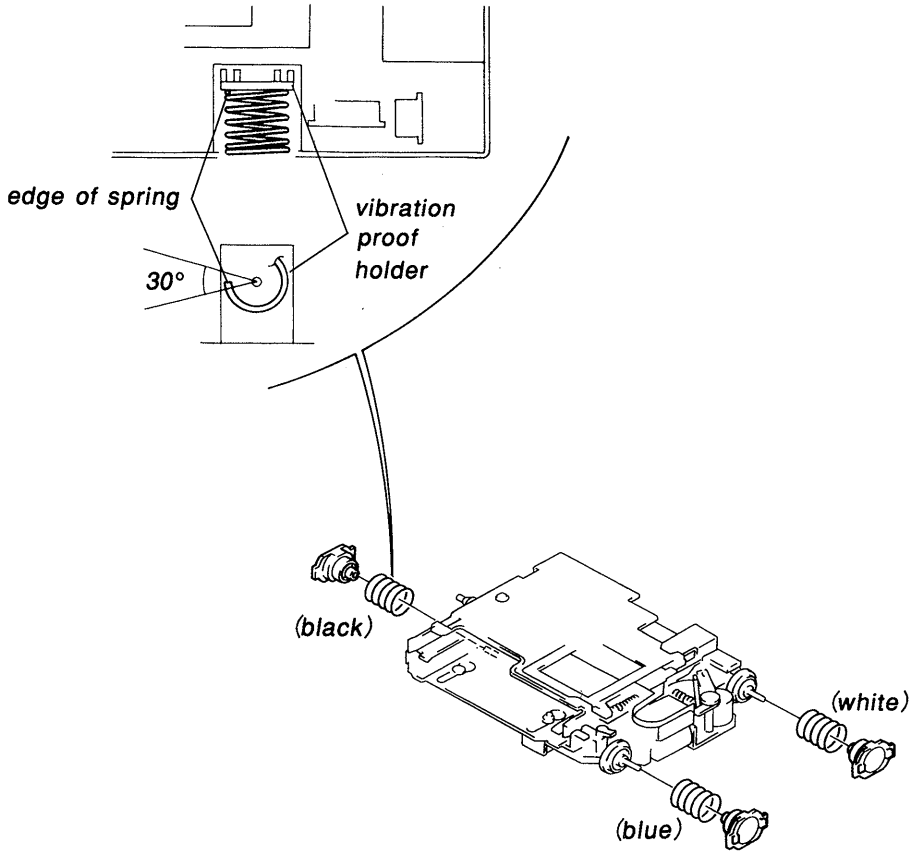

Note : When assembling a damper, insert the shaft with a lead edge peeled up as shown.

2-7. OPTICAL PICKUP BLOCK

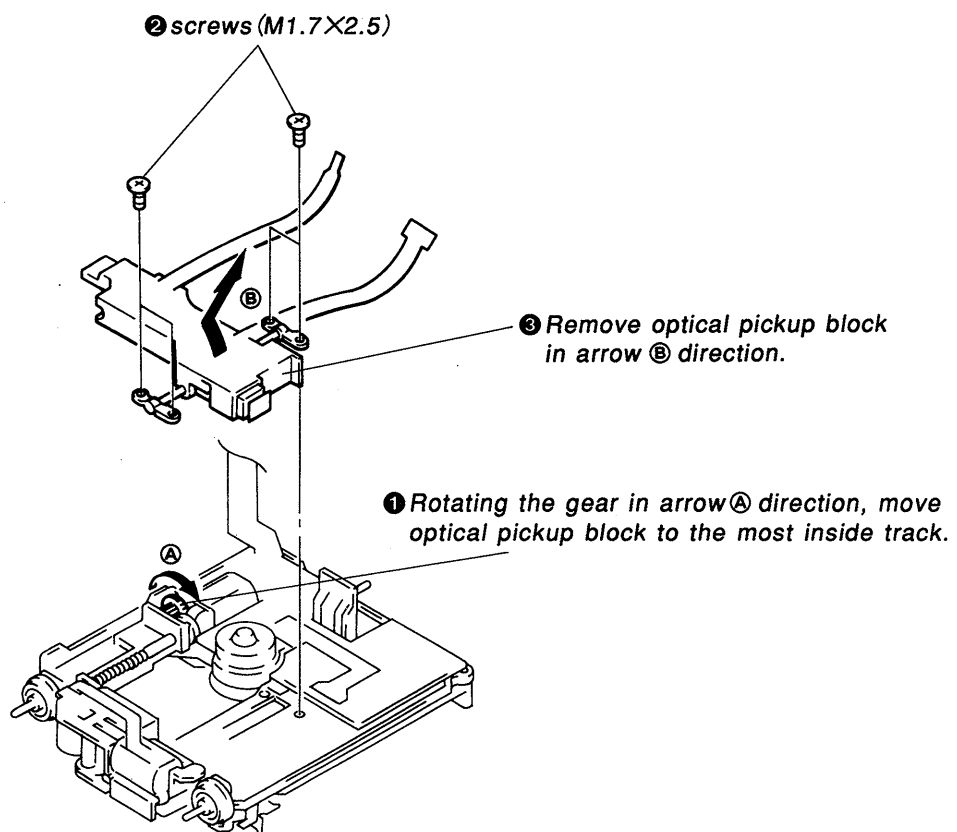

2-8. HOLDER ASSY AND MAIN SLIDER ASSY

1. Removal

⑤ Remove holder assy in arrow Ⓐ direction

① screw (M1.4X1.8)

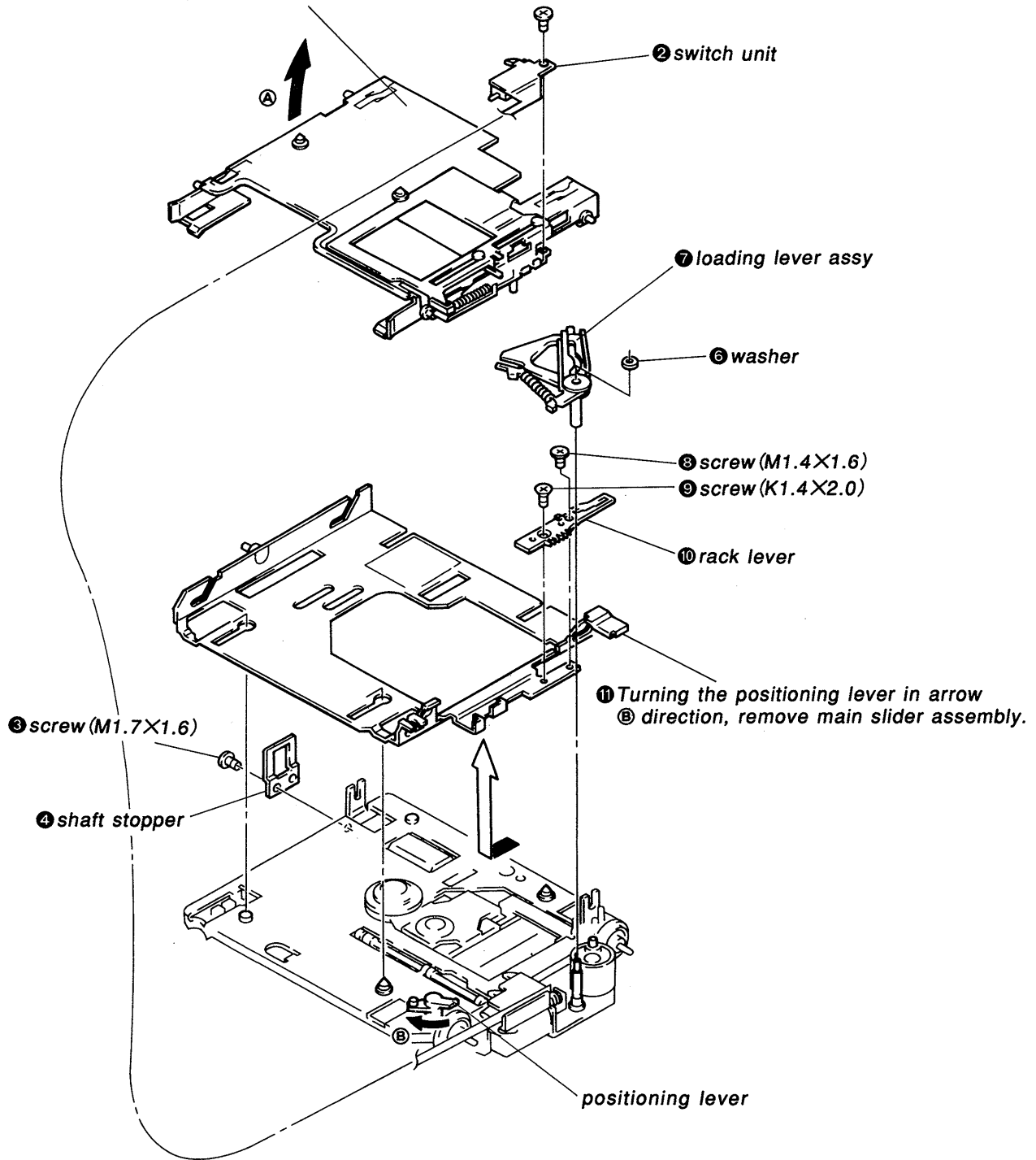

2. Assembling

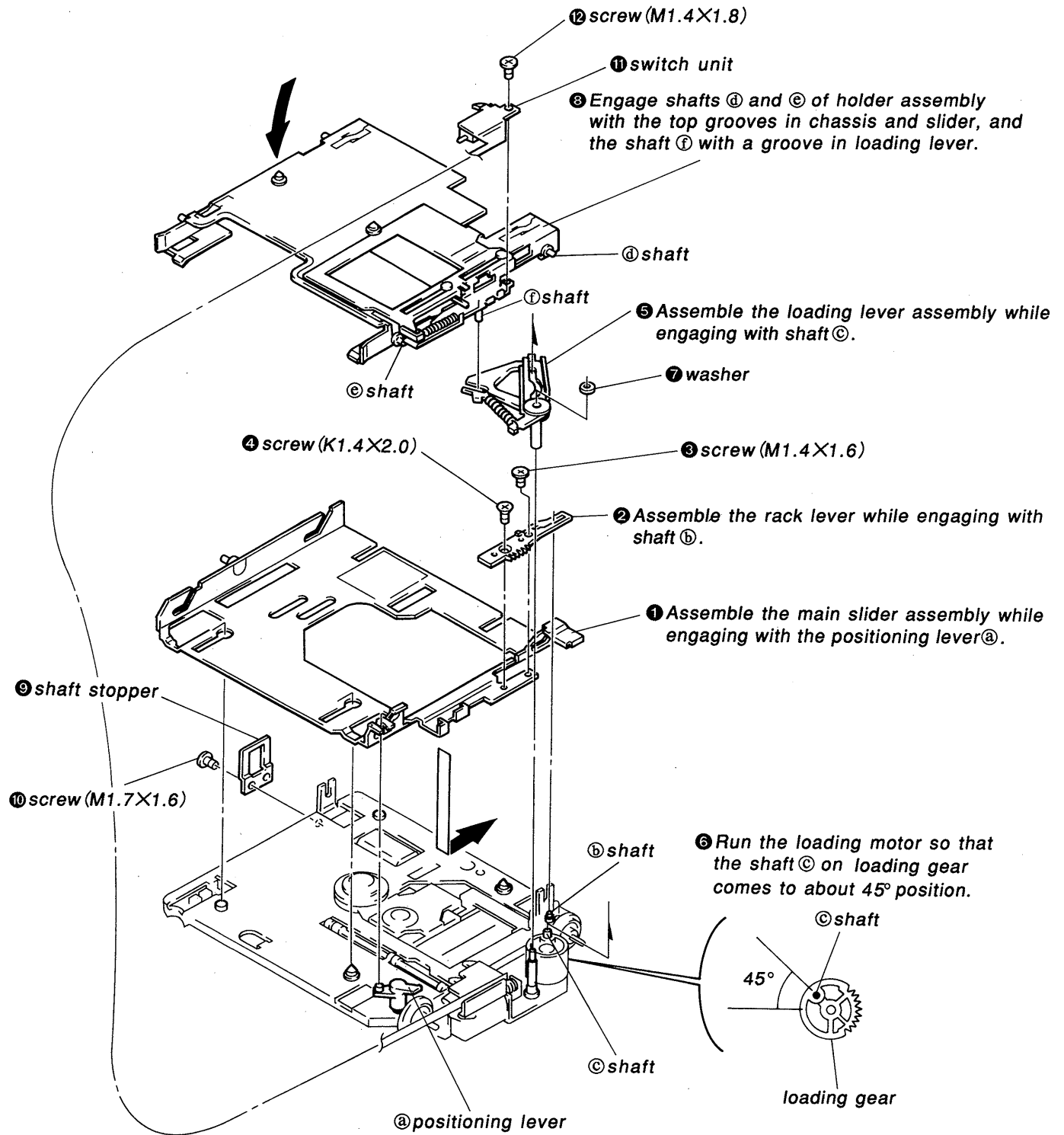

2-9. SLED MOTOR

Note : Assemble so that the printed face of motor is on the position shown in figure or the marking becomes ⊕.

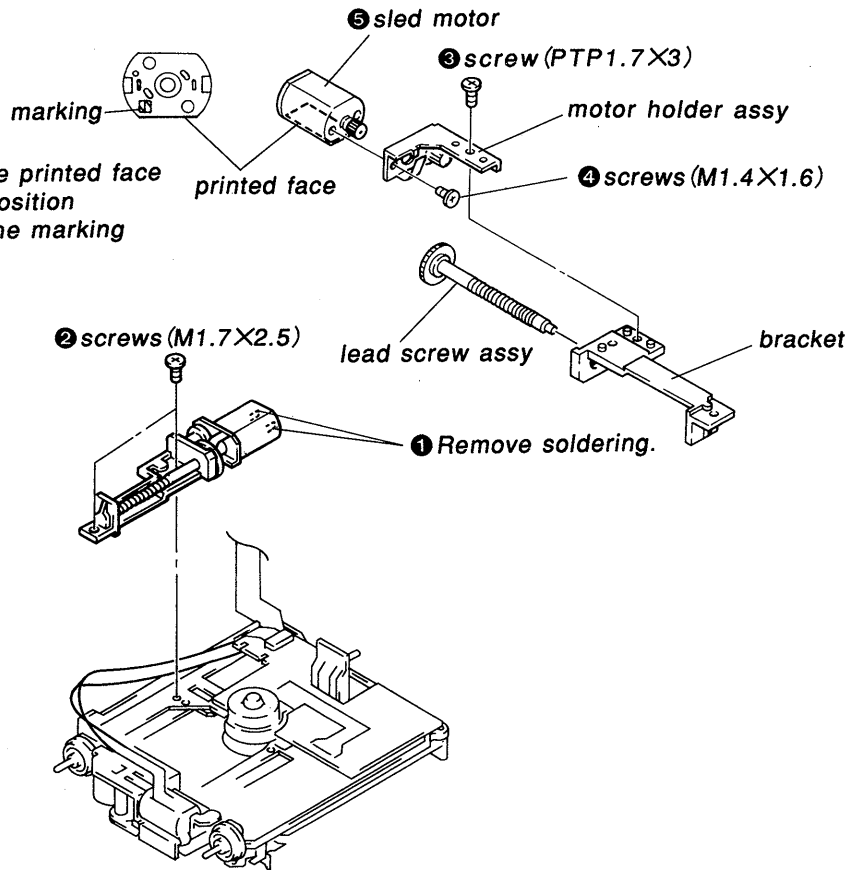

2-10. LOADING MOTOR

* Remove the holder assembly and loading lever assembly.

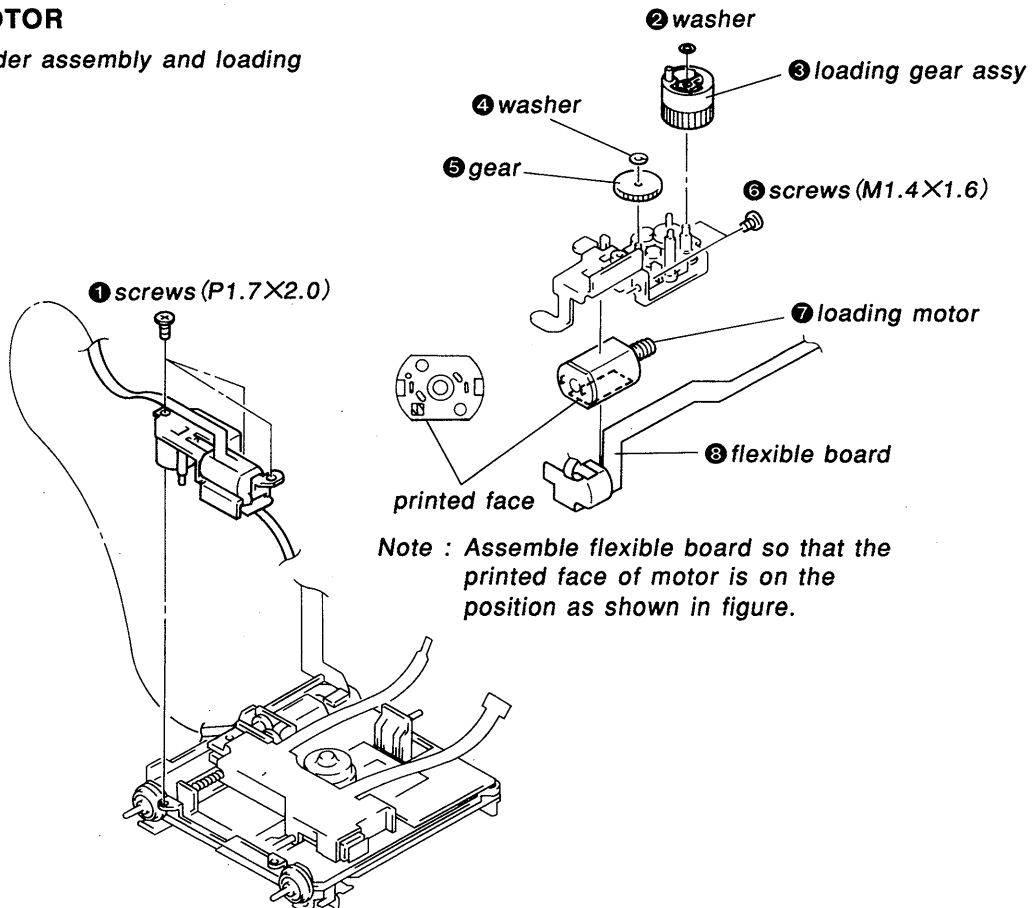

2-11. SPINDLE MOTOR

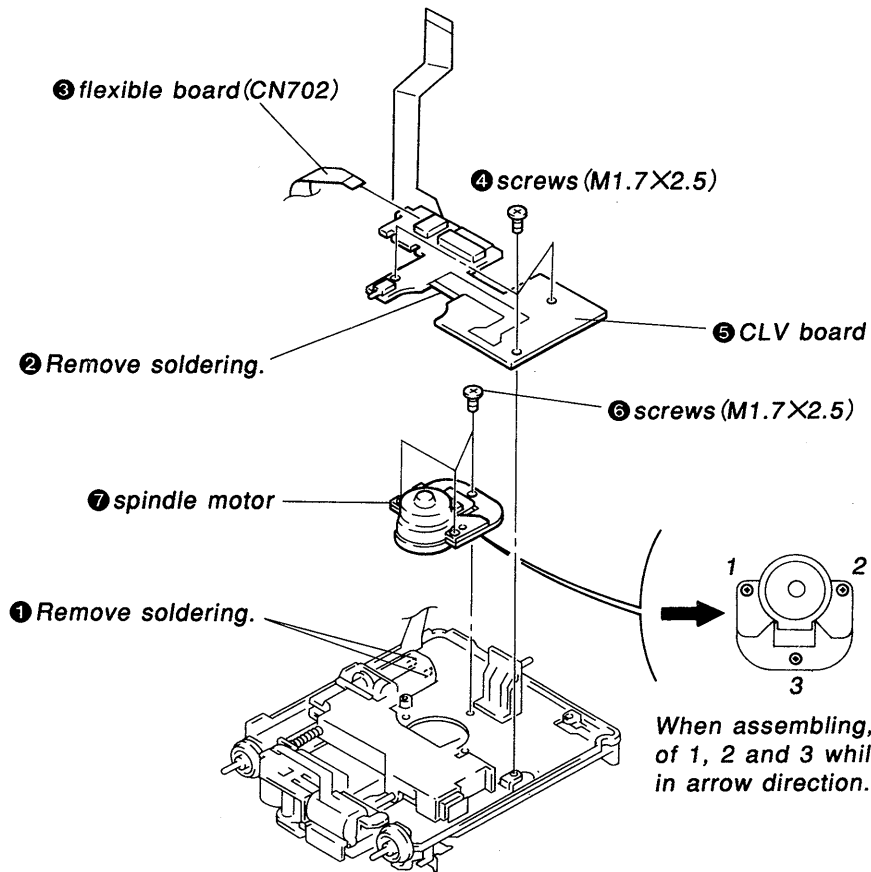

When assembling, tighten screws in the order of 1, 2 and 3 while shifting the spindle motor in arrow direction.

REVISED**SECTION 3
PIN FUNCTION****IC601 EFM/ACIR ENCODER/DECODER (CXD2525R)**

*In the I/O column, (3) implies state output and (A) implies analog output.

Pin. No.		Name	I/O	Function
QFP	VQFP			
1	79	FSW	O(3)	Spindle motor output filter switching output. "Z" in CLV-P mode, or "L" in other modes.
2	80	NON	O	Spindle motor ON/OFF control output. ON at "H".
3	1	MDP	O(3)	Spindle motor servo control
4	2	MDS	O(3)	Spindle motor servo control
5	3	EFMI	I	EFM input in PLAY mode
6	4	ASY	O	EFM full-swing output in PLAY mode
7	5	LOCK	O	Lock status monitoring of spindle servo (CLV). Lock at "H".
8	6	VCOO	O	EFM decoder analog PLL oscillation output (196Fs=8.6436MHz)
9	7	VCOI	I	EFM decoder analog PLL oscillation input
10	8	TEST1	I	Test pin. Normally GND.
11	9	PDO	O(3)	EFM decoder analog PLL phase comparison output
12	10	VSS	—	Digital GND
13	11	EFMO	O	EFM output in REC mode
14	12	ATER	O	ADIP CRC flag output. Error at "H".
15	13	CNIN	I	Track jump count signal input
16	14	SENS	O(3)	Internal status output to serial bus address
17	15	SYPL	I	SQSY, ADSY, DQSY, MQSY polarity switching input. Active high at "H".
18	16	FILO	O(A)	Master PLL filter output for digital PLL
19	17	FILI	I	Master PLL filter input for digital PLL
20	18	PCO	O(3)	Master PLL phase comparison output for digital PLL
21	19	AVSS	—	Analog GND
22	20	CLTV	I	Master PLL VCO control voltage input for digital PLL
23	21	AVDD	—	Analog power supply
24	22	XRST	I	System reset input. Active low.
25	23	REC	I	Decoder at "L". Encoder at "H".
26	24	TEST8	I	Test pin. Normally GND.
27	25	SCLK	I	Serial bus clock input
28	26	XLAT	I	Serial bus latch input
29	27	SWDT	I	Serial bus write data input
30	28	SRDT	O(3)	Serial bus read data output
31	29	ADSY	O	ADIP Sync output
32	30	SQSY	O	Subcode Q Sync output
33	31	VDD	—	Digital power supply
34	32	DQSY	O	Output of subcode Q Sync(SCOR) in digital IN U-bit CD format.
35	33	TEST7	O	Open this pin.
36	34	DTI	I	Audio signal input in REC mode
37	35	DTO	O(3)	Audio signal output in PLAY mode. High impedance in REC mode
38	36	C2PO	O	C2PO in PLAY, D. IN-VFLAG in D.REC, 0 in A. REC.
39	37	BCK	O	2.8224MHz output (MCLK system)
40	38	XBCK	O	BCK inverted output (MCLK system)
41	39	LRCK	O	44.1kHz (=Fs) (MCLK system)
42	40	WDCK	O	88.2kHz (MCLK system)
43	41	FS4	O	176.4kHz (MCLK system)

Pin. No.		Name	I/O	Function
QFP	VQFP			
44	42	GTOP	O	Sync guard window open at "H" (INPUT EFM SYNC monitor output)
45	43	XUGFS	O	Unguarded Frame Sync at "L" (INPUT EFM SYNC monitor output)
46	44	XPLCK	O	EFM decoder PLL clock output (98Fs=4.3218MHz)
47	45	GFS	O	Frame Sync OK at "H" (INPUT EFM SYNC monitor output)
48	46	EPDO	O(3)	EFM encoder external PLL phase comparison output Freq. : low → "H"
49	47	RFCK	O	7.35kHz output (MCLK system)
50	48	EVC I	I	EFM encoder external PLL oscillation input (196Fs=8.6436MHz)
51	49	EVCO	O	EFM encoder external PLL oscillation output (196Fs=8.6436MHz)
52	50	VSS	—	Digital GND
53	51	MCLK	O	22.5792MHz output. Duty is not guaranteed.
54	52	XTAI	I	Crystal oscillation input (512Fs=22.5792MHz)
55	53	XTAO	O	Crystal oscillation output (512Fs=22.5792MHz)
56	54	TEST9	I	Fix to "L"
57	55	MVCI	I	Digital IN PLL oscillation input (512Fs=22.5792MHz)
58	56	MVCO	O	Digital IN PLL oscillation output (512Fs=22.5792MHz)
59	57	TEST2	O	Fix to "open"
60	58	DIPD	O(3)	Digital IN PLL phase comparison output Freq. : low → "L"
61	59	RAOF	O	RAM overflow output (Decoder monitor output)
62	60	MT3	O	Correction status monitor output in PLAY mode
63	61	MT2	O	Correction status monitor output in PLAY mode
64	62	MT1	O	Correction status monitor output in PLAY mode
65	63	MT0	O	Correction status monitor output in PLAY mode
66	64	WFCK	O	7.35kHz (EFM decoder PLL system in PLAY mode, EFM encoder PLL system in REC mode)
67	65	DIN	I	Digital audio input pin
68	66	MD2	I	Digital audio OUT ON/OFF pin. ON at "H".
69	67	DOUT	O	Digital audio output pin
70	68	DIDT	O	Audio data output pin for digital audio input pin
71	69	DODT	I	16-bit data input pin for digital audio output
72	70	DOVF	I	Validity flag input pin for digital audio output
73	71	VDD	—	Digital power supply
74	72	TEST3	I	Fix to "L"
75	73	TEST4	O	Fix to "open"
76	74	TEST5	I	Fix to "L"
77	75	TEST6	I	Fix to "L"
78	76	FMCK	I	ADIP read clock input (TTL Schmidt input)
79	77	FMDT	I	ADIP data input (TTL Schmidt input)
80	78	ADFG	I	ADIP carrier signal input (TTL Schmidt input)

- Notes :
- XUGFS is Frame Sync taken from EFM signal and it is a negative pulse. It is a signal before Sync protection.
 - For the XPLCK, PLL is generated so that the inverted EFM PLL clock falling edge meets with the transition point of EFM signal.
 - GFS signal becomes "H" when Frame Sync meets with the internal guard timing.
 - C2PO signal indicates data error status.
 - RAOF signal is generated when 32kRAM exceeds $\pm 4F$ jitter margin.

IC602 SHOCK PROOF MEMORY CONTROLLER(CXD2526Q)

Pin. No.	Name	I/O	Function
1	A14	O	SRAM address bus A14 when RMSL=H, or WFFUL (note) when RMSL=L
2	A15	O	SRAM address bus A15 when RMSL=H, or RFEMP (note) when RMSL=L
3	A16	O	SRAM address bus A16 when RMSL=H, or WFOVF (note) when RMSL=L
4	A17	O	SRAM address bus A17 when RMSL=H, or WDTM (note) when RMSL=L
5	A18	O	SRAM address bus A18 when RMSL=H, or ZERO (note) when RMSL=L
6	A19	O	SRAM address bus A19 when RMSL=H, or MDTSC (note) when RMSL=L
7	A20	O	SRAM address bus A20 when RMSL=H, or CMPSY (note) when RMSL=L
8	LRCK	I	LRCK input from EFM encoder/decoder
9	BCK	I	BCK input from EFM encoder/decoder
10	C2PO	I	C2PO input from EFM decoder
11	DATA	I/O	I/O data from decoder in PLAY mode, or to encoder in REC mode
12	VSS	—	GND
13	TEST	I	Test pin. Normally fix to "L".
14	XRST	I	RESET input. Reset at "L".
15	MIN	I	External monitor signal input pin. Input a signal to be monitored.
16	SRDT	(HiZ) O	Microcomputer serial data output. Hi-z when CXD2526 read register is not selected.
17	SWDT	I	Microcomputer serial data input
18	XSLT	I	Microcomputer serial data latch signal input
19	SCK	I	Microcomputer serial data shift clock input
20	SCTX	I	Data output enable signal input in REC mode
21	RCPB	I	PLAY mode at "L"/REC mode at "H"
22	WRMN	I	WRITE mode at "H"/MONITOR mode at "L"
23	SBMN	I	Input signal recording based on SDCT at "H"/based on DCT at "L"
24	XINT	O	Interrupt request output. "L" in the interrupt status.
25	MDSY	O	Input data MD Sync detection signal
26	MEMFUL	O	H when main data area is full
27	MEMEMP	O	H when main data area is empty
28	UNDER	O	H when RMS < THUND
29	OVER	O	H when RMS ≥ THOVR
30	ERWR	O	H when C2PO data is written in RAM
31	BTOV4	O	H when BCT ≥ 400(Hex)
32	TXST	O	H during data transfer
33	VDD		System power supply
34	BUSY	I/O	H during RAM access
35	ZZ2	I	Test signal. Fix to "L".
36	ZZ1	I	Test signal. Fix to "L".
37	ZZ0	I	Test signal. Fix to "L".
38	XALT	O	Data ready or latch signal to CXD2527
39	ADT1	I	Data input from CXD2527
40	ADTO	O	Data output to CXD2527
41	ACK	O	Data I/O clock output to CXD2527
42	AC2	O	C2PO output pin for output data to CXD2527
43	XRQ	I	Data request signal input from CXD2527
44	SDCK	I	External subdata I/F shift clock input
45	SBDT	I/O	External subdata I/F data output in PLAY mode, or data input in REC mode
46	XWT	O	External subdata I/F wait signal. When this pin is "L", clock to read new data must not be fed.

Pin. No.	Name	I/O	Function
47	SRDY	O	External subdata I/F access permit signal. When this pin is "H", clock to read/write subdata is ignored, even if fed.
48	MCK	O	128Fs output
49	F256	O	256Fs output
50	XTLO	O	System clock output
51	XTLI	I	System clock input. Input 22.5792MHz.
52	VSS	—	GND
53	TEST	I	Fix to "L"
54	RMSL	I	External RAM selection. SRAM at "H"/DRAM at "L".
55	ERR	I/O	C2PO input/output when EXTC2R="H"
56	D7	O	SRAM data line D7 when RMSL="H"/Test signal at "L"
57	D4	I/O	RAM data bus D4 when RMSL="H"/Test signal at "L"
58	D0	I/O	RAM data bus D0
59	D1	I/O	RAM data bus D1
60	D3	I/O	RAM data bus D2
61	D2	I/O	RAM data bus D3
62	XCAS	I/O	DRAM $\overline{\text{CAS}}$ output when RMSL="L"/Data bus D5 when RMSL="H"
63	XOE	O	RAM output enable
64	A10	O	RAM address bus A10
65	XWE	O	RAM write enable
66	XRAS	I/O	DRAM $\overline{\text{RAS}}$ output when RMSL="L"/Data bus D5 when RMSL="H"
67	A11	O	RAM address bus A11
68	A9	O	RAM address bus A9
69	A0	O	RAM address bus A0
70	A1	O	RAM address bus A1
71	A2	O	RAM address bus A2
72	A3	O	RAM address bus A3
73	VDD	O	System power supply
74	A8	O	RAM address bus A8
75	A7	O	RAM address bus A7
76	A6	O	RAM address bus A6
77	A5	O	RAM address bus A5
78	A4	O	RAM address bus A4
79	A12	O	RAM address bus A12 when RMSL="H"/CS output at "L"
80	A13	O	RAM address bus A13 when RMSL="H"/SYOK output at "L"

Note : WFFUL "H" when the write FIFO is full.
 RFEMP "H" when the read FIFO is empty.
 WFOVF "H" when the write FIFO overflows.
 WDTM The timing for window in D1 block is output.
 ZERO "H" when BCT=0.
 MDTSC "H" when the header sector of input data is 00-1F, or "L" for others.
 CMPSY Internal synchronization timing.

SECTION 4 TEST MODE

The microcomputer of this set provides the TEST mode.

The following describes TEST mode function and its operating method.

[CAUTION ON LASER EMISSION]

Never look into the laser unit from top position when confirming laser emission during adjustment. Otherwise, you could lose your eyesight.

[CAUTION in TEST mode]

- Pressing ENTER key with all servo ON erases the contents of disc(UTOOC erasing).
- Confirm RF waveform since no playback signal is output during playback in the TEST mode.

[Activation or deactivation of TEST mode]

1. With an AC cord unplugged and battery removed, short JR106 with solder jumper.
2. Plug—in the AC cord, and the TEST mode will be activated.
3. To deactivate the TEST mode, remove the solder jumper.

[Checking RF waveform]

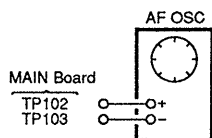

1. Place the set in STOP status, and connect an oscilloscope to TP102.
2. Select either CLV servo mode of "a" to "d" listed in Table 1 on page 29, and load a suitable disc(MO should have been already written).
3. Press the PLAY key, and RF waveform will be output.
4. Check that proper waveforms are output in all modes "a" to "d" listed in Table 1.

RF signal Waveform

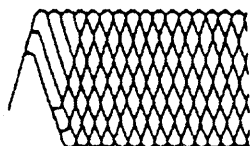

[Operation in TEST mode]

1. Output of SIN wave
 - 1-1. After power ON initialization, the SIN wave of 1KHz — 12dB is output from LINE OUT and PHONE, which will be continuously output until any key is pressed(but, this operation is only performed immediately after power ON).
 - 1-2. The audio circuit will be normal if this signal is output.

* The 212—byte data is transferred from IC801 (microcomputer)to IC602 and IC602 generates a fixed pattern.

2. Checking loading operation of cassette compartment
 - 2-1. Loading is started when caddy is inserted.
 - 2-2. The caddy is ejected when EJECT key is pressed.
 - 2-3. The head is moved up and down when pressing PAUSE key with an MO disc loaded. (Do not use CD disc.)

* Unplug the power cord immediately when you find any abnormality because the cassette compartment keeps operating by ignoring mechanical failure.

3. Checking servo system

- 3-1. Checking laser emission
 - 3-1-1. Confirm that repetitional operation of laser beam emission and lens up—down movement is performed when pressing the PLAY key without loading a disc.
 - 3-2. Focus search and CLV is kicked up to rough servo
 - 3-2-1. Load a disc and press the PLAY key in STOP status.
 - 3-2-2. Focus search, Focus on and CLV—A are executed.
 - 3-2-3. Disc reflection is checked, and the laser power is set to MO/CD READ power.
 - 3-2-4. Tracking brake is turned on.
 - 3-3. All servo ON
 - 3-3-1. With the set in STOP status or during servo system check 3-2, press PLAY key.
 - 3-3-2. Focus on, CLV—A, sled motor and tracking motor are turned on respectively.

- 3-4. Movement of optical pickup
 - 3-4-1. With the set in STOP status or during servo system check 3-1, 3-2, 3-3, press NEXT key.
 - 3-4-2. The sled motor and tracking run forward while the NEXT key is pressed.
 - 3-4-3. With the set in STOP status or during servo system check 3-1, 3-2, 3-3, press PREV key.
 - 3-4-4. The sled motor and tracking reverse while the PREV key is pressed.
 - 3-4-5. Check for smooth operation.
- 3-5. All servo OFF
 - 3-5-1. With the set in STOP status or during servo system check 3-1, 3-2, 3-3, press STOP key.
 - 3-5-2. Focus on, CLV – A, sled motor and tracking motor are turned off respectively one by one.

4. Switching laser power

- 4-1. With the set in STOP status, press EDIT key.
- 4-2. Each time the EDIT key is pressed, laser power varies like : [CD-READ] → [MO-READ] → [3.5mW] → [OFF] ([Laser CD PIT] → [Laser MO GRV] → [Laser1/2 GRV] → [Laser OFF PIT])

Remarks : In the CD/MO READ power mode, the module is turned on about 10ms after the laser is turned on.

* Use for READ power checking.

5. Selection of CLV servo mode

- 5-1. With the set in STOP status, press PLAY key and PLAY MODE key, so that each mode is selected depending on setting of REFLECT, RESUME and HOLD switches as shown in Table 2.

Table 1

Mode	Operation			Applicable disc	LCD DISPLAY	CLV mode
	REF.	RESUME	HOLD	Applicable area	PIT/GRV	
a	L	ON	HOLD	CD:PIT	PIT	EFM
b	H	ON	HOLD	MO:PIT	GRV	EFM
c	H	OFF	HOLD	MO:Recorded	GRV	EFM
d	H	OFF	OFF	MO:Groove	GRV	ADIP

- * Always use a disc suitable for each mode.
- * REF. is automatically changed over when caddy is loaded, It is in "H" status when caddy is not loaded, or in "L" status when TP520 is connected to GND.
- * In mode "b", optical pickup must be positioned on the most inside track.
- * In mode "c" and "d", move optical pickup to proper Groove area.

6. Linking data recording (for adjusting focus bias)

- * This is how to make in case of MZ-1.
- * This disc has been registered as a service tool.
- * Prepare for focus bias adjustment because it takes about 20 minutes to complete this operation.
- 6-1. Load an MO disc and press REC key(no IN terminal is connected : Analog recording).
- 6-2. Move optical pickup to a proper position in Groove area.
- 6-3. Press PLAY key, PLAY MODE key, "O" key and REC key, and the pickup makes an access to 0032 cluster.
- 6-4. Perform linking recording over 0700. cluster display (for about 20 minutes), then stop by pressing the STOP key.

7. LCD display

- POWER ON '■■■■■■■' (ALL on)
 - (POWER ON & 'Welcome to Disc World' (Continuous scroll)
 - LOAD/EJECT) ' {SONY} '
 - 1st line
 - PLAY KEY 'Focus Srch'
 - 'Focus ON !'
 - STOP KEY 'ALL SV OFF'
 - P MODE KEY 'ALL SV ON'
 - NEXT KEY 'T. SLED FWD'
 - PREV KEY 'T. SLED RVS'
 - 2nd line
 - EDIT KEY 'Laser OFF PIT'
 - 'laser CD PIT'
 - 'laser MO GRV'
 - 'laser 1/2 GRV'
 - P MODE KEY 'xxxxC xxS'
 - 'Error-xxxx'
- Displayed alternately with DATE key.
Cluster (error) is displayed at All servo on.

SECTION 5 ELECTRICAL ADJUSTMENTS

[Notes]

1. Adjust all items in the listed order (up to (1-8) when optical pickup is replaced).
2. Power supply voltage : DC10. 5V
3. Use a disc (MO or CD) suitable for the CLV servo mode, whenever so specified.
4. Place the set in TEST mode before adjustment (see page 2) and reset the mode after adjustment.
5. Short the laser taps on flexible board with solder during removal and mounting, because optical pickup could easily be broken by static electricity.

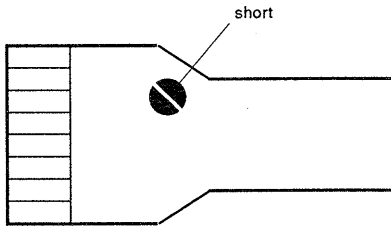

optical pickup flexible board

[Before adjustment]

Place the set in TEST mode, and perform operation check in TEST mode and confirm the following items.

1. Checking power supply

- 1-1. In the TEST mode, check that each output voltage satisfies standard value (in this set, no adjustment can be made because of parts layout, and therefore replace the unit if power supply is faulty).

	Standard value	
UPV	6. 5V±0. 5	TP405
CPUV	4. 0V±0. 15	TP841
4. 5	4. 5±0. 2	TP402
VP	5. 5±0. 2	TP404
4. 1	4. 1V±0. 1	TP401
4. 75	4. 75V±0. 2	TP403
10	8. 7V±0. 2	TP1

[Adjustment]

1-1. Adjustment of temperature compensation

1. With the set in cold status, measure voltage at TP120.
2. Calculate voltage based on the room temperature, then adjust RV509 meeting that value.

Remarks : 1) Compensated voltage will vary in a step of $-9\text{mV}/\text{deg}$ (voltage lowers by 9mV when room temperature rises 1°C) on the basis of voltage at TP120 at room temperature 25°C (VC=0V).

Remarks : 2) Temperature sensor : Q512(on operation board)

* Some of the following adjustments use both CD (PIT) and MO(PIT/Groove)discs. In such a case, switch the CLV servo mode by referring to page.

* In order to activate REF-L (Table 1 - a) without using a disc (CD status), TP520 must be shorted to GND.

1-2. Adjustment of focus offset

1. Place the set in STOP status (disc must be removed).
2. Short TP105 to VC(TP101).
3. Adjust RV511 in PIT mode (Table 1 - a), or RV510 in Groove mode (Table 1 - d) so that the voltage at TP107 is $\text{VC} \pm 50\text{mV}$.
4. Remove a short between TP105 and VC.

1-3. Adjustment of FOK offset

1. Place the set in STOP status (disc must be removed).
2. Adjust RV512 in PIT mode (Table 1 - a), or RV513 in Groove mode (Table 1 - d) so that the voltage at TP103 is $\text{VC} \pm 50\text{mV}$.

1-4. Adjustment of tracking error

1-4-1. Up to last digit—12 of main board

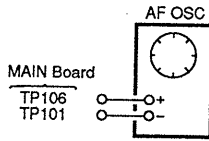

1. Activate MO-PIT, EFM-CLV mode (Table 1 - b).
2. In the STOP status, adjust RV504 so that the voltage at TP106 is $VC \pm 50mV$.
3. Load an MO disc and optical pickup moves to the most inside track, then press the PLAY key.
4. Connect an oscilloscope to TP106, and adjust RV504 so that a waveform at TP106 is vertically symmetric (noise measures).
5. Press the STOP key and switch the mode to CD-PIT, EFM-CLV (Table 1 - a). (Connect TP520 to GND with a jumper wire)
6. In the STOP status, adjust RV503 so that the voltage at TP106 is $VC \pm 50mV$.
7. Load a CD disc, and press PLAY key and adjust RV502 so that a waveform at TP106 is vertically symmetried against VC.
8. Remove a jumper wire between TP520 and GND.

1-4-2. Up to last digit -13 of main board

1. Place MO in PIT status and EFM in CLV status (Table 1 - b).
2. In the STOP status, adjust RV502 so that TP106 voltage becomes $VC \pm 50mV$.
3. Load an MO disc, move the optical pickup to the most inside track of disc, and press the PLAY key.
4. Connect an oscilloscope to TP106, and adjust RV501 so that a waveform at TP106 becomes vertically symmetric against VC.
5. Press the STOP key, move optical pickup to a middle track of disc, place MO in GRV status and ADIP in CLV status (Table 1 - d), and press the PLAY key.
6. Adjust RV504 so that a waveform at TP106 becomes vertically symmetric against VC.
7. Press the STOP key, and unload an MO disc.

8. Place CD in PIT status and EFM in CLV status (Table 1 - a).

9. Load a CD disc, and press the PLAY key.
10. Adjust RV503 so that a waveform at TP106 becomes vertically symmetric against VC.

1-5. Adjustment of focus bias

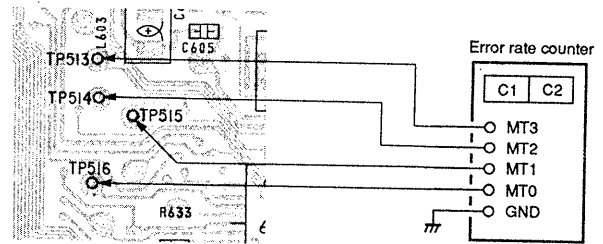

1. Load an MO disc on which the linking data recording as described on page 29 was executed, and press PLAY key on inside track in Groove area, then the PLAY MODE key. (Table 1 - d)
2. Adjust RV508 to search a point where the error rate (C1) is about 100 or 200, then press STOP key.
3. Record voltage at TP107.
4. Again perform playback and adjust RV508 in reverse direction of step 2) to search a point where the error rate (C1) is about 100 or 200, then press STOP key.
5. Record voltage at TP107.
6. Adjust RV508 so that the voltage at TP107 is intermediate value of those measured in steps 3) and 5).

1-6. Adjustment of CD read power

1. Load a CD disc.
2. Turn on the HOLD and RESUME switch (Servo=PIT, CLV=EFM). (See Table 1 - a)
3. Press the PLAY key, then the PLAY MODE key.
4. Adjust RV519 (on MAIN F board) so that the RF amplitude (at TP102) is $1.0V \pm 0.1$.

1-7. Adjustment of focus gain

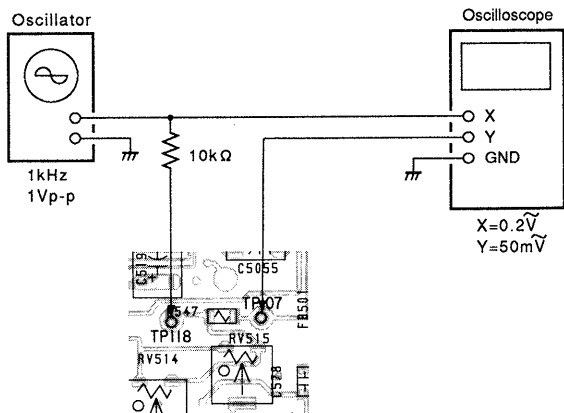

1. Load a disc(CD/MO), and press the PLAY key, then PLAY MODE key.
2. Enter 1kHz 1Vpp from oscillator to TP118 through 10kΩ.
3. Draw Lissajous' figure on oscilloscope with the oscillator output assumed as X axis and TP107 output as Y axis.
4. Adjust on the oscilloscope so as to attain the status (a=b) shown in Fig. 1.
5. Adjust each RV so that phase difference is 95 ± 5 deg (Fig. 1).

For CD (Table 1 - a) : RV515

For MO (Table 1 - d) : RV514

1-8. Adjustment of tracking gain

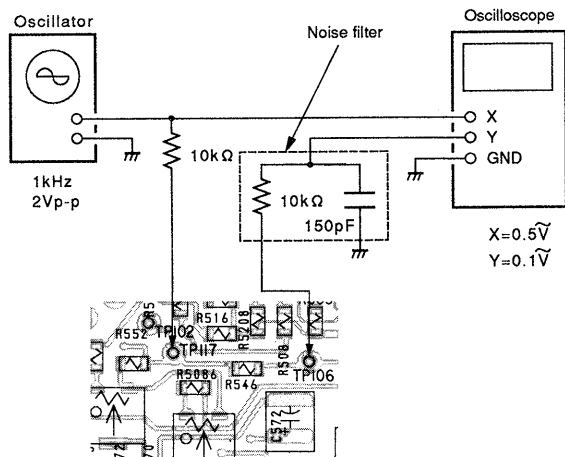

1. Load a disc(CD/MO), and press the PLAY KEY, then PLAY MODE key.
2. Enter 1kHz 2Vpp from oscillator to TP117 through 10kΩ.
3. Draw Lissajous' figure on oscilloscope with the oscillator output assumed as X axis and TP106 output as Y axis.
4. Adjust on the oscilloscope so as to attain the status (a=b) shown in Fig. 2.
5. Adjust each RV so that phase difference is 100 ± 5 deg (Fig. 2).

For CD (Table 1 - a) : RV516

For MO (Table 1 - d) : RV517

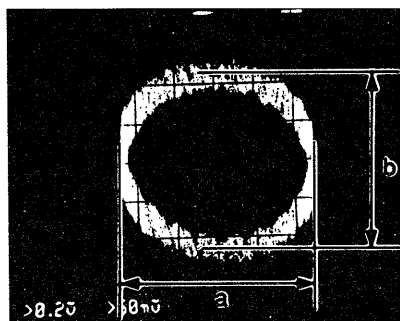

Fig. 1 Focus gain adjustment (95 deg)

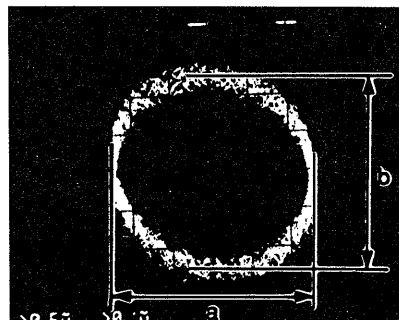

Fig. 2 Tracking gain adjustment (100 deg : inserting noise filter)

REVISED

1-9. Charging Operation Check

- Supply 10.5V to DC jack from external power supply connected with an ammeter while pressing the DATE (DISPLAY MODE) key to activate the POWER SUPPLY TEST mode. At this time, the "スタンバイ" is displayed on the screen.
- Press the DATE key 5 times to display "チャージ".
- Insert a battery which is not charged fully. The ammeter indicates between 0.8 and 1.0A.
- Press the PLAY key once to activate the CHARGE OPERATION CHECK mode. (Display will not change.)
- Confirm that the ammeter indicates between 0.8 and 1.0A. (Confirming charging voltage control circuit)
- Lower the power supply voltage to 8V. The ammeter indicates about 0.4A.
- Confirm that the set completes charging operation in about 30 seconds, then the "スタンバイ" is displayed. (Confirming completion of charging operation)

Note: Pressing the PLAY key twice causes the CHARGE OPERATION CHECK mode to be returned to POWER SUPPLY TEST mode. Therefore, the PLAY key must be pressed only once.

* The jigs for MZ-2P have been registered.
LIST OF MZ-2P JIGS

- TEST DISC (CD: Optical Disc)
TGYS-1 P/N : 4-959-188-01
- TEST DISC (MO : Magnet Optical Disc)
PTDM-1 P/N : J-2501-054-A
※ Linking data already registered
- ERROR RATE COUNTER
MDPE-1 P/N : J-2501-047-A

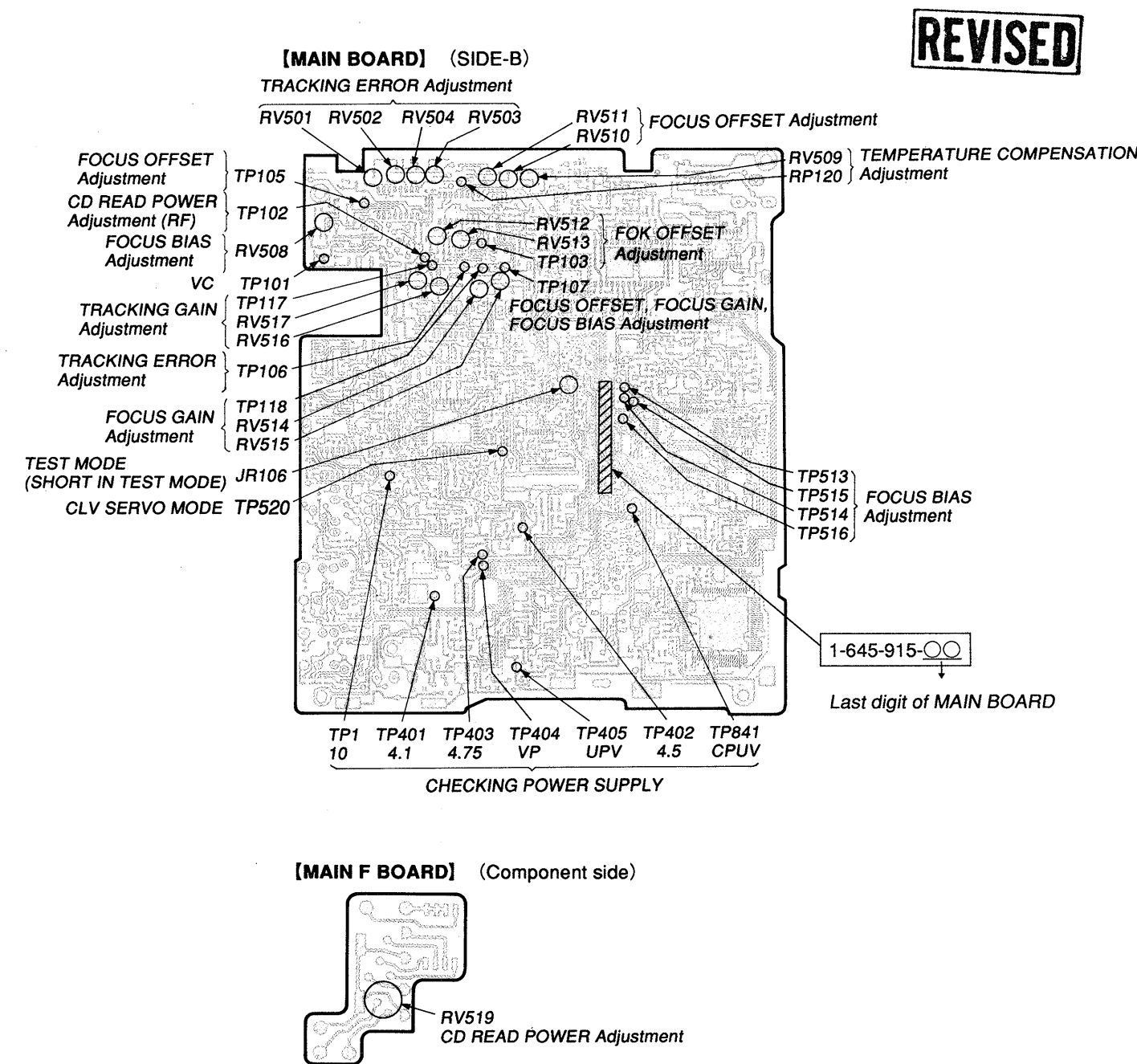

REVISED

**SECTION 6
DIAGRAMS**

6-1. BLOCK DIAGRAM

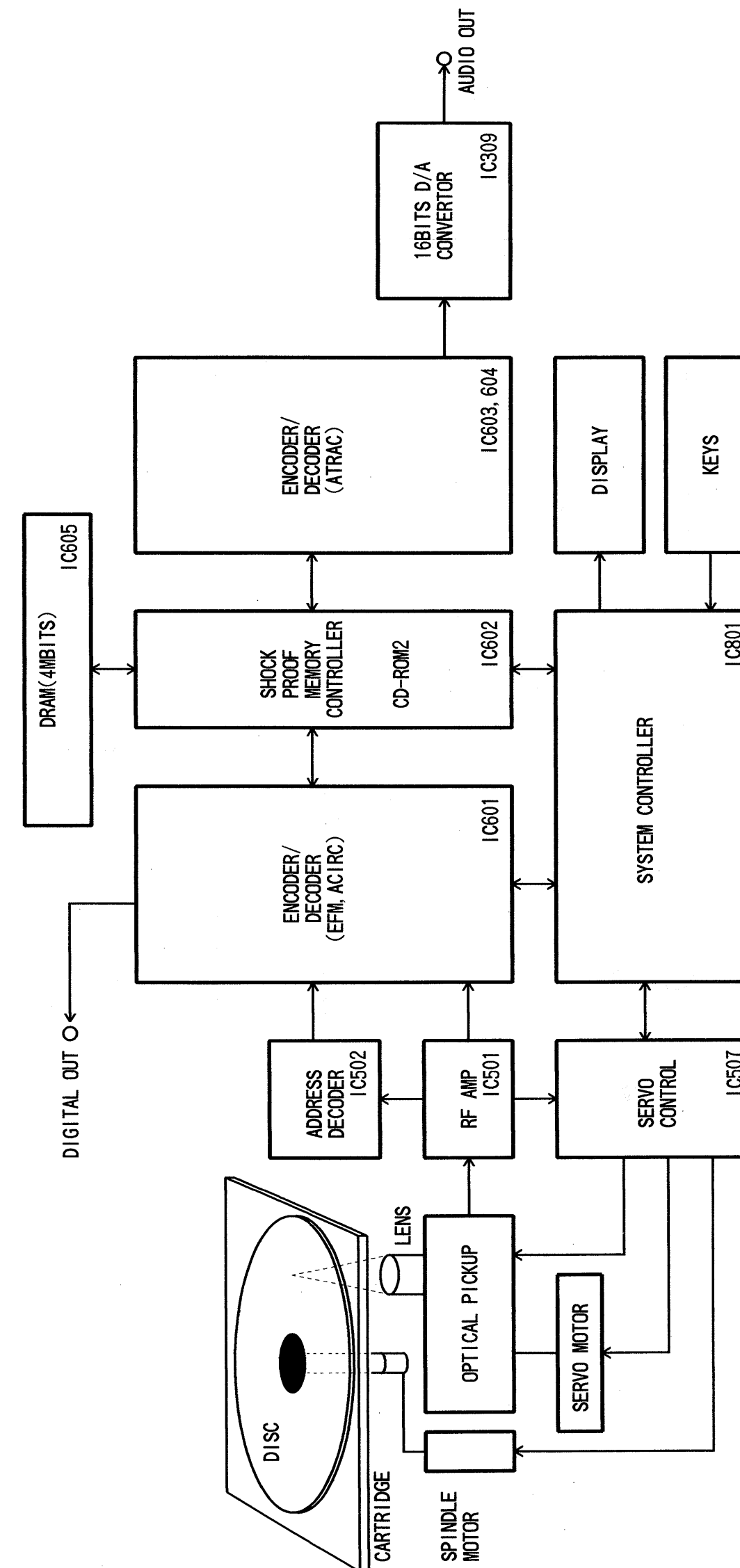

6-2. CIRCUIT BOARDS LOCATION

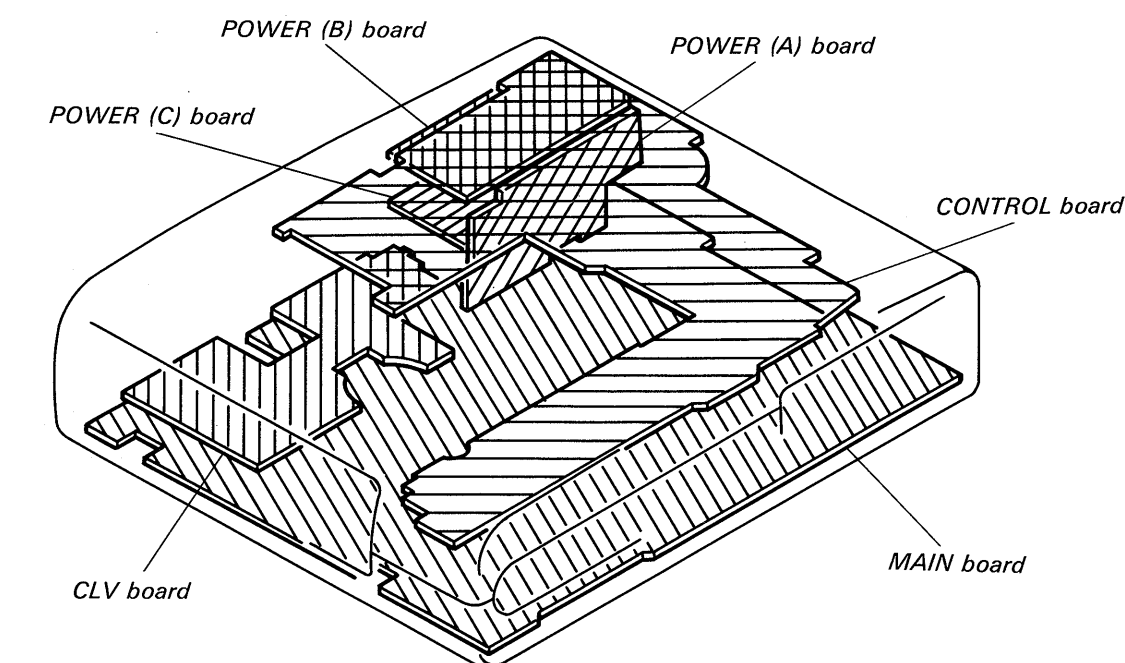

● Semiconductor Lead Layouts

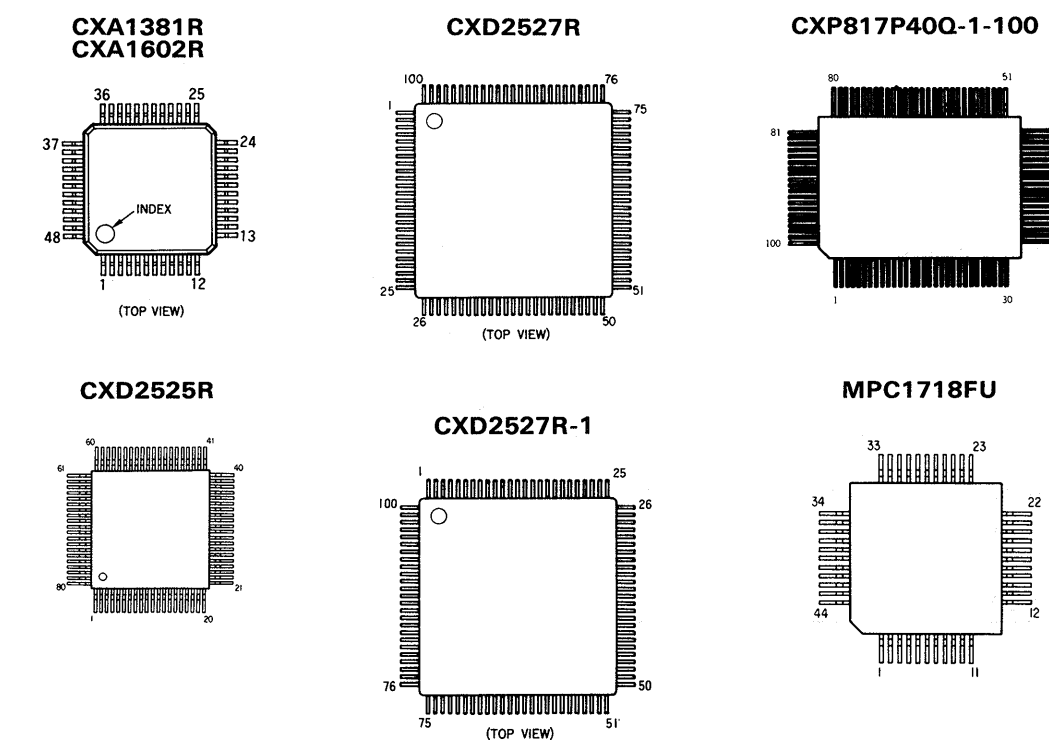

6-3. PRINTED WIRING BOARDS —CONTROL/POWER Section— • See page 36 for Circuit Boards Location and Semiconductor Lead Layouts.

● Semiconductor Location

Ref. No.	Location	Ref. No.	Location
D402	G-15	Q407	F-12
D404	E-11	Q408	E-12
D405	G-14	Q410	G-13
D407	E-16	Q411	G-14
D410	G-12	Q412	G-13
D411	E-12	Q413	G-13
D412	E-12	Q414	E-13
D413	E-11	Q415	E-13
D414	E-12	Q416	G-15
D415	I-15	Q417	E-11
D416	H-11	Q420	F-17
D417	G-12	Q421	I-13
D418	G-15	Q422	I-14
D419	H-16	Q423	H-12
D420	E-12	Q426	H-16
		Q428	G-16
IC401	G-16	Q429	G-11
IC402	I-15	Q430	G-16
IC701	C-9	Q431	I-12
		Q432	I-16
Q403	F-12	Q433	I-13
Q404	E-12	Q434	I-14
Q405	F-11	Q435	I-15
Q406	E-11	Q436	G-12

- For printed wiring boards.
- : Through hole.
- ▨ : Pattern from the side
- : Pattern of the rear side.

- Note:**
- All capacitors are in μF unless otherwise noted. pF: μF
 - 50WV or less are not indicated except for electrolytics and tantalums.
 - All resistors are in Ω and $\frac{1}{4}W$ or less unless otherwise specified.
 - % : indicates tolerance.
 - B+ Line
 - : adjustment for repair.
 - Power voltage is dc 10.5V and fed with regulated dc power supply from battery terminal.
 - Voltage is dc with respect to ground under no-signal (detuned) conditions.
 - no mark: PLAY
 - Signal path.
 - ▷ : PLAY (Analogue output) ▷▷ : PLAY (Digital output)

Caution:
 Pattern face side: Parts on the pattern face side seen from (Conductor Side) the pattern face are indicated.
 Parts face side: Parts on the parts face side seen from the (Component Side) parts face are indicated.

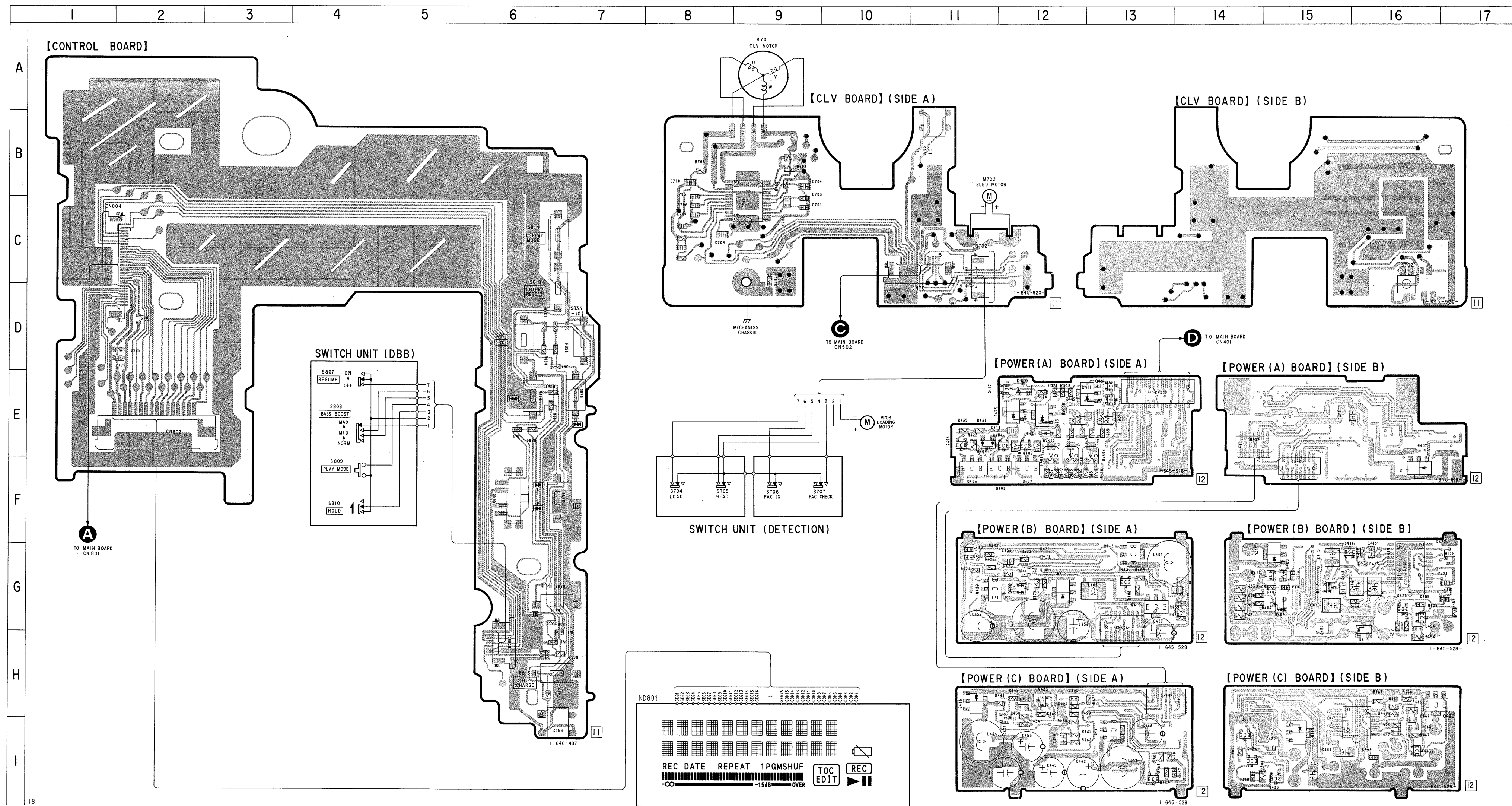

● Semiconductor Location

Ref. No.	Location	Ref. No.	Location
D301	A-14	IC604	H-14
D307	C-3	IC605	D-2
D309	H-9	IC606	E-14
D311	C-2	IC610	G-1
D401	H-10	IC611	F-14
D406	G-10	IC612	G-14
D420	I-11	IC613	F-1
D421	I-11	IC614	F-14
D422	I-10	IC615	G-2
D423	H-10	IC801	E-3
D424	G-3	IC802	E-4
D502	A-6	IC803	G-11
D503	E-4	IC806	H-11
D504	D-6	IC807	H-5
D505	E-5	IC808	F-4
D506	E-5		
D507	H-3	Q101	A-3
D514	B-5	Q102	B-3
D515	D-11	Q103	B-2
D803	G-11	Q105	B-2
D804	D-4	Q201	A-13
D806	F-3	Q202	B-12
D807	H-4	Q203	A-2
D808	H-4	Q205	A-2
D810	F-4	Q302	A-12
D811	F-3	C303	C-15
D812	E-4	C304	C-3
		C306	C-3
IC307	D-7	Q310	F-13
IC308	D-9	Q312	H-12
IC309	C-13	Q401	H-11
IC310	B-3	Q402	I-10
IC311	B-14	Q409	H-10
IC312	C-14	Q445	G-12
IC314	C-2	Q446	G-5
IC315	H-12	Q447	F-5
IC410	G-12	Q448	G-5
IC501	B-5	Q449	F-5
IC502	B-4	Q450	G-5
IC503	B-11	Q451	F-5
IC504	B-10	Q452	G-5
IC505	A-5	Q501	B-6
IC506	B-11	Q502	B-6
IC507	C-5	Q503	C-5
IC508	C-10	Q506	D-6
IC509	E-10	Q508	E-4
IC510	E-5	Q509	D-4
IC511	C-12	Q510	B-6
IC512	E-10	Q513	E-5
IC513	D-4	Q514	D-5
IC514	H-3	Q515	D-5
IC515	H-3	Q516	D-11
IC516	C-5	Q517	D-12
IC517	C-12	Q518	D-10
IC518	D-5	Q519	E-10
IC519	D-4	Q801	H-11
IC520	C-4	Q802	H-11
IC601	E-14	Q803	H-4
IC602	E-2	Q804	H-4
IC603	H-2	Q807	C-4



6-6. SCHEMATIC DIAGRAMS —MAIN Section-1—

• See page 61 for IC Block Diagrams.

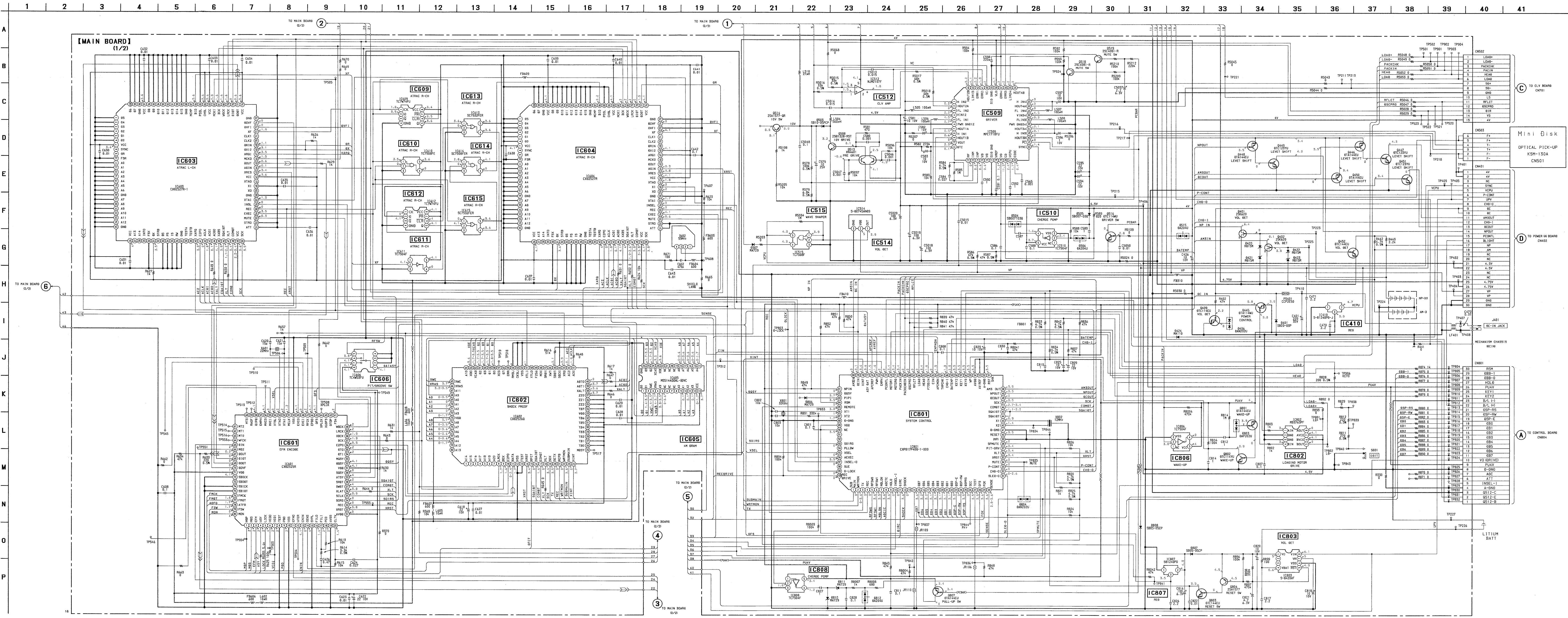

6-7. SCHEMATIC DIAGRAMS — MAIN Section-2—

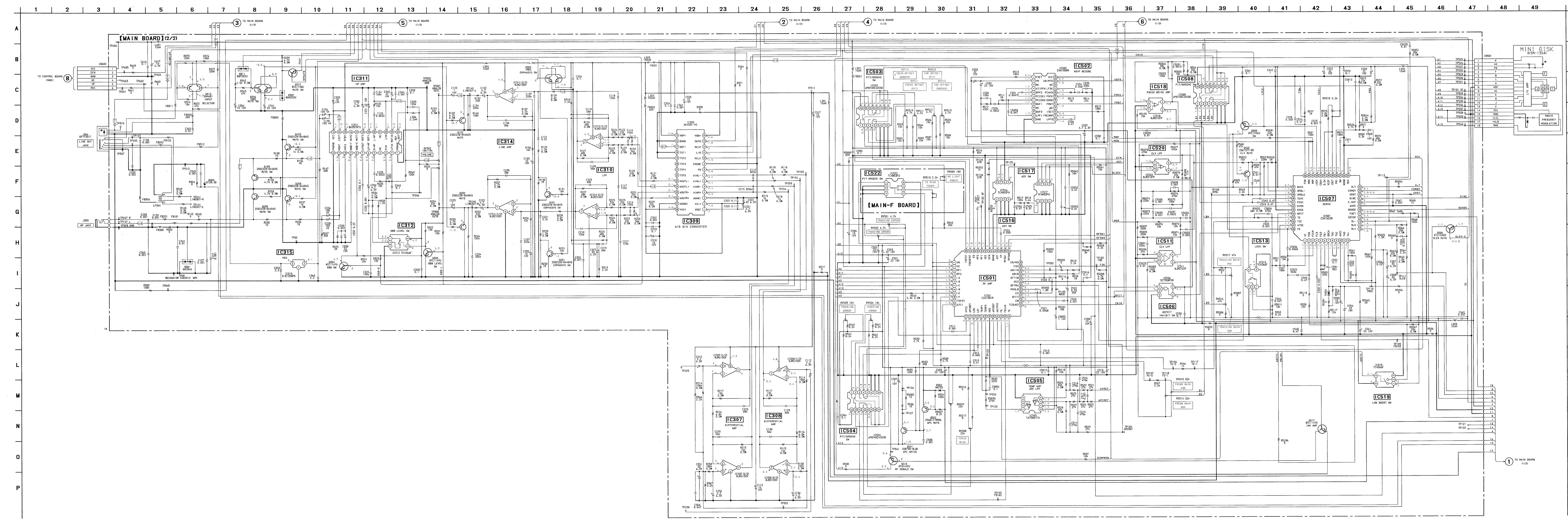

● IC Block Diagrams

IC501 CXA1381R

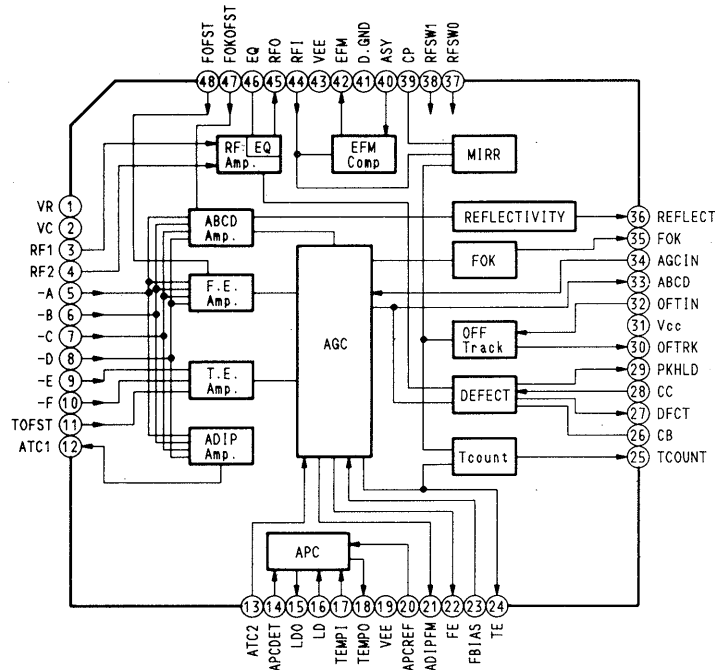

IC502 CXA1380M

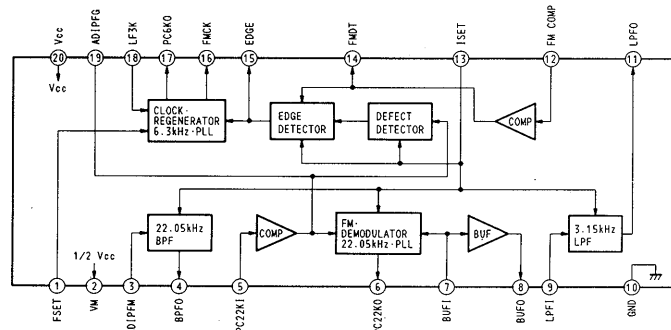

IC603, 604 CXD2527R

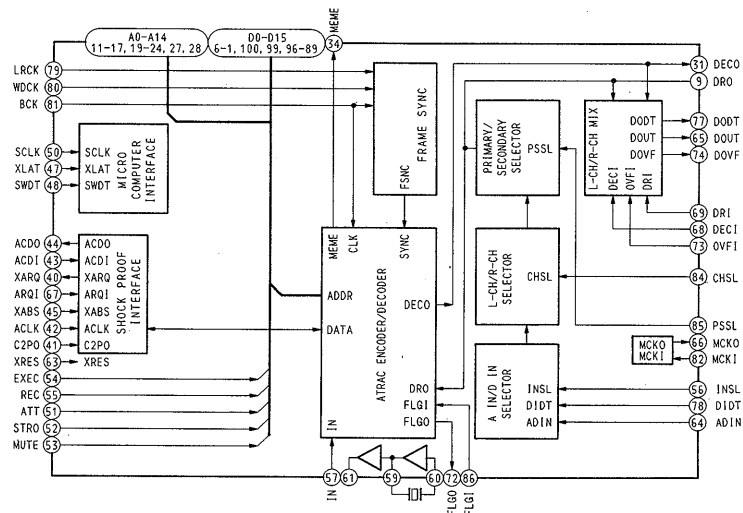

REVISED

**SECTION 7
EXPLODED VIEWS**

NOTE:

- -XX, -X mean standardized parts, so they may have some differences from the original one.
- Color Indication of Appearance Parts
Example:
KNOB, BALANCE (WHITE)... (RED)
 ↑ ↑
 Parts color Cabinet's color

- Items marked " * " are not stocked since they are seldom required for routine service. Some delay should be anticipated when ordering these items.
- The mechanical parts with no reference number in the exploded views are not supplied.
- Hardware (#mark) list is given in the last of this parts list.

The components identified by mark Δ or dotted line with mark Δ are critical for safety. Replace only with part number specified.

Les composants identifiés par une marque Δ sont critiques pour la sécurité. Ne les remplacer que par une pièce portant le numéro spécifié.

7-1. UPPER PANEL AND BOTTOM PANEL SECTION

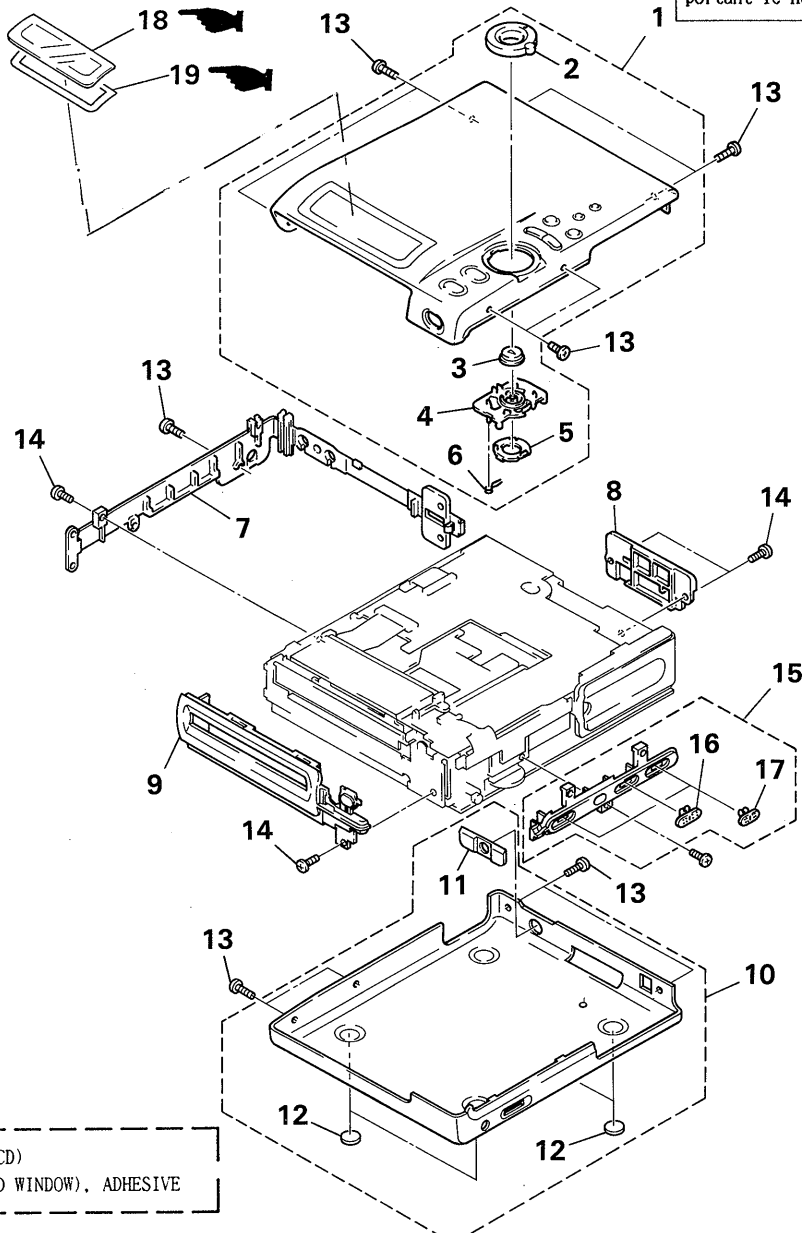

18 4-955-482-01 WINDOW (LCD)
19 4-955-483-02 SHEET (LCD WINDOW), ADHESIVE

Ref. No.	Part No.	Description	Remark	Ref. No.	Part No.	Description	Remark
1	X-4943-093-1	PANEL ASSY, UPPER		9	X-4943-096-1	PLATE (F) ASSY, ORNAMENTAL	
2	4-955-478-01	RING (A), SHUTTLE		10	X-4943-169-1	PANEL (PLAY) ASSY, BOTTOM	
3	4-955-480-01	BUTTON (PLAY)		11	4-955-466-01	PLATE (DC), ORNAMENTAL	
4	4-955-464-01	SHUTTLE (BASE)		12	4-912-641-01	FOOT, RUBBER	
5	4-955-479-02	RING (B), SHUTTLE		13	3-704-244-74	SCREW (P1. 7X4. 5)	
6	4-955-481-01	SPRING (SHUTTLE), TORSION		14	3-704-244-34	SCREW (P1. 7X2. 5)	
7	4-956-042-11	PLATE (R-PLAY), ORNAMENTAL		15	X-4943-098-1	PLATE (S) ASSY, ORNAMENTAL	
8	4-956-077-01	REINFORCEMENT (C)		16	4-955-502-01	KNOB (BASS BOOST)	
				17	4-955-503-01	KNOB (HOLD/RESUME)	

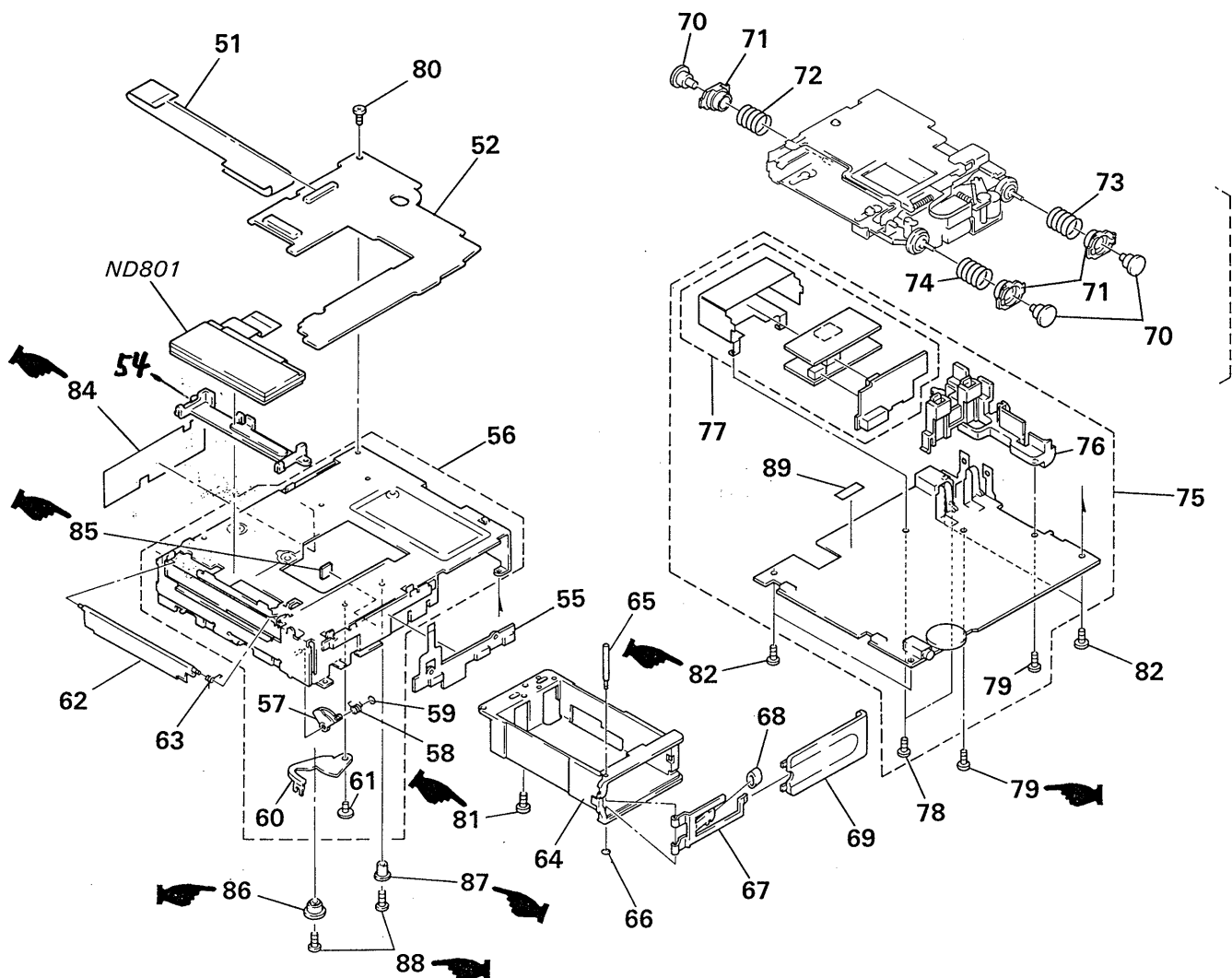
REVISED**7-2. CHASSIS SECTION**

Ref. No.	Part No.	Description	Remark
51	1-646-515-11	PC BOARD, RELAY (C) FLEXIBLE	
52	A-3264-096-A	CONTROL BOARD, COMPLETE	
53	3-318-203-61	SCREW, TAPPING P1.7X3	
54	4-955-532-01	HOLDER (LCD)	
55	1-466-924-11	SWITCH UNIT (DBB)	
56	X-4943-979-1	CHASSIS (P) ASSY, SUB	
57	4-955-526-02	LEVER (SHUTTER)	
58	4-955-528-01	SPRING (SHUTTER RD), TORSION	
59	3-348-953-11	WASHER	
60	4-955-542-01	LEVER (S OPEN)	
61	4-955-544-01	SCREW (M1.7)	
62	4-955-515-01	SHUTTER (EJECT)	
63	4-955-527-01	SPRING (SHUTTER E), TORSION	
64	4-955-529-01	CASE (BATTERY)	
65	4-955-530-01	SHAFT (BATTERY CASE LID)	
66	3-348-953-11	WASHER	
67	4-955-531-01	LEVER (BATTERY CASE LID)	

Ref. No.	Part No.	Description	Remark
* 68	3-537-790-41	REST, ARM, TENSION	
69	4-955-537-01	LID, BATTERY CASE	
70	4-955-511-01	DAMPER	
71	4-955-516-01	HOLDER (DAMPER)	
72	4-955-538-01	SPRING (MD1), COMPRESSION	
73	4-955-539-01	SPRING (MD2), COMPRESSION	
74	4-955-540-01	SPRING (MD3), COMPRESSION	
75	A-3275-781-A	MAIN BOARD, COMPLETE	
76	4-955-523-01	HOLDER (TERMINAL)	
77	A-3275-782-A	POWER BOARD, COMPLETE	
78	7-627-850-17	SCREW, PRECISION +P 1.4X2.5	
79	2-123-861-01	SCREW, TAPPING, P1.7X3	
80	4-955-841-01	SCREW	
81	3-704-244-34	SCREW (P1.7X2.5)	
82	2-134-636-41	SCREW (P1.7X4.0)	
83	A-9250-229-A	MD (PB) ASSY	
ND801	1-809-926-11	LCD MODULE	
* 84	4-957-572-01	SHEET (E-E), INSULATING	
* 85	9-911-839-XX	RETINER (B), MICROPHONE	
86	4-957-308-02	RING, REINFORCEMENT	
87	4-957-267-02	COLLAR, REINFORCEMENT	
88	3-704-244-84	SCREW (P1.7X5.0)	
* 89	4-957-258-01	SHEET, ADHESIVE	

REVISED

7-3. MECHANISM SECTION-1 (MT-MZ2P-106)

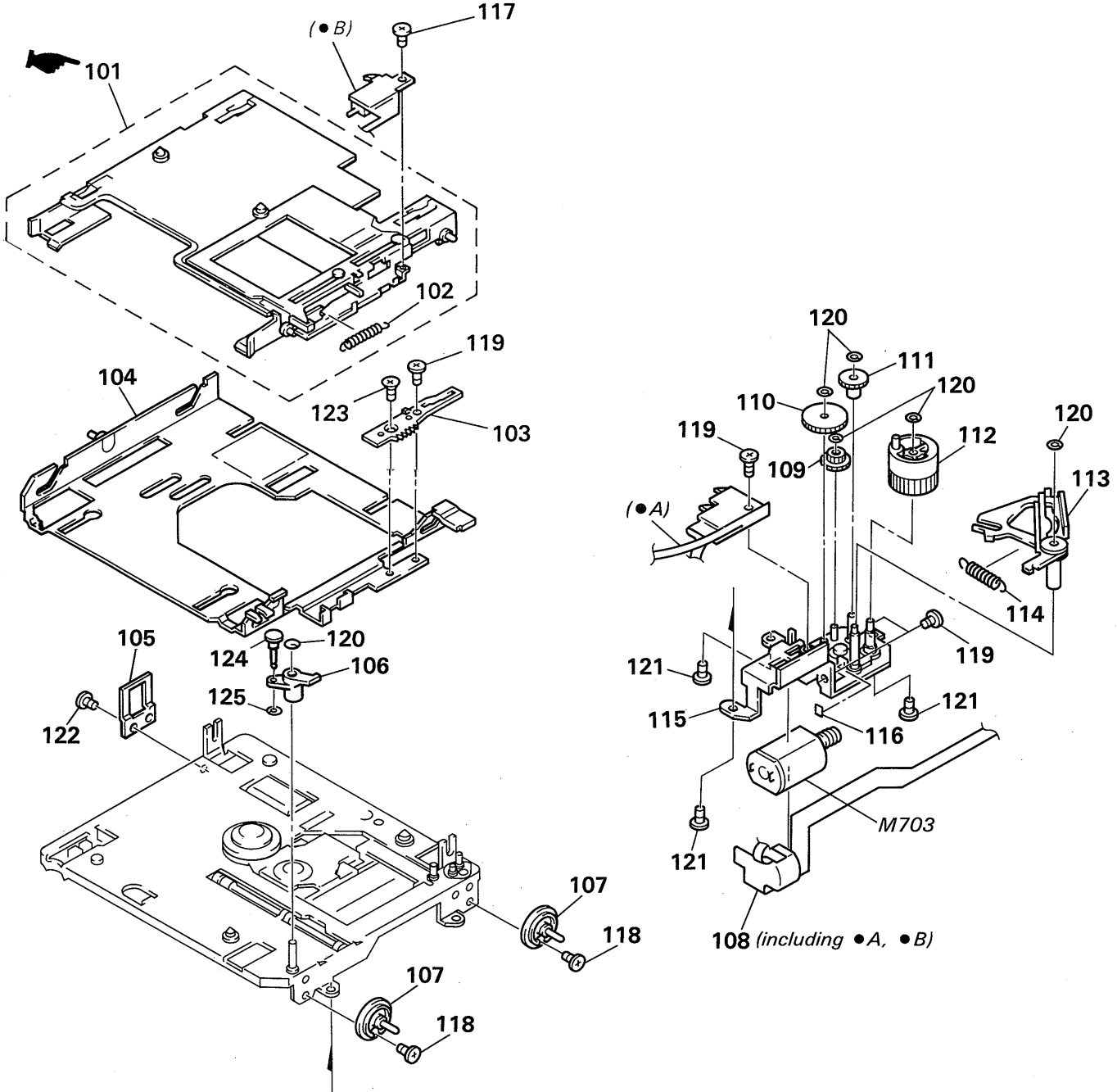

Ref. No.	Part No.	Description	Remark
101	X-4943-091-1	HOLDER ASSY	
102	3-385-103-01	SPRING, TENSION	
103	4-955-498-01	LEVER (RACK)	
104	X-4943-088-1	SLIDER ASSY, MAIN	
105	4-955-520-01	STOPPER, SHAFT	
106	4-955-500-01	LEVER (POSITIONING)	
107	X-4943-083-1	HOLDER (B) ASSY, VIBRATION PROOF	
108	1-466-925-11	SWITCH UNIT (DETECTION)	
109	4-955-496-01	GEAR (MIDWAY B)	
110	4-955-495-01	WHEEL, WORM	
111	4-955-497-01	GEAR (MIDWAY C)	
112	X-4943-085-1	GEAR (LOADING) ASSY	
113	X-4943-089-1	LEVER (LOADING) ASSY	

Ref. No.	Part No.	Description	Remark
114	3-385-104-01	SPRING, TENSION	
115	X-4943-084-1	CHASSIS ASSY, GEAR	
*116	3-317-577-01	SPACER (Z)	
117	3-363-220-21	SCREW (M1.4X1.8)	
118	4-955-841-21	SCREW	
119	3-704-197-02	SCREW (M1.4X1.6), LOCKING	
120	3-578-242-11	WASHER	
121	3-704-243-11	SCREW (P1.7X2.0)	
122	4-955-841-01	SCREW	
123	3-704-197-11	SCREW (M1.4X2.0), LOCKING	
124	3-386-541-02	SHAFT (D)	
125	3-320-540-01	WASHER	
M703	1-698-035-11	MOTOR, DC (LOADING)	

REVISED

7-4. MECHANISM SECTION-2 (MT-MZ2P-106)

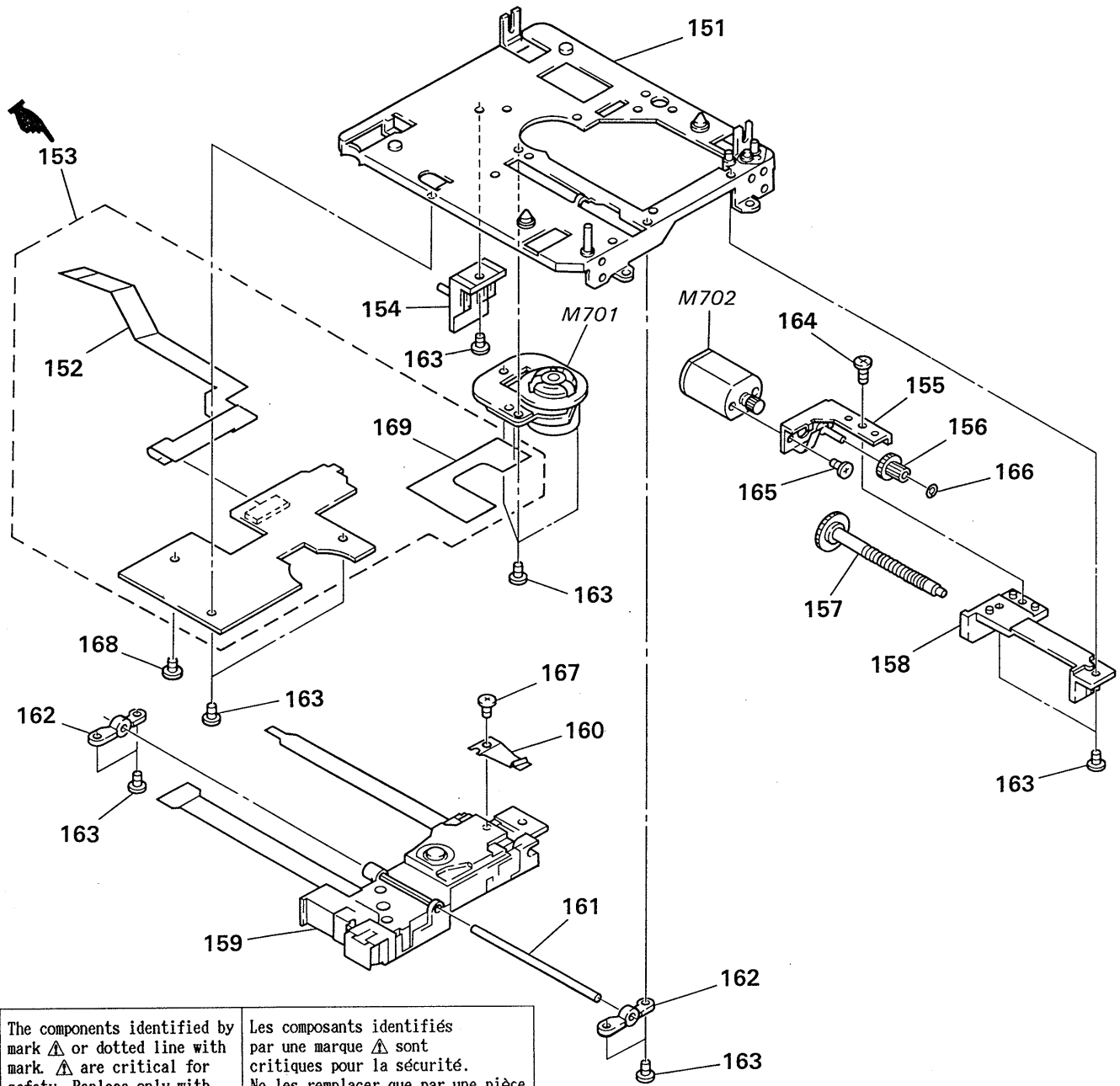

The components identified by mark Δ or dotted line with mark Δ are critical for safety. Replace only with part number specified.

Les composants identifiés par une marque Δ sont critiques pour la sécurité. Ne les remplacer que par une pièce portant le numéro spécifié.

Ref. No.	Part No.	Description	Remark	Ref. No.	Part No.	Description	Remark
	151	X-4943-080-1 CHASSIS ASSY		162	4-955-505-01	RETAINER, SHAFT, GUIDE	
	152	1-649-066-11 PC BOARD, RELAY FLXIBLE (B)		163	4-955-841-21	SCREW	
	153	A-3275-714-A CLV BOARD, COMPLETE		164	2-123-861-01	SCREW, TAPPING, P1. 7X3	
	154	X-4943-082-1 HOLDER (A) ASSY, VIBRATION PROOF		165	3-704-197-02	SCREW (M1. 4X1. 6), LOCKING	
	155	X-4943-087-1 HOLDER ASSY, MOTOR		166	3-325-394-11	WASHER, STOPPER	
	156	4-955-518-01 GEAR (B)		167	3-704-197-21	SCREW (M1. 4X2. 5), LOCKING	
	157	A-3263-172-A SCREW BLOCK ASSY, LEAD		168	2-134-636-21	SCREW (M1. 7X2. 5)	
	158	4-955-519-01 BRACKET (A)		169	1-645-921-11	CLV FLEXIBLE BOARD	
	Δ 159	8-853-001-21 DEVICE, MINI DISK KMS-130B(B)		M701	1-698-007-11	MOTOR (SPNDLE)	
	160	4-955-517-03 SPRING, FEED		M702	1-698-008-11	MOTOR, DC (SLED)	
	161	4-959-632-01 SHAFT (OP), GUIDE					

SECTION 8 ELECTRICAL PARTS LIST

CLV CLV FLEXIBLE CONTROL

NOTE:

- Due to standardization, replacements in the parts list may be different from the parts specified in the diagrams or the components used on the set.
- -XX and -X mean standardized parts, so they may have some difference from the original one.
- RESISTORS
All resistors are in ohms.
METAL: Metal-film resistor.
METAL OXIDE: Metal oxide-film resistor.
F: nonflammable

- Items marked "*" are not stocked since they are seldom required for routine service. Some delay should be anticipated when ordering these items.
- SEMICONDUCTORS
In each case, u: μ , for example:
uA ..: μ A. uPA..: μ PA.
uPB..: μ PB. uPC..: μ PC. uPD..: μ PD.
- CAPACITORS
uF: μ F
- COILS
uH: μ H

The components identified by mark Δ or dotted line with mark Δ are critical for safety. Replace only with part number specified.

Les composants identifiés par une marque Δ sont critiques pour la sécurité. Ne les remplacer que par une pièce portant le numéro spécifié.

When indicating parts by reference number, please include the board.

Ref. No.	Part No.	Description	Remark
	A-3275-714-A	CLV BOARD, COMPLETE *****	
	1-645-921-11	CLV FLEXIBLE BOARD *****	
		< CAPACITOR >	
C701	1-164-227-11	CERAMIC CHIP 0.022uF	10% 25V
C702	1-163-809-11	CERAMIC CHIP 0.047uF	10% 25V
C703	1-164-227-11	CERAMIC CHIP 0.022uF	10% 25V
C704	1-164-005-11	CERAMIC CHIP 0.47uF	25V
C705	1-162-964-81	CERAMIC CHIP 0.001uF	5% 50V
C706	1-162-964-81	CERAMIC CHIP 0.001uF	5% 50V
C707	1-162-964-81	CERAMIC CHIP 0.001uF	5% 50V
C708	1-162-967-11	CERAMIC CHIP 0.0033uF	10% 50V
C709	1-164-004-11	CERAMIC CHIP 0.1uF	10% 25V
C710	1-164-005-11	CERAMIC CHIP 0.47uF	25V
C711	1-164-360-11	CERAMIC CHIP 0.1uF	16V
		< CONNECTOR >	
CN701	1-573-355-11	CONNECTOR, FFC/FPC 15P	
CN702	1-573-347-11	CONNECTOR, FFC/FPC 7P	
		< IC >	
IC701	8-759-098-52	IC CXA-8027N-ELL2000	
		< RESISTOR >	
R701	1-218-716-11	METAL CHIP 10K 0.50%	1/16W
R702	1-218-716-11	METAL CHIP 10K 0.50%	1/16W
R703	1-216-815-11	METAL CHIP 330 5%	1/16W
R704	1-217-671-11	METAL CHIP 1 5%	1/10W
R705	1-217-671-11	METAL CHIP 1 5%	1/10W
R706	1-216-827-11	METAL CHIP 3.3K 5%	1/16W
R707	1-216-857-11	METAL CHIP 1M 5%	1/16W
		< SWITCH >	
S702	1-692-273-11	SWITCH, PUSH (1 KEY) (REFLECT)	
S703	1-572-467-31	SWITCH, PUSH (1 KEY) (LS)	

Ref. No.	Part No.	Description	Remark
	1-706-549-11	CONTROL BOARD *****	
		< CAPACITOR >	
C813	1-164-346-11	CERAMIC CHIP 1uF	16V
		< CONNECTOR >	
CN802	1-566-532-11	CONNECTOR, FPC (ZIF) 16P	
CN803	1-573-916-11	CONNECTOR, FFC/FPC (ZIF) 7P	
CN804	1-573-370-21	CONNECTOR, FFC/FPC 30P	
		< JUMPER RESISTOR >	
JW1	1-216-864-11	METAL CHIP 0 5%	1/16W
JW2	1-216-864-11	METAL CHIP 0 5%	1/16W
JW3	1-216-864-11	METAL CHIP 0 5%	1/16W
JW4	1-216-864-11	METAL CHIP 0 5%	1/16W
JW5	1-216-864-11	METAL CHIP 0 5%	1/16W
		< RESISTOR >	
R831	1-216-295-00	METAL CHIP 0 5%	1/10W
R853	1-216-830-11	METAL CHIP 5.6K 5%	1/16W
R854	1-218-675-11	METAL CHIP 200 0.50%	1/16W
R855	1-218-676-11	METAL CHIP 220 0.50%	1/16W
R856	1-216-814-11	METAL CHIP 270 5%	1/16W
R857	1-218-680-11	METAL CHIP 330 0.50%	1/16W
R858	1-218-482-11	METAL CHIP 430 0.50%	1/16W
R859	1-218-289-11	METAL CHIP 510 0.50%	1/16W
R860	1-220-373-11	METAL CHIP 620 0.50%	1/16W
R861	1-218-675-11	METAL CHIP 200 0.50%	1/16W
R880	1-216-820-11	METAL CHIP 820 5%	1/16W
R881	1-218-270-11	METAL CHIP 1.1K 0.50%	1/16W
		< SWITCH >	
S811	1-572-473-11	SWITCH, TACTIL (■)	
S812	1-692-088-11	SWITCH, TACTIL (△)	
S813	1-572-473-11	SWITCH, TACTIL (■ STOP/CHARGE)	
S814	1-572-473-11	SWITCH, TACTIL (DISPLAY MODE)	
S815	1-572-473-11	SWITCH, TACTIL (▶)	
S818	1-572-473-11	SWITCH, TACTIL (ENTER/REPEAT)	

CONTROL

MAIN

MAIN F

Ref. No.	Part No.	Description	Remark
S819	1-572-473-11	SWITCH, TACTIL (◀/◃)	
S820	1-572-473-11	SWITCH, TACTIL (▶/⋈)	
S833	1-572-473-11	SWITCH, TACTIL (+10)	
S834	1-572-473-11	SWITCH, TACTIL (-10)	
S835	1-572-467-31	SWITCH, PUSH (1 KEY) (◀▶)	

A-3275-781-A MAIN BOARD, COMPLETE			

1-647-401-11 MAIN F BOARD			

2-123-861-01 SCREW, TAPPING, P1. 7X3			
3-831-441-11 CUSHION (B)			
4-955-523-01 HOLDER (TERMINAL)			
4-955-524-01 CONTACT, PLUS			
4-955-525-01 CONTACT, MINUS			
4-955-534-01 TERMINAL BOARD			
4-956-974-01 SHEET (D-D), INSULATING			
4-957-126-01 CUSHION (PC BOARD)			
4-957-187-01 SPACER			
4-957-306-41 CUSHION			
7-627-850-17 SCREW, PRECISION +P 1.4X2.5			
< CAPACITOR >			
C112	1-135-237-11	TANTAL. CHIP 2.2uF	20% 6.3V
C113	1-135-263-21	TANTAL. CHIP 10uF	20% 10V
C115	1-164-473-11	CERAMIC CHIP 820PF	10% 50V
C116	1-162-927-11	CERAMIC CHIP 100PF	5% 50V
C117	1-162-928-11	CERAMIC CHIP 120PF	5% 50V
C118	1-162-928-11	CERAMIC CHIP 120PF	5% 50V
C119	1-162-925-11	CERAMIC CHIP 68PF	5% 50V
C120	1-162-925-11	CERAMIC CHIP 68PF	5% 50V
C121	1-137-294-11	FILM CHIP 0.01uF	5% 16V
C122	1-135-181-21	TANTALUM CHIP 4.7uF	20% 6.3V
C123	1-135-091-00	TANTALUM CHIP 1uF	20% 16V
C124	1-162-953-11	CERAMIC CHIP 100PF	5% 50V
C125	1-162-966-11	CERAMIC CHIP 0.0022uF	10% 50V
C126	1-135-335-11	TANTAL. CHIP 100uF	20% 4V
C127	1-162-964-11	CERAMIC CHIP 0.001uF	10% 50V
C128	1-135-335-11	TANTAL. CHIP 100uF	20% 4V
C129	1-162-925-11	CERAMIC CHIP 68PF	5% 50V
C130	1-162-924-11	CERAMIC CHIP 56PF	5% 50V
C133	1-162-953-11	CERAMIC CHIP 100PF	5% 50V
C134	1-162-959-11	CERAMIC CHIP 330PF	5% 50V
C135	1-135-263-21	TANTAL. CHIP 10uF	20% 10V
C136	1-135-237-11	TANTAL. CHIP 2.2uF	20% 6.3V
C137	1-162-957-11	CERAMIC CHIP 220PF	5% 50V
C138	1-162-922-11	CERAMIC CHIP 39PF	5% 50V

Ref. No.	Part No.	Description	Remark
C139	1-162-964-11	CERAMIC CHIP 0.001uF	10% 50V
C140	1-162-964-11	CERAMIC CHIP 0.001uF	10% 50V
C212	1-135-237-11	TANTAL. CHIP 2.2uF	20% 6.3V
C215	1-164-473-11	CERAMIC CHIP 820PF	10% 50V
C216	1-162-927-11	CERAMIC CHIP 100PF	5% 50V
C217	1-162-928-11	CERAMIC CHIP 120PF	5% 50V
C218	1-162-928-11	CERAMIC CHIP 120PF	5% 50V
C219	1-162-925-11	CERAMIC CHIP 68PF	5% 50V
C220	1-162-925-11	CERAMIC CHIP 68PF	5% 50V
C221	1-137-294-11	FILM CHIP 0.01uF	5% 16V
C222	1-135-181-21	TANTALUM CHIP 4.7uF	20% 6.3V
C223	1-135-091-00	TANTALUM CHIP 1uF	20% 16V
C224	1-162-953-11	CERAMIC CHIP 100PF	5% 50V
C225	1-162-966-11	CERAMIC CHIP 0.0022uF	10% 50V
C226	1-135-335-11	TANTAL. CHIP 100uF	20% 4V
C227	1-162-964-11	CERAMIC CHIP 0.001uF	10% 50V
C228	1-135-335-11	TANTAL. CHIP 100uF	20% 4V
C229	1-162-925-11	CERAMIC CHIP 68PF	5% 50V
C230	1-162-924-11	CERAMIC CHIP 56PF	5% 50V
C233	1-162-953-11	CERAMIC CHIP 100PF	5% 50V
C234	1-162-959-11	CERAMIC CHIP 330PF	5% 50V
C235	1-135-263-21	TANTAL. CHIP 10uF	20% 10V
C236	1-135-237-11	TANTAL. CHIP 2.2uF	20% 6.3V
C237	1-162-957-11	CERAMIC CHIP 220PF	5% 50V
C238	1-162-922-11	CERAMIC CHIP 39PF	5% 50V
C239	1-162-964-11	CERAMIC CHIP 0.001uF	10% 50V
C240	1-162-964-11	CERAMIC CHIP 0.001uF	10% 50V
C317	1-135-264-21	TANTAL. CHIP 22uF	20% 10V
C318	1-135-263-21	TANTAL. CHIP 10uF	20% 10V
C319	1-164-360-11	CERAMIC CHIP 0.1uF	16V
C320	1-164-360-11	CERAMIC CHIP 0.1uF	16V
C321	1-135-181-21	TANTALUM CHIP 4.7uF	20% 6.3V
C322	1-104-630-11	TANTAL. CHIP 33uF	20% 6.3V
C323	1-164-360-11	CERAMIC CHIP 0.1uF	16V
C324	1-164-360-11	CERAMIC CHIP 0.1uF	16V
C325	1-135-263-21	TANTAL. CHIP 10uF	20% 10V
C326	1-164-360-11	CERAMIC CHIP 0.1uF	16V
C327	1-104-630-11	TANTAL. CHIP 33uF	20% 6.3V
C328	1-164-360-11	CERAMIC CHIP 0.1uF	16V
C329	1-162-953-11	CERAMIC CHIP 100PF	5% 50V
C330	1-164-360-11	CERAMIC CHIP 0.1uF	16V
C331	1-135-264-21	TANTAL. CHIP 22uF	20% 10V
C332	1-135-181-21	TANTALUM CHIP 4.7uF	20% 6.3V
C333	1-135-263-21	TANTAL. CHIP 10uF	20% 10V
C334	1-135-181-21	TANTALUM CHIP 4.7uF	20% 6.3V
C335	1-162-964-11	CERAMIC CHIP 0.001uF	10% 50V
C336	1-164-360-11	CERAMIC CHIP 0.1uF	16V
C337	1-164-489-11	CERAMIC CHIP 0.22uF	10% 16V

MAIN

MAIN F

Ref. No.	Part No.	Description	Remark
C338	1-135-264-21	TANTAL. CHIP	22uF 20% 10V
C339	1-162-964-11	CERAMIC CHIP	0.001uF 10% 50V
C341	1-135-264-21	TANTAL. CHIP	22uF 20% 10V
C342	1-162-970-11	CERAMIC CHIP	0.01uF 10% 25V
C343	1-164-360-11	CERAMIC CHIP	0.1uF 16V
C344	1-162-964-11	CERAMIC CHIP	0.001uF 10% 50V
C345	1-135-240-21	TANTAL. CHIP	47uF 20% 10V
C349	1-162-964-11	CERAMIC CHIP	0.001uF 10% 50V
C350	1-164-361-11	CERAMIC CHIP	0.047uF 16V
C351	1-104-630-11	TANTAL. CHIP	33uF 20% 6.3V
C354	1-135-263-21	TANTAL. CHIP	10uF 20% 10V
C356	1-164-361-11	CERAMIC CHIP	0.047uF 16V
C359	1-164-505-11	CERAMIC CHIP	2.2uF 16V
C360	1-164-505-11	CERAMIC CHIP	2.2uF 16V
C361	1-162-964-11	CERAMIC CHIP	0.001uF 10% 50V
C362	1-162-964-11	CERAMIC CHIP	0.001uF 10% 50V
C363	1-162-970-11	CERAMIC CHIP	0.01uF 10% 25V
C365	1-162-964-11	CERAMIC CHIP	0.001uF 10% 50V
C401	1-126-949-75	ELECT	220uF 20% 35V
C426	1-135-263-21	TANTAL. CHIP	10uF 20% 10V
C470	1-164-505-11	CERAMIC CHIP	2.2uF 16V
C471	1-164-505-11	CERAMIC CHIP	2.2uF 16V
C472	1-162-970-11	CERAMIC CHIP	0.01uF 10% 25V
C501	1-135-264-21	TANTAL. CHIP	22uF 20% 10V
C502	1-135-264-21	TANTAL. CHIP	22uF 20% 10V
C503	1-135-264-21	TANTAL. CHIP	22uF 20% 10V
C504	1-164-360-11	CERAMIC CHIP	0.1uF 16V
C505	1-164-360-11	CERAMIC CHIP	0.1uF 16V
C506	1-135-232-11	TANTAL. CHIP	10uF 20% 16V
C507	1-135-091-00	TANTALUM CHIP	1uF 20% 16V
C508	1-162-964-11	CERAMIC CHIP	0.001uF 10% 50V
C509	1-135-264-21	TANTAL. CHIP	22uF 20% 10V
C510	1-162-970-11	CERAMIC CHIP	0.01uF 10% 25V
C511	1-162-964-11	CERAMIC CHIP	0.001uF 10% 50V
C512	1-164-490-11	CERAMIC CHIP	0.068uF 16V
C513	1-162-964-11	CERAMIC CHIP	0.001uF 10% 50V
C514	1-162-958-11	CERAMIC CHIP	270PF 5% 50V
C515	1-162-962-11	CERAMIC CHIP	470PF 10% 50V
C516	1-162-962-11	CERAMIC CHIP	470PF 10% 50V
C517	1-162-964-11	CERAMIC CHIP	0.001uF 10% 50V
C518	1-162-958-11	CERAMIC CHIP	270PF 5% 50V
C519	1-135-264-21	TANTAL. CHIP	22uF 20% 10V
C520	1-162-964-11	CERAMIC CHIP	0.001uF 10% 50V
C521	1-162-969-11	CERAMIC CHIP	0.0068uF 10% 25V
C522	1-135-073-00	TANTALUM CHIP	0.33uF 10% 35V
C523	1-164-360-11	CERAMIC CHIP	0.1uF 16V
C524	1-164-677-11	CERAMIC CHIP	0.033uF 10% 16V
C525	1-162-970-11	CERAMIC CHIP	0.01uF 10% 25V

Ref. No.	Part No.	Description	Remark
C526	1-164-005-11	CERAMIC CHIP	0.47uF 25V
C527	1-162-979-11	CERAMIC CHIP	0.0027uF 10% 50V
C529	1-162-966-11	CERAMIC CHIP	0.0022uF 10% 50V
C530	1-162-927-11	CERAMIC CHIP	100PF 5% 50V
C531	1-162-968-11	CERAMIC CHIP	0.0047uF 10% 50V
C532	1-135-264-21	TANTAL. CHIP	22uF 20% 10V
C533	1-135-264-21	TANTAL. CHIP	22uF 20% 10V
C534	1-164-490-11	CERAMIC CHIP	0.068uF 16V
C535	1-162-961-11	CERAMIC CHIP	330PF 10% 50V
C536	1-162-970-11	CERAMIC CHIP	0.01uF 10% 25V
C537	1-135-181-21	TANTALUM CHIP	4.7uF 20% 6.3V
C538	1-164-360-11	CERAMIC CHIP	0.1uF 16V
C539	1-164-360-11	CERAMIC CHIP	0.1uF 16V
C540	1-164-346-11	CERAMIC CHIP	1uF 16V
C541	1-162-970-11	CERAMIC CHIP	0.01uF 10% 25V
C542	1-164-346-11	CERAMIC CHIP	1uF 16V
C543	1-164-005-11	CERAMIC CHIP	0.47uF 25V
C544	1-164-005-11	CERAMIC CHIP	0.47uF 25V
C545	1-162-964-11	CERAMIC CHIP	0.001uF 10% 50V
C546	1-164-361-11	CERAMIC CHIP	0.047uF 16V
C547	1-162-953-11	CERAMIC CHIP	100PF 5% 50V
C548	1-164-005-11	CERAMIC CHIP	0.47uF 25V
C549	1-164-005-11	CERAMIC CHIP	0.47uF 25V
C550	1-164-677-11	CERAMIC CHIP	0.033uF 10% 16V
C551	1-162-952-11	CERAMIC CHIP	82PF 5% 50V
C552	1-164-360-11	CERAMIC CHIP	0.1uF 16V
C553	1-135-263-21	TANTAL. CHIP	10uF 20% 10V
C554	1-135-263-21	TANTAL. CHIP	10uF 20% 10V
C555	1-162-953-11	CERAMIC CHIP	100PF 5% 50V
C556	1-164-489-11	CERAMIC CHIP	0.22uF 10% 16V
C557	1-135-264-21	TANTAL. CHIP	22uF 20% 10V
C558	1-135-264-21	TANTAL. CHIP	22uF 20% 10V
C559	1-162-968-11	CERAMIC CHIP	0.0047uF 10% 50V
C561	1-135-264-21	TANTAL. CHIP	22uF 20% 10V
C563	1-164-361-11	CERAMIC CHIP	0.047uF 16V
C564	1-164-360-11	CERAMIC CHIP	0.1uF 16V
C565	1-162-964-11	CERAMIC CHIP	0.001uF 10% 50V
C567	1-164-361-11	CERAMIC CHIP	0.047uF 16V
C568	1-135-264-21	TANTAL. CHIP	22uF 20% 10V
C569	1-135-091-00	TANTALUM CHIP	1uF 20% 16V
C570	1-164-360-11	CERAMIC CHIP	0.1uF 16V
C571	1-164-346-11	CERAMIC CHIP	1uF 16V
C572	1-135-264-21	TANTAL. CHIP	22uF 20% 10V
C573	1-162-964-11	CERAMIC CHIP	0.001uF 10% 50V
C574	1-164-005-11	CERAMIC CHIP	0.47uF 25V
C578	1-164-677-11	CERAMIC CHIP	0.033uF 10% 16V
C579	1-135-224-11	TANTAL. CHIP	10uF 10% 25V
C580	1-162-964-11	CERAMIC CHIP	0.001uF 10% 50V
C581	1-135-263-21	TANTAL. CHIP	10uF 20% 10V

Ref. No.	Part No.	Description	Remark	Ref. No.	Part No.	Description	Remark
C582	1-135-208-11	TANTAL. CHIP	1uF 10% 10V	C808	1-164-360-11	CERAMIC CHIP	0.1uF 16V
C583	1-135-263-21	TANTAL. CHIP	10uF 20% 10V	C809	1-135-264-21	TANTAL. CHIP	22uF 20% 10V
C584	1-163-986-00	CERAMIC CHIP	0.027uF 10% 25V	C810	1-164-346-11	CERAMIC CHIP	1uF 16V
C586	1-164-360-11	CERAMIC CHIP	0.1uF 16V	C811	1-164-360-11	CERAMIC CHIP	0.1uF 16V
C587	1-164-346-11	CERAMIC CHIP	1uF 16V	C812	1-164-346-11	CERAMIC CHIP	1uF 16V
C588	1-164-360-11	CERAMIC CHIP	0.1uF 16V	C814	1-164-346-11	CERAMIC CHIP	1uF 16V
C589	1-164-346-11	CERAMIC CHIP	1uF 16V	C816	1-135-334-11	TANTAL. CHIP	100uF 20% 6.3V
C590	1-164-346-11	CERAMIC CHIP	1uF 16V	C817	1-164-505-11	CERAMIC CHIP	2.2uF 16V
C591	1-164-360-11	CERAMIC CHIP	0.1uF 16V	C818	1-135-263-21	TANTAL. CHIP	10uF 20% 10V
C592	1-164-346-11	CERAMIC CHIP	1uF 16V	C820	1-135-263-21	TANTAL. CHIP	10uF 20% 10V
C594	1-135-264-21	TANTAL. CHIP	22uF 20% 10V	C821	1-135-181-21	TANTALUM CHIP	4.7uF 20% 6.3V
C595	1-135-264-21	TANTAL. CHIP	22uF 20% 10V	C822	1-162-970-11	CERAMIC CHIP	0.01uF 10% 25V
C596	1-135-208-11	TANTAL. CHIP	1uF 10% 10V	C825	1-135-263-21	TANTAL. CHIP	10uF 20% 10V
C597	1-135-263-21	TANTAL. CHIP	10uF 20% 10V	C826	1-164-505-11	CERAMIC CHIP	2.2uF 16V
C598	1-162-960-11	CERAMIC CHIP	220PF 10% 50V	C827	1-164-346-11	CERAMIC CHIP	1uF 16V
C599	1-135-232-11	TANTAL. CHIP	10uF 20% 16V	C828	1-164-360-11	CERAMIC CHIP	0.1uF 16V
C608	1-164-360-11	CERAMIC CHIP	0.1uF 16V	C829	1-135-263-21	TANTAL. CHIP	10uF 20% 10V
C616	1-164-360-11	CERAMIC CHIP	0.1uF 16V	C830	1-164-346-11	CERAMIC CHIP	1uF 16V
C617	1-104-629-11	TANTAL. CHIP	15uF 20% 6.3V	C5001	1-162-961-11	CERAMIC CHIP	330PF 10% 50V
C618	1-135-264-21	TANTAL. CHIP	22uF 20% 10V	C5012	1-164-346-11	CERAMIC CHIP	1uF 16V
C620	1-162-917-11	CERAMIC CHIP	15PF 5% 50V	C5013	1-164-245-11	CERAMIC CHIP	0.015uF 10% 25V
C621	1-162-917-11	CERAMIC CHIP	15PF 5% 50V	C5014	1-164-245-11	CERAMIC CHIP	0.015uF 10% 25V
C622	1-135-264-21	TANTAL. CHIP	22uF 20% 10V	C5015	1-162-970-11	CERAMIC CHIP	0.01uF 10% 25V
C623	1-162-970-11	CERAMIC CHIP	0.01uF 10% 25V	C5016	1-164-360-11	CERAMIC CHIP	0.1uF 16V
C624	1-163-986-00	CERAMIC CHIP	0.027uF 10% 25V	C5017	1-164-360-11	CERAMIC CHIP	0.1uF 16V
C626	1-164-005-11	CERAMIC CHIP	0.47uF 25V	C5018	1-135-334-11	TANTAL. CHIP	100uF 20% 6.3V
C627	1-162-970-11	CERAMIC CHIP	0.01uF 10% 25V	C5019	1-135-334-11	TANTAL. CHIP	100uF 20% 6.3V
C628	1-162-970-11	CERAMIC CHIP	0.01uF 10% 25V	C5020	1-135-334-11	TANTAL. CHIP	100uF 20% 6.3V
C629	1-162-970-11	CERAMIC CHIP	0.01uF 10% 25V	C5022	1-164-363-11	CERAMIC CHIP	560PF 5% 50V
C630	1-162-970-11	CERAMIC CHIP	0.01uF 10% 25V	C5023	1-162-970-11	CERAMIC CHIP	0.01uF 10% 25V
C631	1-162-970-11	CERAMIC CHIP	0.01uF 10% 25V	C5025	1-162-970-11	CERAMIC CHIP	0.01uF 10% 25V
C632	1-162-970-11	CERAMIC CHIP	0.01uF 10% 25V	C5026	1-162-962-11	CERAMIC CHIP	470PF 10% 50V
C633	1-162-970-11	CERAMIC CHIP	0.01uF 10% 25V	C5031	1-162-965-11	CERAMIC CHIP	0.0015uF 10% 50V
C634	1-162-970-11	CERAMIC CHIP	0.01uF 10% 25V	C5032	1-162-953-11	CERAMIC CHIP	100PF 5% 50V
C635	1-162-970-11	CERAMIC CHIP	0.01uF 10% 25V	C5033	1-164-677-11	CERAMIC CHIP	0.033uF 10% 16V
C636	1-162-970-11	CERAMIC CHIP	0.01uF 10% 25V	C5034	1-162-970-11	CERAMIC CHIP	0.01uF 10% 25V
C637	1-162-970-11	CERAMIC CHIP	0.01uF 10% 25V	C5035	1-162-964-11	CERAMIC CHIP	0.001uF 10% 50V
C638	1-162-970-11	CERAMIC CHIP	0.01uF 10% 25V	C5036	1-162-964-11	CERAMIC CHIP	0.001uF 10% 50V
C639	1-162-970-11	CERAMIC CHIP	0.01uF 10% 25V	C5037	1-162-966-11	CERAMIC CHIP	0.0022uF 10% 50V
C640	1-162-970-11	CERAMIC CHIP	0.01uF 10% 25V	C5038	1-162-964-11	CERAMIC CHIP	0.001uF 10% 50V
C641	1-162-970-11	CERAMIC CHIP	0.01uF 10% 25V	C5039	1-162-970-11	CERAMIC CHIP	0.01uF 10% 25V
C642	1-164-360-11	CERAMIC CHIP	0.1uF 16V	C5046	1-162-964-11	CERAMIC CHIP	0.001uF 10% 50V
C643	1-162-970-11	CERAMIC CHIP	0.01uF 10% 25V	C5047	1-162-964-11	CERAMIC CHIP	0.001uF 10% 50V
C652	1-162-962-11	CERAMIC CHIP	470PF 10% 50V	C5048	1-164-004-11	CERAMIC CHIP	0.1uF 10% 25V
C801	1-164-360-11	CERAMIC CHIP	0.1uF 16V	C5050	1-162-970-11	CERAMIC CHIP	0.01uF 10% 25V
C802	1-162-915-11	CERAMIC CHIP	10PF 0.5PF 50V	C5052	1-162-970-11	CERAMIC CHIP	0.01uF 10% 25V
C803	1-162-915-11	CERAMIC CHIP	10PF 0.5PF 50V	C5053	1-162-970-11	CERAMIC CHIP	0.01uF 10% 25V
C807	1-164-360-11	CERAMIC CHIP	0.1uF 16V	C5054	1-164-360-11	CERAMIC CHIP	0.1uF 16V

Ref. No.	Part No.	Description	Remark
C5055	1-164-346-11	CERAMIC CHIP 1uF	16V
C5057	1-135-237-11	TANTAL. CHIP 2.2uF	20% 6.3V
C5059	1-163-809-11	CERAMIC CHIP 0.047uF	10% 25V
< CONNECTOR >			
CN401	1-573-315-21	CONNECTOR, BOARD TO BOARD 30P	
CN501	1-573-927-11	CONNECTOR, FFC/FPC (ZIF) 18P	
CN502	1-573-355-11	CONNECTOR, FFC/FPC 15P	
CN503	1-573-346-21	CONNECTOR, FFC/FPC 6P	
CN801	1-573-370-21	CONNECTOR, FFC/FPC 30P	
< DIODE >			
D301	8-719-941-23	DIODE DA204U	
D307	8-719-941-86	DIODE DAN202U	
D309	8-719-977-20	DIODE DTZ8.2B	
D311	8-719-941-09	DIODE DAP202U	
D401	8-719-974-51	DIODE SB20-03P	
D406	8-719-941-86	DIODE DAN202U	
D420	8-719-106-88	DIODE RD15M-B1	
D420	8-719-401-31	DIODE MA3047L-TX	
D421	8-719-106-88	DIODE RD15M-B1	
D422	8-719-106-88	DIODE RD15M-B1	
D423	8-719-106-88	DIODE RD15M-B1	
D424	8-719-404-46	DIODE MA110	
D502	8-719-420-51	DIODE MA729	
D503	8-719-938-78	DIODE SB10-05PCP	
D504	8-719-023-69	DIODE SB007T03Q	
D505	8-719-024-10	DIODE SB007-03Q	
D506	8-719-941-23	DIODE DA204U	
D507	8-719-420-51	DIODE MA729	
D515	8-719-941-23	DIODE DA204U	
D803	8-719-941-09	DIODE DAP202U	
D804	8-719-941-86	DIODE DAN202U	
D806	8-719-420-51	DIODE MA729	
D807	8-719-938-75	DIODE SB05-05CP	
D808	8-719-938-75	DIODE SB05-05CP	
D810	8-719-420-51	DIODE MA729	
D811	8-719-420-51	DIODE MA729	
D812	8-719-941-23	DIODE DA204U	
< FERRITE BEAD >			
FB101	1-543-949-11	BEAD, FERRITE (CHIP)	
FB102	1-543-949-11	BEAD, FERRITE (CHIP)	
FB201	1-543-949-11	BEAD, FERRITE (CHIP)	
FB202	1-543-949-11	BEAD, FERRITE (CHIP)	
FB301	1-543-949-11	BEAD, FERRITE (CHIP)	
FB302	1-543-949-11	BEAD, FERRITE (CHIP)	
FB303	1-543-949-11	BEAD, FERRITE (CHIP)	
FB305	1-543-949-11	BEAD, FERRITE (CHIP)	

Ref. No.	Part No.	Description	Remark
FB306	1-543-949-11	BEAD, FERRITE (CHIP)	
FB309	1-543-949-11	BEAD, FERRITE (CHIP)	
FB311	1-543-949-11	BEAD, FERRITE (CHIP)	
FB312	1-543-949-11	BEAD, FERRITE (CHIP)	
FB313	1-543-949-11	BEAD, FERRITE (CHIP)	
FB314	1-543-949-11	BEAD, FERRITE (CHIP)	
FB501	1-543-949-11	BEAD, FERRITE (CHIP)	
FB603	1-543-949-11	BEAD, FERRITE (CHIP)	
FB604	1-543-949-11	BEAD, FERRITE (CHIP)	
FB606	1-543-949-11	BEAD, FERRITE (CHIP)	
FB607	1-543-949-11	BEAD, FERRITE (CHIP)	
FB608	1-543-949-11	BEAD, FERRITE (CHIP)	
FB609	1-543-949-11	BEAD, FERRITE (CHIP)	
FB610	1-543-949-11	BEAD, FERRITE (CHIP)	
FB801	1-543-949-11	BEAD, FERRITE (CHIP)	
< IC >			
IC307	8-759-097-92	IC NJM2100V	
IC308	8-759-097-92	IC NJM2100V	
IC309	8-759-085-06	IC AK4501-VS	
IC310	8-759-097-92	IC NJM2100V	
IC311	8-759-510-56	IC BA3570FS	
IC312	8-759-234-77	IC TC4S66F	
IC314	8-759-097-92	IC NJM2100V	
IC315	8-759-161-52	IC S-81250PG-PD-T1	
IC410	8-759-161-50	IC S-81240PG-PJ-T1	
IC501	8-752-064-34	IC CXA1381R	
IC502	8-752-064-33	IC CXA1380N	
IC503	8-759-053-34	IC uPD74HC4053G	
IC504	8-759-053-34	IC uPD74HC4053G	
IC505	8-759-080-34	IC TA75W01FU	
IC506	8-759-035-26	IC SC7S08F	
IC507	8-752-055-94	IC CXA1602R	
IC508	8-759-053-34	IC uPD74HC4053G	
IC509	8-759-084-72	IC MPC1718FU	
IC510	8-759-031-84	IC SC7S04F	
IC511	8-759-710-79	IC NJM2107F	
IC512	8-759-710-79	IC NJM2107F	
IC513	8-759-234-77	IC TC4S66F	
IC514	8-759-087-73	IC S-80745AN-D9-T1	
IC515	8-759-234-20	IC TC7S08F	
IC516	8-759-082-61	IC TC4W53FU	
IC517	8-759-082-61	IC TC4W53FU	
IC518	8-759-710-79	IC NJM2107F	
IC519	8-759-234-77	IC TC4S66F	
IC520	8-759-710-79	IC NJM2107F	
IC522	8-759-082-61	IC TC4W53FU	
IC601	8-752-352-18	IC CXD2525R	
IC602	8-752-354-57	IC CXD2526Q	

Ref. No.	Part No.	Description	Remark
IC603	8-752-356-18	IC CXD2527R-1	
IC604	8-752-355-96	IC CXD2527R	
IC605	8-759-160-77	IC MS514400AL-80VC-SNY	
IC606	8-759-082-61	IC TC4W53FU-TE12R	
IC609	8-759-083-94	IC TC7W74FU-TE12R	
IC610	8-759-234-20	IC TC7S08F	
IC611	8-759-031-84	IC SC7S04F	
IC612	8-759-083-94	IC TC7W74FU-TE12R	
IC613	8-759-035-93	IC SC7S32FER	
IC614	8-759-035-26	IC SC7S08F	
IC615	8-759-035-93	IC SC7S32FER	
IC801	8-752-842-14	IC CXP817P40Q-1-000	
IC802	8-759-908-81	IC MB3763PF	
IC803	8-759-056-84	IC S-8420AF	
IC806	8-759-031-84	IC SC7S04F	
IC807	8-759-161-50	IC S-81240PG-PJ-T1	
IC808	8-759-031-84	IC SC7S04F	
< JACK >			
J303	1-569-809-11	JACK (SMALL TYPE) (◇)	
J304	8-749-923-96	IC GPIF351T (OPTICAL (DIGITAL)/LINE OUT)	
J401	1-580-428-11	JACK, DC (DC IN 10.5V)	
< COIL >			
L301	1-412-029-11	INDUCTOR CHIP 10uH	
L302	1-412-032-11	INDUCTOR CHIP 100uH	
L303	1-412-032-11	INDUCTOR CHIP 100uH	
L304	1-412-029-11	INDUCTOR CHIP 10uH	
L306	1-410-997-31	INDUCTOR CHIP 2.2uH	
L501	1-412-029-11	INDUCTOR CHIP 10uH	
L502	1-412-029-11	INDUCTOR CHIP 10uH	
L503	1-412-029-11	INDUCTOR CHIP 10uH	
L504	9-910-999-33	INDUCTOR 560UH	
L505	1-414-203-21	INDUCTOR 100uH	
L506	1-414-203-21	INDUCTOR 100uH	
L507	1-414-203-21	INDUCTOR 100uH	
L508	1-414-203-21	INDUCTOR 100uH	
L510	1-412-011-31	INDUCTOR CHIP 27uH	
L601	1-412-029-11	INDUCTOR CHIP 10uH	
L602	1-412-029-11	INDUCTOR CHIP 10uH	
L605	1-412-029-11	INDUCTOR CHIP 10uH	
L606	1-412-029-11	INDUCTOR CHIP 10uH	
< LINE FILTER >			
LF304	1-402-984-21	FILTER, COMMON MODE	
LF401	1-402-951-11	COIL, LINE FILTER	

Ref. No.	Part No.	Description	Remark
< IC LINK >			
PS401	1-533-282-21	RINK, IC	
< TRANSISTOR >			
Q101	8-729-144-16	TRANSISTOR 2SD2228-D44D45	
Q102	8-729-144-16	TRANSISTOR 2SD2228-D44D45	
Q103	8-729-144-16	TRANSISTOR 2SD2228-D44D45	
Q105	8-729-144-16	TRANSISTOR 2SD2228-D44D45	
Q201	8-729-144-16	TRANSISTOR 2SD2228-D44D45	
Q202	8-729-144-16	TRANSISTOR 2SD2228-D44D45	
Q203	8-729-144-16	TRANSISTOR 2SD2228-D44D45	
Q205	8-729-144-16	TRANSISTOR 2SD2228-D44D45	
Q302	8-729-907-39	TRANSISTOR IMD2	
Q303	8-729-906-33	TRANSISTOR DTC114YU	
Q304	8-729-906-33	TRANSISTOR DTC114YU	
Q306	8-729-907-39	TRANSISTOR IMD2	
Q310	8-729-402-84	TRANSISTOR XN4601	
Q312	8-729-924-31	TRANSISTOR DTA114WU-T106	
Q401	8-729-421-71	TRANSISTOR 2SK620	
Q402	8-729-421-71	TRANSISTOR 2SK620	
Q409	8-729-907-00	TRANSISTOR DTC114EU	
Q445	8-729-924-31	TRANSISTOR DTA114WU-T106	
Q446	8-729-905-12	TRANSISTOR DTA144EU	
Q447	8-729-924-65	TRANSISTOR DTC123YU	
Q448	8-729-905-12	TRANSISTOR DTA144EU	
Q449	8-729-924-65	TRANSISTOR DTC123YU	
Q450	8-729-905-12	TRANSISTOR DTA144EU	
Q451	8-729-924-65	TRANSISTOR DTC123YU	
Q452	8-729-905-18	TRANSISTOR DTC144EU	
Q501	8-729-101-07	TRANSISTOR 2SB798-DL	
Q502	8-729-216-22	TRANSISTOR 2SA1162	
Q503	8-729-922-10	TRANSISTOR 2SA1577-QR	
Q506	8-729-905-61	TRANSISTOR DTC124EU	
Q508	8-729-420-74	TRANSISTOR 2SD1328-RST	
Q509	8-729-905-61	TRANSISTOR DTC124EU	
Q510	8-729-905-12	TRANSISTOR DTA144EU	
Q513	8-729-402-84	TRANSISTOR XN4601	
Q514	8-729-922-10	TRANSISTOR 2SA1577-QR	
Q516	8-729-924-68	TRANSISTOR DTC114WU-T106	
Q517	8-729-906-33	TRANSISTOR DTC114YU	
Q518	8-729-120-28	TRANSISTOR 2SC1623-L5L6	
Q519	8-729-120-28	TRANSISTOR 2SC1623-L5L6	
Q801	8-729-905-12	TRANSISTOR DTA144EU	
Q802	8-729-906-33	TRANSISTOR DTC114YU	
Q803	8-729-905-18	TRANSISTOR DTC144EU	
Q804	8-729-922-10	TRANSISTOR 2SA1577-QR	
Q807	8-729-905-12	TRANSISTOR DTA144EU	

Ref. No.	Part No.	Description	Remark
< RESISTOR >			
R114	1-218-740-11	METAL CHIP	100K 0.50% 1/16W
R115	1-218-721-11	METAL CHIP	16K 0.50% 1/16W
R116	1-216-795-11	METAL CHIP	6.8K 0.50% 1/16W
R117	1-218-716-11	METAL CHIP	10K 0.50% 1/16W
R118	1-216-821-11	METAL CHIP	1K 5% 1/16W
R119	1-216-821-11	METAL CHIP	1K 5% 1/16W
R120	1-218-724-11	METAL CHIP	22K 0.50% 1/16W
R121	1-218-724-11	METAL CHIP	22K 0.50% 1/16W
R122	1-218-724-11	METAL CHIP	22K 0.50% 1/16W
R123	1-218-724-11	METAL CHIP	22K 0.50% 1/16W
R124	1-218-883-11	METAL CHIP	33K 0.50% 1/16W
R125	1-218-883-11	METAL CHIP	33K 0.50% 1/16W
R126	1-218-736-11	METAL CHIP	68K 0.50% 1/16W
R127	1-218-736-11	METAL CHIP	68K 0.50% 1/16W
R128	1-218-705-11	METAL CHIP	3.6K 0.50% 1/16W
R129	1-216-823-11	METAL CHIP	1.5K 5% 1/16W
R130	1-216-857-11	METAL CHIP	1M 5% 1/16W
R131	1-216-833-11	METAL CHIP	10K 5% 1/16W
R132	1-216-813-11	METAL CHIP	220 5% 1/16W
R133	1-216-829-11	METAL CHIP	4.7K 5% 1/16W
R134	1-218-724-11	METAL CHIP	22K 0.50% 1/16W
R135	1-216-833-11	METAL CHIP	10K 5% 1/16W
R136	1-216-800-11	METAL GLAZE	18 5% 1/16W
R137	1-216-821-11	METAL CHIP	1K 5% 1/16W
R138	1-216-799-11	METAL CHIP	15 5% 1/16W
R140	1-216-864-11	METAL CHIP	0 5% 1/16W
R146	1-216-845-11	METAL CHIP	100K 5% 1/16W
R147	1-216-815-11	METAL CHIP	330 5% 1/16W
R149	1-218-704-11	METAL CHIP	3.3K 0.50% 1/16W
R150	1-216-842-11	METAL CHIP	56K 5% 1/16W
R156	1-216-833-11	METAL CHIP	10K 5% 1/16W
R157	1-216-829-11	METAL CHIP	4.7K 5% 1/16W
R158	1-218-740-11	METAL CHIP	100K 0.50% 1/16W
R159	1-216-829-11	METAL CHIP	4.7K 5% 1/16W
R214	1-218-740-11	METAL CHIP	100K 0.50% 1/16W
R215	1-218-721-11	METAL CHIP	16K 0.50% 1/16W
R216	1-216-795-11	METAL CHIP	6.8K 0.50% 1/16W
R217	1-218-716-11	METAL CHIP	10K 0.50% 1/16W
R218	1-216-821-11	METAL CHIP	1K 5% 1/16W
R219	1-216-821-11	METAL CHIP	1K 5% 1/16W
R220	1-218-724-11	METAL CHIP	22K 0.50% 1/16W
R221	1-218-724-11	METAL CHIP	22K 0.50% 1/16W
R222	1-218-724-11	METAL CHIP	22K 0.50% 1/16W
R223	1-218-724-11	METAL CHIP	22K 0.50% 1/16W
R224	1-218-883-11	METAL CHIP	33K 0.50% 1/16W
R225	1-218-883-11	METAL CHIP	33K 0.50% 1/16W
R226	1-218-736-11	METAL CHIP	68K 0.50% 1/16W

Ref. No.	Part No.	Description	Remark
R227	1-218-736-11	METAL CHIP	68K 0.50% 1/16W
R228	1-218-705-11	METAL CHIP	3.6K 0.50% 1/16W
R229	1-216-823-11	METAL CHIP	1.5K 5% 1/16W
R230	1-216-857-11	METAL CHIP	1M 5% 1/16W
R231	1-216-833-11	METAL CHIP	10K 5% 1/16W
R232	1-216-813-11	METAL CHIP	220 5% 1/16W
R233	1-216-829-11	METAL CHIP	4.7K 5% 1/16W
R234	1-218-724-11	METAL CHIP	22K 0.50% 1/16W
R235	1-216-833-11	METAL CHIP	10K 5% 1/16W
R236	1-216-803-11	METAL CHIP	33 5% 1/16W
R237	1-216-821-11	METAL CHIP	1K 5% 1/16W
R238	1-216-446-11	METAL CHIP	1 5% 1/16W
R240	1-216-864-11	METAL CHIP	0 5% 1/16W
R246	1-216-845-11	METAL CHIP	100K 5% 1/16W
R247	1-216-815-11	METAL CHIP	330 5% 1/16W
R249	1-218-704-11	METAL CHIP	3.3K 0.50% 1/16W
R250	1-216-842-11	METAL CHIP	56K 5% 1/16W
R256	1-216-833-11	METAL CHIP	10K 5% 1/16W
R257	1-216-829-11	METAL CHIP	4.7K 5% 1/16W
R258	1-218-740-11	METAL CHIP	100K 0.50% 1/16W
R259	1-216-829-11	METAL CHIP	4.7K 5% 1/16W
R300	1-216-864-11	METAL CHIP	0 5% 1/16W
R317	1-216-864-11	METAL CHIP	0 5% 1/16W
R318	1-216-825-11	METAL CHIP	2.2K 5% 1/16W
R319	1-216-825-11	METAL CHIP	2.2K 5% 1/16W
R320	1-216-864-11	METAL CHIP	0 5% 1/16W
R321	1-216-833-11	METAL CHIP	10K 5% 1/16W
R322	1-216-833-11	METAL CHIP	10K 5% 1/16W
R323	1-216-833-11	METAL CHIP	10K 5% 1/16W
R324	1-216-833-11	METAL CHIP	10K 5% 1/16W
R325	1-216-857-11	METAL CHIP	1M 5% 1/16W
R326	1-216-864-11	METAL CHIP	0 5% 1/16W
R330	1-216-864-11	METAL CHIP	0 5% 1/16W
R333	1-216-822-11	METAL CHIP	1.2K 5% 1/16W
R334	1-216-829-11	METAL CHIP	4.7K 5% 1/16W
R337	1-216-864-11	METAL CHIP	0 5% 1/16W
R338	1-216-864-11	METAL CHIP	0 5% 1/16W
R339	1-216-829-11	METAL CHIP	4.7K 5% 1/16W
R340	1-216-845-11	METAL CHIP	100K 5% 1/16W
R341	1-216-845-11	METAL CHIP	100K 5% 1/16W
R342	1-216-823-11	METAL CHIP	1.5K 5% 1/16W
R343	1-216-841-11	METAL CHIP	47K 5% 1/16W
R354	1-216-793-11	METAL GLAZE	4.7 5% 1/16W
R366	1-216-825-11	METAL CHIP	2.2K 5% 1/16W
R367	1-216-825-11	METAL CHIP	2.2K 5% 1/16W
R369	1-216-833-11	METAL CHIP	10K 5% 1/16W
R370	1-216-830-11	METAL CHIP	5.6K 5% 1/16W
R371	1-216-830-11	METAL CHIP	5.6K 5% 1/16W

Ref. No.	Part No.	Description	Quantity	Unit	Remark
R372	1-216-841-11	METAL CHIP	47K	5%	1/16W
R373	1-216-845-11	METAL CHIP	100K	5%	1/16W
R374	1-216-833-11	METAL CHIP	10K	5%	1/16W
R375	1-216-851-11	METAL CHIP	330K	5%	1/16W
R376	1-216-845-11	METAL CHIP	100K	5%	1/16W
R383	1-216-845-11	METAL CHIP	100K	5%	1/16W
R384	1-216-864-11	METAL CHIP	0	5%	1/16W
R402	1-216-841-11	METAL CHIP	47K	5%	1/16W
R404	1-216-864-11	METAL CHIP	0	5%	1/16W
R441	1-216-864-11	METAL CHIP	0	5%	1/16W
R442	1-216-829-11	METAL CHIP	4.7K	5%	1/16W
R443	1-216-825-11	METAL CHIP	2.2K	5%	1/16W
R501	1-216-847-11	METAL CHIP	150K	5%	1/16W
R502	1-216-833-11	METAL CHIP	10K	5%	1/16W
R503	1-216-833-11	METAL CHIP	10K	5%	1/16W
R504	1-216-833-11	METAL CHIP	10K	5%	1/16W
R505	1-216-833-11	METAL CHIP	10K	5%	1/16W
R506	1-216-833-11	METAL CHIP	10K	5%	1/16W
R507	1-216-833-11	METAL CHIP	10K	5%	1/16W
R508	1-216-833-11	METAL CHIP	10K	5%	1/16W
R509	1-216-833-11	METAL CHIP	10K	5%	1/16W
R510	1-216-848-11	METAL CHIP	180K	5%	1/16W
R511	1-216-857-11	METAL CHIP	1M	5%	1/16W
R512	1-218-448-11	METAL GLAZE	430K	5%	1/16W
R513	1-216-857-11	METAL CHIP	1M	5%	1/16W
R514	1-216-838-11	METAL CHIP	27K	5%	1/16W
R515	1-216-848-11	METAL CHIP	180K	5%	1/16W
R516	1-216-844-11	METAL CHIP	82K	5%	1/16W
R517	1-216-845-11	METAL CHIP	100K	5%	1/16W
R518	1-216-830-11	METAL CHIP	5.6K	5%	1/16W
R519	1-216-825-11	METAL CHIP	2.2K	5%	1/16W
R520	1-216-857-11	METAL CHIP	1M	5%	1/16W
R521	1-216-838-11	METAL CHIP	27K	5%	1/16W
R522	1-216-838-11	METAL CHIP	27K	5%	1/16W
R523	1-216-838-11	METAL CHIP	27K	5%	1/16W
R524	1-216-838-11	METAL CHIP	27K	5%	1/16W
R525	1-216-838-11	METAL CHIP	27K	5%	1/16W
R526	1-216-844-11	METAL CHIP	82K	5%	1/16W
R527	1-216-838-11	METAL CHIP	27K	5%	1/16W
R528	1-216-844-11	METAL CHIP	82K	5%	1/16W
R529	1-216-838-11	METAL CHIP	27K	5%	1/16W
R530	1-216-849-11	METAL CHIP	220K	5%	1/16W
R533	1-216-815-11	METAL CHIP	330	5%	1/16W
R534	1-216-845-11	METAL CHIP	100K	5%	1/16W
R535	1-216-845-11	METAL CHIP	100K	5%	1/16W
R536	1-216-001-00	METAL CHIP	10	5%	1/10W
R538	1-216-826-11	METAL CHIP	2.7K	5%	1/16W
R539	1-216-826-11	METAL CHIP	2.7K	5%	1/16W
R540	1-216-827-11	METAL CHIP	3.3K	5%	1/16W

Ref. No.	Part No.	Description	Quantity	Unit	Remark
R541	1-216-832-11	METAL CHIP	8.2K	5%	1/16W
R542	1-216-832-11	METAL CHIP	8.2K	5%	1/16W
R543	1-216-832-11	METAL CHIP	8.2K	5%	1/16W
R544	1-216-832-11	METAL CHIP	8.2K	5%	1/16W
R545	1-218-287-11	METAL GLAZE	200	5%	1/16W
R546	1-216-821-11	METAL CHIP	1K	5%	1/16W
R547	1-216-825-11	METAL CHIP	2.2K	5%	1/16W
R548	1-216-841-11	METAL CHIP	47K	5%	1/16W
R549	1-216-825-11	METAL CHIP	2.2K	5%	1/16W
R550	1-216-841-11	METAL CHIP	47K	5%	1/16W
R551	1-216-857-11	METAL CHIP	1M	5%	1/16W
R552	1-216-864-11	METAL CHIP	0	5%	1/16W
R553	1-216-832-11	METAL CHIP	8.2K	5%	1/16W
R554	1-216-839-11	METAL CHIP	33K	5%	1/16W
R556	1-216-833-11	METAL CHIP	10K	5%	1/16W
R558	1-216-835-11	METAL CHIP	15K	5%	1/16W
R559	1-216-845-11	METAL CHIP	100K	5%	1/16W
R561	1-216-845-11	METAL CHIP	100K	5%	1/16W
R562	1-216-845-11	METAL CHIP	100K	5%	1/16W
R563	1-216-837-11	METAL CHIP	22K	5%	1/16W
R564	1-216-825-11	METAL CHIP	2.2K	5%	1/16W
R565	1-216-824-11	METAL CHIP	1.8K	5%	1/16W
R566	1-216-839-11	METAL CHIP	33K	5%	1/16W
R567	1-216-854-11	METAL CHIP	560K	5%	1/16W
R568	1-216-845-11	METAL CHIP	100K	5%	1/16W
R569	1-216-821-11	METAL CHIP	1K	5%	1/16W
R570	1-216-843-11	METAL CHIP	68K	5%	1/16W
R571	1-216-864-11	METAL CHIP	0	5%	1/16W
R572	1-216-837-11	METAL CHIP	22K	5%	1/16W
R573	1-216-837-11	METAL CHIP	22K	5%	1/16W
R574	1-216-848-11	METAL CHIP	180K	5%	1/16W
R575	1-216-827-11	METAL CHIP	3.3K	5%	1/16W
R577	1-216-857-11	METAL CHIP	1M	5%	1/16W
R578	1-216-846-11	METAL CHIP	120K	5%	1/16W
R579	1-216-832-11	METAL CHIP	8.2K	5%	1/16W
R581	1-216-817-11	METAL CHIP	470	5%	1/16W
R582	1-216-850-11	METAL CHIP	270K	5%	1/16W
R583	1-216-833-11	METAL CHIP	10K	5%	1/16W
R584	1-216-829-11	METAL CHIP	4.7K	5%	1/16W
R585	1-216-857-11	METAL CHIP	1M	5%	1/16W
R586	1-218-732-11	METAL CHIP	47K	0.50%	1/16W
R587	1-218-732-11	METAL CHIP	47K	0.50%	1/16W
R588	1-216-833-11	METAL CHIP	10K	5%	1/16W
R589	1-216-820-11	METAL CHIP	820	5%	1/16W
R592	1-216-845-11	METAL CHIP	100K	5%	1/16W
R593	1-216-845-11	METAL CHIP	100K	5%	1/16W
R594	1-216-845-11	METAL CHIP	100K	5%	1/16W
R595	1-216-841-11	METAL CHIP	47K	5%	1/16W
R596	1-216-864-11	METAL CHIP	0	5%	1/16W

MAIN

MAIN F

Ref. No.	Part No.	Description	Remark		
R597	1-216-833-11	METAL CHIP	10K	5%	1/16W
R598	1-216-864-11	METAL CHIP	0	5%	1/16W
R599	1-216-827-11	METAL CHIP	3.3K	5%	1/16W
R613	1-216-833-11	METAL CHIP	10K	5%	1/16W
R614	1-216-827-11	METAL CHIP	3.3K	5%	1/16W
R615	1-216-833-11	METAL CHIP	10K	5%	1/16W
R616	1-218-331-11	METAL GLAZE	51K	5%	1/16W
R617	1-216-821-11	METAL CHIP	1K	5%	1/16W
R623	1-216-833-11	METAL CHIP	10K	5%	1/16W
R624	1-216-833-11	METAL CHIP	10K	5%	1/16W
R625	1-216-845-11	METAL CHIP	100K	5%	1/16W
R626	1-216-821-11	METAL CHIP	1K	5%	1/16W
R627	1-216-821-11	METAL CHIP	1K	5%	1/16W
R629	1-216-830-11	METAL CHIP	5.6K	5%	1/16W
R630	1-216-821-11	METAL CHIP	1K	5%	1/16W
R631	1-216-821-11	METAL CHIP	1K	5%	1/16W
R633	1-216-813-11	METAL CHIP	220	5%	1/16W
R634	1-216-841-11	METAL CHIP	47K	5%	1/16W
R640	1-216-864-11	METAL CHIP	0	5%	1/16W
R641	1-216-864-11	METAL CHIP	0	5%	1/16W
R642	1-216-864-11	METAL CHIP	0	5%	1/16W
R643	1-216-864-11	METAL CHIP	0	5%	1/16W
R644	1-216-864-11	METAL CHIP	0	5%	1/16W
R645	1-216-864-11	METAL CHIP	0	5%	1/16W
R646	1-216-864-11	METAL CHIP	0	5%	1/16W
R647	1-216-864-11	METAL CHIP	0	5%	1/16W
R648	1-216-864-11	METAL CHIP	0	5%	1/16W
R649	1-216-864-11	METAL CHIP	0	5%	1/16W
R650	1-216-864-11	METAL CHIP	0	5%	1/16W
R651	1-216-864-11	METAL CHIP	0	5%	1/16W
R652	1-216-864-11	METAL CHIP	0	5%	1/16W
R653	1-216-864-11	METAL CHIP	0	5%	1/16W
R657	1-216-821-11	METAL CHIP	1K	5%	1/16W
R660	1-216-864-11	METAL CHIP	0	5%	1/16W
R662	1-216-864-11	METAL CHIP	0	5%	1/16W
R663	1-216-864-11	METAL CHIP	0	5%	1/16W
R669	1-216-864-11	METAL CHIP	0	5%	1/16W
R670	1-216-864-11	METAL CHIP	0	5%	1/16W
R671	1-216-809-11	METAL CHIP	100	5%	1/16W
R802	1-216-821-11	METAL CHIP	1K	5%	1/16W
R803	1-216-821-11	METAL CHIP	1K	5%	1/16W
R811	1-216-814-11	METAL CHIP	270	5%	1/16W
R812	1-218-676-11	METAL CHIP	220	0.50%	1/16W
R814	1-216-857-11	METAL CHIP	1M	5%	1/16W
R816	1-216-845-11	METAL CHIP	100K	5%	1/16W
R820	1-216-829-11	METAL CHIP	4.7K	5%	1/16W
R821	1-216-821-11	METAL CHIP	1K	5%	1/16W
R824	1-216-833-11	METAL CHIP	10K	5%	1/16W
R825	1-216-829-11	METAL CHIP	4.7K	5%	1/16W
R826	1-216-833-11	METAL CHIP	10K	5%	1/16W

Ref. No.	Part No.	Description	Remark		
R828	1-218-675-11	METAL CHIP	200	0.50%	1/16W
R829	1-216-864-11	METAL CHIP	0	5%	1/16W
R833	1-218-708-11	METAL CHIP	4.7K	0.50%	1/16W
R834	1-218-708-11	METAL CHIP	4.7K	0.50%	1/16W
R836	1-216-841-11	METAL CHIP	47K	5%	1/16W
R837	1-216-841-11	METAL CHIP	47K	5%	1/16W
R839	1-216-841-11	METAL CHIP	47K	5%	1/16W
R840	1-216-841-11	METAL CHIP	47K	5%	1/16W
R841	1-216-841-11	METAL CHIP	47K	5%	1/16W
R842	1-218-708-11	METAL CHIP	4.7K	0.50%	1/16W
R845	1-216-841-11	METAL CHIP	47K	5%	1/16W
R848	1-216-841-11	METAL CHIP	47K	5%	1/16W
R849	1-216-841-11	METAL CHIP	47K	5%	1/16W
R850	1-216-841-11	METAL CHIP	47K	5%	1/16W
R851	1-216-841-11	METAL CHIP	47K	5%	1/16W
R852	1-216-841-11	METAL CHIP	47K	5%	1/16W
R870	1-216-864-11	METAL CHIP	0	5%	1/16W
R871	1-216-864-11	METAL CHIP	0	5%	1/16W
R874	1-216-864-11	METAL CHIP	0	5%	1/16W
R875	1-216-864-11	METAL CHIP	0	5%	1/16W
R876	1-216-864-11	METAL CHIP	0	5%	1/16W
R877	1-216-864-11	METAL CHIP	0	5%	1/16W
R878	1-216-864-11	METAL CHIP	0	5%	1/16W
R879	1-216-864-11	METAL CHIP	0	5%	1/16W
R880	1-216-864-11	METAL CHIP	0	5%	1/16W
R881	1-216-864-11	METAL CHIP	0	5%	1/16W
R882	1-216-864-11	METAL CHIP	0	5%	1/16W
R883	1-216-864-11	METAL CHIP	0	5%	1/16W
R884	1-216-864-11	METAL CHIP	0	5%	1/16W
R885	1-216-864-11	METAL CHIP	0	5%	1/16W
R886	1-216-864-11	METAL CHIP	0	5%	1/16W
R887	1-216-864-11	METAL CHIP	0	5%	1/16W
R888	1-216-864-11	METAL CHIP	0	5%	1/16W
R889	1-216-864-11	METAL CHIP	0	5%	1/16W
R890	1-216-864-11	METAL CHIP	0	5%	1/16W
R891	1-216-851-11	METAL CHIP	330K	5%	1/16W
R892	1-216-864-11	METAL CHIP	0	5%	1/16W
R893	1-216-864-11	METAL CHIP	0	5%	1/16W
R894	1-216-845-11	METAL CHIP	100K	5%	1/16W
R896	1-216-845-11	METAL CHIP	100K	5%	1/16W
R897	1-216-853-11	METAL CHIP	470K	5%	1/16W
R898	1-216-851-11	METAL CHIP	330K	5%	1/16W
R899	1-216-809-11	METAL CHIP	100	5%	1/16W
R5000	1-216-820-11	METAL CHIP	820	5%	1/16W
R5001	1-216-864-11	METAL CHIP	0	5%	1/16W
R5002	1-216-850-11	METAL CHIP	270K	5%	1/16W
R5003	1-216-864-11	METAL CHIP	0	5%	1/16W
R5005	1-216-851-11	METAL CHIP	330K	5%	1/16W
R5006	1-216-838-11	METAL CHIP	27K	5%	1/16W
R5007	1-216-851-11	METAL CHIP	330K	5%	1/16W

Ref. No.	Part No.	Description	Remark
R5008	1-218-745-11	METAL CHIP	160K 0.50% 1/16W
R5011	1-216-833-11	METAL CHIP	10K 5% 1/16W
R5014	1-216-829-11	METAL CHIP	4.7K 5% 1/16W
R5015	1-216-839-11	METAL CHIP	33K 5% 1/16W
R5016	1-216-839-11	METAL CHIP	33K 5% 1/16W
R5017	1-216-843-11	METAL CHIP	68K 5% 1/16W
R5018	1-216-843-11	METAL CHIP	68K 5% 1/16W
R5020	1-216-857-11	METAL CHIP	1M 5% 1/16W
R5021	1-216-849-11	METAL CHIP	220K 5% 1/16W
R5022	1-216-835-11	METAL CHIP	15K 5% 1/16W
R5023	1-216-864-11	METAL CHIP	0 5% 1/16W
R5024	1-216-864-11	METAL CHIP	0 5% 1/16W
R5025	1-216-859-11	METAL GLAZE	1.5M 5% 1/16W
R5026	1-216-826-11	METAL CHIP	2.7K 5% 1/16W
R5027	1-216-832-11	METAL CHIP	8.2K 5% 1/16W
R5028	1-216-826-11	METAL CHIP	4.7K 5% 1/16W
R5029	1-216-864-11	METAL CHIP	0 5% 1/16W
R5030	1-216-864-11	METAL CHIP	0 5% 1/16W
R5031	1-216-839-11	METAL CHIP	33K 5% 1/16W
R5032	1-216-843-11	METAL CHIP	68K 5% 1/16W
R5033	1-216-864-11	METAL CHIP	0 5% 1/16W
R5034	1-216-857-11	METAL CHIP	1M 5% 1/16W
R5039	1-216-849-11	METAL CHIP	220K 5% 1/16W
R5043	1-216-864-11	METAL CHIP	0 5% 1/16W
R5044	1-216-864-11	METAL CHIP	0 5% 1/16W
R5045	1-216-864-11	METAL CHIP	0 5% 1/16W
R5046	1-216-864-11	METAL CHIP	0 5% 1/16W
R5047	1-216-864-11	METAL CHIP	0 5% 1/16W
R5048	1-216-864-11	METAL CHIP	0 5% 1/16W
R5049	1-216-864-11	METAL CHIP	0 5% 1/16W
R5050	1-216-864-11	METAL CHIP	0 5% 1/16W
R5051	1-216-864-11	METAL CHIP	0 5% 1/16W
R5052	1-216-864-11	METAL CHIP	0 5% 1/16W
R5053	1-216-864-11	METAL CHIP	0 5% 1/16W
R5054	1-216-864-11	METAL CHIP	0 5% 1/16W
R5055	1-216-830-11	METAL CHIP	5.6K 5% 1/16W
R5056	1-216-864-11	METAL CHIP	0 5% 1/16W
R5058	1-216-825-11	METAL CHIP	2.2K 5% 1/16W
R5059	1-216-845-11	METAL CHIP	100K 5% 1/16W
R5060	1-216-865-11	METAL CHIP	3K 5% 1/16W
R5061	1-216-833-11	METAL CHIP	10K 5% 1/16W
R5062	1-216-833-11	METAL CHIP	10K 5% 1/16W
R5063	1-216-857-11	METAL CHIP	1M 5% 1/16W
R5065	1-216-836-11	METAL CHIP	18K 5% 1/16W
R5066	1-216-839-11	METAL CHIP	33K 5% 1/16W
R5067	1-216-839-11	METAL CHIP	33K 5% 1/16W
R5068	1-216-864-11	METAL CHIP	0 5% 1/16W
R5069	1-216-864-11	METAL CHIP	0 5% 1/16W
R5070	1-216-833-11	METAL CHIP	10K 5% 1/16W

Ref. No.	Part No.	Description	Remark
R5071	1-216-833-11	METAL CHIP	10K 5% 1/16W
R5072	1-216-833-11	METAL CHIP	10K 5% 1/16W
R5073	1-216-849-11	METAL CHIP	220K 5% 1/16W
R5074	1-216-849-11	METAL CHIP	220K 5% 1/16W
R5075	1-216-845-11	METAL CHIP	100K 5% 1/16W
R5076	1-216-853-11	METAL CHIP	470K 5% 1/16W
R5077	1-216-853-11	METAL CHIP	470K 5% 1/16W
R5078	1-216-853-11	METAL CHIP	470K 5% 1/16W
R5079	1-216-837-11	METAL CHIP	22K 5% 1/16W
R5080	1-218-330-11	METAL GLAZE	11K 5% 1/16W
R5081	1-216-837-11	METAL CHIP	22K 5% 1/16W
R5082	1-216-001-00	METAL CHIP	10 5% 1/10W
R5086	1-216-864-11	METAL CHIP	0 5% 1/16W
R5087	1-216-864-11	METAL CHIP	0 5% 1/16W
R5093	1-216-860-11	METAL GLAZE	1.8M 5% 1/16W
R5096	1-216-833-11	METAL CHIP	10K 5% 1/16W
R5097	1-216-833-11	METAL CHIP	10K 5% 1/16W
R5099	1-216-864-11	METAL CHIP	0 5% 1/16W
R5105	1-216-835-11	METAL CHIP	15K 5% 1/16W
R5106	1-216-864-11	METAL CHIP	0 5% 1/16W
R5108	1-216-821-11	METAL CHIP	1K 5% 1/16W
R5109	1-216-864-11	METAL CHIP	0 5% 1/16W
R5110	1-216-835-11	METAL CHIP	15K 5% 1/16W
R5116	1-216-864-11	METAL CHIP	0 5% 1/16W
R5117	1-216-834-11	METAL CHIP	12K 5% 1/16W
R5118	1-216-864-11	METAL CHIP	0 5% 1/16W
R5200	1-216-864-11	METAL CHIP	0 5% 1/16W
R5201	1-216-809-11	METAL CHIP	100 5% 1/16W
R5202	1-216-821-11	METAL CHIP	1K 5% 1/16W
R5203	1-216-864-11	METAL CHIP	0 5% 1/16W
R5205	1-216-833-11	METAL CHIP	10K 5% 1/16W
R5206	1-216-295-00	METAL CHIP	0 5% 1/10W
R5207	1-216-295-00	METAL CHIP	0 5% 1/10W
R5208	1-216-829-11	METAL CHIP	4.7K 5% 1/16W
R5209	1-216-845-11	METAL CHIP	100K 5% 1/16W
R5210	1-216-845-11	METAL CHIP	100K 5% 1/16W
R5212	1-216-849-11	METAL CHIP	220K 5% 1/16W
R5216	1-216-864-11	METAL CHIP	0 5% 1/16W
R5217	1-216-864-11	METAL CHIP	0 5% 1/16W
R8004	1-216-841-11	METAL CHIP	47K 5% 1/16W
R8006	1-216-853-11	METAL CHIP	470K 5% 1/16W
R8007	1-216-821-11	METAL CHIP	1K 5% 1/16W
R8008	1-216-819-11	METAL CHIP	680 5% 1/16W
R8009	1-216-845-11	METAL CHIP	100K 5% 1/16W
R8041	1-216-841-11	METAL CHIP	47K 5% 1/16W
R8042	1-216-841-11	METAL CHIP	47K 5% 1/16W

MAIN

MAIN F

POWER

Ref. No.	Part No.	Description	Remark
< VARIABLE RESISTOR >			
RV302	1-223-172-21	RES, VAR, CARBON 10K/10K (VOLUME)	
RV501	1-238-089-11	RES, ADJ, CERMET 4.7K	
RV502	1-238-089-11	RES, ADJ, CERMET 4.7K	
RV503	1-238-090-11	RES, ADJ, CERMET 10K	
RV504	1-238-090-11	RES, ADJ, CERMET 10K	
RV505	1-223-270-21	RES, ADJ 100	
RV507	1-238-091-11	RES, ADJ, CERMET 22K	
RV508	1-238-091-11	RES, ADJ, CERMET 22K	
RV510	1-238-089-11	RES, ADJ, CERMET 4.7K	
RV511	1-238-089-11	RES, ADJ, CERMET 4.7K	
RV512	1-238-089-11	RES, ADJ, CERMET 4.7K	
RV513	1-238-089-11	RES, ADJ, CERMET 4.7K	
RV514	1-238-091-11	RES, ADJ, CERMET 22K	
RV515	1-238-091-11	RES, ADJ, CERMET 22K	
RV516	1-238-092-11	RES, ADJ, CERMET 47K	
RV517	1-238-092-11	RES, ADJ, CERMET 47K	
RV518	1-238-088-11	RES, ADJ, CERMET 2.2K	
RV519	1-238-088-11	RES, ADJ, CERMET 2.2K	
< SWITCH >			
S801	1-572-467-31	SWITCH, PUSH (1 KEY) (EDIT)	
< THERMISTOR >			
TH501	1-809-986-21	THERMISTOR NTH5G36B103K02TE	
< VIBRATOR >			
X601	1-579-725-21	VIBRATOR, CRYSTAL (22MHz)	
X602	1-579-847-21	OSCILLATOR, CRYSTAL (55MHz)	
X801	1-579-709-11	VIBRATOR, CRYSTAL (32KHz)	
X802	1-579-846-21	VIBRATOR, CERAMIC (12MHz)	

A-3275-782-A POWER BOARD, COMPLETE			

< CAPACITOR >			
C401	1-164-346-11	CERAMIC CHIP 1uF	16V
C405	1-162-959-11	CERAMIC CHIP 330PF	5% 50V
C406	1-162-964-11	CERAMIC CHIP 0.001uF	10% 50V
C407	1-126-924-11	ELECT 330uF	20% 10V
C408	1-164-346-11	CERAMIC CHIP 1uF	16V
C410	1-135-264-21	TANTAL. CHIP 22uF	20% 10V
C412	1-164-004-11	CERAMIC CHIP 0.1uF	10% 25V
C414	1-135-237-11	TANTAL. CHIP 2.2uF	20% 16V
C415	1-135-264-21	TANTAL. CHIP 22uF	20% 10V
C416	1-135-264-21	TANTAL. CHIP 22uF	20% 10V
C418	1-162-970-11	CERAMIC CHIP 0.01uF	10% 25V

Ref. No.	Part No.	Description	Remark
C421	1-164-315-11	CERAMIC CHIP 470PF	5% 50V
C431	1-162-970-11	CERAMIC CHIP 0.01uF	10% 25V
C432	1-162-970-11	CERAMIC CHIP 0.01uF	10% 25V
C433	1-127-561-11	ELECT (SOLID) 33uF	20% 10V
C434	1-135-149-21	TANTALUM CHIP 2.2uF	20% 10V
C435	1-162-964-11	CERAMIC CHIP 0.001uF	10% 50V
C436	1-164-004-11	CERAMIC CHIP 0.1uF	10% 25V
C437	1-162-961-11	CERAMIC CHIP 330PF	10% 50V
C438	1-164-004-11	CERAMIC CHIP 0.1uF	10% 25V
C439	1-162-961-11	CERAMIC CHIP 330PF	10% 50V
C440	1-162-964-11	CERAMIC CHIP 0.001uF	10% 50V
C442	1-104-725-81	ELECT (SOLID) 6.8uF	20% 25V
C443	1-135-149-21	TANTALUM CHIP 2.2uF	20% 10V
C444	1-162-970-11	CERAMIC CHIP 0.01uF	10% 25V
C445	1-127-561-11	ELECT (SOLID) 33uF	20% 10V
C446	1-127-561-11	ELECT (SOLID) 33uF	20% 10V
C447	1-162-964-11	CERAMIC CHIP 0.001uF	10% 50V
C450	1-104-726-81	ELECT (SOLID) 15uF	20% 16V
C452	1-104-726-81	ELECT (SOLID) 15uF	20% 16V
C453	1-164-004-11	CERAMIC CHIP 0.1uF	10% 25V
C454	1-162-964-11	CERAMIC CHIP 0.001uF	10% 50V
C455	1-162-961-11	CERAMIC CHIP 330PF	10% 50V
C456	1-127-561-11	ELECT (SOLID) 33uF	20% 10V
C457	1-162-961-11	CERAMIC CHIP 330PF	10% 50V
C458	1-163-986-00	CERAMIC CHIP 0.027uF	10% 25V
C459	1-126-505-91	CERAMIC CHIP 2.2uF	16V
C460	1-164-505-91	CERAMIC CHIP 2.2uF	16V
< CONNECTOR >			
CN402	1-573-343-21	CONNECTOR, BOARD TO BOARD 30P	
CN403	1-573-307-11	CONNECTOR, BOARD TO BOARD 14P	
CN404	1-573-335-11	CONNECTOR, BOARD TO BOARD 14P	
CN405	1-573-308-11	CONNECTOR, BOARD TO BOARD 16P	
CN406	1-573-336-11	CONNECTOR, BOARD TO BOARD 16P	
< DIODE >			
D402	8-719-106-16	DIODE RD6.8M-B1	
D404	8-719-991-65	DIODE SB02W03C	
D405	8-719-974-51	DIODE SB20-03P	
D407	8-719-974-51	DIODE SB20-03P	
D410	8-719-988-78	DIODE SB007W03Q	
D411	8-719-975-33	DIODE RB110C	
D412	8-719-975-33	DIODE RB110C	
D413	8-719-975-33	DIODE RB110C	
D414	8-719-404-46	DIODE MA110	
D415	8-719-975-33	DIODE RB110C	
D416	8-719-975-33	DIODE RB110C	
D417	8-719-975-33	DIODE RB110C	
D418	8-719-023-69	DIODE SB007T03Q	

POWER

Ref. No.	Part No.	Description	Remark
D419	8-719-106-16	DIODE RD6. 8M-B1	
D420	8-719-021-25	DIODE UZM4. 7X	
< IC >			
IC401	8-759-054-95	IC RF5C189	
IC402	8-759-990-43	IC TL1451ACDB-TL	
IC403	8-759-168-33	IC S-81245PG-P5-T1	
< COIL >			
L401	1-410-626-11	COIL, CHOKE 47uH	
L402	1-412-039-51	INDUCTOR CHIP 100uH	
L403	1-410-626-11	COIL, CHOKE 47uH	
L404	1-410-627-11	COIL, CHOKE 100uH	
L405	1-410-627-11	COIL, CHOKE 100uH	
< TRANSISTOR >			
Q403	8-729-923-45	TRANSISTOR 2SB1308-QR	
Q404	8-729-924-65	TRANSISTOR DTC123YU	
Q405	8-729-923-45	TRANSISTOR 2SB1308-QR	
Q406	8-729-924-65	TRANSISTOR DTC123YU	
Q407	8-729-923-45	TRANSISTOR 2SB1308-QR	
Q408	8-729-924-65	TRANSISTOR DTC123YU	
Q410	8-729-923-36	TRANSISTOR 2SD1963-Q. R	
Q411	8-729-120-28	TRANSISTOR 2SC1623-L5L6	
Q412	8-729-923-45	TRANSISTOR 2SB1308-QR	
Q413	8-729-120-28	TRANSISTOR 2SC1623-L5L6	
Q414	8-729-905-12	TRANSISTOR DTA144EU	
Q415	8-729-922-10	TRANSISTOR 2SA1577-QR	
Q416	8-729-905-15	TRANSISTOR DTC144WU	
Q420	8-729-905-12	TRANSISTOR DTA144EU	
Q421	8-729-923-45	TRANSISTOR 2SB1308-QR	
Q422	8-729-907-00	TRANSISTOR DTC114EU	
Q423	8-729-905-12	TRANSISTOR DTA144EU	
Q426	8-729-806-75	TRANSISTOR 2SB1120	
Q428	8-729-120-28	TRANSISTOR 2SC1623-L5L6	
Q429	8-729-806-75	TRANSISTOR 2SB1120	
Q430	8-729-120-28	TRANSISTOR 2SC1623-L5L6	
Q431	8-729-120-28	TRANSISTOR 2SC1623-L5L6	
Q432	8-729-120-28	TRANSISTOR 2SC1623-L5L6	
Q433	8-729-120-28	TRANSISTOR 2SC1623-L5L6	
Q434	8-729-120-28	TRANSISTOR 2SC1623-L5L6	
Q435	8-729-907-00	TRANSISTOR DTC114EU	
Q436	8-729-117-32	TRANSISTOR 2SC4177	
< RESISTOR >			
R401	1-216-033-00	METAL CHIP 220 5%	1/10W
R403	1-216-815-11	METAL CHIP 330 5%	1/16W
R405	1-216-821-11	METAL CHIP 1K 5%	1/16W
R406	1-216-823-11	METAL CHIP 1.5K 5%	1/16W

Ref. No.	Part No.	Description	Remark
R407	1-216-833-11	METAL CHIP 10K 5%	1/16W
R408	1-216-041-00	METAL CHIP 470 5%	1/10W
R409	1-217-671-11	METAL CHIP 1 5%	1/10W
R410	1-217-671-11	METAL CHIP 1 5%	1/10W
R411	1-216-817-11	METAL CHIP 470 5%	1/16W
R413	1-216-829-11	METAL CHIP 4.7K 5%	1/16W
R414	1-216-833-11	METAL CHIP 10K 5%	1/16W
R415	1-216-831-11	METAL CHIP 6.8K 5%	1/16W
R418	1-216-833-11	METAL CHIP 10K 5%	1/16W
R419	1-216-857-11	METAL CHIP 1M 5%	1/16W
R421	1-216-033-00	METAL CHIP 220 5%	1/10W
R422	1-216-037-00	METAL CHIP 330 5%	1/10W
R424	1-216-836-11	METAL CHIP 18K 5%	1/16W
R425	1-216-833-11	METAL CHIP 10K 5%	1/16W
R426	1-216-825-11	METAL CHIP 2.2K 5%	1/16W
R427	1-216-845-11	METAL CHIP 100K 5%	1/16W
R428	1-216-821-11	METAL CHIP 1K 5%	1/16W
R429	1-216-833-11	METAL CHIP 10K 5%	1/16W
R430	1-216-833-11	METAL CHIP 10K 5%	1/16W
R431	1-217-671-11	METAL CHIP 1 5%	1/10W
R432	1-216-857-11	METAL CHIP 1M 5%	1/16W
R433	1-217-671-11	METAL CHIP 1 5%	1/10W
R434	1-216-833-11	METAL CHIP 10K 5%	1/16W
R435	1-216-835-11	METAL CHIP 15K 5%	1/16W
R436	1-216-833-11	METAL CHIP 10K 5%	1/16W
R437	1-216-833-11	METAL CHIP 10K 5%	1/16W
R438	1-216-821-11	METAL CHIP 1K 5%	1/16W
R439	1-216-821-11	METAL CHIP 1K 5%	1/16W
R440	1-216-833-11	METAL CHIP 10K 5%	1/16W
R442	1-216-841-11	METAL CHIP 47K 5%	1/16W
R443	1-216-825-11	METAL CHIP 2.2K 5%	1/16W
R445	1-216-815-11	METAL CHIP 330 5%	1/16W
R446	1-216-031-00	METAL CHIP 180 5%	1/10W
R447	1-216-833-11	METAL CHIP 10K 5%	1/16W
R448	1-216-821-11	METAL CHIP 1K 5%	1/16W
R449	1-216-821-11	METAL CHIP 1K 5%	1/16W
R450	1-216-828-11	METAL CHIP 3.9K 5%	1/16W
R451	1-216-825-11	METAL CHIP 2.2K 5%	1/16W
R452	1-216-833-11	METAL CHIP 10K 5%	1/16W
R453	1-216-857-11	METAL CHIP 1M 5%	1/16W
R454	1-216-033-00	METAL CHIP 220 5%	1/10W
R455	1-216-833-11	METAL CHIP 10K 5%	1/16W
R456	1-216-821-11	METAL CHIP 1K 5%	1/16W
R457	1-216-823-11	METAL CHIP 1.5K 5%	1/16W
R458	1-216-833-11	METAL CHIP 10K 5%	1/16W
R459	1-216-833-11	METAL CHIP 10K 5%	1/16W
R460	1-216-821-11	METAL CHIP 1K 5%	1/16W
R461	1-216-829-11	METAL CHIP 4.7K 5%	1/16W

POWER

Ref. No.	Part No.	Description	Remark		
R462	1-216-833-11	METAL CHIP	10K	5%	1/16W
R463	1-216-829-11	METAL CHIP	4.7K	5%	1/16W
R464	1-216-833-11	METAL CHIP	10K	5%	1/16W
R465	1-216-833-11	METAL CHIP	10K	5%	1/16W
R466	1-216-825-11	METAL CHIP	2.2K	5%	1/16W
R467	1-216-031-00	METAL CHIP	180	5%	1/10W
R468	1-216-836-11	METAL CHIP	18K	5%	1/16W
R469	1-216-857-11	METAL CHIP	1M	5%	1/16W
R470	1-216-821-11	METAL CHIP	1K	5%	1/16W
R471	1-216-821-11	METAL CHIP	1K	5%	1/16W
R472	1-216-864-11	METAL CHIP	0	5%	1/16W
R473	1-216-833-11	METAL CHIP	10K	5%	1/16W
R474	1-216-864-11	METAL CHIP	0	5%	1/16W
R476	1-216-811-11	METAL CHIP	150	5%	1/16W
R477	1-216-833-11	METAL CHIP	10K	5%	1/16W
R478	1-216-841-11	METAL CHIP	47K	5%	1/16W
R479	1-216-841-11	METAL CHIP	47K	5%	1/16W

< VARIABLE RESISTOR >

RV401	1-238-089-11	RES, ADJ, CERMET	4.7K
RV402	1-238-088-11	RES, ADJ, CERMET	2.2K
RV403	1-238-089-11	RES, ADJ, CERMET	4.7K
RV405	1-238-090-11	RES, ADJ, CERMET	10K
RV406	1-238-090-11	RES, ADJ, CERMET	10K

MISCELLANEOUS

51	1-646-515-11	PC BOARD, RELAY (C) FLEXIBLE
55	1-466-924-11	SWITCH UNIT (DBB)
108	1-466-925-11	SWITCH UNIT (DETECTION)
152	1-645-922-11	PC BOARD, RELAY (B) FLEXIBLE
△159	8-848-269-01	DEVICE, MINIATURE DISK KMS-130A
M701	1-698-007-11	MOTOR (SPNDLE)
M702	1-698-008-11	MOTOR, DC (SLED)
M703	1-698-035-11	MOTOR, DC (LOADING)
ND801	1-809-926-11	LCD MODULE

ACCESSORIES & PACKING MATERIALS

1-466-884-11	ADAPTOR, AC (AC-MZ1) (US, Canadian)
1-466-885-11	ADAPTOR, AC (AC-MZ1) (AEP)
1-466-886-11	ADAPTOR, AC (AC-MZ1) (UK)
1-555-658-21	CORD, CONNECTION
3-756-162-11	MANUAL, INSTRUCTION (ENGLISH, FRENCH, GERMAN, SPANISH) (Canadian, AEP)
3-756-162-21	MANUAL, INSTRUCTION (ENGLISH) (US, UK)

Ref. No.	Part No.	Description	Remark
	3-756-162-41	MANUAL, INSTRUCTION (DUTCH, SWEDISH, ITALIAN, PORTUGUESE) (AEP)	
	4-956-078-01	CASE (PLAY), CARRYING	
*	4-956-253-01	CUSHION, MAIN	
*	4-956-254-01	CUSHION (UPPER)	
*	4-956-255-01	CUSHION (LOWER)	
*	4-956-260-02	INDIVIDUAL CARTON	
	8-953-521-90	HEADPHONE MDR-34D SET (US)	
	8-953-536-90	HEADPHONE MDR-E743 SET (Canadian, AEP, UK)	

The components identified by mark △ or dotted line with mark △ are critical for safety. Replace only with part number specified.	Les composants identifiés par une marque △ sont critiques pour la sécurité. Ne les remplacer que par une pièce portant le numéro spécifié.
--	--

9-957-536-11
Including 9-957-536-87
9-957-536-89
9-957-536-91
With 9-957-536-86

Sony Corporation
General Audio Group

English
92L1894-1
Printed in Japan
©1992:12
Published by Audio Corporate Planning Group

MZ-2P

SONY[®] SERVICE MANUAL

*US Model
Canadian Model
AEP Model
UK Model*

SUPPLEMENT-1

File this supplement with the service manual.

Subject:

1. The MAIN board of last digit "-13"
2. The CONTROL board of last digit "-12"
3. Adjustment location of MAIN board.
4. Block diagram
5. Electrical parts list of MAIN and CONTROL boards

Note.

- * The schematic diagram of this MAIN board is almost the same as MZ-1 except things below. Refer the MZ-1 supplement-1.
 - The circuit enclosed with broken line is not necessary for MZ-2P.
 - Further, there are difference as shown in the following table.
 - AE5 means German and Swiss models.

MODEL NAME	DESTINATION	R662 R663 R5016 R8043	R8042	Q517	R538 R539	R5039	R5222	C474	C475	R102 R202 R303	FB315 FB316	FB317 FB318	R317	LEAD WIRE
MZ-1	EXCEPT AE5	NOT USED	NOT USED	NOT USED	2.2kΩ	270KΩ	NOT USED	NOT USED	NOT USED	0Ω	600Ω	600Ω	0Ω	A
	AE5	NOT USED	NOT USED	NOT USED	2.2kΩ	270KΩ	NOT USED	1000pF	0.01μF	FB104 FB204 FB308 600Ω	R359 F360 0Ω	R361 R362 0Ω	NOT USED	B
MZ-2P	EXCEPT AE5	NOT USED	NOT USED	NOT USED	2.2kΩ	NOT USED	NOT USED	NOT USED	NOT USED	NOT USED	600Ω	NOT USED	0Ω	NOT USED
	AE5	0Ω	47kΩ	DTC 114YU	2.7kΩ	NOT USED	270kΩ	1000pF	0.01μF	NOT USED	R359 R360 0Ω	NOT USED	0Ω	NOT USED

Adjustment Location :

[MAIN BOARD] (SIDE-B) (last digit -13)

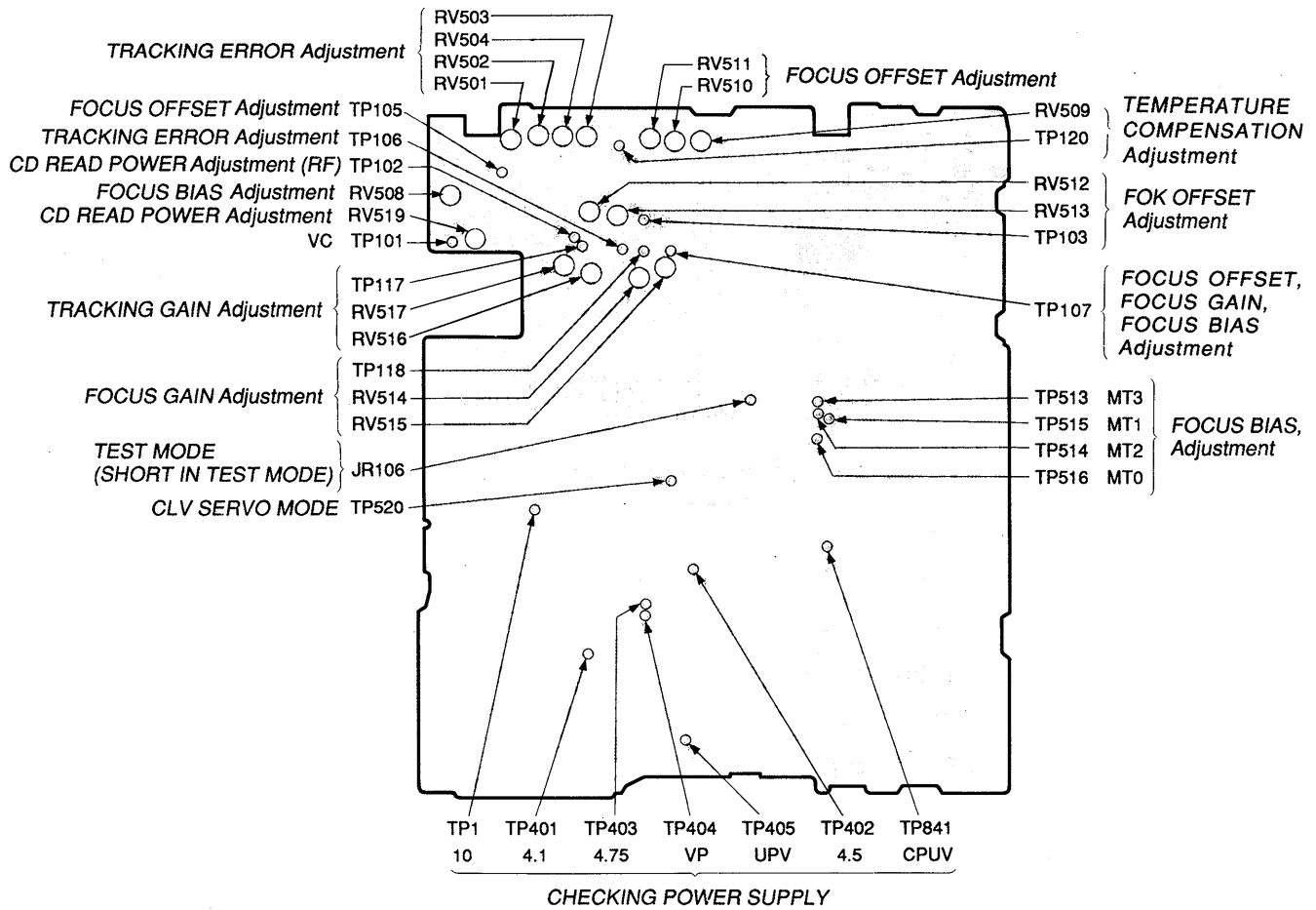

• Location of the last digit position

[MAIN BOARD] (SIDE-B)

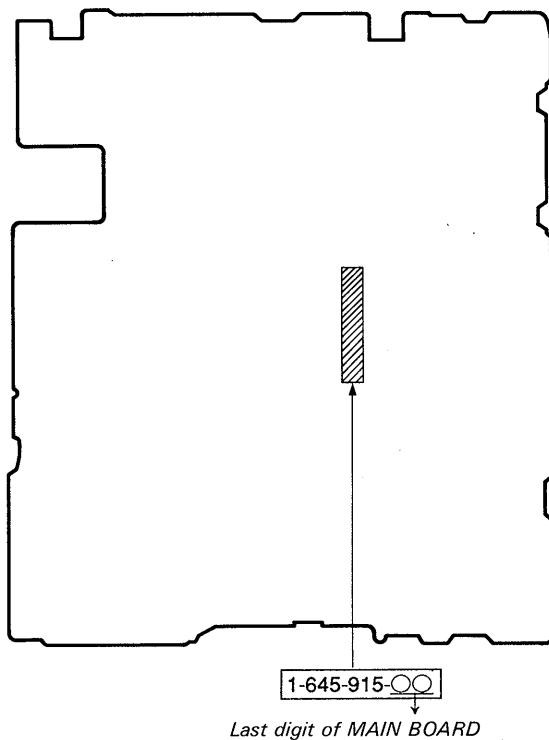

[CONTROL BOARD] (Component side)

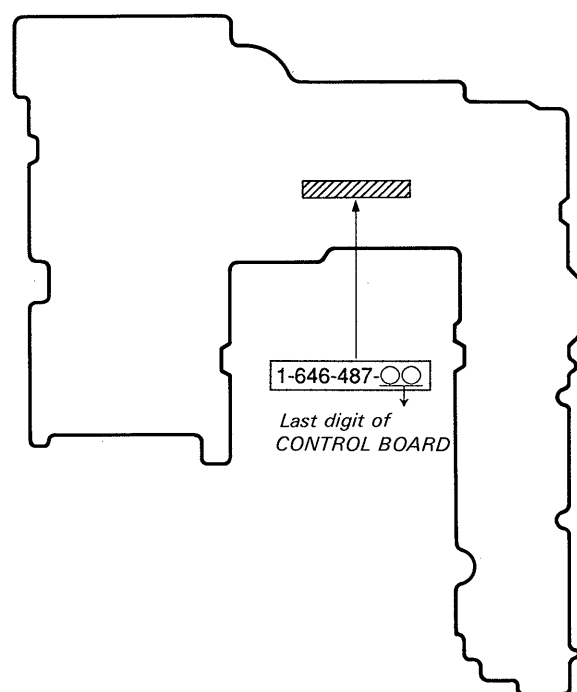

[PRINTED WIRING BOARD] (CONTROL Section)

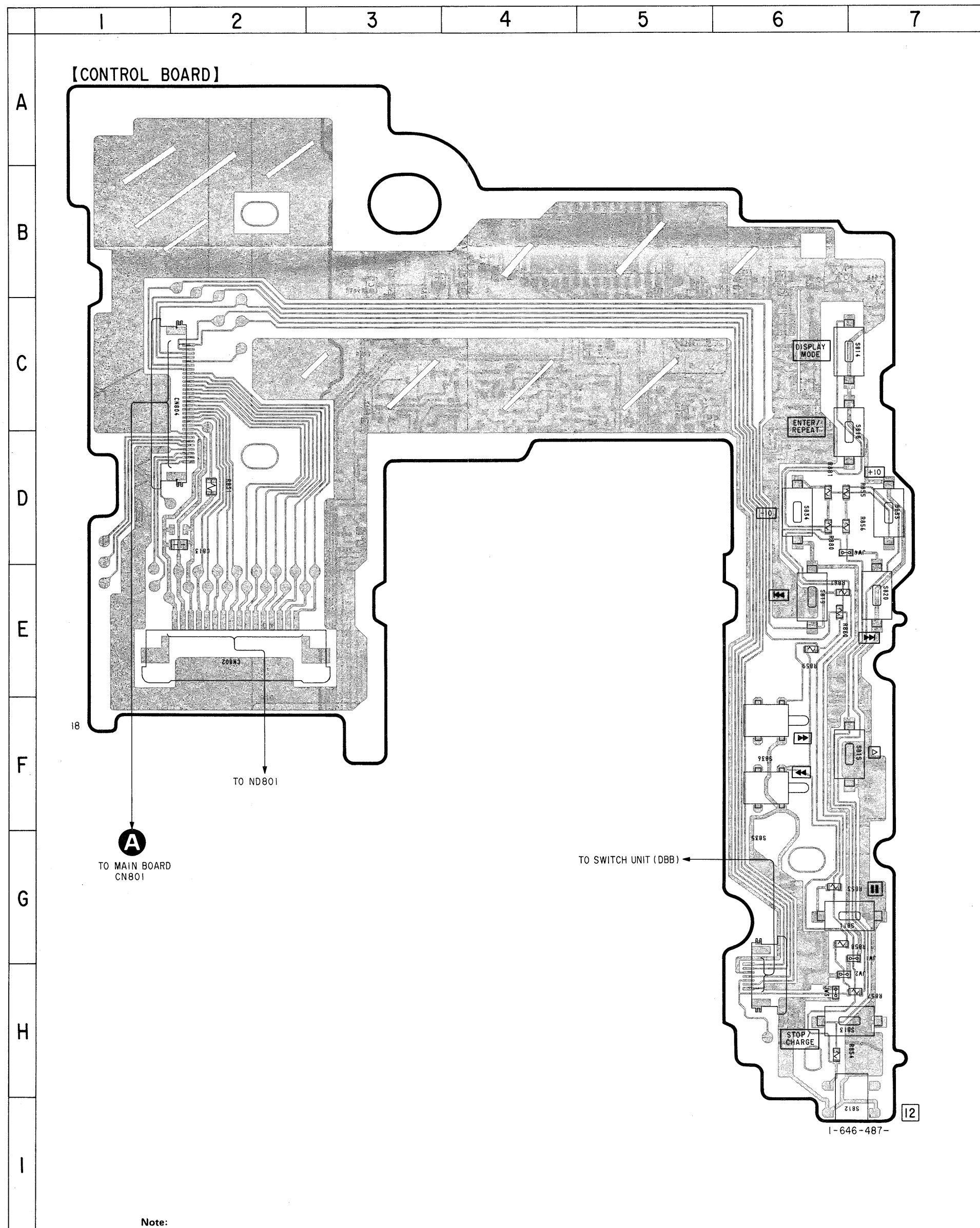

[SCHEMATIC DIAGRAM] (CONTROL Section)

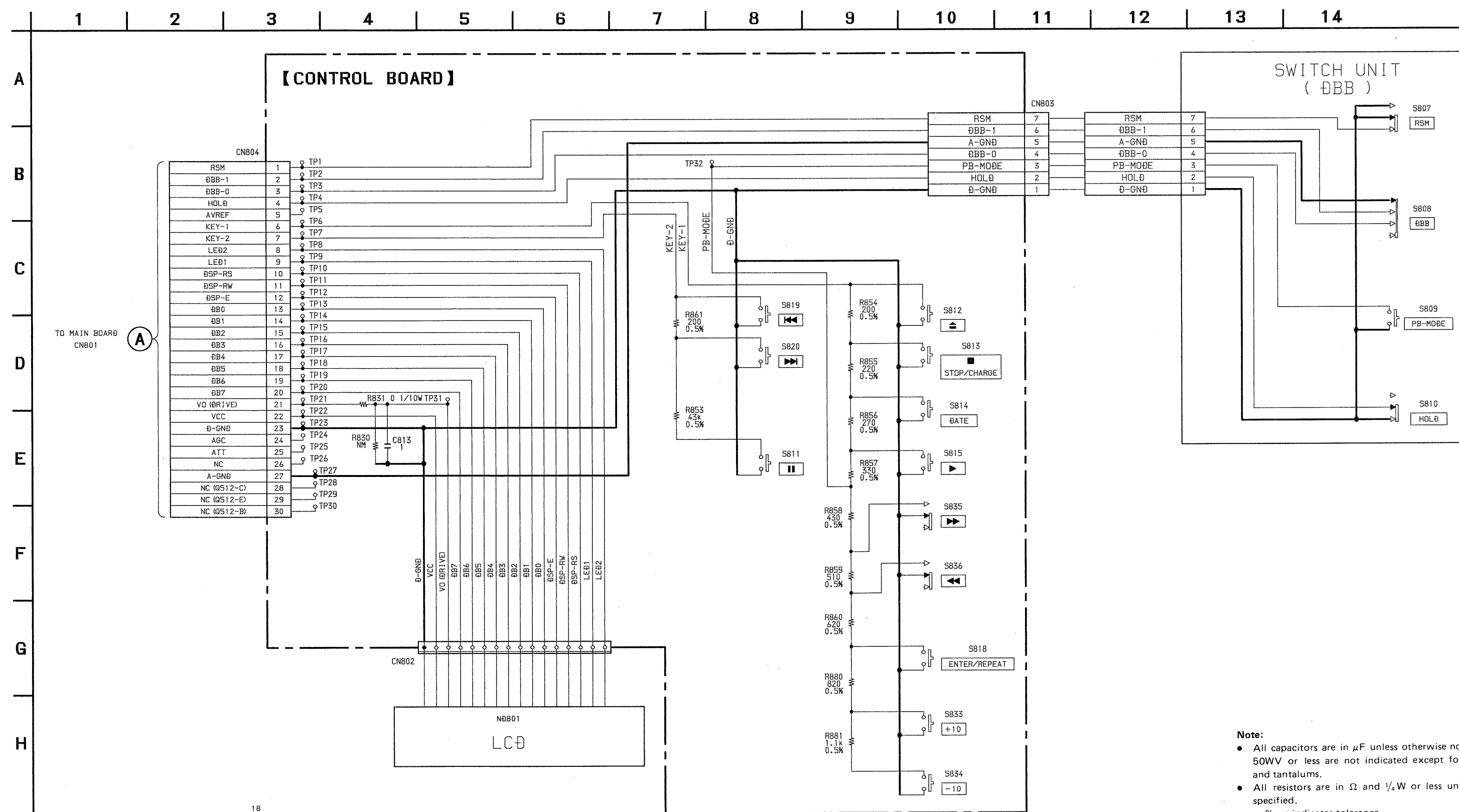

[BLOCK DIAGRAM]

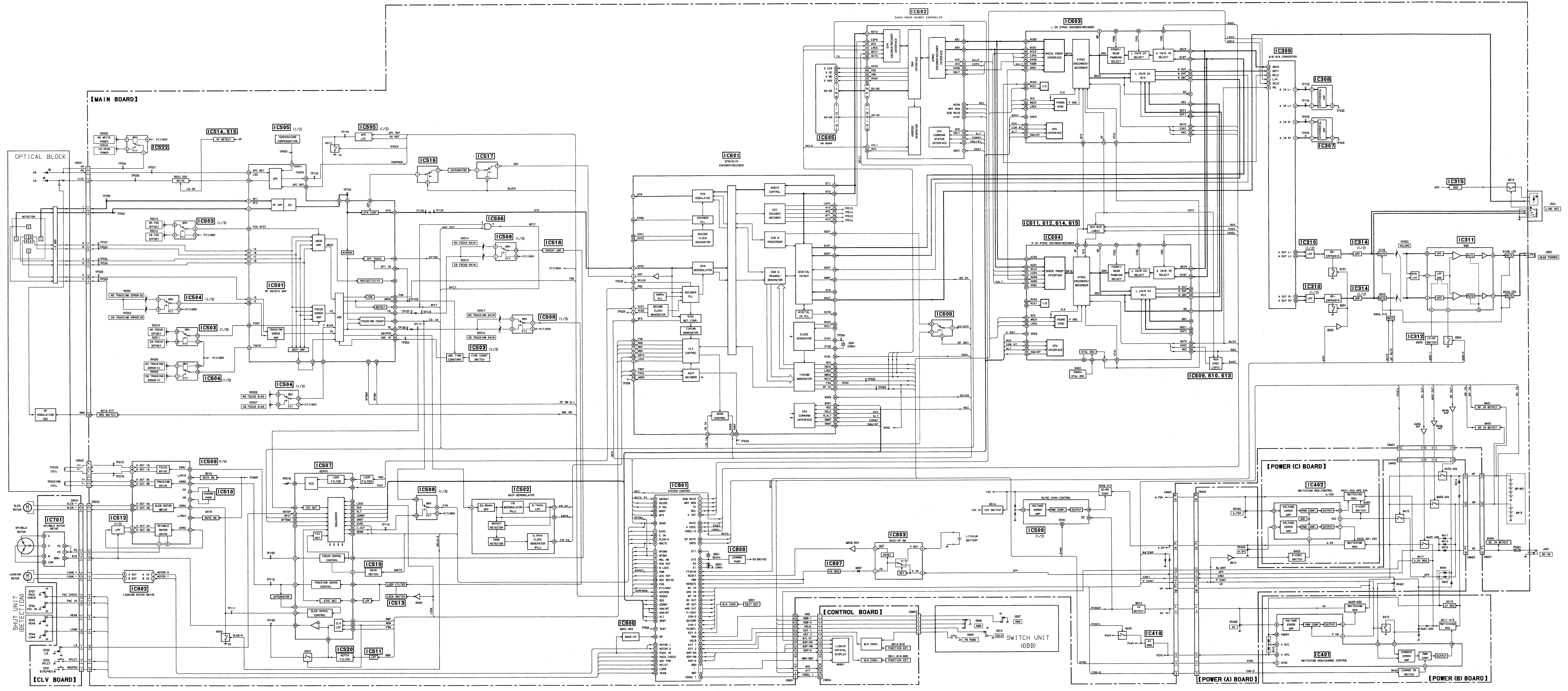

ELECTRICAL PARTS LIST

CONTROL

MAIN

NOTE:

- Due to standardization, replacements in the parts list may be different from the parts specified in the diagrams or the components used on the set.
- -XX and -X mean standardized parts, so they may have some difference from the original one.
- RESISTORS
All resistors are in ohms.
METAL: Metal-film resistor.
METAL OXIDE: Metal oxide-film resistor.
F: nonflammable

- Items marked "*" are not stocked since they are seldom required for routine service. Some delay should be anticipated when ordering these items.
- SEMICONDUCTORS
In each case, u: μ , for example:
uA .. μ A. uPA.. μ PA.
uPB.. μ PB. uPC.. μ PC. uPD.. μ PD.
- CAPACITORS
uF: μ F
- COILS
uH: μ H
- Abbreviations
AE5: means German and Swiss models.

The components identified by mark Δ or dotted line with mark Δ are critical for safety. Replace only with part number specified.

Les composants identifiés par une marque Δ sont critiques pour la sécurité. Ne les remplacer que par une pièce portant le numéro spécifié.

When indicating parts by reference number, please include the board.

Ref. No.	Part No.	Description	Remark
	A-3264-096-A	CONTROL BOARD, COMPELTE *****	
		< CAPACITOR >	
C813	1-164-346-11	CERAMIC CHIP 1uF	16V
		< CONNECTOR >	
CN802	1-566-532-11	CONNECTOR, FPC (ZIF) 16P	
CN803	1-573-916-11	CONNECTOR, FFC/FPC (ZIF) 7P	
CN804	1-573-370-21	CONNECTOR, FFC/FPC 30P	
		< JUMPER RESISTOR >	
JW1	1-216-864-11	METAL CHIP 0 5% 1/16W	
JW2	1-216-864-11	METAL CHIP 0 5% 1/16W	
JW3	1-216-864-11	METAL CHIP 0 5% 1/16W	
JW4	1-216-864-11	METAL CHIP 0 5% 1/16W	
		< RESISTOR >	
R831	1-216-295-00	METAL CHIP 0 5% 1/10W	
R853	1-216-830-11	METAL CHIP 5.6K 5% 1/16W	
R854	1-218-675-11	METAL CHIP 200 0.50% 1/16W	
R855	1-218-676-11	METAL CHIP 220 0.50% 1/16W	
R856	1-216-814-11	METAL CHIP 270 5% 1/16W	
R857	1-218-680-11	METAL CHIP 330 0.50% 1/16W	
R858	1-218-482-11	METAL CHIP 430 0.50% 1/16W	
R859	1-218-289-11	METAL CHIP 510 0.50% 1/16W	
R860	1-220-373-11	METAL CHIP 620 0.50% 1/16W	
R861	1-218-675-11	METAL CHIP 200 0.50% 1/16W	
R880	1-216-820-11	METAL CHIP 820 5% 1/16W	
R881	1-218-270-11	METAL CHIP 1.1K 0.50% 1/16W	
		< SWITCH >	
S811	1-572-473-11	SWITCH, TACTIL (II)	
S812	1-692-088-11	SWITCH, TACTIL (\triangle)	
S813	1-572-473-11	SWITCH, TACTIL (\blacksquare STOP/CHARGE)	
S814	1-572-473-11	SWITCH, TACTIL (DISPLAY MODE)	
S815	1-572-473-11	SWITCH, TACTIL (\blacktriangleright)	
S818	1-572-473-11	SWITCH, TACTIL (ENTER/REPEAT)	
S819	1-572-473-11	SWITCH, TACTIL (\blacktriangleleft /-)	

Ref. No.	Part No.	Description	Remark
S820	1-572-473-11	SWITCH, TACTIL (\blacktriangleright /+)	
S833	1-572-473-11	SWITCH, TACTIL (+10)	
S834	1-572-473-11	SWITCH, TACTIL (-10)	
S835	1-572-467-31	SWITCH, PUSH (1 KEY) (\blacktriangleleft)	
S836	1-572-467-31	SWITCH, PUSH (1 KEY) (\blacktriangleright)	

	A-3275-923-A	MAIN BOARD, COMPLETE (AE5)	
	A-3275-781-A	MAIN BOARD, COMPLETE (EXCEPT-AE5) *****	
	2-123-861-01	SCREW, TAPPING, P1.7X3	
	3-831-441-11	CUSHION (B)	
	4-955-523-01	HOLDER (TERMINAL)	
	4-955-524-01	CONTACT, PLUS	
	4-955-525-01	CONTACT, MINUS	
	4-955-534-01	TERMINAL BOARD	
	4-957-126-01	CUSHION (PC BOARD)	
		< CAPACITOR >	
C112	1-135-237-11	TANTAL. CHIP 2.2uF 20% 6.3V	
C113	1-135-263-21	TANTAL. CHIP 10uF 20% 10V	
C115	1-164-473-11	CERAMIC CHIP 820PF 10% 50V	
C116	1-162-927-11	CERAMIC CHIP 100PF 5% 50V	
C117	1-162-928-11	CERAMIC CHIP 120PF 5% 50V	
C118	1-162-928-11	CERAMIC CHIP 120PF 5% 50V	
C119	1-162-925-11	CERAMIC CHIP 68PF 5% 50V	
C120	1-162-925-11	CERAMIC CHIP 68PF 5% 50V	
C121	1-137-294-11	FILM CHIP 0.01uF 5% 16V	
C122	1-135-181-21	TANTALUM CHIP 4.7uF 20% 6.3V	
C123	1-135-091-00	TANTALUM CHIP 1uF 20% 16V	
C124	1-162-953-11	CERAMIC CHIP 100PF 5% 50V	
C125	1-162-966-11	CERAMIC CHIP 0.0022uF 10% 50V	
C126	1-135-335-11	TANTAL. CHIP 100uF 20% 4V	
C127	1-162-964-11	CERAMIC CHIP 0.001uF 10% 50V	
C128	1-135-335-11	TANTAL. CHIP 100uF 20% 4V	
C129	1-162-925-11	CERAMIC CHIP 68PF 5% 50V	
C130	1-162-924-11	CERAMIC CHIP 56PF 5% 50V	
C134	1-162-959-11	CERAMIC CHIP 330PF 5% 50V	
C135	1-135-263-21	TANTAL. CHIP 10uF 20% 10V	

MAIN

Ref. No.	Part No.	Description	Remark		
C136	1-135-237-11	TANTAL. CHIP	2. 2uF	20%	6. 3V
C137	1-162-957-11	CERAMIC CHIP	220PF	5%	50V
C138	1-162-922-11	CERAMIC CHIP	39PF	5%	50V
C141	1-162-964-11	CERAMIC CHIP	0. 001uF	10%	50V
C212	1-135-237-11	TANTAL. CHIP	2. 2uF	20%	6. 3V
C215	1-164-473-11	CERAMIC CHIP	820PF	10%	50V
C216	1-162-927-11	CERAMIC CHIP	100PF	5%	50V
C217	1-162-928-11	CERAMIC CHIP	120PF	5%	50V
C218	1-162-928-11	CERAMIC CHIP	120PF	5%	50V
C219	1-162-925-11	CERAMIC CHIP	68PF	5%	50V
C220	1-162-925-11	CERAMIC CHIP	68PF	5%	50V
C221	1-137-294-11	FILM CHIP	0. 01uF	5%	16V
C222	1-135-181-21	TANTALUM CHIP	4. 7uF	20%	6. 3V
C223	1-135-091-00	TANTALUM CHIP	1uF	20%	16V
C224	1-162-953-11	CERAMIC CHIP	100PF	5%	50V
C225	1-162-966-11	CERAMIC CHIP	0. 0022uF	10%	50V
C226	1-135-335-11	TANTAL. CHIP	100uF	20%	4V
C227	1-162-964-11	CERAMIC CHIP	0. 001uF	10%	50V
C228	1-135-335-11	TANTAL. CHIP	100uF	20%	4V
C229	1-162-925-11	CERAMIC CHIP	68PF	5%	50V
C230	1-162-924-11	CERAMIC CHIP	56PF	5%	50V
C234	1-162-959-11	CERAMIC CHIP	330PF	5%	50V
C235	1-135-263-21	TANTAL. CHIP	10uF	20%	10V
C236	1-135-237-11	TANTAL. CHIP	2. 2uF	20%	6. 3V
C237	1-162-957-11	CERAMIC CHIP	220PF	5%	50V
C238	1-162-922-11	CERAMIC CHIP	39PF	5%	50V
C241	1-162-964-11	CERAMIC CHIP	0. 001uF	10%	50V
C317	1-135-264-21	TANTAL. CHIP	22uF	20%	10V
C318	1-135-263-21	TANTAL. CHIP	10uF	20%	10V
C319	1-164-360-11	CERAMIC CHIP	0. 1uF		16V
C320	1-164-360-11	CERAMIC CHIP	0. 1uF		16V
C321	1-135-181-21	TANTALUM CHIP	4. 7uF	20%	6. 3V
C322	1-104-630-11	TANTAL. CHIP	33uF	20%	6. 3V
C323	1-164-360-11	CERAMIC CHIP	0. 1uF		16V
C324	1-164-360-11	CERAMIC CHIP	0. 1uF		16V
C325	1-135-263-21	TANTAL. CHIP	10uF	20%	10V
C326	1-164-360-11	CERAMIC CHIP	0. 1uF		16V
C327	1-104-630-11	TANTAL. CHIP	33uF	20%	6. 3V
C328	1-164-360-11	CERAMIC CHIP	0. 1uF		16V
C329	1-162-953-11	CERAMIC CHIP	100PF	5%	50V
C330	1-164-360-11	CERAMIC CHIP	0. 1uF		16V
C331	1-135-264-21	TANTAL. CHIP	22uF	20%	10V
C332	1-135-181-21	TANTALUM CHIP	4. 7uF	20%	6. 3V
C333	1-135-263-21	TANTAL. CHIP	10uF	20%	10V
C334	1-135-181-21	TANTALUM CHIP	4. 7uF	20%	6. 3V
C335	1-162-964-11	CERAMIC CHIP	0. 001uF	10%	50V
C336	1-164-360-11	CERAMIC CHIP	0. 1uF		16V
C337	1-164-489-11	CERAMIC CHIP	0. 22uF	10%	16V
C338	1-135-264-21	TANTAL. CHIP	22uF	20%	10V

Ref. No.	Part No.	Description	Remark		
C339	1-162-964-11	CERAMIC CHIP	0. 001uF	10%	50V
C341	1-135-264-21	TANTAL. CHIP	22uF	20%	10V
C342	1-162-964-11	CERAMIC CHIP	0. 001uF	10%	50V
C343	1-164-360-11	CERAMIC CHIP	0. 1uF		16V
C344	1-162-964-11	CERAMIC CHIP	0. 001uF	10%	50V
C345	1-135-240-21	TANTAL. CHIP	47uF	20%	10V
C350	1-164-361-11	CERAMIC CHIP	0. 047uF		16V
C351	1-104-630-11	TANTAL. CHIP	33uF	20%	6. 3V
C354	1-135-263-21	TANTAL. CHIP	10uF	20%	10V
C356	1-164-361-11	CERAMIC CHIP	0. 047uF		16V
C359	1-164-505-11	CERAMIC CHIP	2. 2uF		16V
C360	1-164-505-11	CERAMIC CHIP	2. 2uF		16V
C361	1-164-361-11	CERAMIC CHIP	0. 047uF		16V
C362	1-162-964-11	CERAMIC CHIP	0. 001uF	10%	50V
C363	1-162-970-11	CERAMIC CHIP	0. 01uF	10%	25V
C366	1-162-964-11	CERAMIC CHIP	0. 001uF	10%	50V
C401	1-126-949-75	ELECT	220uF	20%	35V
C470	1-164-505-11	CERAMIC CHIP	2. 2uF		16V
C471	1-164-505-11	CERAMIC CHIP	2. 2uF		16V
C472	1-162-970-11	CERAMIC CHIP	0. 01uF	10%	25V
C474	1-162-964-11	CERAMIC CHIP	0. 001uF	10%	25V (AE5)
C475	1-162-970-11	CERAMIC CHIP	0. 01uF	10%	25V (AE5)
C501	1-135-264-21	TANTAL. CHIP	22uF	20%	10V
C502	1-135-264-21	TANTAL. CHIP	22uF	20%	10V
C503	1-135-264-21	TANTAL. CHIP	22uF	20%	10V
C504	1-164-360-11	CERAMIC CHIP	0. 1uF		16V
C505	1-164-360-11	CERAMIC CHIP	0. 1uF		16V
C506	1-135-232-11	TANTAL. CHIP	10uF	20%	16V
C507	1-135-091-00	TANTALUM CHIP	1uF	20%	16V
C508	1-162-964-11	CERAMIC CHIP	0. 001uF	10%	50V
C509	1-135-264-21	TANTAL. CHIP	22uF	20%	10V
C510	1-162-970-11	CERAMIC CHIP	0. 01uF	10%	25V
C511	1-162-964-11	CERAMIC CHIP	0. 001uF	10%	50V
C512	1-164-490-11	CERAMIC CHIP	0. 068uF		16V
C513	1-162-964-11	CERAMIC CHIP	0. 001uF	10%	50V
C514	1-162-958-11	CERAMIC CHIP	270PF	5%	50V
C515	1-162-962-11	CERAMIC CHIP	470PF	10%	50V
C516	1-162-962-11	CERAMIC CHIP	470PF	10%	50V
C517	1-162-964-11	CERAMIC CHIP	0. 001uF	10%	50V
C518	1-162-958-11	CERAMIC CHIP	270PF	5%	50V
C519	1-135-264-21	TANTAL. CHIP	22uF	20%	10V
C520	1-162-964-11	CERAMIC CHIP	0. 001uF	10%	50V
C521	1-162-969-11	CERAMIC CHIP	0. 0068uF	10%	25V
C522	1-135-073-00	TANTALUM CHIP	0. 33uF	10%	35V
C523	1-164-360-11	CERAMIC CHIP	0. 1uF		16V
C524	1-164-677-11	CERAMIC CHIP	0. 033uF	10%	16V
C525	1-162-970-11	CERAMIC CHIP	0. 01uF	10%	25V
C526	1-164-005-11	CERAMIC CHIP	0. 47uF		25V
C527	1-162-979-11	CERAMIC CHIP	0. 0027uF	10%	50V

Ref. No.	Part No.	Description	Remark		
C529	1-162-966-11	CERAMIC CHIP	0.0022uF	10%	50V
C530	1-162-927-11	CERAMIC CHIP	100PF	5%	50V
C531	1-162-968-11	CERAMIC CHIP	0.0047uF	10%	50V
C532	1-135-264-21	TANTAL. CHIP	22uF	20%	10V
C533	1-135-264-21	TANTAL. CHIP	22uF	20%	10V
C534	1-164-490-11	CERAMIC CHIP	0.068uF		16V
C535	1-162-961-11	CERAMIC CHIP	330PF	10%	50V
C536	1-162-970-11	CERAMIC CHIP	0.01uF	10%	25V
C537	1-135-181-21	TANTALUM CHIP	4.7uF	20%	6.3V
C538	1-164-360-11	CERAMIC CHIP	0.1uF		16V
C539	1-164-360-11	CERAMIC CHIP	0.1uF		16V
C540	1-164-346-11	CERAMIC CHIP	1uF		16V
C541	1-162-970-11	CERAMIC CHIP	0.01uF	10%	25V
C542	1-164-346-11	CERAMIC CHIP	1uF		16V
C543	1-164-005-11	CERAMIC CHIP	0.47uF		25V
C544	1-164-005-11	CERAMIC CHIP	0.47uF		25V
C545	1-162-964-11	CERAMIC CHIP	0.001uF	10%	50V
C546	1-164-361-11	CERAMIC CHIP	0.047uF		16V
C547	1-162-953-11	CERAMIC CHIP	100PF	5%	50V
C548	1-164-005-11	CERAMIC CHIP	0.47uF		25V
C549	1-164-005-11	CERAMIC CHIP	0.47uF		25V
C550	1-164-677-11	CERAMIC CHIP	0.033uF	10%	16V
C551	1-162-952-11	CERAMIC CHIP	82PF	5%	50V
C552	1-164-360-11	CERAMIC CHIP	0.1uF		16V
C553	1-135-263-21	TANTAL. CHIP	10uF	20%	10V
C554	1-135-263-21	TANTAL. CHIP	10uF	20%	10V
C555	1-162-953-11	CERAMIC CHIP	100PF	5%	50V
C556	1-164-489-11	CERAMIC CHIP	0.22uF	10%	16V
C557	1-104-630-21	TANTAL. CHIP	33uF	20%	6.3V
C558	1-104-630-21	TANTAL. CHIP	33uF	20%	6.3V
C559	1-162-968-11	CERAMIC CHIP	0.0047uF	10%	50V
C561	1-135-264-21	TANTAL. CHIP	22uF	20%	10V
C563	1-164-361-11	CERAMIC CHIP	0.047uF		16V
C564	1-164-360-11	CERAMIC CHIP	0.1uF		16V
C565	1-162-964-11	CERAMIC CHIP	0.001uF	10%	50V
C567	1-164-361-11	CERAMIC CHIP	0.047uF		16V
C568	1-135-264-21	TANTAL. CHIP	22uF	20%	10V
C569	1-135-091-00	TANTALUM CHIP	1uF	20%	16V
C570	1-164-360-11	CERAMIC CHIP	0.1uF		16V
C571	1-164-346-11	CERAMIC CHIP	1uF		16V
C572	1-135-264-21	TANTAL. CHIP	22uF	20%	10V
C573	1-162-964-11	CERAMIC CHIP	0.001uF	10%	50V
C574	1-164-005-11	CERAMIC CHIP	0.47uF		25V
C578	1-164-677-11	CERAMIC CHIP	0.033uF	10%	16V
C579	1-135-224-11	TANTAL. CHIP	10uF	10%	25V
C580	1-162-964-11	CERAMIC CHIP	0.001uF	10%	50V
C581	1-135-263-21	TANTAL. CHIP	10uF	20%	10V
C582	1-135-208-11	TANTAL. CHIP	1uF	10%	10V

Ref. No.	Part No.	Description	Remark		
C583	1-135-263-21	TANTAL. CHIP	10uF	20%	10V
C584	1-163-986-00	CERAMIC CHIP	0.027uF	10%	25V
C586	1-164-360-11	CERAMIC CHIP	0.1uF		16V
C587	1-164-346-11	CERAMIC CHIP	1uF		16V
C589	1-164-346-11	CERAMIC CHIP	1uF		16V
C590	1-164-346-11	CERAMIC CHIP	1uF		16V
C591	1-164-360-11	CERAMIC CHIP	0.1uF		16V
C592	1-164-346-11	CERAMIC CHIP	1uF		16V
C594	1-135-264-21	TANTAL. CHIP	22uF	20%	10V
C595	1-135-264-21	TANTAL. CHIP	22uF	20%	10V
C596	1-135-208-11	TANTAL. CHIP	1uF	10%	10V
C597	1-135-263-21	TANTAL. CHIP	10uF	20%	10V
C598	1-162-960-11	CERAMIC CHIP	220PF	10%	50V
C599	1-135-232-11	TANTAL. CHIP	10uF	20%	16V
C608	1-162-970-11	CERAMIC CHIP	0.01uF	10%	25V
C616	1-164-360-11	CERAMIC CHIP	0.1uF		16V
C617	1-104-629-11	TANTAL. CHIP	15uF	20%	6.3V
C618	1-135-264-21	TANTAL. CHIP	22uF	20%	10V
C620	1-162-917-11	CERAMIC CHIP	15PF	5%	50V
C621	1-162-917-11	CERAMIC CHIP	15PF	5%	50V
C622	1-135-264-21	TANTAL. CHIP	22uF	20%	10V
C623	1-162-970-11	CERAMIC CHIP	0.01uF	10%	25V
C624	1-163-986-00	CERAMIC CHIP	0.027uF	10%	25V
C626	1-164-005-11	CERAMIC CHIP	0.47uF		25V
C627	1-162-970-11	CERAMIC CHIP	0.01uF	10%	25V
C628	1-162-970-11	CERAMIC CHIP	0.01uF	10%	25V
C629	1-162-970-11	CERAMIC CHIP	0.01uF	10%	25V
C630	1-162-970-11	CERAMIC CHIP	0.01uF	10%	25V
C631	1-162-970-11	CERAMIC CHIP	0.01uF	10%	25V
C632	1-162-970-11	CERAMIC CHIP	0.01uF	10%	25V
C633	1-162-970-11	CERAMIC CHIP	0.01uF	10%	25V
C634	1-162-970-11	CERAMIC CHIP	0.01uF	10%	25V
C635	1-162-970-11	CERAMIC CHIP	0.01uF	10%	25V
C636	1-162-970-11	CERAMIC CHIP	0.01uF	10%	25V
C637	1-162-970-11	CERAMIC CHIP	0.01uF	10%	25V
C638	1-162-970-11	CERAMIC CHIP	0.01uF	10%	25V
C639	1-162-970-11	CERAMIC CHIP	0.01uF	10%	25V
C640	1-162-970-11	CERAMIC CHIP	0.01uF	10%	25V
C641	1-162-970-11	CERAMIC CHIP	0.01uF	10%	25V
C642	1-164-360-11	CERAMIC CHIP	0.1uF		16V
C643	1-162-970-11	CERAMIC CHIP	0.01uF	10%	25V
C652	1-162-962-11	CERAMIC CHIP	470PF	10%	50V
C801	1-164-360-11	CERAMIC CHIP	0.1uF		16V
C802	1-162-915-11	CERAMIC CHIP	10PF	0.5PF	50V
C803	1-162-915-11	CERAMIC CHIP	10PF	0.5PF	50V
C807	1-164-360-11	CERAMIC CHIP	0.1uF		16V
C808	1-164-360-11	CERAMIC CHIP	0.1uF		16V
C809	1-135-264-21	TANTAL. CHIP	22uF	20%	10V

MAIN

Ref. No.	Part No.	Description	Remark		
C810	1-164-346-11	CERAMIC CHIP	1uF		16V
C811	1-164-360-11	CERAMIC CHIP	0.1uF		16V
C812	1-164-346-11	CERAMIC CHIP	1uF		16V
C814	1-164-346-11	CERAMIC CHIP	1uF		16V
C816	1-135-334-11	TANTAL. CHIP	100uF	20%	6.3V
C817	1-164-505-11	CERAMIC CHIP	2.2uF		16V
C818	1-135-263-21	TANTAL. CHIP	10uF	20%	10V
C820	1-135-263-21	TANTAL. CHIP	10uF	20%	10V
C821	1-135-181-21	TANTALUM CHIP	4.7uF	20%	6.3V
C822	1-162-970-11	CERAMIC CHIP	0.01uF	10%	25V
C826	1-164-505-11	CERAMIC CHIP	2.2uF		16V
C827	1-164-346-11	CERAMIC CHIP	1uF		16V
C828	1-164-360-11	CERAMIC CHIP	0.1uF		16V
C829	1-135-263-21	TANTAL. CHIP	10uF	20%	10V
C830	1-164-346-11	CERAMIC CHIP	1uF		16V
C831	1-162-962-11	CERAMIC CHIP	470pF	10%	50V
C832	1-162-962-11	CERAMIC CHIP	470pF	10%	50V
C833	1-162-962-11	CERAMIC CHIP	470pF	10%	50V
C925	1-135-263-21	TANTALUM CHIP	10uF	20%	10V
C5001	1-162-961-11	CERAMIC CHIP	330PF	10%	50V
C5012	1-164-346-11	CERAMIC CHIP	1uF		16V
C5013	1-164-245-11	CERAMIC CHIP	0.015uF	10%	25V
C5014	1-164-245-11	CERAMIC CHIP	0.015uF	10%	25V
C5015	1-162-970-11	CERAMIC CHIP	0.01uF	10%	25V
C5016	1-164-360-11	CERAMIC CHIP	0.1uF		16V
C5017	1-164-360-11	CERAMIC CHIP	0.1uF		16V
C5018	1-135-334-11	TANTAL. CHIP	100uF	20%	6.3V
C5019	1-135-334-11	TANTAL. CHIP	100uF	20%	6.3V
C5020	1-135-334-11	TANTAL. CHIP	100uF	20%	6.3V
C5022	1-164-363-11	CERAMIC CHIP	560PF	5%	50V
C5023	1-162-970-11	CERAMIC CHIP	0.01uF	10%	25V
C5025	1-162-970-11	CERAMIC CHIP	0.01uF	10%	25V
C5026	1-162-962-11	CERAMIC CHIP	470PF	10%	50V
C5031	1-162-965-11	CERAMIC CHIP	0.0015uF	10%	50V
C5032	1-162-953-11	CERAMIC CHIP	100PF	5%	50V
C5033	1-164-677-11	CERAMIC CHIP	0.033uF	10%	16V
C5034	1-162-970-11	CERAMIC CHIP	0.01uF	10%	25V
C5035	1-162-964-11	CERAMIC CHIP	0.001uF	10%	50V
C5036	1-162-964-11	CERAMIC CHIP	0.001uF	10%	50V
C5037	1-162-966-11	CERAMIC CHIP	0.0022uF	10%	50V
C5038	1-162-964-11	CERAMIC CHIP	0.001uF	10%	50V
C5039	1-162-970-11	CERAMIC CHIP	0.01uF	10%	25V
C5046	1-162-964-11	CERAMIC CHIP	0.001uF	10%	50V
C5047	1-162-964-11	CERAMIC CHIP	0.001uF	10%	50V
C5048	1-164-004-11	CERAMIC CHIP	0.1uF	10%	25V
C5050	1-162-970-11	CERAMIC CHIP	0.01uF	10%	25V
C5052	1-162-970-11	CERAMIC CHIP	0.01uF	10%	25V
C5053	1-162-970-11	CERAMIC CHIP	0.01uF	10%	25V
C5054	1-164-360-11	CERAMIC CHIP	0.1uF		16V

Ref. No.	Part No.	Description	Remark		
C5055	1-135-091-00	CERAMIC CHIP	1uF	20%	16V
C5056	1-162-969-11	CERAMIC CHIP	0.0068uF	10%	25V
C5057	1-135-237-11	TANTAL. CHIP	2.2uF	20%	6.3V
C5059	1-163-809-11	CERAMIC CHIP	0.047uF	10%	25V

< CONNECTOR >

CN401	1-573-315-21	CONNECTOR, BOARD TO BOARD	30P		
CN501	1-573-927-11	CONNECTOR, FFC/FPC (ZIF)	18P		
CN502	1-573-355-11	CONNECTOR, FFC/FPC	15P		
CN503	1-573-346-21	CONNECTOR, FFC/FPC	6P		
CN801	1-573-370-21	CONNECTOR, FFC/FPC	30P		

< DIODE >

D301	8-719-941-23	DIODE	DA204U		
D307	8-719-941-86	DIODE	DAN202U		
D311	8-719-941-09	DIODE	DAP202U		
D401	8-719-974-51	DIODE	SB20-03P		
D406	8-719-941-86	DIODE	DAN202U		
D420	8-719-106-88	DIODE	RD15M-B1		
D421	8-719-106-88	DIODE	RD15M-B1		
D422	8-719-106-88	DIODE	RD15M-B1		
D423	8-719-106-88	DIODE	RD15M-B1		
D424	8-719-404-46	DIODE	MA110		
D502	8-719-420-51	DIODE	MA729		
D503	8-719-938-78	DIODE	SB10-05PCP		
D504	8-719-023-69	DIODE	SB007T03Q		
D505	8-719-024-10	DIODE	SB007-03Q		
D506	8-719-941-23	DIODE	DA204U		
D507	8-719-420-51	DIODE	MA729		
D515	8-719-941-23	DIODE	DA204U		
D803	8-719-941-09	DIODE	DAP202U		
D804	8-719-941-86	DIODE	DAN202U		
D806	8-719-420-51	DIODE	MA729		
D807	8-719-938-75	DIODE	SB05-05CP		
D808	8-719-938-75	DIODE	SB05-05CP		
D810	8-719-420-51	DIODE	MA729		
D811	8-719-420-51	DIODE	MA729		
D812	8-719-941-23	DIODE	DA204U		

< FERRITE BEAD >

FB301	1-543-949-11	BEAD, FERRITE (CHIP)			
FB302	1-543-949-11	BEAD, FERRITE (CHIP)			
FB303	1-543-949-11	BEAD, FERRITE (CHIP)			
FB310	1-543-949-11	BEAD, FERRITE (CHIP)			
FB315	1-543-949-11	BEAD, FERRITE (CHIP)	(EXCEPT AE5)		
FB316	1-543-949-11	BEAD, FERRITE (CHIP)	(EXCEPT AE5)		
FB501	1-543-949-11	BEAD, FERRITE (CHIP)			
FB603	1-543-949-11	BEAD, FERRITE (CHIP)			
FB604	1-543-949-11	BEAD, FERRITE (CHIP)			
FB606	1-543-949-11	BEAD, FERRITE (CHIP)			

Ref. No.	Part No.	Description	Remark
FB607	1-543-949-11	BEAD, FERRITE (CHIP)	
FB608	1-543-949-11	BEAD, FERRITE (CHIP)	
FB609	1-543-949-11	BEAD, FERRITE (CHIP)	
FB610	1-543-949-11	BEAD, FERRITE (CHIP)	
< IC >			
IC307	8-759-097-92	IC NJM2100V	
IC308	8-759-097-92	IC NJM2100V	
IC309	8-759-085-06	IC AK4501-VS	
IC310	8-759-097-92	IC NJM2100V	
IC311	8-759-510-56	IC BA3570FS	
IC312	8-759-234-77	IC TC4S66F	
IC314	8-759-097-92	IC NJM2100V	
IC315	8-759-161-52	IC S-81250PG-PD-S	
IC410	8-759-161-50	IC S-81240PG-PJ-S	
IC501	8-752-064-34	IC CXA1381R	
IC502	8-752-064-33	IC CXA1380N	
IC503	8-759-053-34	IC uPD74HC4053G	
IC504	8-759-053-34	IC uPD74HC4053G	
IC505	8-759-080-34	IC TA75W01FU	
IC506	8-759-035-26	IC SC7S08F	
IC507	8-752-055-94	IC CXA1602R	
IC508	8-759-053-34	IC uPD74HC4053G	
IC509	8-759-084-72	IC MPC1718FU	
IC510	8-759-031-84	IC SC7S04F	
IC511	8-759-710-79	IC NJM2107F	
IC512	8-759-710-79	IC NJM2107F	
IC513	8-759-234-77	IC TC4S66F	
IC514	8-759-087-73	IC S-80745AN-D9	
IC515	8-759-234-20	IC TC7S08F	
IC516	8-759-082-61	IC TC4W53FU	
IC517	8-759-082-61	IC TC4W53FU	
IC518	8-759-710-79	IC NJM2107F	
IC519	8-759-234-77	IC TC4S66F	
IC520	8-759-710-79	IC NJM2107F	
IC522	8-759-082-61	IC TC4W53FU	
IC601	8-752-352-18	IC CXD2525R	
IC602	8-752-354-57	IC CXD2526Q	
IC603	8-752-356-18	IC CXD2527R-1	
IC604	8-752-355-96	IC CXD2527R	
IC605	8-759-160-77	IC MS514400AL-80VC	
IC606	8-759-082-61	IC TC4W53FU-TE12R	
IC609	8-759-083-94	IC TC7W74FU-TE12R	
IC610	8-759-234-20	IC TC7S08F	
IC611	8-759-031-84	IC SC7S04F	
IC612	8-759-083-94	IC TC7W74FU-TE12R	
IC613	8-759-035-93	IC SC7S32FER	
IC614	8-759-035-26	IC SC7S08F	
IC615	8-759-035-93	IC SC7S32FER	

Ref. No.	Part No.	Description	Remark
IC801	8-752-842-14	IC CXP817P40Q-1-000	
IC802	8-759-908-81	IC MB3763PF	
IC803	8-759-056-84	IC S-8420AF	
IC806	8-759-031-84	IC SC7S04F	
IC807	8-759-161-50	IC S-81240PG-PJ-T1	
IC808	8-759-031-84	IC SC7S04F	
< JACK >			
J303	1-569-809-11	JACK (SMALL TYPE) (◇)	
J304	8-749-923-96	IC GP1F351T (OPTICAL (DIGITAL)/LINE OUT)	
J401	1-580-428-11	JACK, DC (DC IN 10.5V)	
< COIL >			
L101	1-412-979-21	INDUCTOR CHIP 1uH	
L102	1-412-979-21	INDUCTOR CHIP 1uH	
L301	1-412-029-11	INDUCTOR CHIP 10uH	
L302	1-412-032-11	INDUCTOR CHIP 100uH	
L303	1-412-032-11	INDUCTOR CHIP 100uH	
L304	1-412-029-11	INDUCTOR CHIP 10uH	
L306	1-410-997-31	INDUCTOR CHIP 2.2uH	
L307	1-412-997-21	INDUCTOR CHIP 33uH	
L308	1-412-997-21	INDUCTOR CHIP 33uH	
L309	1-412-979-21	INDUCTOR CHIP 1uH	
L501	1-412-029-11	INDUCTOR CHIP 10uH	
L502	1-412-029-11	INDUCTOR CHIP 10uH	
L503	1-412-029-11	INDUCTOR CHIP 10uH	
L504	9-910-999-33	INDUCTOR 560UH	
L505	1-414-203-11	INDUCTOR 100uH	
L506	1-414-203-11	INDUCTOR 100uH	
L507	1-414-203-11	INDUCTOR 100uH	
L508	1-414-203-11	INDUCTOR 100uH	
L510	1-412-011-31	INDUCTOR CHIP 27uH	
L601	1-412-029-11	INDUCTOR CHIP 10uH	
L602	1-412-029-11	INDUCTOR CHIP 10uH	
L605	1-412-029-11	INDUCTOR CHIP 10uH	
L606	1-412-029-11	INDUCTOR CHIP 10uH	
< LINE FILTER >			
LF302	1-402-984-21	FILTER, COMMON MODE	
LF304	1-402-984-21	FILTER, COMMON MODE	
LF401	1-402-951-11	COIL, LINE FILTER	
< IC LINK >			
△PS401	1-533-282-21	LINK, IC	
< TRANSISTOR >			
Q101	8-729-144-16	TRANSISTOR 2SD2228-D44D45	
Q102	8-729-144-16	TRANSISTOR 2SD2228-D44D45	

The components identified by mark △ or dotted line with mark △ are critical for safety. Replace only with part number specified.	Les composants identifiés par une marque △ sont critiques pour la sécurité. Ne les remplacer que par une pièce portant le numéro spécifié.
--	--

MAIN

Ref. No.	Part No.	Description	Remark	Ref. No.	Part No.	Description	Remark
Q103	8-729-144-16	TRANSISTOR	2SD2228-D44D45	R119	1-216-821-11	METAL CHIP	1K 5% 1/16W
Q105	8-729-144-16	TRANSISTOR	2SD2228-D44D45	R120	1-218-724-11	METAL CHIP	22K 0.50% 1/16W
Q201	8-729-144-16	TRANSISTOR	2SD2228-D44D45	R121	1-218-724-11	METAL CHIP	22K 0.50% 1/16W
Q202	8-729-144-16	TRANSISTOR	2SD2228-D44D45	R122	1-218-724-11	METAL CHIP	22K 0.50% 1/16W
Q203	8-729-144-16	TRANSISTOR	2SD2228-D44D45	R123	1-218-724-11	METAL CHIP	22K 0.50% 1/16W
Q205	8-729-144-16	TRANSISTOR	2SD2228-D44D45	R124	1-218-883-11	METAL CHIP	33K 0.50% 1/16W
Q302	8-729-907-39	TRANSISTOR	IMD2	R125	1-218-883-11	METAL CHIP	33K 0.50% 1/16W
Q303	8-729-906-33	TRANSISTOR	DTC114YU	R126	1-218-736-11	METAL CHIP	68K 0.50% 1/16W
Q304	8-729-906-33	TRANSISTOR	DTC114YU	R127	1-218-736-11	METAL CHIP	68K 0.50% 1/16W
Q306	8-729-907-39	TRANSISTOR	IMD2	R128	1-218-705-11	METAL CHIP	3.6K 0.50% 1/16W
Q310	8-729-402-84	TRANSISTOR	XN4601	R129	1-216-823-11	METAL CHIP	1.5K 5% 1/16W
Q312	8-729-924-31	TRANSISTOR	DTA114WU	R130	1-216-857-11	METAL CHIP	1M 5% 1/16W
Q401	8-729-421-71	TRANSISTOR	2SK620	R131	1-216-833-11	METAL CHIP	10K 5% 1/16W
Q402	8-729-421-71	TRANSISTOR	2SK620	R132	1-216-813-11	METAL CHIP	220 5% 1/16W
Q409	8-729-907-00	TRANSISTOR	DTC114EU	R133	1-216-829-11	METAL CHIP	4.7K 5% 1/16W
Q445	8-729-924-31	TRANSISTOR	DTA114WU	R134	1-218-724-11	METAL CHIP	22K 0.50% 1/16W
Q446	8-729-905-12	TRANSISTOR	DTA144EU	R135	1-216-833-11	METAL CHIP	10K 5% 1/16W
Q447	8-729-924-65	TRANSISTOR	DTC123YU	R136	1-216-800-11	METAL GLAZE	18 5% 1/16W
Q448	8-729-905-12	TRANSISTOR	DTA144EU	R137	1-216-821-11	METAL CHIP	1K 5% 1/16W
Q449	8-729-924-65	TRANSISTOR	DTC123YU	R138	1-216-799-11	METAL CHIP	15 5% 1/16W
Q450	8-729-905-12	TRANSISTOR	DTA144EU	R146	1-216-845-11	METAL CHIP	100K 5% 1/16W
Q451	8-729-924-65	TRANSISTOR	DTC123YU	R147	1-216-815-11	METAL CHIP	330 5% 1/16W
Q452	8-729-905-18	TRANSISTOR	DTC144EU	R149	1-218-704-11	METAL CHIP	3.3K 0.50% 1/16W
Q501	8-729-101-07	TRANSISTOR	2SB798-DL	R150	1-216-842-11	METAL CHIP	56K 5% 1/16W
Q502	8-729-216-22	TRANSISTOR	2SA1162-G	R156	1-216-833-11	METAL CHIP	10K 5% 1/16W
Q503	8-729-922-10	TRANSISTOR	2SA1577-QR	R157	1-216-829-11	METAL CHIP	4.7K 5% 1/16W
Q506	8-729-905-61	TRANSISTOR	DTC124EU	R158	1-218-740-11	METAL CHIP	100K 0.50% 1/16W
Q508	8-729-420-74	TRANSISTOR	2SD1328-RST	R159	1-216-829-11	METAL CHIP	4.7K 5% 1/16W
Q509	8-729-905-61	TRANSISTOR	DTC124EU	R162	1-216-864-11	METAL CHIP	0 5% 1/16W
Q510	8-729-905-12	TRANSISTOR	DTA144EU	R214	1-218-740-11	METAL CHIP	100K 0.50% 1/16W
Q513	8-729-402-84	TRANSISTOR	XN4601	R215	1-218-721-11	METAL CHIP	16K 0.50% 1/16W
Q514	8-729-922-10	TRANSISTOR	2SA1577-QR	R216	1-216-795-11	METAL CHIP	6.8K 0.50% 1/16W
Q516	8-729-924-68	TRANSISTOR	DTC114WU	R217	1-218-716-11	METAL CHIP	10K 0.50% 1/16W
Q517	8-729-906-33	TRANSISTOR	DTC114YU	R218	1-216-821-11	METAL CHIP	1K 5% 1/16W
Q518	8-729-120-28	TRANSISTOR	2SC1623-L5L6	R219	1-216-821-11	METAL CHIP	1K 5% 1/16W
Q519	8-729-120-28	TRANSISTOR	2SC1623-L5L6	R220	1-218-724-11	METAL CHIP	22K 0.50% 1/16W
Q801	8-729-905-12	TRANSISTOR	DTA144EU	R221	1-218-724-11	METAL CHIP	22K 0.50% 1/16W
Q802	8-729-906-33	TRANSISTOR	DTC114YU	R222	1-218-724-11	METAL CHIP	22K 0.50% 1/16W
Q803	8-729-905-18	TRANSISTOR	DTC144EU	R223	1-218-724-11	METAL CHIP	22K 0.50% 1/16W
Q804	8-729-922-10	TRANSISTOR	2SA1577-QR	R224	1-218-883-11	METAL CHIP	33K 0.50% 1/16W
Q807	8-729-905-12	TRANSISTOR	DTA144EU	R225	1-218-883-11	METAL CHIP	33K 0.50% 1/16W
< RESISTOR >				R226	1-218-736-11	METAL CHIP	68K 0.50% 1/16W
R114	1-218-740-11	METAL CHIP	100K 0.50% 1/16W	R227	1-218-736-11	METAL CHIP	68K 0.50% 1/16W
R115	1-218-721-11	METAL CHIP	16K 0.50% 1/16W	R228	1-218-705-11	METAL CHIP	3.6K 0.50% 1/16W
R116	1-216-795-11	METAL CHIP	6.8K 0.50% 1/16W	R229	1-216-823-11	METAL CHIP	1.5K 5% 1/16W
R117	1-218-716-11	METAL CHIP	10K 0.50% 1/16W	R230	1-216-857-11	METAL CHIP	1M 5% 1/16W
R118	1-216-821-11	METAL CHIP	1K 5% 1/16W	R231	1-216-833-11	METAL CHIP	10K 5% 1/16W
				R232	1-216-813-11	METAL CHIP	220 5% 1/16W
				R233	1-216-829-11	METAL CHIP	4.7K 5% 1/16W

Ref. No.	Part No.	Description	Remark		
R234	1-218-724-11	METAL CHIP	22K	0.50%	1/16W
R235	1-216-833-11	METAL CHIP	10K	5%	1/16W
R236	1-216-800-11	METAL CHIP	18	5%	1/16W
R237	1-216-821-11	METAL CHIP	1K	5%	1/16W
R238	1-216-799-11	METAL CHIP	15	5%	1/16W
R246	1-216-845-11	METAL CHIP	100K	5%	1/16W
R247	1-216-815-11	METAL CHIP	330	5%	1/16W
R249	1-218-704-11	METAL CHIP	3.3K	0.50%	1/16W
R250	1-216-842-11	METAL CHIP	56K	5%	1/16W
R256	1-216-833-11	METAL CHIP	10K	5%	1/16W
R257	1-216-829-11	METAL CHIP	4.7K	5%	1/16W
R258	1-218-740-11	METAL CHIP	100K	0.50%	1/16W
R259	1-216-829-11	METAL CHIP	4.7K	5%	1/16W
R262	1-216-864-11	METAL CHIP	0	5%	1/16W
R317	1-216-864-11	METAL CHIP	0	5%	1/16W
R318	1-216-825-11	METAL CHIP	2.2K	5%	1/16W
R319	1-216-825-11	METAL CHIP	2.2K	5%	1/16W
R320	1-216-864-11	METAL CHIP	0	5%	1/16W
R321	1-216-833-11	METAL CHIP	10K	5%	1/16W
R322	1-216-833-11	METAL CHIP	10K	5%	1/16W
R323	1-216-833-11	METAL CHIP	10K	5%	1/16W
R324	1-216-833-11	METAL CHIP	10K	5%	1/16W
R325	1-216-857-11	METAL CHIP	1M	5%	1/16W
R330	1-216-864-11	METAL CHIP	0	5%	1/16W
R333	1-216-822-11	METAL CHIP	1.2K	5%	1/16W
R334	1-216-829-11	METAL CHIP	4.7K	5%	1/16W
R336	1-216-864-11	METAL CHIP	0	5%	1/16W
R338	1-216-864-11	METAL CHIP	0	5%	1/16W
R339	1-216-829-11	METAL CHIP	4.7K	5%	1/16W
R340	1-216-845-11	METAL CHIP	100K	5%	1/16W
R341	1-216-845-11	METAL CHIP	100K	5%	1/16W
R342	1-216-823-11	METAL CHIP	1.5K	5%	1/16W
R343	1-216-841-11	METAL CHIP	47K	5%	1/16W
R354	1-216-864-11	METAL GLAZE	0	5%	1/16W
R359	1-216-864-11	METAL GLAZE	0	5%	1/16W (AE5)
R360	1-216-864-11	METAL GLAZE	0	5%	1/16W (AE5)
R366	1-216-825-11	METAL CHIP	2.2K	5%	1/16W
R367	1-216-825-11	METAL CHIP	2.2K	5%	1/16W
R369	1-216-833-11	METAL CHIP	10K	5%	1/16W
R370	1-216-830-11	METAL CHIP	5.6K	5%	1/16W
R371	1-216-821-11	METAL CHIP	1K	5%	1/16W
R372	1-216-841-11	METAL CHIP	47K	5%	1/16W
R373	1-216-845-11	METAL CHIP	100K	5%	1/16W
R374	1-216-833-11	METAL CHIP	10K	5%	1/16W
R375	1-216-851-11	METAL CHIP	330K	5%	1/16W
R376	1-216-845-11	METAL CHIP	100K	5%	1/16W
R387	1-216-864-11	METAL CHIP	0	5%	1/16W
R389	1-216-864-11	METAL CHIP	0	5%	1/16W

Ref. No.	Part No.	Description	Remark		
R383	1-216-845-11	METAL CHIP	100K	5%	1/16W
R384	1-216-864-11	METAL CHIP	0	5%	1/16W
R402	1-216-841-11	METAL CHIP	47K	5%	1/16W
R441	1-216-864-11	METAL CHIP	0	5%	1/16W
R442	1-216-829-11	METAL CHIP	4.7K	5%	1/16W
R443	1-216-825-11	METAL CHIP	2.2K	5%	1/16W
R501	1-216-847-11	METAL CHIP	150K	5%	1/16W
R502	1-216-833-11	METAL CHIP	10K	5%	1/16W
R503	1-216-833-11	METAL CHIP	10K	5%	1/16W
R504	1-216-833-11	METAL CHIP	10K	5%	1/16W
R505	1-216-833-11	METAL CHIP	10K	5%	1/16W
R506	1-216-833-11	METAL CHIP	10K	5%	1/16W
R507	1-216-833-11	METAL CHIP	10K	5%	1/16W
R508	1-216-833-11	METAL CHIP	10K	5%	1/16W
R509	1-216-833-11	METAL CHIP	10K	5%	1/16W
R510	1-216-848-11	METAL CHIP	180K	5%	1/16W
R511	1-216-857-11	METAL CHIP	1M	5%	1/16W
R512	1-218-448-11	METAL GLAZE	430K	5%	1/16W
R513	1-216-857-11	METAL CHIP	1M	5%	1/16W
R514	1-216-838-11	METAL CHIP	27K	5%	1/16W
R515	1-216-848-11	METAL CHIP	180K	5%	1/16W
R516	1-216-844-11	METAL CHIP	82K	5%	1/16W
R517	1-216-845-11	METAL CHIP	100K	5%	1/16W
R518	1-216-830-11	METAL CHIP	5.6K	5%	1/16W
R519	1-216-825-11	METAL CHIP	2.2K	5%	1/16W
R520	1-216-857-11	METAL CHIP	1M	5%	1/16W
R521	1-216-838-11	METAL CHIP	27K	5%	1/16W
R522	1-216-838-11	METAL CHIP	27K	5%	1/16W
R523	1-216-838-11	METAL CHIP	27K	5%	1/16W
R524	1-216-838-11	METAL CHIP	27K	5%	1/16W
R525	1-216-838-11	METAL CHIP	27K	5%	1/16W
R526	1-216-844-11	METAL CHIP	82K	5%	1/16W
R527	1-216-838-11	METAL CHIP	27K	5%	1/16W
R528	1-216-844-11	METAL CHIP	82K	5%	1/16W
R529	1-216-838-11	METAL CHIP	27K	5%	1/16W
R530	1-216-849-11	METAL CHIP	220K	5%	1/16W
R533	1-216-815-11	METAL CHIP	330	5%	1/16W
R534	1-216-845-11	METAL CHIP	100K	5%	1/16W
R536	1-216-001-00	METAL CHIP	10	5%	1/10W
R538	1-216-826-11	METAL CHIP	2.7K	5%	1/16W
R539	1-216-826-11	METAL CHIP	2.7K	5%	1/16W
R540	1-216-827-11	METAL CHIP	3.3K	5%	1/16W
R541	1-216-832-11	METAL CHIP	8.2K	5%	1/16W
R542	1-216-832-11	METAL CHIP	8.2K	5%	1/16W
R543	1-216-832-11	METAL CHIP	8.2K	5%	1/16W
R544	1-216-832-11	METAL CHIP	8.2K	5%	1/16W
R545	1-218-287-11	METAL GLAZE	200	5%	1/16W
R546	1-216-821-11	METAL CHIP	1K	5%	1/16W

MAIN

Ref. No.	Part No.	Description	Remark		
R547	1-216-825-11	METAL CHIP	2. 2K	5%	1/16W
R548	1-216-841-11	METAL CHIP	47K	5%	1/16W
R549	1-216-825-11	METAL CHIP	2. 2K	5%	1/16W
R550	1-216-841-11	METAL CHIP	47K	5%	1/16W
R551	1-216-857-11	METAL CHIP	1M	5%	1/16W
R552	1-216-864-11	METAL CHIP	0	5%	1/16W
R553	1-216-832-11	METAL CHIP	8. 2K	5%	1/16W
R554	1-216-839-11	METAL CHIP	33K	5%	1/16W
R556	1-216-833-11	METAL CHIP	10K	5%	1/16W
R558	1-216-835-11	METAL CHIP	15K	5%	1/16W
R559	1-216-845-11	METAL CHIP	100K	5%	1/16W
R561	1-216-845-11	METAL CHIP	100K	5%	1/16W
R562	1-216-845-11	METAL CHIP	100K	5%	1/16W
R563	1-216-837-11	METAL CHIP	22K	5%	1/16W
R564	1-216-825-11	METAL CHIP	2. 2K	5%	1/16W
R565	1-216-824-11	METAL CHIP	1. 8K	5%	1/16W
R566	1-216-839-11	METAL CHIP	33K	5%	1/16W
R567	1-216-854-11	METAL CHIP	560K	5%	1/16W
R568	1-216-845-11	METAL CHIP	100K	5%	1/16W
R569	1-216-821-11	METAL CHIP	1K	5%	1/16W
R570	1-216-843-11	METAL CHIP	68K	5%	1/16W
R571	1-216-864-11	METAL CHIP	0	5%	1/16W
R572	1-216-837-11	METAL CHIP	22K	5%	1/16W
R573	1-216-837-11	METAL CHIP	22K	5%	1/16W
R574	1-216-848-11	METAL CHIP	180K	5%	1/16W
R575	1-216-827-11	METAL CHIP	3. 3K	5%	1/16W
R577	1-216-857-11	METAL CHIP	1M	5%	1/16W
R578	1-218-740-11	METAL CHIP	100	0. 5%	1/16W
R579	1-216-795-11	METAL CHIP	6. 8K	0. 5%	1/16W
R581	1-216-817-11	METAL CHIP	470	5%	1/16W
R582	1-216-850-11	METAL CHIP	270K	5%	1/16W
R583	1-216-833-11	METAL CHIP	10K	5%	1/16W
R584	1-216-829-11	METAL CHIP	4. 7K	5%	1/16W
R585	1-216-857-11	METAL CHIP	1M	5%	1/16W
R586	1-218-732-11	METAL CHIP	47K	0. 50%	1/16W
R587	1-218-732-11	METAL CHIP	47K	0. 50%	1/16W
R588	1-216-833-11	METAL CHIP	10K	5%	1/16W
R589	1-216-820-11	METAL CHIP	820	5%	1/16W
R592	1-216-845-11	METAL CHIP	100K	5%	1/16W
R593	1-216-845-11	METAL CHIP	100K	5%	1/16W
R594	1-216-845-11	METAL CHIP	100K	5%	1/16W
R595	1-216-841-11	METAL CHIP	47K	5%	1/16W
R596	1-216-864-11	METAL CHIP	0	5%	1/16W
R597	1-216-833-11	METAL CHIP	10K	5%	1/16W
R598	1-216-864-11	METAL CHIP	0	5%	1/16W
R599	1-216-827-11	METAL CHIP	3. 3K	5%	1/16W
R613	1-216-833-11	METAL CHIP	10K	5%	1/16W
R614	1-216-827-11	METAL CHIP	3. 3K	5%	1/16W
R615	1-216-833-11	METAL CHIP	10K	5%	1/16W

Ref. No.	Part No.	Description	Remark		
R616	1-218-331-11	METAL GLAZE	51K	5%	1/16W
R617	1-216-821-11	METAL CHIP	1K	5%	1/16W
R623	1-216-833-11	METAL CHIP	10K	5%	1/16W
R624	1-216-833-11	METAL CHIP	10K	5%	1/16W
R625	1-216-845-11	METAL CHIP	100K	5%	1/16W
R626	1-216-821-11	METAL CHIP	1K	5%	1/16W
R627	1-216-821-11	METAL CHIP	1K	5%	1/16W
R629	1-216-830-11	METAL CHIP	5. 6K	5%	1/16W
R630	1-216-821-11	METAL CHIP	1K	5%	1/16W
R631	1-216-821-11	METAL CHIP	1K	5%	1/16W
R633	1-216-813-11	METAL CHIP	220	5%	1/16W
R634	1-216-841-11	METAL CHIP	47K	5%	1/16W
R640	1-216-864-11	METAL CHIP	0	5%	1/16W
R641	1-216-864-11	METAL CHIP	0	5%	1/16W
R642	1-216-864-11	METAL CHIP	0	5%	1/16W
R643	1-216-864-11	METAL CHIP	0	5%	1/16W
R644	1-216-864-11	METAL CHIP	0	5%	1/16W
R645	1-216-864-11	METAL CHIP	0	5%	1/16W
R646	1-216-864-11	METAL CHIP	0	5%	1/16W
R647	1-216-864-11	METAL CHIP	0	5%	1/16W
R648	1-216-864-11	METAL CHIP	0	5%	1/16W
R649	1-216-864-11	METAL CHIP	0	5%	1/16W
R650	1-216-864-11	METAL CHIP	0	5%	1/16W
R651	1-216-864-11	METAL CHIP	0	5%	1/16W
R652	1-216-864-11	METAL CHIP	0	5%	1/16W
R653	1-216-864-11	METAL CHIP	0	5%	1/16W
R657	1-216-821-11	METAL CHIP	1K	5%	1/16W
R660	1-216-864-11	METAL CHIP	0	5%	1/16W
R662	1-216-864-11	METAL CHIP	0	5%	1/16W
R663	1-216-864-11	METAL CHIP	0	5%	1/16W
R665	1-216-864-11	METAL CHIP	0	5%	1/16W
R669	1-218-698-11	METAL CHIP	1. 8K	0. 5%	1/16W
R670	1-216-864-11	METAL CHIP	0	5%	1/16W
R671	1-216-809-11	METAL CHIP	100	5%	1/16W
R802	1-216-821-11	METAL CHIP	1K	5%	1/16W
R803	1-216-821-11	METAL CHIP	1K	5%	1/16W
R811	1-216-814-11	METAL CHIP	270	5%	1/16W
R812	1-218-676-11	METAL CHIP	220	0. 50%	1/16W
R814	1-216-857-11	METAL CHIP	1M	5%	1/16W
R816	1-216-845-11	METAL CHIP	100K	5%	1/16W
R820	1-216-829-11	METAL CHIP	4. 7K	5%	1/16W
R821	1-216-821-11	METAL CHIP	1K	5%	1/16W
R824	1-216-833-11	METAL CHIP	10K	5%	1/16W
R825	1-216-829-11	METAL CHIP	4. 7K	5%	1/16W
R826	1-216-833-11	METAL CHIP	10K	5%	1/16W
R828	1-218-675-11	METAL CHIP	200	0. 50%	1/16W
R829	1-216-864-11	METAL CHIP	0	5%	1/16W
R833	1-218-708-11	METAL CHIP	4. 7K	0. 50%	1/16W
R834	1-218-708-11	METAL CHIP	4. 7K	0. 50%	1/16W

Ref. No.	Part No.	Description	Remark		
R835	1-216-864-11	METAL CHIP	0	5%	1/16W
R836	1-216-841-11	METAL CHIP	47K	5%	1/16W
R837	1-216-841-11	METAL CHIP	47K	5%	1/16W
R839	1-216-841-11	METAL CHIP	47K	5%	1/16W
R840	1-216-841-11	METAL CHIP	47K	5%	1/16W
R841	1-216-841-11	METAL CHIP	47K	5%	1/16W
R842	1-218-708-11	METAL CHIP	4.7K	0.50%	1/16W
R845	1-216-841-11	METAL CHIP	47K	5%	1/16W
R848	1-216-841-11	METAL CHIP	47K	5%	1/16W
R849	1-216-841-11	METAL CHIP	47K	5%	1/16W
R850	1-216-841-11	METAL CHIP	47K	5%	1/16W
R851	1-216-841-11	METAL CHIP	47K	5%	1/16W
R852	1-216-841-11	METAL CHIP	47K	5%	1/16W
R870	1-216-864-11	METAL CHIP	0	5%	1/16W
R871	1-216-864-11	METAL CHIP	0	5%	1/16W
R873	1-216-864-11	METAL CHIP	0	5%	1/16W
R874	1-216-821-11	METAL CHIP	1K	5%	1/16W
R875	1-216-864-11	METAL CHIP	0	5%	1/16W
R876	1-216-864-11	METAL CHIP	0	5%	1/16W
R877	1-216-864-11	METAL CHIP	0	5%	1/16W
R878	1-216-864-11	METAL CHIP	0	5%	1/16W
R879	1-216-864-11	METAL CHIP	0	5%	1/16W
R880	1-216-864-11	METAL CHIP	0	5%	1/16W
R881	1-216-864-11	METAL CHIP	0	5%	1/16W
R882	1-216-864-11	METAL CHIP	0	5%	1/16W
R883	1-216-864-11	METAL CHIP	0	5%	1/16W
R884	1-216-864-11	METAL CHIP	0	5%	1/16W
R885	1-216-864-11	METAL CHIP	0	5%	1/16W
R886	1-216-864-11	METAL CHIP	0	5%	1/16W
R887	1-216-864-11	METAL CHIP	0	5%	1/16W
R888	1-216-864-11	METAL CHIP	0	5%	1/16W
R889	1-216-864-11	METAL CHIP	0	5%	1/16W
R890	1-216-864-11	METAL CHIP	0	5%	1/16W
R891	1-216-851-11	METAL CHIP	330K	5%	1/16W
R892	1-216-864-11	METAL CHIP	0	5%	1/16W
R893	1-216-864-11	METAL CHIP	0	5%	1/16W
R894	1-216-845-11	METAL CHIP	100K	5%	1/16W
R896	1-216-845-11	METAL CHIP	100K	5%	1/16W
R897	1-216-853-11	METAL CHIP	470K	5%	1/16W
R898	1-216-851-11	METAL CHIP	330K	5%	1/16W
R899	1-216-809-11	METAL CHIP	100	5%	1/16W
R5000	1-216-820-11	METAL CHIP	820	5%	1/16W
R5001	1-216-864-11	METAL CHIP	0	5%	1/16W
R5002	1-216-850-11	METAL CHIP	270K	5%	1/16W
R5003	1-216-864-11	METAL CHIP	0	5%	1/16W
R5005	1-216-851-11	METAL CHIP	330K	5%	1/16W
R5006	1-216-838-11	METAL CHIP	27K	5%	1/16W
R5007	1-216-851-11	METAL CHIP	330K	5%	1/16W
R5008	1-218-745-11	METAL CHIP	160K	0.50%	1/16W

Ref. No.	Part No.	Description	Remark		
R5011	1-216-833-11	METAL CHIP	10K	5%	1/16W
R5014	1-216-829-11	METAL CHIP	4.7K	5%	1/16W
R5015	1-216-839-11	METAL CHIP	33K	5%	1/16W
R5016	1-216-839-11	METAL CHIP	33K	5%	1/16W
R5017	1-216-843-11	METAL CHIP	68K	5%	1/16W
R5018	1-216-843-11	METAL CHIP	68K	5%	1/16W
R5020	1-216-857-11	METAL CHIP	1M	5%	1/16W
R5021	1-216-849-11	METAL CHIP	220K	5%	1/16W
R5022	1-216-835-11	METAL CHIP	15K	5%	1/16W
R5023	1-216-864-11	METAL CHIP	0	5%	1/16W
R5024	1-216-864-11	METAL CHIP	0	5%	1/16W
R5025	1-216-859-11	METAL GLAZE	1.5M	5%	1/16W
R5026	1-216-826-11	METAL CHIP	2.7K	5%	1/16W
R5027	1-216-832-11	METAL CHIP	8.2K	5%	1/16W
R5028	1-216-826-11	METAL CHIP	4.7K	5%	1/16W
R5029	1-216-864-11	METAL CHIP	0	5%	1/16W
R5030	1-216-864-11	METAL CHIP	0	5%	1/16W
R5031	1-216-839-11	METAL CHIP	33K	5%	1/16W
R5032	1-216-843-11	METAL CHIP	68K	5%	1/16W
R5033	1-216-864-11	METAL CHIP	0	5%	1/16W
R5034	1-216-857-11	METAL CHIP	1M	5%	1/16W
R5043	1-216-864-11	METAL CHIP	0	5%	1/16W
R5044	1-216-864-11	METAL CHIP	0	5%	1/16W
R5045	1-216-864-11	METAL CHIP	0	5%	1/16W
R5046	1-216-864-11	METAL CHIP	0	5%	1/16W
R5047	1-216-864-11	METAL CHIP	0	5%	1/16W
R5048	1-216-864-11	METAL CHIP	0	5%	1/16W
R5049	1-216-864-11	METAL CHIP	0	5%	1/16W
R5050	1-216-864-11	METAL CHIP	0	5%	1/16W
R5051	1-216-864-11	METAL CHIP	0	5%	1/16W
R5052	1-216-864-11	METAL CHIP	0	5%	1/16W
R5053	1-216-864-11	METAL CHIP	0	5%	1/16W
R5054	1-216-864-11	METAL CHIP	0	5%	1/16W
R5055	1-216-830-11	METAL CHIP	5.6K	5%	1/16W
R5056	1-216-864-11	METAL CHIP	0	5%	1/16W
R5058	1-216-825-11	METAL CHIP	2.2K	5%	1/16W
R5059	1-216-845-11	METAL CHIP	100K	5%	1/16W
R5060	1-216-865-11	METAL CHIP	3K	5%	1/16W
R5061	1-216-833-11	METAL CHIP	10K	5%	1/16W
R5062	1-216-833-11	METAL CHIP	10K	5%	1/16W
R5063	1-216-857-11	METAL CHIP	1M	5%	1/16W
R5065	1-216-836-11	METAL CHIP	18K	5%	1/16W
R5066	1-216-839-11	METAL CHIP	33K	5%	1/16W
R5067	1-216-839-11	METAL CHIP	33K	5%	1/16W
R5068	1-216-864-11	METAL CHIP	0	5%	1/16W
R5069	1-216-864-11	METAL CHIP	0	5%	1/16W
R5070	1-216-833-11	METAL CHIP	10K	5%	1/16W
R5071	1-216-833-11	METAL CHIP	10K	5%	1/16W
R5072	1-216-833-11	METAL CHIP	10K	5%	1/16W

MAIN

PTOC

Ref. No.	Part No.	Description	Remark		
R5073	1-216-849-11	METAL CHIP	220K	5%	1/16W
R5074	1-216-849-11	METAL CHIP	220K	5%	1/16W
R5075	1-216-845-11	METAL CHIP	100K	5%	1/16W
R5076	1-216-853-11	METAL CHIP	470K	5%	1/16W
R5077	1-216-853-11	METAL CHIP	470K	5%	1/16W
R5078	1-216-853-11	METAL CHIP	470K	5%	1/16W
R5079	1-216-837-11	METAL CHIP	22K	5%	1/16W
R5080	1-218-330-11	METAL GLAZE	11K	5%	1/16W
R5081	1-216-837-11	METAL CHIP	22K	5%	1/16W
R5082	1-216-001-00	METAL CHIP	10	5%	1/10W
R5086	1-216-864-11	METAL CHIP	0	5%	1/16W
R5087	1-216-864-11	METAL CHIP	0	5%	1/16W
R5093	1-216-860-11	METAL GLAZE	1.8M	5%	1/16W
R5096	1-216-833-11	METAL CHIP	10K	5%	1/16W
R5097	1-216-833-11	METAL CHIP	10K	5%	1/16W
R5105	1-216-835-11	METAL CHIP	15K	5%	1/16W
R5106	1-216-864-11	METAL CHIP	0	5%	1/16W
R5108	1-216-821-11	METAL CHIP	1K	5%	1/16W
R5109	1-216-864-11	METAL CHIP	0	5%	1/16W
R5110	1-216-835-11	METAL CHIP	15K	5%	1/16W
R5117	1-216-834-11	METAL CHIP	12K	5%	1/16W
R5118	1-216-864-11	METAL CHIP	0	5%	1/16W
R5200	1-216-864-11	METAL CHIP	0	5%	1/16W
R5201	1-216-809-11	METAL CHIP	100	5%	1/16W
R5202	1-216-821-11	METAL CHIP	1K	5%	1/16W
R5203	1-216-864-11	METAL CHIP	0	5%	1/16W
R5205	1-216-833-11	METAL CHIP	10K	5%	1/16W
R5206	1-216-295-00	METAL CHIP	0	5%	1/10W
R5207	1-216-295-00	METAL CHIP	0	5%	1/10W
R5208	1-216-829-11	METAL CHIP	4.7K	5%	1/16W
R5209	1-216-845-11	METAL CHIP	100K	5%	1/16W
R5210	1-216-845-11	METAL CHIP	100K	5%	1/16W
R5212	1-216-849-11	METAL CHIP	220K	5%	1/16W
R5216	1-216-864-11	METAL CHIP	0	5%	1/16W
R5217	1-216-864-11	METAL CHIP	0	5%	1/16W
R5218	1-216-864-11	METAL CHIP	0	5%	1/16W
R5219	1-216-849-11	METAL CHIP	220K	5%	1/16W
R5220	1-218-708-11	METAL CHIP	4.7K	0.50%	1/16W
R5222	1-216-850-11	METAL CHIP	270K	5%	1/16W
R8004	1-216-841-11	METAL CHIP	47K	5%	1/16W
R8006	1-216-853-11	METAL CHIP	470K	5%	1/16W
R8007	1-216-821-11	METAL CHIP	1K	5%	1/16W
R8008	1-216-819-11	METAL CHIP	680	5%	1/16W
R8009	1-216-845-11	METAL CHIP	100K	5%	1/16W
R8041	1-216-841-11	METAL CHIP	47K	5%	1/16W
R8042	1-216-841-11	METAL CHIP	47K	5%	1/16W
R8043	1-216-864-11	METAL CHIP	0	5%	1/16W

Ref. No.	Part No.	Description	Remark		
< VARIABLE RESISTOR >					
RV302	1-223-172-21	RES, VAR, CARBON 10K/10K (VOLUME)			
RV501	1-238-089-11	RES, ADJ, CERMET	4.7K		
RV502	1-238-091-11	RES, ADJ, CERMET	22K		
RV503	1-238-090-11	RES, ADJ, CERMET	10K		
RV504	1-238-090-11	RES, ADJ, CERMET	10K		
RV505	1-223-270-21	RES, ADJ	100		
RV507	1-238-091-11	RES, ADJ, CERMET	22K		
RV508	1-238-091-11	RES, ADJ, CERMET	22K		
RV510	1-238-089-11	RES, ADJ, CERMET	4.7K		
RV511	1-238-089-11	RES, ADJ, CERMET	4.7K		
RV512	1-238-089-11	RES, ADJ, CERMET	4.7K		
RV513	1-238-089-11	RES, ADJ, CERMET	4.7K		
RV514	1-238-091-11	RES, ADJ, CERMET	22K		
RV515	1-238-091-11	RES, ADJ, CERMET	22K		
RV516	1-238-092-11	RES, ADJ, CERMET	47K		
RV517	1-238-092-11	RES, ADJ, CERMET	47K		
RV518	1-238-088-11	RES, ADJ, CERMET	2.2K		
RV519	1-238-088-11	RES, ADJ, CERMET	2.2K		
< SWITCH >					
S801	1-572-467-31	SWITCH, PUSH (1 KEY) (EDIT)			
< THERMISTOR >					
TH501	1-809-986-21	THERMISTOR NTH5G36B103K02TE			
< VIBRATOR >					
X601	1-579-725-21	VIBRATOR, CRYSTAL (22MHz)			
X602	1-579-847-21	OSCILLATOR, CRYSTAL (55MHz)			
X801	1-579-709-11	VIBRATOR, CRYSTAL (32KHz)			
X802	1-579-846-21	VIBRATOR, CERAMIC (12MHz)			

*	1-648-595-12	PTOC BOARD			

< CAPACITOR >					
C691	1-135-264-21	TANTALUM CHIP	22uF	20%	10V
C692	1-135-181-21	TANTALUM CHIP	4.7uF	20%	6.3V
C693	1-135-181-21	TANTALUM CHIP	4.7uF	20%	6.3V
< DIODE >					
D691	8-719-941-09	DIODE DAP202U			
D692	8-719-404-46	DIODE MA110			
D693	8-719-404-46	DIODE MA110			
< IC >					
IC691	8-759-035-90	IC SC7S02F			

<u>Ref. No.</u>	<u>Part No.</u>	<u>Description</u>				<u>Remark</u>
IC692	8-759-082-57	IC TC7W04FU				
< REGISTOR >						
R691	1-216-849-11	METAL CHIP	220K	5%	1/16W	
R692	1-216-849-11	METAL CHIP	220K	5%	1/16W	
R693	1-216-833-11	METAL CHIP	10K	5%	1/16W	
R694	1-216-845-11	METAL CHIP	100K	5%	1/16W	

