

MDS-PC3

SERVICE MANUAL

Self Diagnostics
Supported model



*US Model
Canadian Model
AEP Model
UK Model
E Model*

Photo: SILVER

US and foreign patents licensed from Dolby Laboratories Licensing Corporation.

Model Name Using Similar Mechanism	MDS-JE640
MD Mechanism Type	MDM-7A
Optical Pick-up Type	KMS-260B/J1N

SPECIFICATIONS

System	MiniDisc digital audio system
Disc	MiniDisc
Laser	Semiconductor laser ($\lambda = 780 \text{ nm}$) Emission duration: continuous Less than $44.6 \mu\text{W}^*$
Laser output	* This output is the value measured at a distance of 200 mm from the objective lens surface on the Optical Pick-up Block with 7 mm aperture.
Laser diode	Material: GaAlAs
Revolutions (CLV)	400 rpm to 900 rpm
Error correction	Advanced Cross Interleave Reed Solomon Code (ACIRC)
Sampling frequency	44.1 kHz
Coding	Adaptive Transform Acoustic Coding (ATRAC)
Modulation system	EFM (Eight-to-Fourteen Modulation)
Number of channels	2 stereo channels
Frequency response	5 to 20,000 Hz $\pm 0.5 \text{ dB}$
Signal-to-noise ratio	Over 94 dB during playback
Wow and flutter	Below measurable limit

Inputs

LINE (ANALOG) IN	Jack type: stereo-mini Impedance: 47 kilohms Rated input: 500 mVrms Minimum input: 125 mVrms
DIGITAL (OPTICAL) IN	Connector type: square optical Impedance: 660 nm (optical wave length)

Outputs

LINE (ANALOG) OUT (VARIABLE)	Jack type: stereo-mini Rated output: 1 Vrms (at 50 kilohms) Load impedance: Over 10 kilohms
DIGITAL (OPTICAL) OUT	Connector type: square optical Rated output: -18 dBm Impedance: 660 nm (optical wave length)
PHONES	Jack type: stereo-mini Rated output: 5 mW Load impedance: 32 ohms

General

Where purchased	Power requirements*
U.S.A. and Canada	120 V AC, 60 Hz
Other countries	220 - 230 V AC, 50/60 Hz

* Using an AC power adaptor (supplied)

Power consumption	7 W
Dimensions (approx.)	152 x 52 x 255 mm ($6 \times 2 \frac{1}{8} \times 10 \frac{1}{8}$ inches) (w/h/d) incl. projecting parts and controls
Mass (approx.)	1.0 kg (2 lb 4 oz)

Supplied accessories



- AC power adaptor (1)
 - Audio connecting cord (stereo mini-plug $\times 1 \leftrightarrow$ stereo mini-plug $\times 1$) (1)
 - Optical cable (1)
 - Remote commander (remote) RM-D52M (1)
 - PC connecting kit PCLK-MN10* (1)
- * Required for operation by personal computer. For details, refer to the operating instructions supplied with the PCLK-MN10.







MINIDISC DECK

SONY[®]

***Note:**

As this unit has only a few buttons, one button is assigned with several functions in the test mode.”

Press the  button,  knob to switch the functions.







- Each time the  button is pressed, the display switches in the following order, “PGM” → “blank” → “PGM” → —.
- Rotate the  knob and the display switches in the following order, “blank” → “TOC” → “EDIT” → “TOC EDIT” → “” → “” → “” → “” → “blank” → —.

For simplicity, operations of  button will not be described here.

Example) : Lights-out “PGM” and press the  button.
 “PGM”: Display “PGM” and press the  button.

The functions of each button change with the display.

Buttons and Corresponding Functions

Buttons	“PGM” displayed	“PGM” Lights-out							
		LCD displayed							
		Nothing displayed	TOC	EDIT	TOC EDIT				
		ENTER (YES)	REPEAT	PLAY	CLEAR	FF	PLAY MODE	DISPLAY	—
	EJECT	MENU (EDIT)/ NO	STOP	REC	—	FR	SCROLL	TIME	—

SELF-DIAGNOSIS FUNCTION

The self-diagnosis function consists of error codes for customers which are displayed automatically when errors occur, and error codes which show the error history in the test mode during servicing. For details on how to view error codes for the customer, refer to the following box in the instruction manual. For details on how to check error codes during servicing, refer to the following “Procedure for using the Self-Diagnosis Function (Error History Display Mode)”.

Self-Diagnosis Function

The deck’s self-diagnosis function automatically checks the condition of the MD deck when an error occurs, then issues a three-digit code and an error message on the display. If the code and message alternate, find them in the following table and perform the indicated countermeasure. Should the problem persist, consult your nearest Sony dealer.

Three-digit code/Message	Cause/Remedy
C11/Protected	The inserted MD is record-protected. ➔ Take out the MD and close the record-protect slot (page 13).
C12/Cannot Copy	An attempt was made to play a disc that is not compatible with this deck (MD data disc, etc.). ➔ Replace the disc.
C13/Rec Error	The recording was not made properly. ➔ Set the deck in a stable surface, and repeat the recording procedure. The inserted MD is dirty (with smudges, fingerprints, etc.), scratched, or substandard in quality. ➔ Replace the disc and repeat the recording procedure.
C13/Read Error	The deck could not read the TOC on the MD properly. ➔ Take out the MD and insert it again.
C14/ToC Error	The deck could not read the TOC on the MD properly. ➔ Insert another disc. ➔ If possible, erase all the tracks on the MD (page 29).
C41/Cannot Copy	The digitally dubbed material cannot be recorded digitally (page 11).
C71/Din Unlock	The sporadic appearance of this message is caused by the digital signal being recorded. This will not affect the recording. While recording from a digital component connected through the DIGITAL (OPTICAL) IN connector, the digital connecting cable was unplugged or the digital component turned off. ➔ Connect the cable or turn the digital component back on.
E0001/MEMORY NG	There is an error in the internal data that the deck needs in order to operate. ➔ Consult your nearest Sony dealer.
E0101/LASER NG	There is a problem with the optical pickup. ➔ Consult your nearest Sony dealer.

Procedure for using the Self-Diagnosis Function (Error History Display Mode).

Note: Perform the self-diagnosis function in the “error history display mode” in the test mode. The following describes the least required procedure. Be careful not to enter other modes by mistake. If you set other modes accidentally, press the  button to exit the mode.

1. While pressing the **[AMS]** knob and **[■/▲]** button, connect the power plug to the outlet, and release the **[AMS]** knob and **[■/▲]** button. When the test mode is set, “[Check]” will be displayed.
2. Rotate the **[AMS]** knob and when “[Service]” is displayed, press the **[I/⏻]** button.
3. Rotate the **[AMS]** knob and display “Err Display”.
4. Pressing the **[I/⏻]** button sets the error history mode and displays “op rec tm”.
5. Select the contents to be displayed or executed using the **[AMS]** knob.
6. Pressing the **[AMS]** knob will display or execute the contents selected.
7. Pressing the **[AMS]** knob another time returns to step 4.
8. Pressing the **[■/▲]** button displays “Err Display” and exits the error history mode.
9. To exit the test mode, remove the power plug to the outlet.

ITEMS OF ERROR HISTORY MODE ITEMS AND CONTENTS

Selecting the Test Mode

Display	History
op rec tm	Displays the total recording time. When the total recording time is more than 1 minute, displays the hour and minute When less than 1 minute, displays “Under 1 min” The display time is the time the laser is set to high power, which is about 1/4 of the actual recording time.
op play tm	Displays the total playback time. When the total playback time is more than 1 minute, displays the hour and minute When less than 1 minute, displays “Under 1 min”
spdl rp tm	Displays the total rotating time of the spindle motor. When the total rotating time is more than 1 minute, displays the hour and minute When less than 1 minute, displays “Under 1 min”
retry err	Displays the total number of retry errors during recording and playback Displays “r xx p yy”. xx is the number of errors during recording. yy is the number of errors during playback. This is displayed in hexadecimal from 00 to FF.
total err	Displays the total number of errors Displays “total xx”. This is displayed in hexadecimal from 00 to FF.
err history	Displays the past ten errors. Displays “0x ErrCd@@”. X is the history number. The younger the number, the more recent is the history (00 is the latest). @@ is the error code. Select the error history number using the [AMS] knob.
retry adrs	Displays the past five retry addresses. Displays “xx ADRS yyyy”, xx is the history number, yyyy is the cluster with the retry error. Select the error history number using the [AMS] knob.
er refresh	Mode for erasing the error and retry address histories Procedure 1. Press the [AMS] knob when displayed as “er refresh”. 2. Press the [I/⏻] button when the display changes to “er refresh?”. When “complete!” is displayed, it means erasure has completed. Be sure to check the following after executing this mode. *Data has been erased. *Perform recording and playback, and check that the mechanism is normal.
tm refresh	Mode for erasing the total time of recording and playback Procedure 1. Press the [AMS] knob when displayed as “tm refresh”. 2. Press the [I/⏻] button when the display changes to “tm refresh?”. When “complete!” is displayed, it means erasure has completed.
op change	Mode for erasing the total time of op rec tm, op play tm. These histories are based on the time of replacement of the optical pickup. If the optical pick-up has been replaced, perform this procedure and erase the history. Procedure 1. Press the [AMS] knob when displayed as “op change”. 2. Press the [I/⏻] button when the display changes to “op change?”. When “Complete!” is displayed, it means erasure has completed.
spdl change	Mode for erasing the total spdl rp tm time These histories are based on the time of replacement of the spindle motor. If the spindle motor has been replaced, perform this procedure and erase the history. Procedure 1. Press the [AMS] knob when displayed as “spdl change” 2. Press the [I/⏻] button when the display changes to “spdl change?” When “Complete!” is displayed, it means erasure has completed.

Table of Error Codes

Error Code	Description
10	Could not load
12	Loading switches combined incorrectly
20	Timed out without reading the top of PTOC
21	Could read top of PTOC, but detected error
22	Timed out without accessing UTOC
23	Timed out without reading UTOC
24	Error in UTOC
30	Could not start playback
31	Error in sector
40	Retry cause generated during normal recording
41	Retried in DRAM overflow
42	Retry occurred during TOC writing
43	Retry aborted during S.F editing
50	Other than access processing, and could not read address.
51	Focus NG occurred and overran.

TABLE OF CONTENTS

1. SERVICING NOTES	5
2. GENERAL	11
3. DISASSEMBLY	
3-1. Case (U)	14
3-2. MD Mechanism Deck (MDM-74)	14
3-3. Main Board	15
3-4. Over Light Head (HR901), BD (MD) Board	15
3-5. Holder Assy	16
3-6. Loading Motor Assy (M103)	16
3-7. Sled Motor Assy (M102), Slider	17
3-8. Optical Pick-up (MD) (KMS-260B/JIN)	17
3-9. Spindle Motor Assy (M101)	18
4. TEST MODE	19
5. ELECTRICAL ADJUSTMENTS	24
6. DIAGRAMS	
6-1. Block Diagrams	
• BD Section	36
• Main Section	37
6-2. Printed Wiring Board – BD Section –	38
6-3. Schematic Diagram – BD Section (1/2) –	39
6-4. Schematic Diagram – BD Section (2/2) –	40
6-5. Printed Wiring Board – Main Section –	41
6-6. Schematic Diagram – Main Section (1/2) –	42
6-7. Schematic Diagram – Main Section (2/2) –	43
6-8. Printed Wiring Board – Panel Section –	44
6-9. Schematic Diagram – Panel Section –	45
6-10. IC Block Diagrams	46
6-11. IC Pin Functions	49
7. EXPLODED VIEWS	
7-1. Chassis Section	54
7-2. Mechanism Section-1 (MDM-7A)	55
7-3. Mechanism Section-2 (MDM-7A)	56
8. ELECTRICAL PARTS LIST	57

SECTION 1 SERVICE NOTES

NOTES ON HANDLING THE OPTICAL PICK-UP BLOCK OR BASE UNIT

The laser diode in the optical pick-up block may suffer electrostatic break-down because of the potential difference generated by the charged electrostatic load, etc. on clothing and the human body. During repair, pay attention to electrostatic break-down and also use the procedure in the printed matter which is included in the repair parts.

The flexible board is easily damaged and should be handled with care.

NOTES ON LASER DIODE EMISSION CHECK

Never look into the laser diode emission from right above when checking it for adjustment. It is feared that you will lose your sight.

Laser component in this product is capable of emitting radiation exceeding the limit for Class 1.

CLASS 1 LASER PRODUCT
LUOKAN 1 LASERLAITE
KLASS 1 LASERAPPARAT

This appliance is classified as a CLASS 1 LASER product. The CLASS 1 LASER PRODUCT MARKING is located on the rear exterior.

CAUTION : INVISIBLE LASER RADIATION WHEN OPEN AND INTERLOCKS DEFEATED. AVOID EXPOSURE TO BEAM.
ADVARSEL : USYNLIG LASERSTRÅLING VED ÅBNING NÅR SIKKERHEDSAFBRYDERE ER UDE AF FUNKTION. UNDGÅ UDSÆTTELSE FOR STRÅLING.
VORSICHT : UNSICHTBARE LASERSTRÄHLUNG, WENN ABDECKUNG GEÖFFNET UND SICHERHEITSVERRIEGELUNG ÜBERBRÜCKT. NICHT DEM STRAHL AUSSETZEN.
VARO! : AVATTAESSA JA SUOJALUKITUS OHITETTAESSA OLET ALTIINA NÄKYMÄTTÖMÄLLE LASERSÄTELYLLE, ÄLÄ KATSO SÄTEESEEN.
WARNING : OSYNLIG LASERSTRÅLING NÅR DENNA DEL ÄR ÖPPNAD OCH SPÄRREN ÄR URKOPPLAD, BETRAKTA EJ STRÅLEN.
ADVERSEL : USYNLIG LASERSTRÅLING NÅR DEKSEL ÅPNES OG SIKKERHEDSLÅS BRYTES, UNNGÅ EKSPONERING FOR STRÅLEN.
VIGYAZAT! : A BURKOLAT NYITÁSÁKOR LÁTHATATLAN LÉZERSUGÁRVESZÉLY! KERÜLJE A BESUGÁRZÁST!

This caution label is located inside the unit.

CAUTION

Use of controls or adjustments or performance of procedures other than those specified herein may result in hazardous radiation exposure.

Notes on chip component replacement

- Never reuse a disconnected chip component.
- Notice that the minus side of a tantalum capacitor may be damaged by heat.

Flexible Circuit Board Repairing

- Keep the temperature of soldering iron around 270°C during repairing.
- Do not touch the soldering iron on the same conductor of the circuit board (within 3 times).
- Be careful not to apply force on the conductor when soldering or unsoldering.

SAFETY-RELATED COMPONENT WARNING!!

COMPONENTS IDENTIFIED BY MARK \triangle OR DOTTED LINE WITH MARK \triangle ON THE SCHEMATIC DIAGRAMS AND IN THE PARTS LIST ARE CRITICAL TO SAFE OPERATION. REPLACE THESE COMPONENTS WITH SONY PARTS WHOSE PART NUMBERS APPEAR AS SHOWN IN THIS MANUAL OR IN SUPPLEMENTS PUBLISHED BY SONY.

Lead free soldering

MAIN and PANEL boards of this product are lead free soldered (contains no lead).

Lead-free solder have the following characteristics.

- The melting point is about 40 °C higher than conventional solder. Conventional soldering iron can be used, but must be pressed for a longer time. When using the soldering iron with a temperature adjustment function, set to about 350 °C.
- Note:** Pressing the soldering iron too long may cause the board pattern (copper coating) to peel off.

- Strong viscosity
As it has stronger viscosity than conventional solder, make sure the IC terminal does not solder bridge.
- Can be used with conventional solder
Though it is best to add lead-free solder only, conventional solder can also be added.
- Boards using lead-free solder are printed with the LF mark meaning "Lead Free".

SAFETY CHECK-OUT

After correcting the original service problem, perform the following safety check before releasing the set to the customer: Check the antenna terminals, metal trim, "metallized" knobs, screws, and all other exposed metal parts for AC leakage. Check leakage as described below.

LEAKAGE TEST

The AC leakage from any exposed metal part to earth ground and from all exposed metal parts to any exposed metal part having a return to chassis, must not exceed 0.5 mA (500 microamperes). Leakage current can be measured by any one of three methods.

1. A commercial leakage tester, such as the Simpson 229 or RCA WT-540A. Follow the manufacturers' instructions to use these instruments.
2. A battery-operated AC milliammeter. The Data Precision 245 digital multimeter is suitable for this job.
3. Measuring the voltage drop across a resistor by means of a VOM or battery-operated AC voltmeter. The "limit" indication is 0.75 V, so analog meters must have an accurate low-voltage scale. The Simpson 250 and Sanwa SH-63Trd are examples of a passive VOM that is suitable. Nearly all battery operated digital multimeters that have a 2 V AC range are suitable. (See Fig. A)

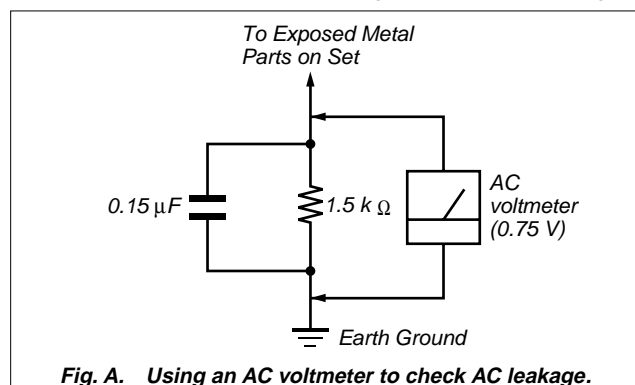

Fig. A. Using an AC voltmeter to check AC leakage.

ATTENTION AU COMPOSANT AYANT RAPPORT À LA SÉCURITÉ!

LES COMPOSANTS IDENTIFÉS PAR UNE MARQUE \triangle SUR LES DIAGRAMMES SCHÉMATIQUES ET LA LISTE DES PIÈCES SONT CRITIQUES POUR LA SÉCURITÉ DE FONCTIONNEMENT. NE REMPLACER CES COMPOSANTS QUE PAR DES PIÈCES SONY DONT LES NUMÉROS SONT DONNÉS DANS CE MANUEL OU DANS LES SUPPLÉMENTS PUBLIÉS PAR SONY.

JIG FOR CHECKING BD BOARD WAVEFORM

The special jig (J-2501-196-A) is useful for checking the waveform of the BD board. The names of terminals and the checking items to be performed are shown as follows.

- GND : Ground
- I+3V : For measuring Iop (Check the deterioration of the optical pick-up laser)
- Iop : For measuring Iop (Check the deterioration of the optical pick-up laser)
- TE : TRK error signal (Traverse adjustment)
- VC : Reference level for checking the signal
- RF : RF signal (Check jitter)
- FE : Focus error signal

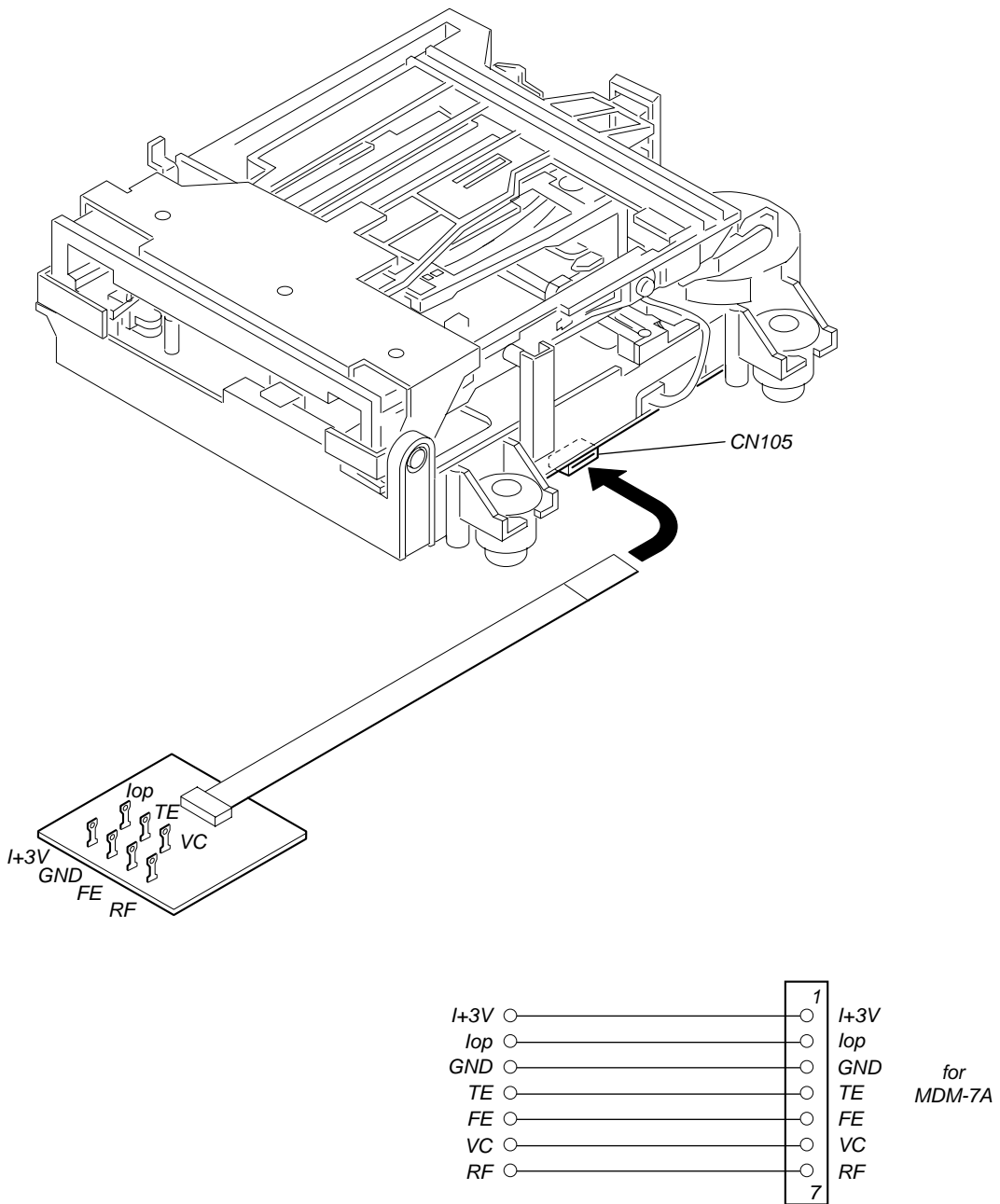

Iop DATA RECORDING AND DISPLAY WHEN OPTICAL PICK-UP AND NON-VOLATILE MEMORY (IC195 OF BD BOARD) ARE REPLACED

The Iop value labeled on the optical pick-up can be recorded in the non-volatile memory. By recording the value, it will eliminate the need to look at the value on the label of the optical pick-up. When replacing the optical pick-up or non-volatile memory (IC195 of BD board), record the Iop value on the optical pick-up according to the following procedure.

Record Procedure:

1. While pressing the **AMS** knob and **■/▲** button, connect the power plug to the outlet, and release the **AMS** knob and **■/▲** button.
2. Rotate the **AMS** knob to display “[Service]”, and press the **I/⏻** button.
3. Rotate the **AMS** knob to display “Iop Write” (C05), and press the **I/⏻** button.
4. The display becomes “Ref=@@.@” (@ is an arbitrary number) and the numbers which can be changed will blink.
5. Input the Iop value written on the optical pick-up.
To select the number : Rotate the **AMS** knob.
To select the digit : Press the **AMS** knob.
6. When the **I/⏻** button is pressed, the display becomes “Measu=@@.@” (@ is an arbitrary number).
7. As the adjustment results are recorded for the 6 value. Leave it as it is and press the **I/⏻** button.
8. “Complete! !” will be displayed momentarily. The value will be recorded in the non-volatile memory and the display will become “Iop Write” (C05).
9. Press the **■/▲** button to complete, remove the power plug to the outlet.

Display Procedure:

1. While pressing the **AMS** knob and **■/▲** button, connect the power plug to the outlet, and release the **AMS** knob and **■/▲** button.
2. Rotate the **AMS** knob to display “[Service]”, and press the **I/⏻** button.
3. Rotate the **AMS** knob to display “Iop Read” (C26), and press the **I/⏻** button.
4. “@@.@/###.#” is displayed and the recorded contents are displayed.
@@.@ : indicates the Iop value labeled on the pick-up.
###.# : indicates the Iop value after adjustment
5. To end, press the **AMS** button or **■/▲** button to display “Iop Read” (C26), remove the power plug to the outlet.

CHECKS PRIOR TO PARTS REPLACEMENT AND ADJUSTMENTS

Before performing repairs, perform the following checks to determine the faulty locations up to a certain extent. Details of the procedures are described in “5 Electrical Adjustments”.

- 5-6-2. Laser power check (see page 27)
- 5-6-3. Iop Compare (see page 27)
- 5-6-4. Auto Check (see page 28)

Note:

The criteria for determination above is intended merely to determine if satisfactory or not, and does not serve as the specified value for adjustments.

When performing adjustments, use the specified values for adjustments.

FORCED RESET

The system microprocessor can be reset in the following procedure.

Use these procedure when the unit cannot be operated normally due to the overrunning of the microprocessor, etc.

Procedure :

Remove the short-pin attached to CN420, and then attach it again.

[MAIN BOARD] (Component Side)

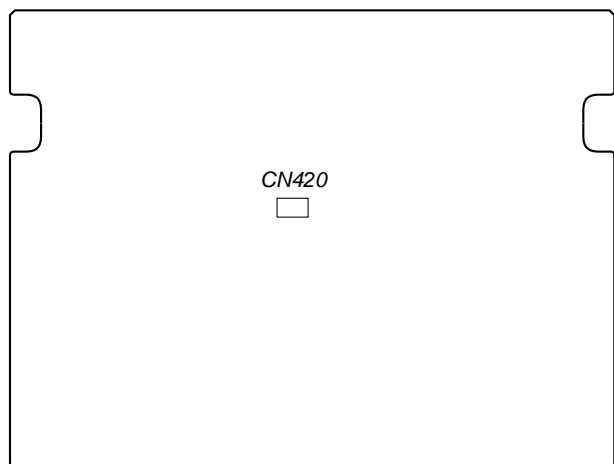

RETRY CAUSE DISPLAY MODE

- In this test mode, the causes for retry of the unit during recording can be displayed on the indication vessel. During playback, the “track mode” for obtaining track information will be set. This is useful for locating the faulty part of the unit.
- The following will be displayed :
 During recording and stop : Retry cause, number of retries, and number of retry errors.
 During playback : Information such as type of disc played, part played, copyright.
 These are displayed in hexadecimal.

Procedure:

1. Press the button, button and button continuously for about 10 seconds.
2. Rotate the knob to display “Debug Disp”, Then press the button.
3. When the mode is set, “RTs 00c 00e 00” is displayed.
4. Press the button to start recording. Then press the button and start recording.
5. To check the “track mode”, press the button to start play.
6. To exit the test mode, press the button, and turn OFF the power.
 If the test mode cannot be exited, refer to “Forced Reset” on page 8.

Fig. 1 Reading the Test Mode Display (During recording and stop)

Indication vessel display

- @@ : Cause of retry
- ## : Number of retries
- ** : Number of retry errors

Fig. 2 Reading the Test Mode Display (During playback)

Indication vessel display

- @@ : Parts No. (name of area named on TOC)
- ### : Cluster } Address (Physical address on disc)
- ** : Sector }
- \$\$: Track mode (Track information such as copyright information of each part)

Reading the Retry Cause Display

Hexadecimal	Higher Bits				Lower Bits				Hexadecimal	Cause of Retry	Occurring conditions
	8	4	2	1	8	4	2	1			
Bit	b7	b6	b5	b4	b3	b2	b1	b0			
Binary	0	0	0	0	0	0	0	1	01	shock	When track jump (shock) is detected
	0	0	0	0	0	0	1	0	02	ader5	When ADER was counted more than five times continuously
	0	0	0	0	0	1	0	0	04	Discontinuous address	When ADIP address is not continuous
	0	0	0	0	1	0	0	0	08	DIN unlock	When DIN unlock is detected
	0	0	0	1	0	0	0	0	10	FCS incorrect	When not in focus
	0	0	1	0	0	0	0	0	20	IVR rec error	When ABCD signal level exceeds the specified range
	0	1	0	0	0	0	0	0	40	CLV unlock	When CLV is unlocked
	1	0	0	0	0	0	0	0	80	Access fault	When access operation is not performed normally

Reading the Display:

Convert the hexadecimal display into binary display. If more than two causes, they will be added.

Example

When 42 is displayed:
 Higher bit : 4 = 0100 → b6
 Lower bit : 2 = 0010 → b1
 In this case, the retry cause is combined of “CLV unlock” and “ader5”.

When A2 is displayed:
 Higher bit : A = 1010 → b7+b5
 Lower bit : 2 = 0010 → b1
 The retry cause in this case is combined of “Access fault”, “IVR rec error”, and “ader5”.

Reading the Track Mode Display

Hexadecimal	Higher Bits				Lower Bits				Hexa- decimal	Details	
	8	4	2	1	8	4	2	1		When 0	When 1
Bit	b7	b6	b5	b4	b3	b2	b1	b0			
Binary	0	0	0	0	0	0	0	1	01	Emphasis OFF	Emphasis ON
	0	0	0	0	0	0	1	0	02	Monaural	Stereo
	0	0	0	0	0	1	0	0	04	This is 2-bit display. Normally 01.	
	0	0	0	0	1	0	0	0	08	01:Normal audio. Others:Invalid	
	0	0	0	1	0	0	0	0	10	Audio (Normal)	Invalid
	0	0	1	0	0	0	0	0	20	Original	Digital copy
	0	1	0	0	0	0	0	0	40	Copyright	No copyright
	1	0	0	0	0	0	0	0	80	Write prohibited	Write allowed

Reading the Display:

Convert the hexadecimal display into binary display. If more than two causes, they will be added.

Example When 84 is displayed:

Higher bit : 8 = 1000 → b7

Lower bit : 4 = 0100 → b2

In this case, as b2 and b7 are 1 and others are 0, it can be determined that the retry cause is combined of “Emphasis OFF”, “Monaural”, “original”, “Copyright exists”, and “Write allowed”.

Example When 07 is displayed:

Higher bit : 0 = 0000 → All 0

Lower bit : 7 = 0111 → b0+b1+b2







In this case, as b0, b1, and b2 are 1 and others are 0, it can be determined that the retry cause is combined of “Emphasis ON”, “Stereo”, “Original”, “Copyright exists”, and “Write prohibited”.

Hexadecimal → Binary Conversion Table

Hexadecimal	Binary	Hexadecimal	Binary
0	0000	8	1000
1	0001	9	1001
2	0010	A	1010
3	0011	B	1011
4	0100	C	1100
5	0101	D	1101
6	0110	E	1110
7	0111	F	1111

Clearing the Retry Record:

Method:

1. Press the  button,  button, and  button for about 10 seconds.
2. Rotate the  knob to display “Retry Clear?” and press the  knob.
3. Press the  knob to clear the record and exit the clear mode.

Remote Parts Description

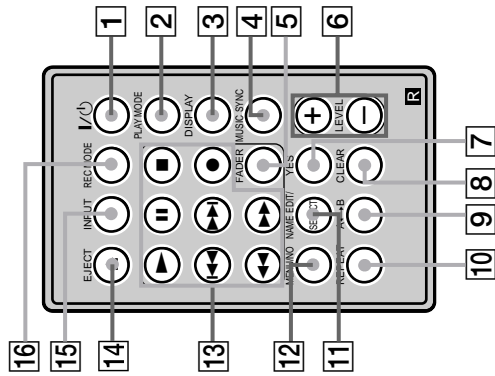

- 1 I/O (power) switch (12, 21)**
Press to turn the deck on. When you turn the deck on, the I/O switch indicator on the deck turns off. When you press the switch again, the deck turns off and the indicator lights up red.
- 2 PLAY MODE button (24, 25)**
Press to select Shuffle Play or Program Play.
- 3 DISPLAY button (6, 16, 25, 35)**
Press to select the information to be displayed in the window, or to select the type of characters to be input.
- 4 MUSIC SYNC button (20)**
Press to start Music Synchro-recording.
- 5 FADER button (42)**
Press to perform Fade-in Recording/Playback or Fade-out Recording/Playback.
- 6 LEVEL +/- buttons (14, 21)**
Press to adjust the recording level and the output level of the PHONES jack and ANALOG OUT jacks.
- 7 YES button (15, 25, 28)**
Press to carry out the selected operation.
- 8 CLEAR button (26, 36)**
Press to cancel the selection.

Location and Function of Parts Front Panel Parts Description

This chapter tells you about the location and function of the various buttons and controls on the front panel and the supplied remote. Further details are provided on the pages indicated in the parentheses. It also tells you about the information that appears in the display window.

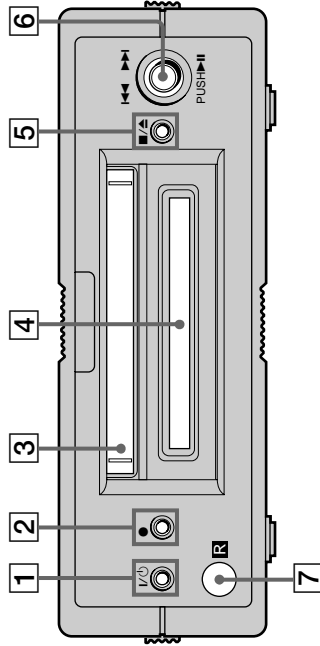

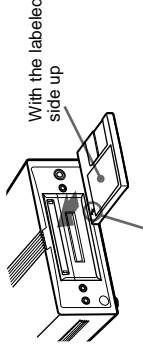
- 1 I/O (power) switch (12, 21)**
Press to turn the deck on. When you turn the deck on, the switch indicator turns off. When you press the switch again, the deck turns off and the indicator lights up red.
- 2 ● button (13, 17, 18)**
Press to record on the MD, monitor the input signal, or mark track numbers.
- 3 MD insertion slot**
Insert the MD as illustrated below.

- 4 Display window (6, 7)**
Shows various information.
- 5 ■/▲ button (13, 21, 29)**
Press to stop play, stop recording, or cancel the selected operation.
Press to eject the MD while the deck is stopped.
- 6 ◀◀/▶▶ control, ▶|| button (13, 21, 22, 25, 28)**
Turn to locate tracks.
Press to start play, pause play, or pause recording.
Press to carry out the selected operation.
- 7 Remote sensor**
Point the remote towards this window (R) for remote operations.

Location and Function of Parts

- 9 A↔B button (23)**
Press to select Repeat A-B Play.
- 10 REPEAT button (23)**
Press to play tracks repeatedly.
- 11 NAME EDIT/SELECT button (37)**
Press to add the name or change the name of a track or MD.
- 12 MENU/NO button (15, 25, 28)**
Press to display "Edit Menu" or "Setup Menu."
- 13 ▶ button (13, 21)**
Press to start play or recording.
- || button (13, 21)**
Press to pause play or recording. Press again to resume play or recording.
- button (13, 21, 29)**
Press to stop play, recording, or cancel the selected operation.
- ◀◀/▶▶ buttons (13, 21, 22, 25, 28)**
Press to locate tracks, select a menu item, or select a character to be input.
- button (13, 17, 18)**
Press to record on the MD, monitor the input signal, or mark track numbers.
- ◀◀/▶▶ buttons (22, 26, 36)**
Press to locate a portion within a track, change the contents of a program, or shift the cursor.
- 14 EJECT ▲ button (13, 21)**
Press to eject the MD.
- 15 INPUT button (12)**
Press to select the input jack (or connector) of the program source to be recorded.
- 16 REC MODE button (15)**
Press to select one of the following four recording modes: Mono (monaural recording), stereo (stereo recording), LP2 (2 times normal recording time), and LP4 (4 times normal recording time).

SECTION 2 GENERAL

This section is extracted from instruction manual.

While the deck is recording

Press DISPLAY repeatedly to change the display. Each press of the button changes the display as follows:

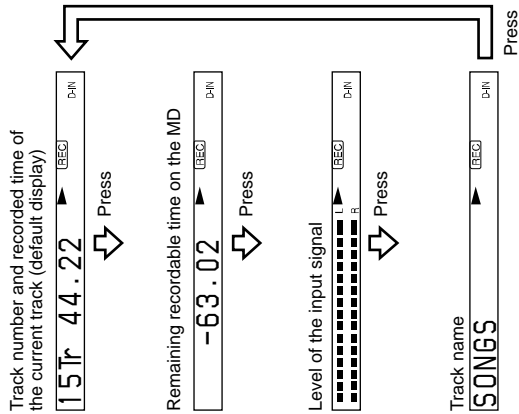

While the deck is playing

Press DISPLAY repeatedly to change the display. Each press of the button changes the display as follows:

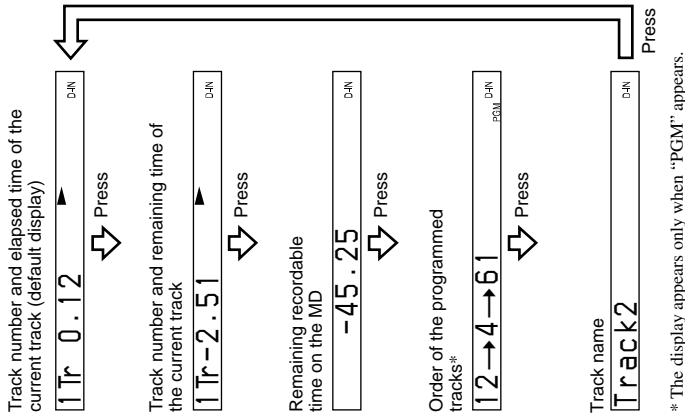

* The display appears only when "PGM" appears.

Using the Display

The display window shows information about the MD or track. This section describes the information that appears for each deck status.

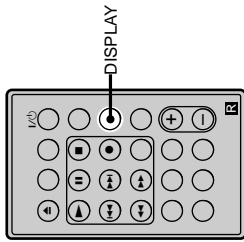

Note

The type of information (e.g., total number of tracks, recorded time, remaining time, track or disc name) which was last displayed will continue to appear until you change it by pressing DISPLAY, even if you change the deck operation status. For example, if the remaining time was displayed when you stop the deck, the remaining time will continue to appear when you begin playing the same MD again or a different one.

When you insert an MD

The display automatically changes as follows:

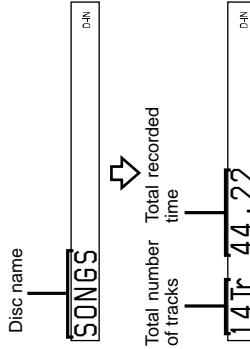

While the deck is stopped

Press DISPLAY repeatedly to change the display. Each press of the button changes the display as follows:

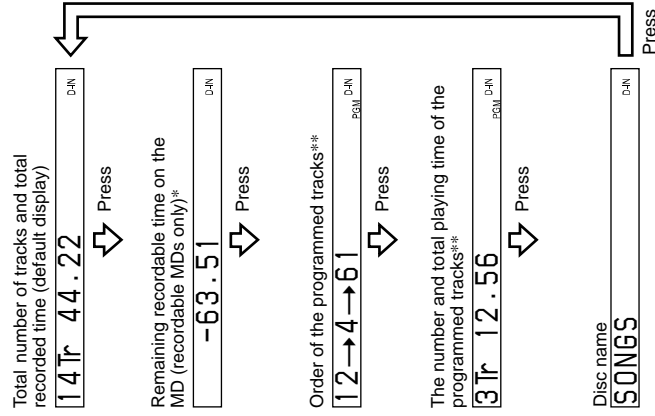

* Not shown for the premastered discs.

** This display appears only when "PGM" appears.

Location and Function of Parts

Hooking Up

The MD deck can be connected to PCs with PC LINK capability (such as the VAIO-series of PCs), peripheral devices such as portable CD players, and active speakers. Make sure all devices are turned off before you hook them up.

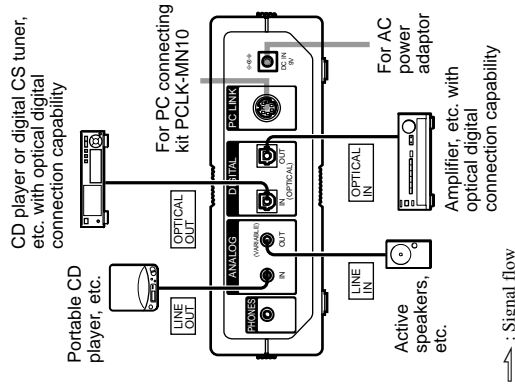

Connecting the MD deck to a personal computer

Use the PCLK-MN10 PC connecting kit (supplied) to connect the PC to the MD deck through the PC LINK jack on the back of the MD deck. By connecting the MD deck to a PC, you will be able to select and play MD tracks and do various editing operations on the PC screen. For more details, refer to the manual supplied with the PC connecting kit.

Connecting the MD deck with an audio component

The MD deck is capable of recording from both analog and digital sources.

When recording from an analog source

Required connecting cord

Audio connecting cord (supplied)

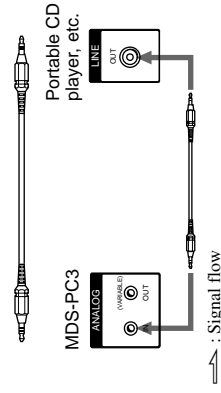

When recording from a digital source

Required connecting cord

Optical digital cable (supplied)

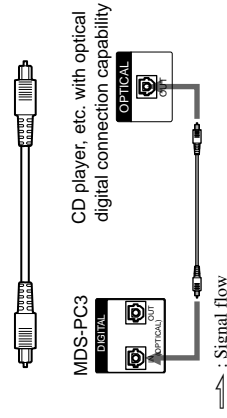

continued

SECTION 3 DISASSEMBLY

Note : Follow the disassembly procedure in the numerical order given.

3-1. CASE (U)

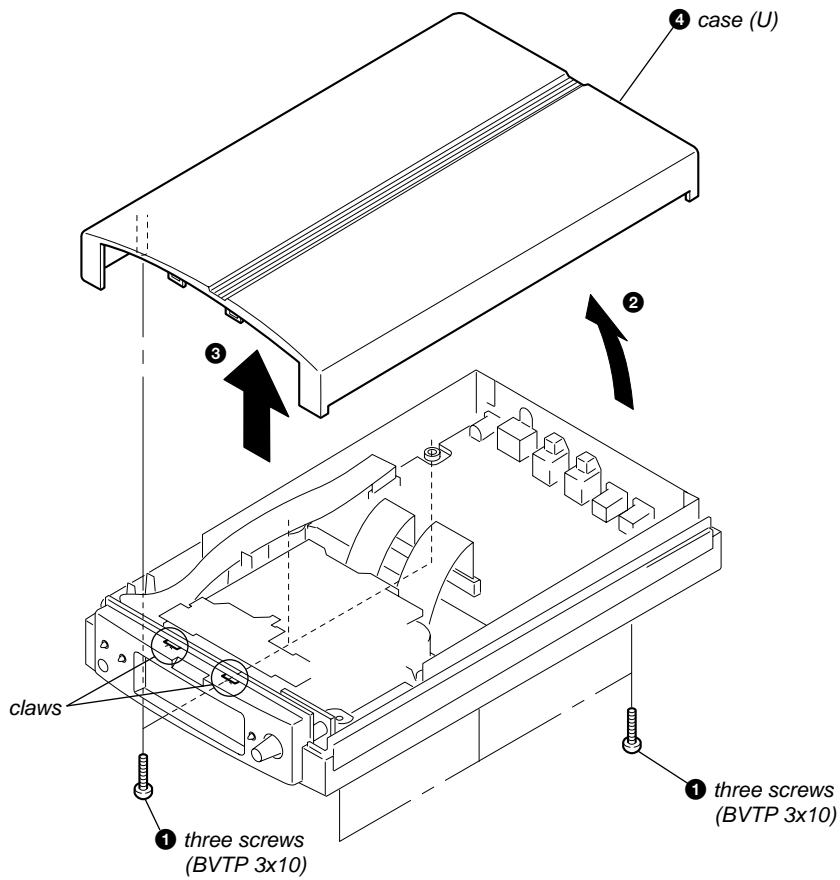

3-2. MD MECHANISM DECK (MDM-7A)

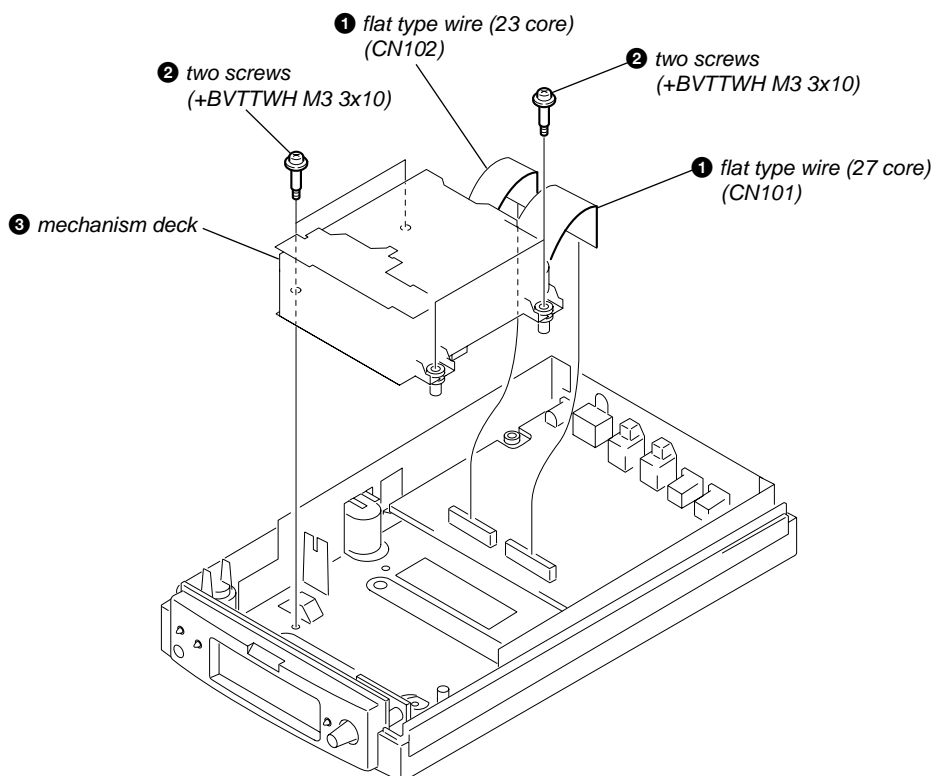

3-3. MAIN BOARD

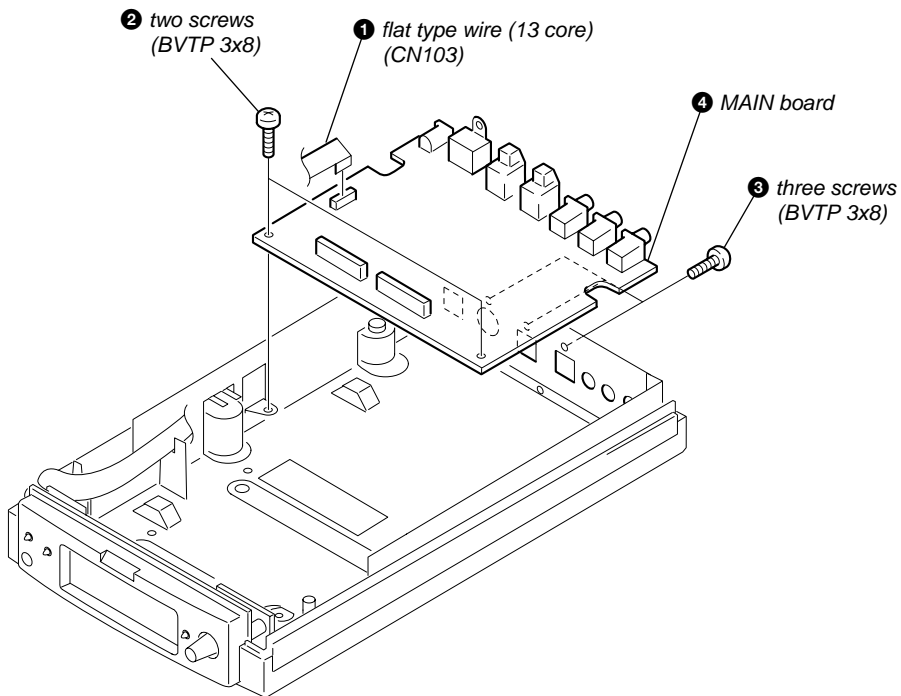

3-4. OVER LIGHT HEAD (HR901), BD (MD) BOARD

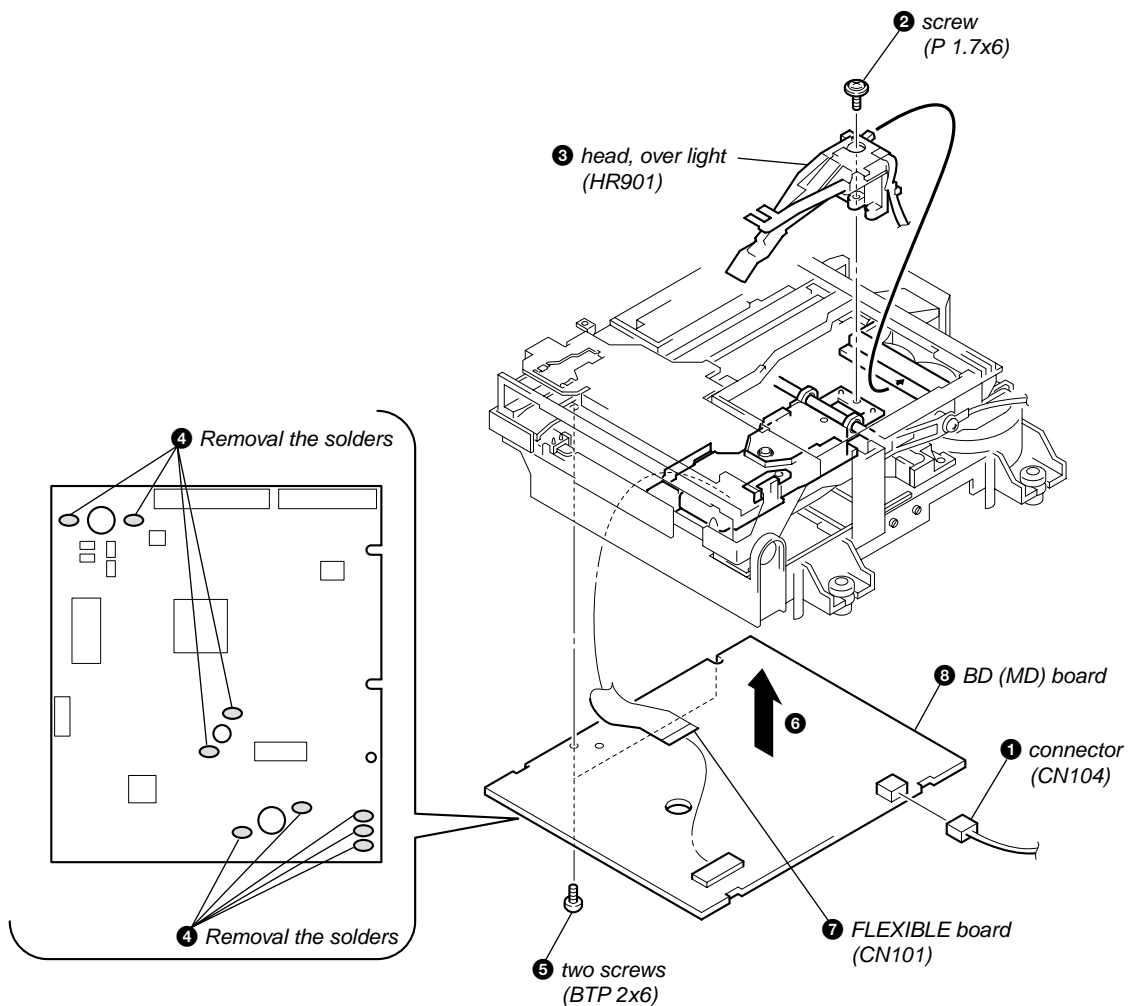

3-5. HOLDER ASSY

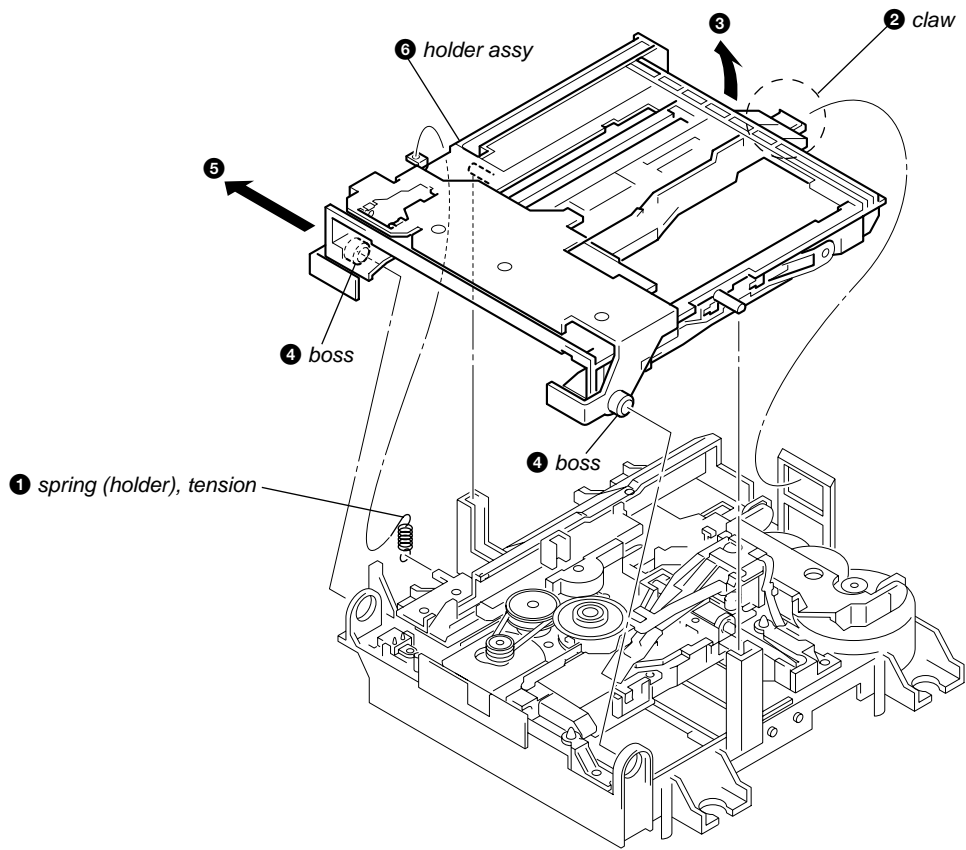

3-6. LOADING MOTOR ASSY (M103)

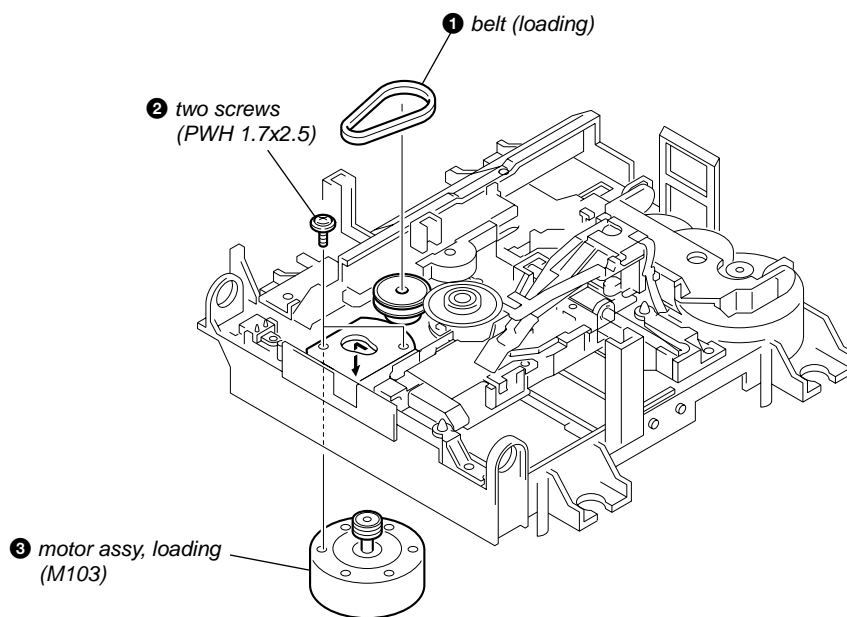

3-7. SLED MOTOR ASSY (M102), SLIDER

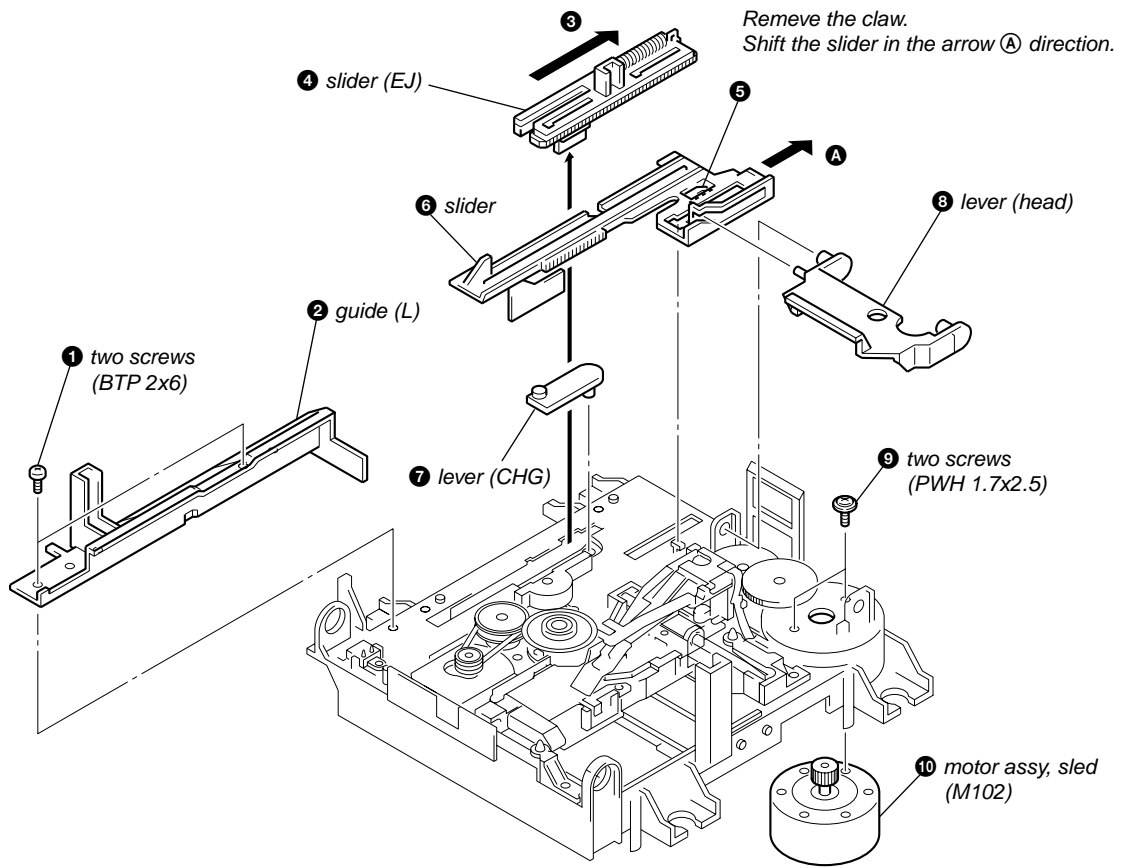

3-8. OPTICAL PICK-UP (MD) (KMS-260B/JIN)

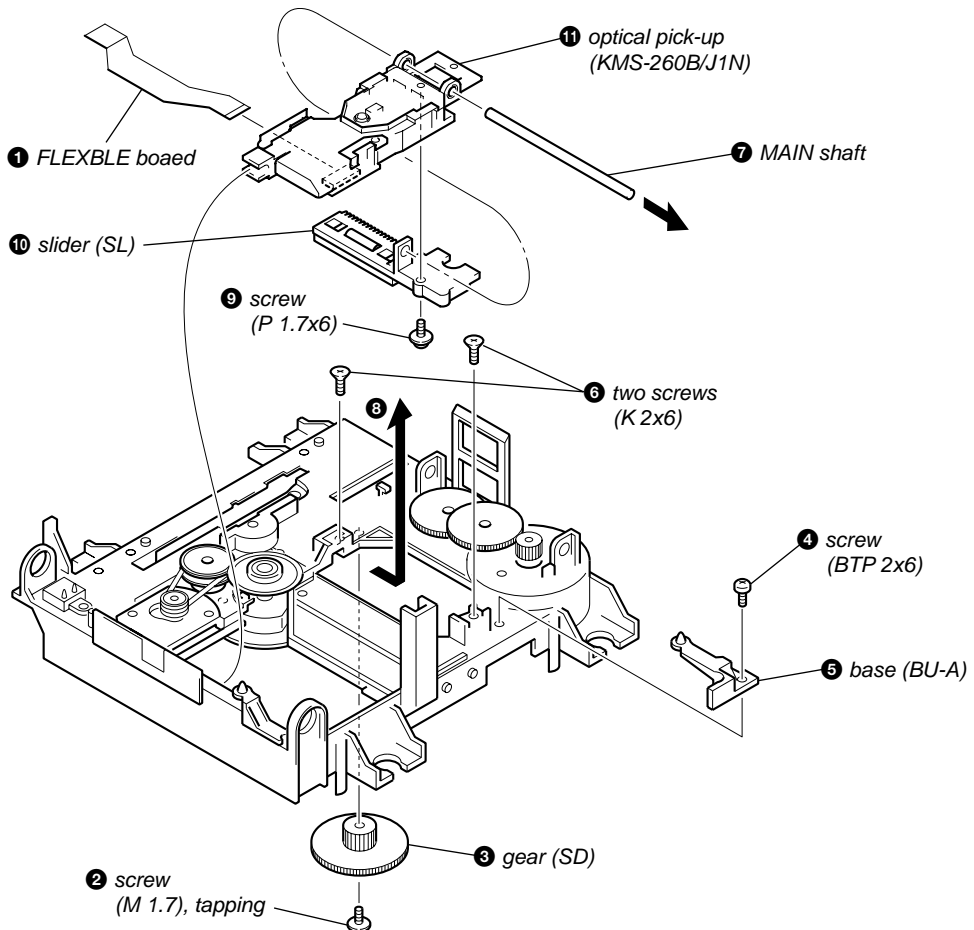



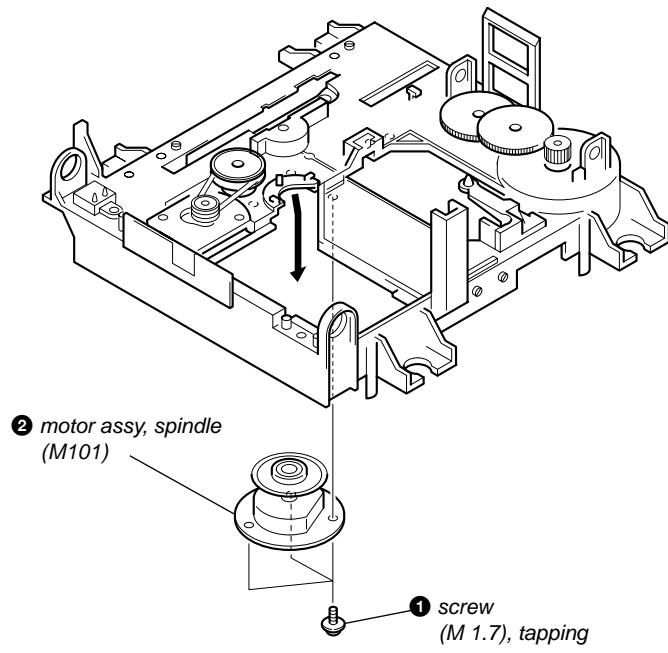





3-9. SPINDLE MOTOR ASSY (M101)



SECTION 4 TEST MODE

***Note:**

As this unit has only a few buttons, one button is assigned with several functions in the test mode.”
Press the  button,  knob to switch the functions.







- Each time the  button is pressed, the display switches in the following order, “PGM” → “blank” → “PGM” → —.
- Rotate the  knob and the display switches in the following order, “blank” → “TOC” → “EDIT” → “TOC EDIT” → “” → “” → “” → “” → “blank” → —.

For simplicity, operations of  button will not be described here.

Example)  : Lights-out “PGM” and press the  button.
 “PGM” : Display “PGM” and press the  button.

The functions of each button change with the display.

Buttons and Corresponding Functions

Buttons	“PGM” displayed	“PGM” Lights-out							
		LCD displayed							
		Nothing displayed	TOC	EDIT	TOC EDIT				
		ENTER (YES)	REPEAT	PLAY	CLEAR	FF	PLAY MODE	DISPLAY	—
	EJECT	MENU (EDIT)/ NO	STOP	REC	—	FR	SCROLL	TIME	—

4-1. PRECAUTIONS FOR USE OF TEST MODE





- As loading related operations will be performed regardless of the test mode operations being performed, be sure to check that the disc is stopped before setting and removing it.

4-1-1. Recording laser emission mode and operating buttons

- Continuous recording mode (CREC 1MODE) (C35)
- Laser power check mode (LDPWR CHECK) (C13)
- Laser power adjustment mode (LDPWR ADJUS) (C04)
- Top check (Iop Compare) (C27)
- Top value nonvolatile writing (Iop NV Save) (C06)
- Traverse (MO) check (EF MO CHECK) (C14)
- Traverse (MO) adjustment (EF MO ADJUS) (C07)
- When pressing the  button.

4-2. SETTING THE TEST MODE

The following are two methods of entering the test mode.

While pressing the  knob and  button, connect the power plug to an outlet, and release the  knob and  button.
When the test mode is set, “[Check]” will be displayed. Rotating the AMS knob switches between the following three groups;
... ↔ Check ↔ Service ↔ Develop ↔ ...

NOTE: Do not use the test mode in the [Develop] group.

If used, the unit may not operate normally.

If the [Develop] group is set accidentally, press the  button immediately to exit the [Develop] group.



4-3. EXITING THE TEST MODE

Press the  button, remove the power plug to the outlet.

4-4. BASIC OPERATIONS OF THE TEST MODE

All operations are performed using the  knob,  button, and  button.

The functions of these buttons are as follows.

Function name		Function
		Cancel or move to top hierarchy
		Set
AMS knob	Left or Right	Select
	Push 	Set submenu

4-5. SELECTING THE TEST MODE

There are 26 types of test modes as shown below. The groups can be switched by rotating the [AMS] knob. After selecting the group to be used, press the [I/O] button. After setting a certain group, rotating the [AMS] knob switches between these modes.

Refer to “Group” in the table for details selected.

All adjustments and checks during servicing can be performed in the test mode in the Service group.

NOTE: Do not use the test mode in the [Develop] group.

If used, the unit may not operate normally.

If the [Develop] group is set accidentally, press the [■/▲] button immediately to exit the [Develop] group.

Display	No.	Details	Mark	Group	
				Check	Service
AUTO CHECK	C01	Automatic self-diagnosis			○
Err Display	C02	Error history display, clear			○
TEMP ADJUST	C03	Temperature compensation offset adjustment			○
LDPWR ADJUST	C04	Laser power adjustment			○
Iop Write	C05	Iop data writing			○
Iop NV Save	C06	Writes current Iop value in read nonvolatile memory using microprocessor			○
EF MO ADJUST	C07	Traverse (MO) adjustment			○
EF CD ADJUST	C08	Traverse (CD) adjustment			○
FBIAS ADJUST	C09	Focus bias adjustment			○
AG Set (MO)	C10	Focus, tracking gain adjustment (MO)			○
AG Set (CD)	C11	Focus, tracking gain adjustment (CD)			○
TEMP CHECK	C12	Temperature compensation offset check		○	○
LDPWR CHECK	C13	Laser power check		○	○
EF MO CHECK	C14	Traverse (MO) check		○	○
EF CD CHECK	C15	Traverse (CD) check		○	○
FBIAS CHECK	C16	Focus bias check		○	○
ScurveCHECK	C17	S-curve check	×	○	
VERIFYMODE	C18	Nonvolatile memory check	×	○	
DETRK CHECK	C19	Detrack check	×	○	
0920 CHECK	C25	Most circumference check	×	○	
Iop Read	C26	Iop data display		○	○
Iop Compare	C27	Comparison with initial Iop value written in nonvolatile memory		○	○
ADJ CLEAR	C28	Initialization of nonvolatile memory for adjustment values			○
INFORMATION	C31	Display of microprocessor version, etc.		○	○
CPLAY1MODE	C34	Continuous playback mode		○	○
CREC 1MODE	C35	Continuous recording mode		○	○

- For details of each adjustment mode, refer to “5. Electrical Adjustments”.
For details of “Err Display”, refer to “Self-Diagnosis Function” on page 2.
- If a different mode has been selected by mistake, press the [■/▲] button to exit that mode.
- Modes with (X) in the Mark column are not used for servicing and therefore are not described in detail. If these modes are set accidentally, press the [■/▲] button to exit the mode immediately.

4-5-1. Operating the Continuous Playback Mode

1. Entering the continuous playback mode
 - ① Set the disc in the unit. (Whichever recordable discs or discs for playback only are available.)
 - ② Rotate the **[AMS]** knob and display “CPLAY1MODE”(C34).
 - ③ Press the **[I/⏪]** button to change the display to “CPLAY1 MID”.
 - ④ When access completes, the display changes to “C = [] AD = []”.

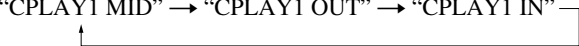
Note : The numbers “[]” displayed show you error rates and ADER.
2. Changing the parts to be played back
 - ① Press the **[I/⏪]** button during continuous playback to change the display as below.
 “CPLAY1 MID” → “CPLAY1 OUT” → “CPLAY1 IN”

 - When pressed another time, the parts to be played back can be moved.
 - ② When access completes, the display changes to “C = [] AD = []”.

Note : The numbers “[]” displayed show you error rates and ADER.
3. Ending the continuous playback mode
 - ① Press the **[■/▲]** button. The display will change to “CPLAY1MODE”(C34).
 - ② Press the **[■/▲]“PGM”** button to remove the disc.

Note : The playback start addresses for IN, MID, and OUT are as follows.

IN	40h cluster
MID	300h cluster
OUT	700h cluster

4-5-2. Operating the Continuous Recording Mode (Use only when performing self-recording/palyback check.)

1. Entering the continuous recording mode
 - ① Set a recordable disc in the unit.
 - ② Rotate the **[AMS]** knob and display “CREC 1MODE” (C35).
 - ③ Press the **[I/⏪]** button to change the display to “CREC1 MID”.
 - ④ When access completes, the display changes to “CREC1 ([])” and **REC** lights up.

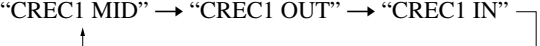
Note : The numbers “[]” displayed shows you the recording position addresses.
2. Changing the parts to be recorded
 - ① When the **[I/⏪]** button is pressed during continuous recording, the display changes as below.
 “CREC1 MID” → “CREC1 OUT” → “CREC1 IN”

 - When pressed another time, the parts to be recorded can be changed. **REC** goes off.
 - ② When access completes, the display changes to “CREC1 ([])” and **REC** lights up.

Note : The numbers “[]” displayed shows you the recording position addresses.
3. Ending the continuous recording mode
 - ① Press the **[■/▲]** button. The display changes to “CREC 1MODE” (C35) and **REC** goes off.
 - ② Press the **[■/▲]“PGM”** button to remove the disc.

Note 1 : The recording start addresses for IN, MID, and OUT are as follows.

IN	40h cluster
MID	300h cluster
OUT	700h cluster

Note 2 : The **[■/▲]** button can be used to stop recording anytime.

Note 3 : Do not perform continuous recording for long periods of time above 5 minutes.

Note 4 : During continuous recording, be careful not to apply vibration.

4-6. FUNCTIONS OF OTHER BUTTONS

Function	Contents
PLAY	Sets continuous playback when pressed in the STOP state. When pressed during continuous playback, the tracking servo turns ON/OFF.
STOP	Stops continuous playback and continuous recording.
FF	The sled moves to the outer circumference only when this is pressed.
FR	The sled moves to the inner circumference only when this is pressed.
SCROLL	Switches between the pit and groove modes when pressed.
PLAYMODE	Switches the spindle servo mode (CLV S ↔ CLV A).
DISPLAY	Switches the displayed contents each time the button is pressed.
■/▲ “PGM”	Ejects the disc.
■/▲	Exits the test mode.
REPEAT	Resets the software.
REC	Switches between recording start and stop if all servos are ON
CLEAR	Differentiates the disc type (High reflective aluminum: CD/low reflection: MD)
TIME	Switches between the error rate and motor modes

4-7. TEST MODE DISPLAYS

Each time the **DISPLAY** button is pressed, the display changes in the following order.

When CPLAY and CREC are started, the display will forcibly be switched to the error rate display as the initial mode.

1. Mode display

Displays “TEMP ADJUST” (C03), “CPLAY1MODE” (C34), etc.

2. Error rate display

Displays the error rate in the following way.

C = □□□□ AD = □□

C = Indicates the C1 error.

AD = Indicates ADER.

3. Address display

The address is displayed as follows. (MO:recordable disc, CD:playback only disc)

Pressed the **SCROLL** button, the display switches from groove to pit or vice versa.

h = □□□□ s = □□□□ (MO pit and CD)

h = □□□□ a = □□□□ (MO groove)

h = Indicates the header address.

s = Indicates the SUBQ address.

a = Indicates the ADIP address.

Note: “-” is displayed when the address cannot be read.

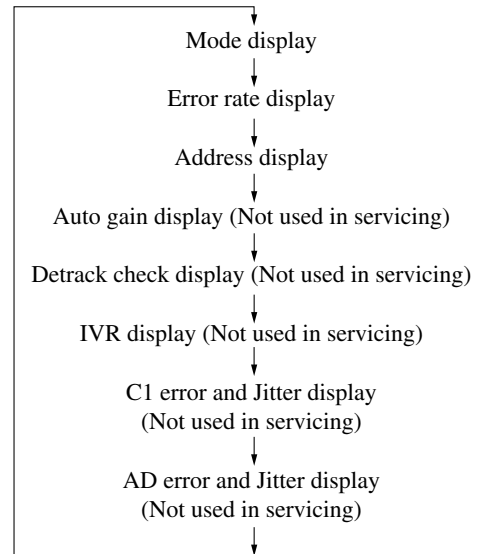

4-8. MEANINGS OF OTHER DISPLAYS

Display	Contents	
	When Lit	When Off
▶	Servo ON	Servo OFF
	Tracking servo OFF	Tracking servo ON
REC ●	Recording mode ON	Recording mode OFF
LP	CLV low speed mode	CLV normal mode
L.SYNC	ABCD adjustment completed	
ATT	Tracking offset cancel ON	Tracking offset cancel OFF
B	Tracking auto gain OK	
A-	Focus auto gain OK	
4	Pit	Groove
2	High reflection	Low reflection
SHUF	CLV S	CLV A
MONO	CLV LOCK	CLV UNLOCK

4-9. AUTOMATIC SELF-DIAGNOSIS FUNCTION

This test mode performs CREC and CPLAY automatically for mainly checking the characteristics of the optical pick-up. To perform this test mode, the laser power must first be checked. Perform AUTO CHECK after the laser power check and Iop check.

Procedure

1. Press the  button. If “LDPWR ミチェック ” is displayed, it means that the laser power check has not been performed. In this case, perform the laser power check and Iop compare, and then repeat from step 1.
2. If a disc is in the mechanical deck, it will be ejected forcibly.
“DISC IN” will be displayed in this case. Load a test disc (MDW-74/GA-1) which can be recorded.
3. If a disc is loaded at step 2, the check will start automatically.
4. When “XX CHECK” is displayed, the item corresponding to XX will be performed.
When “06 CHECK” completes, the disc loaded at step 2 will be ejected. “DISC IN” will be displayed. Load the check disc (MD) TDYS-1.
5. When the disc is loaded in step 4, the check will automatically be resumed from “07 CHECK”.
6. After completing to test item 12, check OK or NG will be displayed. If all items are OK, “CHECK ALL OK” will be displayed. If any item is NG, it will be displayed as “NG:xxxx”.



When “CHECK ALL OK” is displayed, it means that the optical pick-up is normal. Check the operations of the other spindle motor, thread motor, etc.

When displayed as “NG:xxxx”, it means that the optical pick-up is faulty. In this case, replace the optical pick-up.

4-10. INFORMATION

Display the software version.

Procedure

1. If displayed as “INFORMATION” (C31), press the  button.
2. The software version will be displayed.
3. Press the  button to end this mode.

SECTION 5 ELECTRICAL ADJUSTMENTS

5-1. PARTS REPLACEMENT AND ADJUSTMENT

If malfunctions caused by optical pick-up such as sound skipping are suspected, follow the following check.

Check before replacement

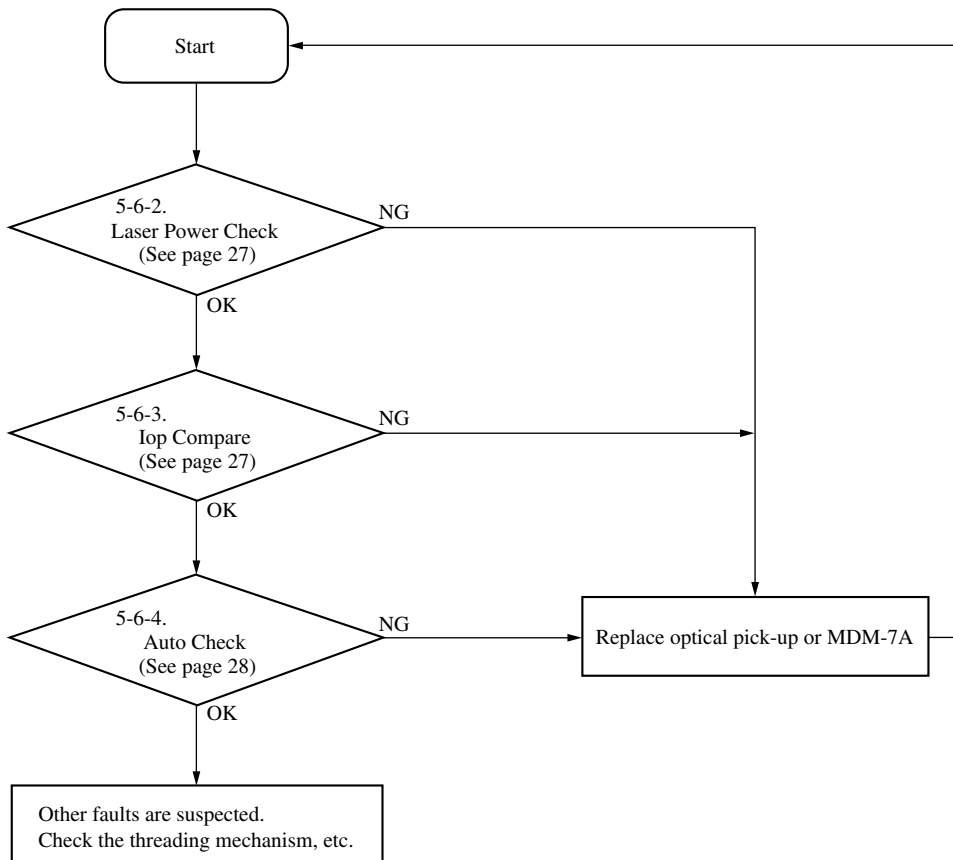

Adjustment flow

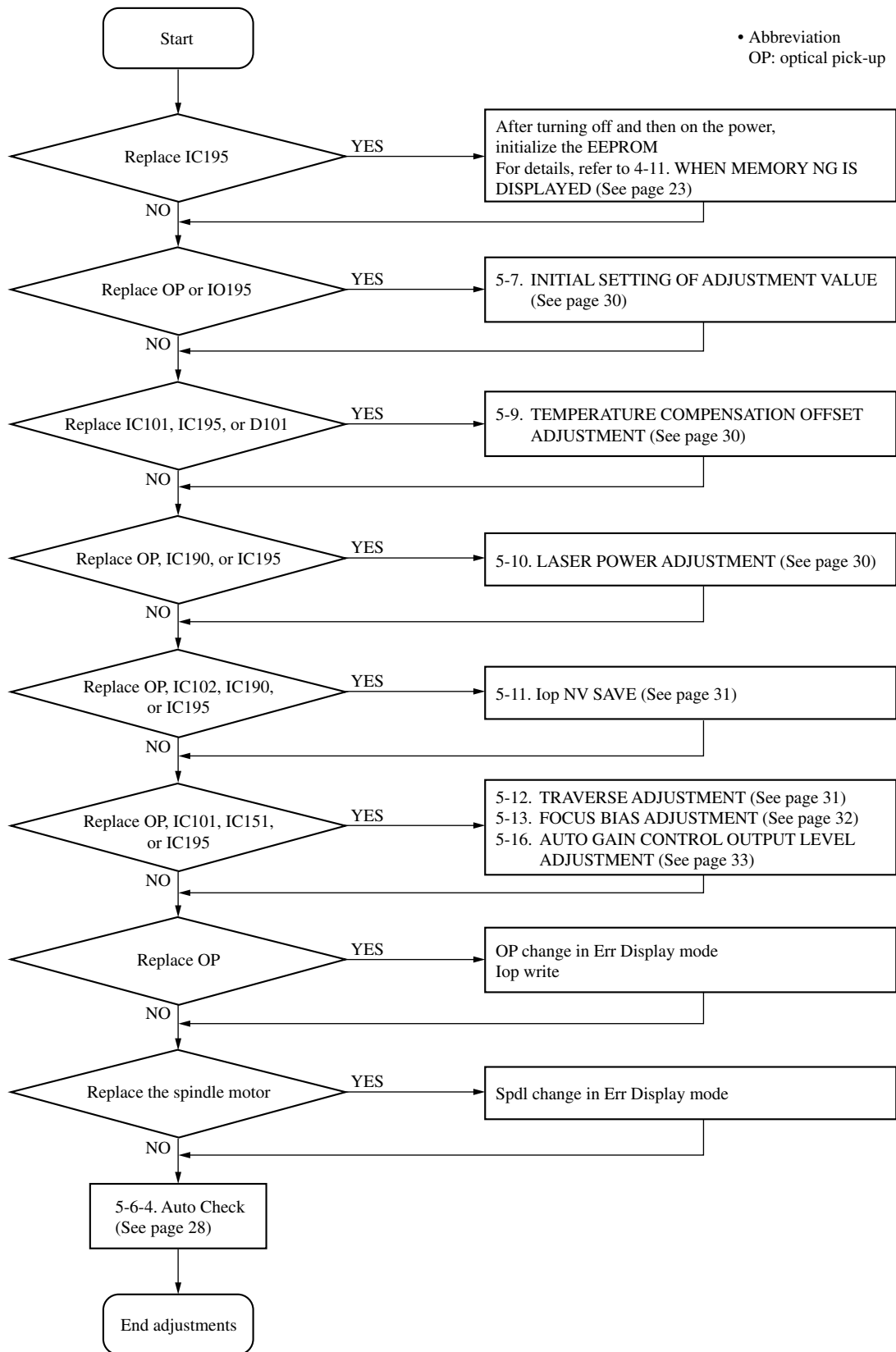

5-2. PRECAUTIONS FOR CHECKING LASER DIODE EMISSION

To check the emission of the laser diode during adjustments, never view directly from the top as this may lose your eye-sight.

5-3. PRECAUTIONS FOR USE OF OPTICAL PICK-UP (KMS-260B)

As the laser diode in the optical pick-up is easily damaged by static electricity, solder the laser tap of the flexible board when using it. Before disconnecting the connector, desolder first. Before connecting the connector, be careful not to remove the solder. Also take adequate measures to prevent damage by static electricity. Handle the flexible board with care as it breaks easily.

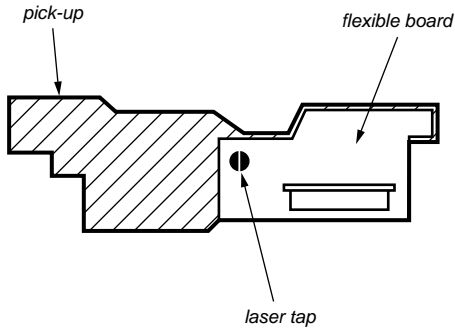

Optical pick-up flexible board

5-4. PRECAUTIONS FOR ADJUSTMENTS

- 1) When replacing the following parts, perform the adjustments and checks with ○ in the order shown in the following table.
- 2) Set the test mode when performing adjustments.
After completing the adjustments, exit the test mode.
Perform the adjustments and checks in "group S" of the test mode.
- 3) Perform the adjustments to be needed in the order shown.
- 4) Use the following tools and measuring devices.
 - Check Disc (MD) TDYS-1 (Parts No. 4-963-646-01)
 - Test Disk (MDW-74/GA-1) (Parts No. 4-229-747-01)
 - Laser power meter LPM-8001 (Parts No. J-2501-046-A)
or
 - MD Laser power meter 8010S (Parts No. J-2501-145-A)
 - Oscilloscope (Measure after performing CAL of prove.)
 - Digital voltmeter
 - Thermometer
 - Jig for checking BD board waveform (Parts No. : J-2501-196-A)
- 5) When observing several signals on the oscilloscope, etc., make sure that VC and ground do not connect inside the oscilloscope.
(VC and ground will become short-circuited.)
- 6) Using the above jig enables the waveform to be checked without the need to solder.
(Refer to Servicing Note on page 6.)
- 7) As the disc used will affect the adjustment results, make sure that no dusts nor fingerprints are attached to it.

Adjustment	Parts to be replaced						
	optical pick-up	IC101	IC102	IC151	IC190	IC195	D101
5-7. INITIAL SETTING OF ADJUSTMENT VALUES	○	×	×	×	×	○	×
5-8. RECORDING OF Iop INFORMATION	○	×	×	×	×	○	×
5-9. TEMP COMPENSATION OFF SET ADJUST	×	○	×	×	×	○	○
5-10. LASER POWER ADJUSTMENT	○	×	×	×	○	○	×
5-11. Iop NV SAVE	○	×	○	×	○	○	×
5-12. TRAVERSE ADJUSTMENT	○	○	×	○	×	○	×
5-13. FOCUS BIAS ADJUSTMENT	○	○	×	○	×	○	×
5-16. AUTO GAIN ADJUSTMENT	○	○	×	○	×	○	×
5-6-4. Auto Check	○	○	×	○	○	○	×

5-5. USING THE CONTINUOUSLY RECORDED DISC

* This disc is used in focus bias adjustment and error rate check.
The following describes how to create a continuous recording disc.

1. Insert a disc (blank disc) commercially available.
2. Rotate the [AMS] knob and display "CREC 1MODE" (C35).
3. Press the [I/O] button again to display "CREC1 MID".
Display "CREC (0300)" and start to recording.
4. Complete recording within 5 minutes.
5. Press the [■/▲] button and stop recording.
6. Press the [■/▲] "PGM" button and remove the disc.

The above has been how to create a continuous recorded data for the focus bias adjustment and error rate check.

Note :

- Be careful not to apply vibration during continuous recording.

5-6. CHECKS PRIOR TO REPAIRS

These checks are performed before replacing parts according to "approximate specifications" to determine the faulty locations. For details, refer to "Checks Prior to Parts Replacement and Adjustments" (See page 8).

5-6-1. Temperature Compensation Offset Check

When performing adjustments, set the internal temperature and room temperature to 22 to 28°C.

Checks cannot be performed properly if performed after some time from power ON due to the rise in the temperature of the IC and diode, etc. So, perform the checks again after waiting some time.

Checking Procedure:

1. Rotate the [AMS] knob to display "TEMP CHECK" (C12).
2. Press the [I/O] button.
3. "T=@@ (##) [OK]" should be displayed. If "T=@@ (##) [NG]" is displayed, it means that the results are bad.
(@@ indicates the current value set, and ## indicates the value written in the non-volatile memory.)

5-6-2. Laser Power Check

Before checking, check Iop value of the optical pick-up.
(Refer to 5-8. Recording and Displaying Iop Information.)

Connection :

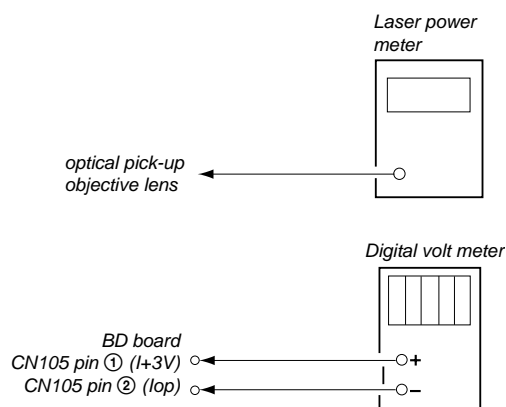

Checking Procedure:

1. Set the laser power meter on the objective lens of the optical pick-up.
Connect the digital volt meter to CN105 pin ① (+3V) and CN105 pin ② (Iop).
2. Then, rotate the [AMS] knob and display "LDPWR CHECK" (C13).
3. Press the [I/O] button once and display "LD 0.9 mW \$ 000".
Check that the reading of the laser power meter become 0.84 to 0.92 mW.
4. Press the [I/O] button once more and display "LD 7.0 mW \$ 000".
Check that the reading the laser power meter and digital volt meter satisfy the specified value.

Specified Value :

Laser power meter reading : 7.0 ± 0.2 mW

Digital voltmeter reading : Optical pick-up displayed value ± 10%

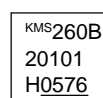

(For details of the method for checking this value, refer to "5-8. Recording and Displaying Iop Information".)

Iop = 57.6 mA in this case

Iop (mA) = Digital voltmeter reading (mV)/1 (Ω)

(Optical pick-up label)

5. Press the [■/▲] button and display "LDPWR CHECK" (C13) and stop the laser emission.
(The [■/▲] button is effective at all times to stop the laser emission.)

Note 1: After step 4, each time the [I/O] button is pressed, the display will be switched between "LD 0.7 mW \$ 000", "LD 6.2 mW \$ 000", and "LD Wp ホセイ \$ 000". Nothing needs to be performed here.

5-6-3. Iop Compare

The current Iop value at laser power 7 mw output and reference Iop value (set at shipment) written in the nonvolatile memory are compared, and the rate of increase/decrease will be displayed in percentage.

Note: Perform this function with the optical pick-up set at room temperature.

Procedure

1. Rotate the [AMS] knob to display "Iop Compare" (C27).
2. Press the [I/O] button and start measurements.
3. When measurements complete, the display changes to "±xx%yy".
xx is the percentage of increase/decrease, and OK or NG is displayed at yy to indicate whether the percentage of increase/decrease is within the allowable range.
4. Press the [■/▲] button to end.

5-6-4. Auto Check

This test mode performs CREC and CPLAY automatically for mainly checking the characteristics of the optical pick-up. To perform this test mode, the laser power must first be checked. Perform Auto Check after the laser power check and Iop compare.

Procedure

1. Press the button. If "LDPWR minicheck" is displayed, it means that the laser power check has not been performed. In this case, perform the laser power check and Iop compare, and then repeat from step 1.
2. If a disc is in the mechanical deck, it will be ejected forcibly. "DISC IN" will be displayed in this case. Load a test disc (MDW-74/GA-1) which can be recorded.
3. If a disk is loaded at step 2, the check will start automatically.
4. When "XX CHECK" is displayed, the item corresponding to XX will be performed.
When "06 CHECK" completes, the disc loaded at step 2 will be ejected. "DISC IN" will be displayed. Load the check disc (MD) TDYS-1.
5. When the disc is loaded, the check will automatically be resumed from "07 CHECK".
6. After completing to test item 12, check OK or NG will be displayed. If all items are OK, "CHECK ALL OK" will be displayed. If any item is NG, it will be displayed as "NG:xxxx".

When "CHECK ALL OK" is displayed, it means that the optical pick-up is normal. Check the operations of the other spindle motor, thread motor, etc.

When displayed as "NG:xxxx", it means that the optical pick-up is faulty. In this case, replace the optical pick-up.

5-6-5. Other Checks

All the following checks are performed by the Auto Check mode. They therefore need not be performed in normal operation.

5-6-6. Traverse Check

5-6-7. Focus Bias Check

5-6-8. C PLAY Check

5-6-9. Self-Recording/Playback Check

5-6-6. Traverse Check

Connection :

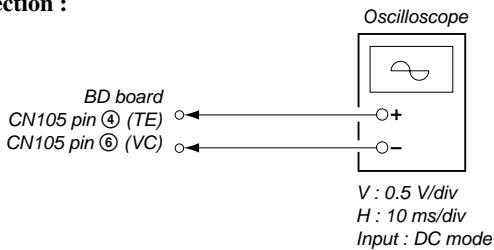

Checking Procedure:

1. Connect an oscilloscope to CN105 pin ④ (TE) and CN105 pin ⑥ (VC) of the BD board.
2. Load a test disc (MDW-74/GA-1). (Refer to Note 1.)
3. Rotate the knob and display "EF MO CHECK" (C14).
4. Press the button and display "EFB = MO-R".
(Laser power READ power/Focus servo ON/tracking servo OFF/spindle (S) servo ON)

5. Observe the waveform of the oscilloscope, and check that the specified value is satisfied. Do not rotate the knob.
(Read power traverse checking)

(Traverse Waveform)

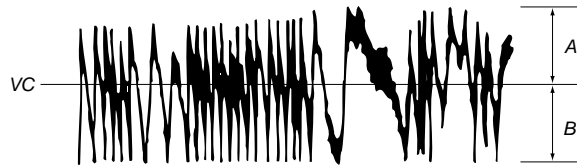

Specified value : Below 10% offset value

$$\text{Offset value (\%)} = \frac{|A - B|}{2(A + B)} \times 100$$

6. Press the button and display "EFB = MO-W".
7. Observe the waveform of the oscilloscope, and check that the specified value is satisfied. Do not rotate the knob.
(Write power traverse checking)

(Traverse Waveform)

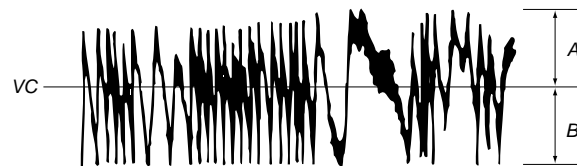

Specified value : Below 10% offset value

$$\text{Offset value (\%)} = \frac{|A - B|}{2(A + B)} \times 100$$

8. Press the button display "EFB = MO-P".
Then, the optical pick-up moves to the pit area automatically and servo is imposed.
9. Observe the waveform of the oscilloscope, and check that the specified value is satisfied. Do not rotate the knob.

(Traverse Waveform)

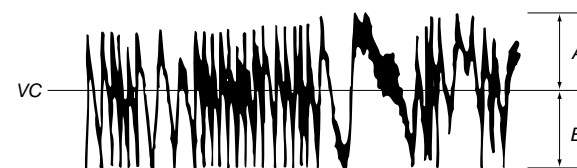

Specified value : Below 10% offset value

$$\text{Offset value (\%)} = \frac{|A - B|}{2(A + B)} \times 100$$

10. Press the button display "EF MO CHECK" (C14)
The disc stops rotating automatically.
11. Press the "PGM" button and remove the disc.
12. Load the check disc (MD) TDYS-1.
13. Rotate the knob and display "EF CD CHECK" (C15).
14. Press the button and display "EFB = CD". Servo is imposed automatically.

- Observe the waveform of the oscilloscope, and check that the specified value is satisfied. Do not rotate the **[AMS]** knob.

(Traverse Waveform)

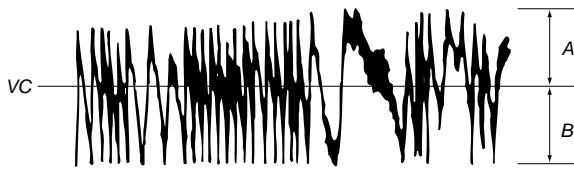

Specified value : Below 10% offset value

$$\text{Offset value (\%)} = \frac{|A - B|}{2(A + B)} \times 100$$

- Press the **[I/⏻]** button and display “EF CD CHECK” (C15).
- Press the **[■/▲ “PGM”]** button and remove the check disc (MD) TDYS-1.

Note 1 : MO reading data will be erased during if a recorded disc is used in this adjustment.

Note 2 : If the traverse waveform is not clear, connect the oscilloscope as shown in the following figure so that it can be seen more clearly.

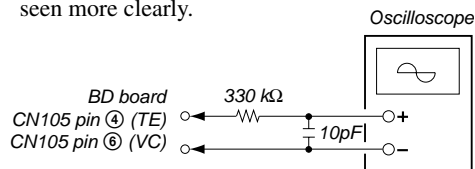

5-6-7. Focus Bias Check

Change the focus bias and check the focus tolerance amount.

Checking Procedure :

- Load a continuously recorded test disc (MDW-74/GA-1). (Refer to “5-5. Using the Continuously Recorded Disc”.)
- Rotate the **[AMS]** knob and display “CPLAY1MODE” (C34).
- Press the **[I/⏻]** button and display “CPLAY1 MID”.
- Press the **[■/▲]** button when “C = [] AD = []” is displayed.
- Rotate the **[AMS]** knob and display “FBIAS CHECK” (C16).
- Press the **[I/⏻]** button and display “ []/[] c = []”.
The first four digits indicate the C1 error rate, the two digits after [/] indicate ADER, and the 2 digits after [c =] indicate the focus bias value.
Check that the C1 error is below 20 and ADER is below 2.
- Press the **[I/⏻]** button and display “ []/[] b = []”.
Check that the C1 error is below 100 and ADER is below 2.
- Press the **[I/⏻]** button and display “ []/[] a = []”.
Check that the C1 error is below 100 and ADER is below 2.
- Press the **[■/▲]** button, next press the **[⏏]** button, and remove the test disc.

5-6-8. C PLAY Check

MO Error Rate Check

Checking Procedure :

- Load a continuously recorded test disc (MDW-74/GA-1). (Refer to “5-5. Using the Continuously Recorded Disc”.)
- Rotate the **[AMS]** knob and display “CPLAY1MODE” (C34).
- Press the **[I/⏻]** button and display “CPLAY1 MID”.
- The display changes to “C = [] AD = []”.
- If the C1 error rate is below 20, check that ADER is 00.
- Press the **[■/▲]** button, stop playback, press the **[■/▲ “PGM”]** button, and test disc.

CD Error Rate Check

Checking Procedure :

- Load a check disc (MD) TDYS-1.
- Rotate the **[AMS]** knob and display “CPLAY1MODE” (C34).
- Press the **[I/⏻]** button twice and display “CPLAY1 MID”.
- The display changes to “C = [] AD = []”.
- Check that the C1 error rate is below 20.
- Press the **[■/▲]** button, stop playback, press the **[■/▲ “PGM”]** button, and the test disc.

5-6-9. Self-Recording/playback Check

Prepare a continuous recording disc using the unit to be repaired and check the error rate.

Checking Procedure :

- Insert a recordable test disc (MDW-74/GA-1) into the unit.
- Rotate the **[AMS]** knob to display “CREC 1MODE” (C35).
- Press the **[I/⏻]** button to display the “CREC1 MID”.
- When recording starts, “**REC**” is displayed, this becomes “CREC1 (@@@@)” (@@@@ is the address), and recording starts.
- About 1 minute later, press the **[■/▲]** button to stop continuous recording.
- Rotate the **[AMS]** knob to display “CPLAY 1MODE” (C34).
- Press the **[I/⏻]** button to display “CPLAY1 MID”.
- “C = [] AD = []” will be displayed.
- Check that the C1 error becomes below 20 and the AD error below 2.
- Press the **[■/▲]** button to stop playback, and press the **[■/▲ “PGM”]** button and remove the disc.

5-7. INITIAL SETTING OF ADJUSTMENT VALUE

Note:

Mode which sets the adjustment results recorded in the non-volatile memory to the initial setting value. However the results of the temperature compensation offset adjustment will not change to the initial setting value.

If initial setting is performed, perform all adjustments again excluding the temperature compensation offset adjustment.

For details of the initial setting, refer to “5-4. Precautions for Adjustments” and execute the initial setting before the adjustment as required.

Setting Procedure :

1. Rotate the [AMS] knob to display “ADJ CLEAR” (C28).
2. Press the [I/O] button. “Complete!” will be displayed momentarily and initial setting will be executed, after which “ADJ CLEAR” (C28) will be displayed.

5-8. RECORDING AND DISPLAYING Iop INFORMATION

The Iop (C28) data can be recorded in the non-volatile memory. Iop value on the label of the optical pick-up and Iop value after the adjustment will be recorded. Recording these data eliminates the need to read the label on the optical pick-up.

Recording Procedure :

1. While pressing the [AMS] knob and [▲/▼] button, connect the power plug to the outlet, and release the [AMS] knob and [▲/▼] button.
2. Rotate the [AMS] knob to display “[Service]”, and press the [I/O] button.
3. Rotate the [AMS] knob to display “Iop Write” (C05), and press the [I/O] button.
4. The display becomes Ref=@@.@ (@ is an arbitrary number) and the numbers which can be changed will blink.
5. Input Iop value written on the optical pick-up.
To select the number : Rotate the [AMS] knob
To select the digit : Press the [AMS] knob
6. When the [I/O] button is pressed, the display becomes “Measu=@@.@” (@ is an arbitrary number).
7. As the adjustment results are recorded for the 6 value. Leave it as it is and press the [I/O] button.
8. “Complete! !” will be displayed momentarily. The value will be recorded in the non-volatile memory and the display will become “Iop Write” (C05).

Display Procedure :

1. Rotate the [AMS] knob to display “Iop Read” (C26).
2. “@@.@/###.#” is displayed and the recorded contents are displayed.
@@.@ indicates Iop value labeled on the pick-up.
###.# indicates Iop value after adjustment
3. To end, press the [▲/▼] button to display “Iop Read” (C26).

5-9. TEMPERATURE COMPENSATION OFFSET ADJUSTMENT

Save the temperature data at that time in the non-volatile memory as 25 °C reference data.

Note :

1. Usually, do not perform this adjustment.
2. Perform this adjustment in an ambient temperature of 22 °C to 28 °C. Perform it immediately after the power is turned on when the internal temperature of the unit is the same as the ambient temperature of 22 °C to 28 °C.
3. When D101 has been replaced, perform this adjustment after the temperature of this part has become the ambient temperature.

Adjusting Procedure :

1. Rotate the [AMS] knob and display “TEMP ADJUST” (C03).
2. Press the [I/O] button and select the “TEMP ADJUST” (C03) mode.
3. “TEMP = [] [OK]” and the current temperature data will be displayed.
4. To save the data, press the [I/O] button.
When not saving the data, press the [▲/▼] button.
5. When the [I/O] button is pressed, “TEMP = [] SAVE” will be displayed and turned back to “TEMP ADJUST” (C03) display then. When the [▲/▼] button is pressed, “TEMP ADJUST” (C03) will be displayed immediately.

Specified Value :

The “TEMP = []” should be within “E0 - EF”, “F0 - FF”, “00 - 0F”, “10 - 1F” and “20 - 2F”.

5-10. LASER POWER ADJUSTMENT

Check Iop value of the optical pick-up before adjustments. (Refer to 5-8. Recording and Displaying Iop Information.)

Connection :

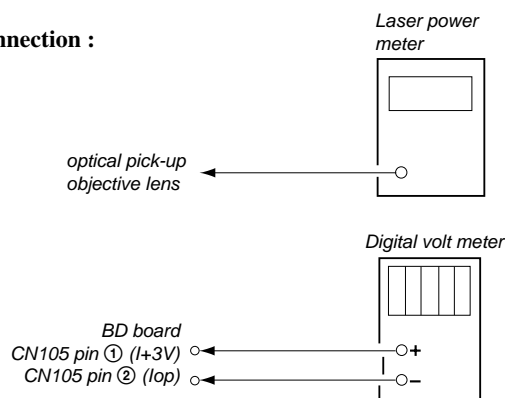

Adjusting Procedure :

1. Set the laser power meter on the objective lens of the optical pick-up.
Connect the digital volt meter to CN105 pin ① (I+3V) and CN105 pin ② (Iop).
2. Rotate the [AMS] knob and display “LDPWR ADJUST” (C13).
(Laser power : For adjustment)
3. Press the [I/O] button once and display “LD 0.9 mW \$ []”.
4. Rotate the [AMS] knob so that the reading of the laser power meter becomes 0.85 to 0.91 mW. Press the [I/O] button after setting the range knob of the laser power meter, and save the adjustment results. (“LD SAVE \$ []” will be displayed for a moment.)
5. Then “LD 7.0 mW \$ []” will be displayed.
6. Rotate the [AMS] knob so that the reading of the laser power meter becomes 6.9 to 7.1 mW, press the [I/O] button and save it.

Note : Do not perform the emission with 7.0 mW more than 15 seconds continuously.

- Then, rotate the **[AMS]** knob and display “LDPWR CHECK” (C13).
- Press the **[I/O]** button once and display “LD 0.9 mW \$ []”. Check that the reading of the laser power meter become 0.85 to 0.91 mW.
- Press the **[I/O]** button once more and display “LD 7.0 mW \$ []”. Check that the reading the laser power meter and digital volt meter satisfy the specified value.
Note down the digital voltmeter reading value.

Specified Value :

Laser power meter reading : 7.0 ± 0.2 mW

Digital voltmeter reading : Optical pick-up displayed value $\pm 10\%$

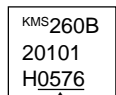

(For details of the method for checking this value, refer to “5-8. Recording and Displaying Iop Information”.)

Iop = 57.6 mA in this case

Iop (mA) = Digital voltmeter reading (mV)/1 (Ω)

(Optical pick-up label)

- Press the **[I/O]** button and display “LDPWR CHECK” (C13) and stop the laser emission.
(The **[I/O]** button is effective at all times to stop the laser emission.)
- Rotate the **[AMS]** knob to display “Iop Write” (C05).
- Press the **[I/O]** button. When the display becomes Ref=@@@@ (@ is an arbitrary number), press the **[I/O]** button to display “Measu=@@@@” (@ is an arbitrary number).
- The numbers which can be changed will blink. Input Iop value noted down at step 9.
To select the number : Rotate the **[AMS]** knob.
To select the digit : Press the **[AMS]** knob
- When the **[I/O]** button is pressed, “Complete! ” will be displayed momentarily. The value will be recorded in the non-volatile memory and the display will become “Iop Write” (C05).

Note 1: After step 4, each time the **[I/O]** button is pressed, the display will be switched between “LD 0.7 mW \$ []”, “LD 6.2 mW \$ []”, and “LD Wp ホセイ \$ []”. Nothing needs to be performed here.

5-11. Iop NV SAVE

Write the reference values in the nonvolatile memory to perform “Iop Compare”. As this involves rewriting the reference values, do not perform this procedure except when adjusting the laser power during replacement of the optical pick-up and when replacing the IC102. Otherwise the optical pick-up check may deteriorate.

Note: Perform this function with the optical pick-up set at room temperature.

Procedure

- Rotate the **[AMS]** knob to display “Iop NV Save” (C06).
- Press the **[I/O]** button and display “Iop [stop]”.
- After the display changes to “Iop =xxsave?”, press the **[I/O]** button.
- After “Complete!” is displayed momentarily, the display changes to “Iop 7.0 mW”.
- After the display changes to “Iop=yysave?”, press the **[I/O]** button.
- When “Complete!” is displayed, it means that Iop NV saving has been completed.

5-12. TRAVERSE ADJUSTMENT

Connection :

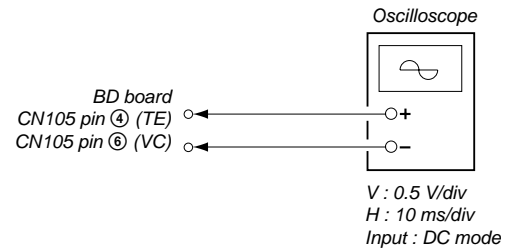

Adjusting Procedure :

- Connect an oscilloscope to CN105 pin ④ (TE) and CN105 pin ⑥ (VC) of the BD board.
- Load a test disc (MDW-74/GA-1). (Refer to Note 1.)
- Rotate the **[AMS]** knob and display “EF MO ADJUST” (C07).
- Press the **[I/O]** button and display “EFB = [] MO-R”.
(Laser power READ power/Focus servo ON/tracking servo OFF/spindle (S) servo ON)
- Rotate the AMS knob so that the waveform of the oscilloscope becomes the specified value.
(When the **[AMS]** knob is rotated, the [] of “EFB= []” changes and the waveform changes.) In this adjustment, waveform varies at intervals of approx. 2%. Adjust the waveform so that the specified value is satisfied as much as possible.
(Read power traverse adjustment)

(Traverse Waveform)

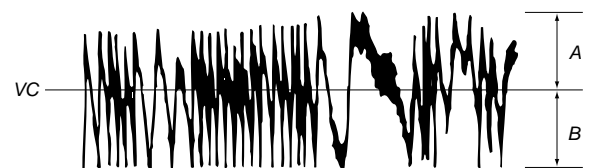

Specification A = B

- Press the **[I/O]** button and save the result of adjustment to the non-volatile memory (“EFB = [] SAVE” will be displayed for a moment. Then “EFB = [] MO-W” will be displayed).
- Rotate the **[AMS]** knob so that the waveform of the oscilloscope becomes the specified value.
(When the **[AMS]** knob is rotated, the [] of “EFB= [] MO-W” changes and the waveform changes.) In this adjustment, waveform varies at intervals of approx. 2%. Adjust the waveform so that the specified value is satisfied as much as possible.
(Write power traverse adjustment)

(Traverse Waveform)

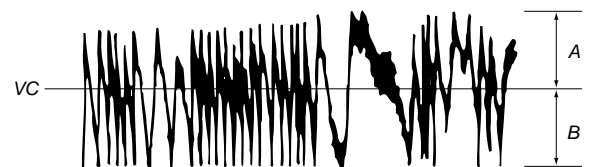

Specification A = B

- Press the **[I/O]** button, and save the adjustment results in the non-volatile memory. (“EFB = [] SAVE” will be displayed for a moment.)
- “EFB = [] MO-P”. will be displayed.
The optical pick-up moves to the pit area automatically and servo is imposed.

10. Rotate the **[AMS]** knob until the waveform of the oscilloscope moves closer to the specified value.
In this adjustment, waveform varies at intervals of approx. 2%.
Adjust the waveform so that the specified value is satisfied as much as possible.

(Traverse Waveform)

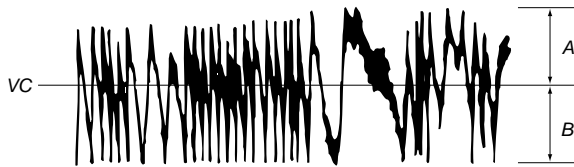

Specification $A = B$

11. Press the **[I/⏻]** button, and save the adjustment results in the non-volatile memory. (“EFB = **[]** SAVE” will be displayed for a moment.)
Next “EF MO ADJUS (C07)” is displayed. The disc stops rotating automatically.
12. Press the **[■/▲]** “PGM” button and remove the disc.
13. Load the check disc (MD) TDYS-1.
14. Rotate **[AMS]** knob and display “EF CD ADJUS” (C08).
15. Press the **[I/⏻]** button and display “EFB = **[]** CD”. Servo is imposed automatically.
16. Rotate the **[AMS]** knob so that the waveform of the oscilloscope moves closer to the specified value.
In this adjustment, waveform varies at intervals of approx. 2%.
Adjust the waveform so that the specified value is satisfied as much as possible.

(Traverse Waveform)

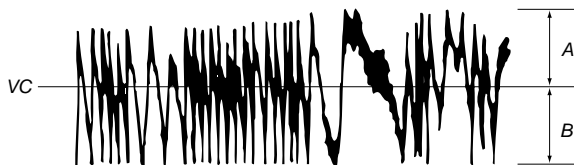

Specification $A = B$

17. Press the **[I/⏻]** button, display “EFB = **[]** SAVE” for a moment and save the adjustment results in the non-volatile memory. Next “EF CD ADJUST” (C08) will be displayed.
18. Press the **[■/▲]** “PGM” button and remove the check disc (MD) TDYS-1.

Note 1 : MO reading data will be erased during if a recorded disc is used in this adjustment.

Note 2 : If the traverse waveform is not clear, connect the oscilloscope as shown in the following figure so that it can be seen more clearly.

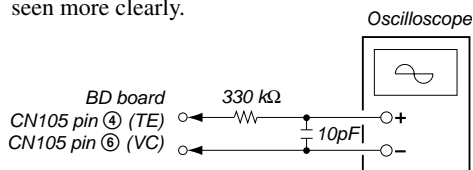

5-13. FOCUS BIAS ADJUSTMENT

Adjusting Procedure :

1. Load a test disk (MDW-74/GA-1).
2. Rotate the **[AMS]** knob and display “CPLAY1MODE” (C34).
3. Press the **[I/⏻]** button and display “CPLAY1 MID”.
4. Press the **[■/▲]** button when “C = **[]** AD = **[]**” is displayed.
5. Rotate the **[AMS]** knob and display “FBIAS ADJUST” (C09).
6. Press the **[I/⏻]** button and display “**[]** a = **[]** T”.
The first four digits indicate the C error rate, the two digits after [/] indicate ADER, and the 2 digits after [a =] indicate the focus bias value.
7. Rotate the **[AMS]** knob in the clockwise direction and find the focus bias value at which the C error rate becomes 200 (Refer to Note 2).
8. Press the **[I/⏻]** button and display “**[]** b = **[]** T”.
9. Rotate the **[AMS]** knob in the counterclockwise direction and find the focus bias value at which the C error rate becomes 200.
10. Press the **[I/⏻]** button and display “**[]** c = **[]** T”.
11. Check that the C error rate is below 20 and ADER is 00. Then press the **[I/⏻]** button.
12. If the “(**[]** ” in “**[]** - **[]** - **[]** (**[]** ” is above 20, press the **[I/⏻]** button.
If below 20, press the **[■/▲]** button and repeat the adjustment from step 2.
13. Press the **[■/▲]** “PGM” button to remove the test disc.

Note 1 : The relation between the C error and focus bias is as shown in the following figure. Find points a and b in the following figure using the above adjustment. The focal point position c is automatically calculated from points a and b.

Note 2 : As the C error rate changes, perform the adjustment using the average value.

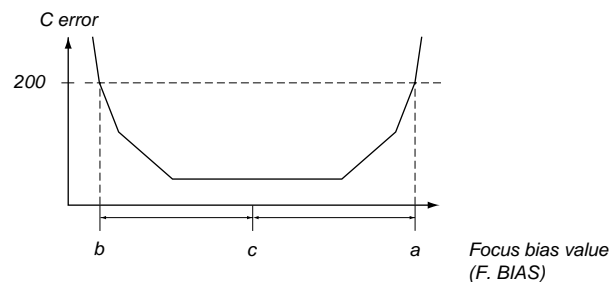

5-14. ERROR RATE CHECK

5-14-1. CD Error Rate Check

Checking Procedure :

1. Load a check disc (MD) TDYS-1.
2. Rotate the [AMS] knob and display "CPLAY1MODE" (C34).
3. Press the [I/⏻] button twice and display "CPLAY1 MID".
4. The display changes to "C = [] AD = []".
5. Check that the C1 error rate is below 20.
6. Press the [■/▲] button, stop playback, press the [■/▲] "PGM" button, and remove the test disc.

5-14-2. MO Error Rate Check

Checking Procedure :

1. Load a continuously recorded test disc (MDW-74/GA-1).
(Refer to "5-5. Using the Continuously Recorded Disc".)
2. Rotate the [AMS] knob and display "CPLAY1MODE" (C34).
3. Press the [I/⏻] button and display "CPLAY1 MID".
4. The display changes to "C = [] AD = []".
5. If the C1 error rate is below 20, check that ADER is 00.
6. Press the [■/▲] button, stop playback, press the [■/▲] "PGM" button, and remove the test disc.

5-15. FOCUS BIAS CHECK

Change the focus bias and check the focus tolerance amount.

Checking Procedure :

1. Load a continuously recorded test disc (MDW-74/GA-1).
(Refer to "5-5. Using the Continuously Recorded Disc".)
2. Rotate the [AMS] knob and display "CPLAY1MODE" (C34).
3. Press the [I/⏻] button twice and display "CPLAY1 MID".
4. Press the [■/▲] button when "C = [] AD = []" is displayed.
5. Rotate the [AMS] knob and display "FBIAS CHECK" (C16).
6. Press the [I/⏻] button and display " []/[] c = []".
The first four digits indicate the C error rate, the two digits after [] indicate ADR, and the 2 digits after [c =] indicate the focus bias value.
Check that the C error is below 20 and ADER is below 2.
7. Press the [I/⏻] button and display " []/[] b = []".
Check that the C error is below 100 and ADER is below 2.
8. Press the [I/⏻] button and display " []/[] a = []".
Check that the C error is below 100 and ADER is below 2.
9. Press the [■/▲] button, next press the [■/▲] "PGM" button, and remove the continuously recorded disc.

Note 1 : If the C error and ADER are above other than the specified value at points a (step 8. in the above) or b (step 7. in the above), the focus bias adjustment may not have been carried out properly. Adjust perform the beginning again.

5-16. AUTO GAIN CONTROL OUTPUT LEVEL ADJUSTMENT

Be sure to perform this adjustment when the optical pick-up is replaced.

If the adjustment results becomes "Adjust NG!", the optical pick-up may be faulty or the servo system circuits may be abnormal.

5-16-1. CD Auto Gain Control Output Level Adjustment

Adjusting Procedure :

1. Insert the check disc (MD) TDYS-1.
2. Rotate the [AMS] knob to display "AG Set (CD)" (C11).
3. When the [I/⏻] button is pressed, the adjustment will be performed automatically.
"Complete! !" will then be displayed momentarily when the value is recorded in the non-volatile memory, after which the display changes to "AG Set (CD)" (C11).
4. Press the [■/▲] "PGM" button to remove the disc.

5-16-2. MO Auto Gain Control Output Level Adjustment

Adjusting Procedure :

1. Insert the reference disc (MDW-74/GA-1) for recording.
2. Rotate the [AMS] knob to display "AG Set (MO)" (C10).
3. When the [I/⏻] button is pressed, the adjustment will be performed automatically.
"Complete! !" will then be displayed momentarily when the value is recorded in the non-volatile memory, after which the display changes to "AG Set (MO)" (C10).
4. Press the [■/▲] "PGM" button to remove the disc.

5-17. ADJUSTING POINTS AND CONNECTING POINTS

[BD BOARD] (SIDE A)

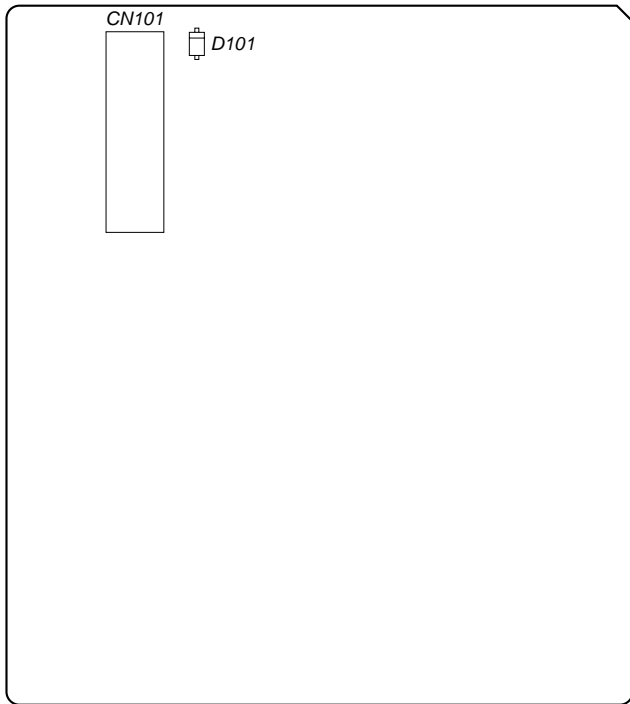

[BD BOARD] (SIDE B)

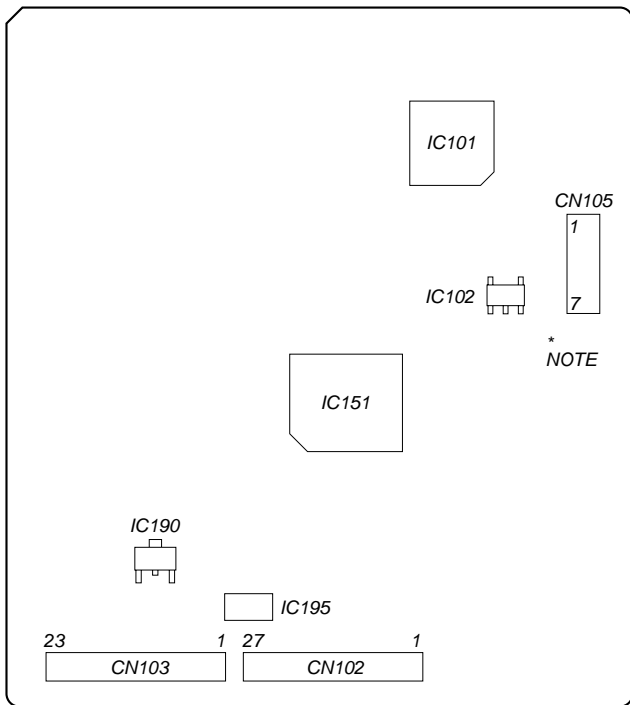



NOTE:It is useful to use the jig. for checking the waveform. (Refer to Servicing Note on page 6.)

SECTION 6 DIAGRAMS

THIS NOTE IS COMMON FOR PRINTED WIRING BOARDS AND SCHEMATIC DIAGRAMS.
(In addition to this, the necessary note is printed in each block.)







For schematic diagrams.

Note:

- All capacitors are in μF unless otherwise noted. pF : μF 50 WV or less are not indicated except for electrolytics and tantalums.
- All resistors are in Ω and $1/4\text{ W}$ or less unless otherwise specified.
- Δ : internal component.
-  : nonflammable resistor.
-  : fusible resistor.
-  : panel designation.



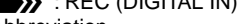

Note:
The components identified by mark Δ or dotted line with mark Δ are critical for safety. Replace only with part number specified.

Note:
Les composants identifiés par une marque Δ sont critiques pour la sécurité. Ne les remplacer que par une pièce portant le numéro spécifié.

-  : B+ Line.
-  : B- Line.
-  : adjustment for repair.
- Voltages and waveforms are dc with respect to ground under no-signal (detuned) conditions.
- Voltages are taken with a VOM (Input impedance 10 M Ω). Voltage variations may be noted due to normal production tolerances.
- Waveforms are taken with an oscilloscope. Voltage variations may be noted due to normal production tolerances.
- Circled numbers refer to waveforms.
- Signal path.
 -  : PB
 -  : REC
 -  : PB (DIGITAL OUT)
 -  : REC (DIGITAL IN)
- Abbreviation
 - CND : Canadian model
 - SP : Singapore model
 - MY : Malaysia model

For printed wiring boards.

Note:

-  : parts extracted from the component side.
-  : parts extracted from the conductor side.
-  : Through hole.
-  : Pattern from the side which enables seeing. (The other layers' patterns are not indicated.)

Caution:
Pattern face side: Parts on the pattern face side seen from the (Side B) pattern face are indicated.
Parts face side: Parts on the parts face side seen from the (Side A) parts face are indicated.

• Indication of transistor

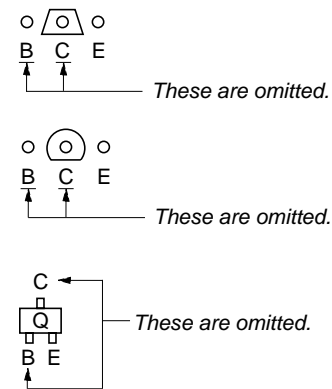

• WAVEFORMS

– BD Board –

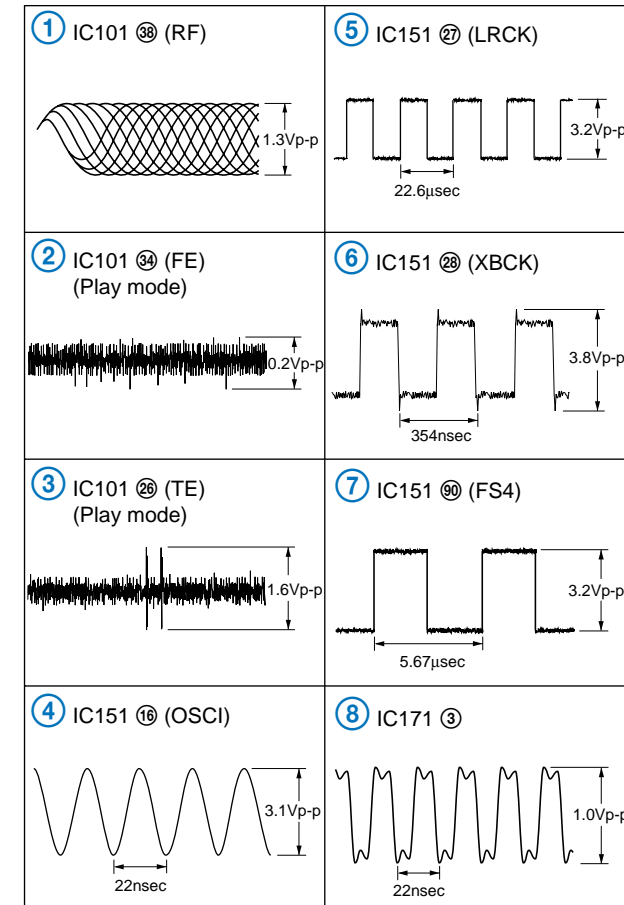

– MAIN Board –

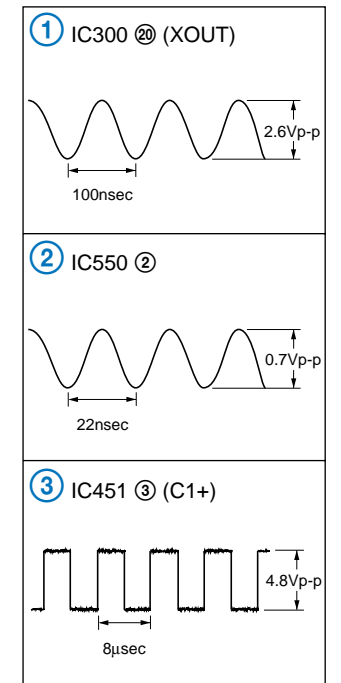

6-1. BLOCK DIAGRAMS - BD SECTION -

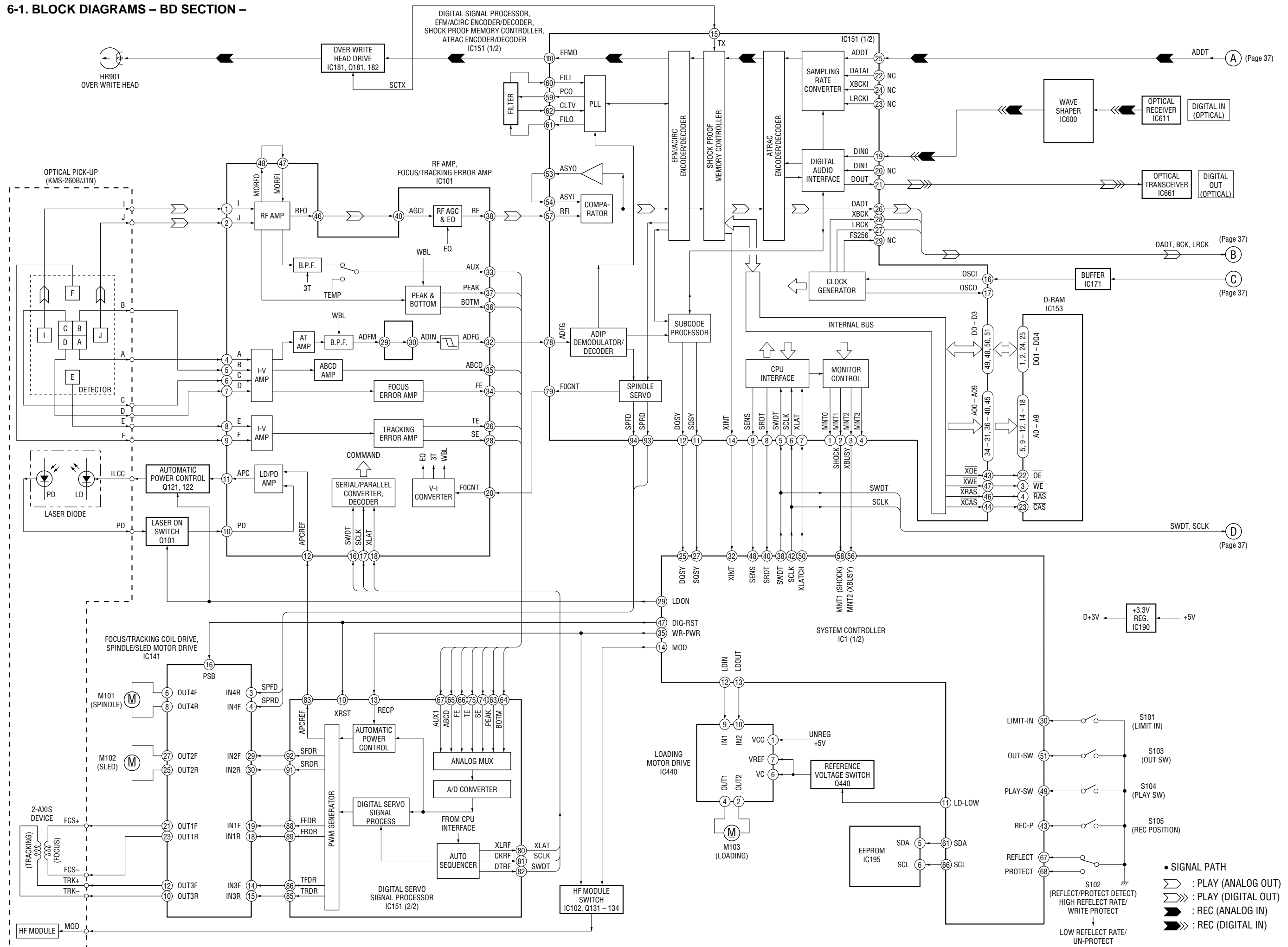

- MAIN SECTION -

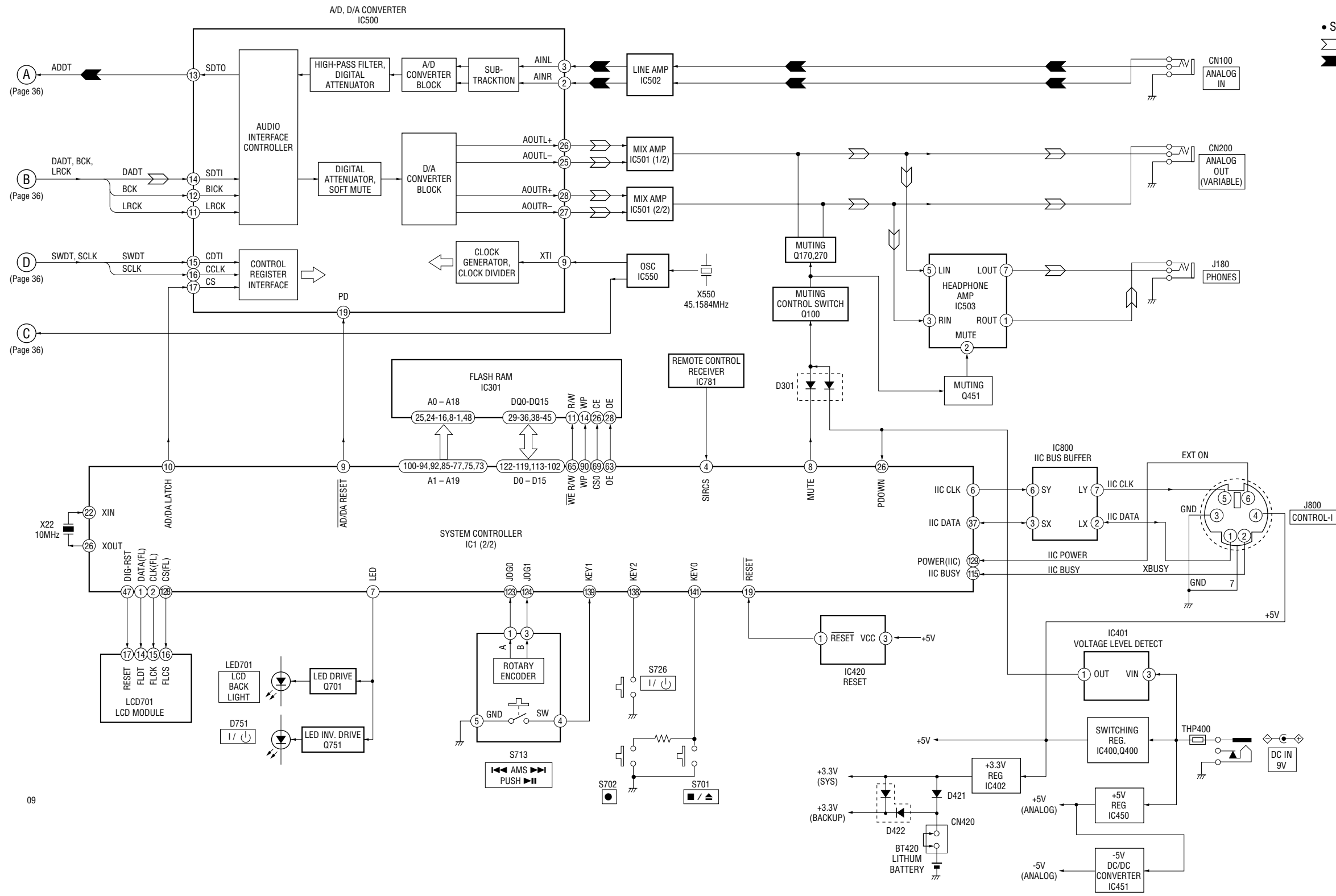

• SIGNAL PATH
 ◁ ▷ : PLAY (ANALOG OUT)
 ◁ ▷ : REC (ANALOG IN)

09

6-2. PRINTED WIRING BOARD – BD SECTION –

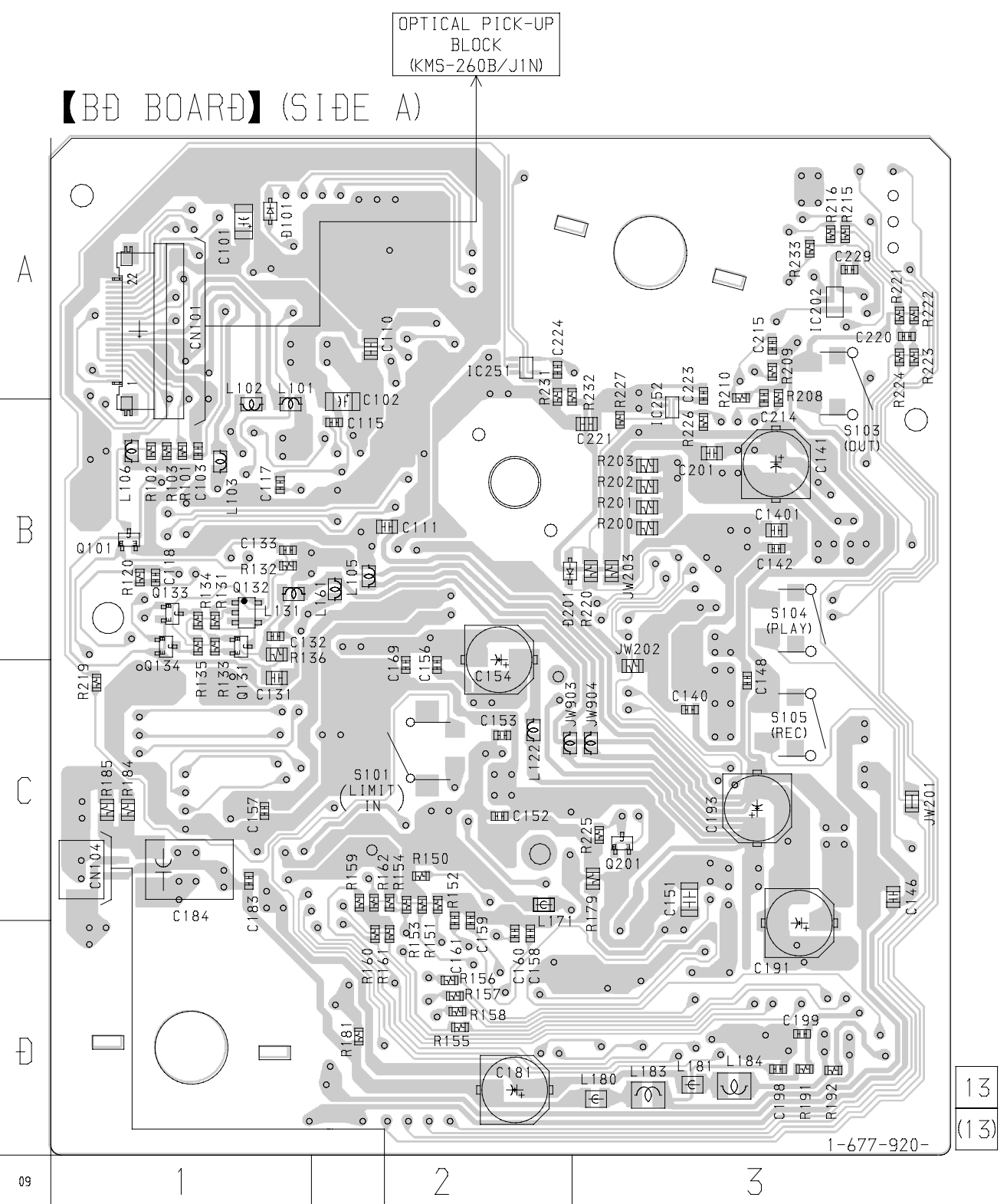

• Semiconductor Location

Ref. No.	Location
D101	A-4
Q101	B-1
Q131	C-1
Q132	B-1
Q133	B-1
Q134	C-1

HR901
OVER
WRITE HEAD

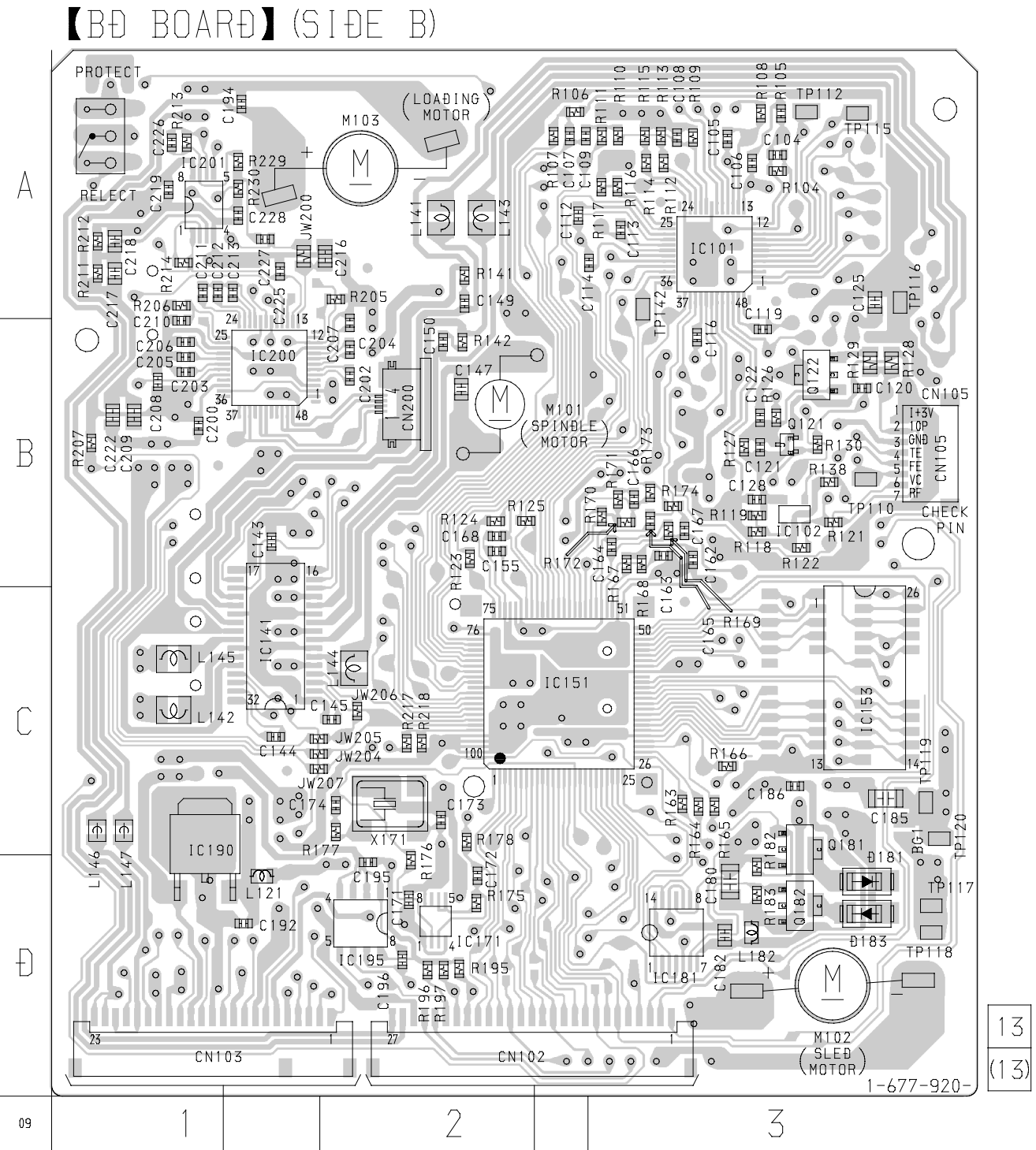

• Semiconductor Location

Ref. No.	Location	Ref. No.	Location
D181	D-3	IC181	D-3
D183	D-3	IC190	D-1
		IC195	D-2
IC101	A-3	Q121	B-3
IC102	B-3	Q122	B-3
IC141	C-1	Q181	D-3
IC151	C-2	Q182	D-3
IC153	C-3		
IC171	D-2		

There are a few cases that the part isn't mounted in model is printed on diagram.

6-3. SCHEMATIC DIAGRAM – BD SECTION (1/2) – • See page 35 for Waveforms. • See page 46 for IC Block Diagrams. • See page 49 for IC Pin Functions. • See page 38 for Printed Wiring Board.

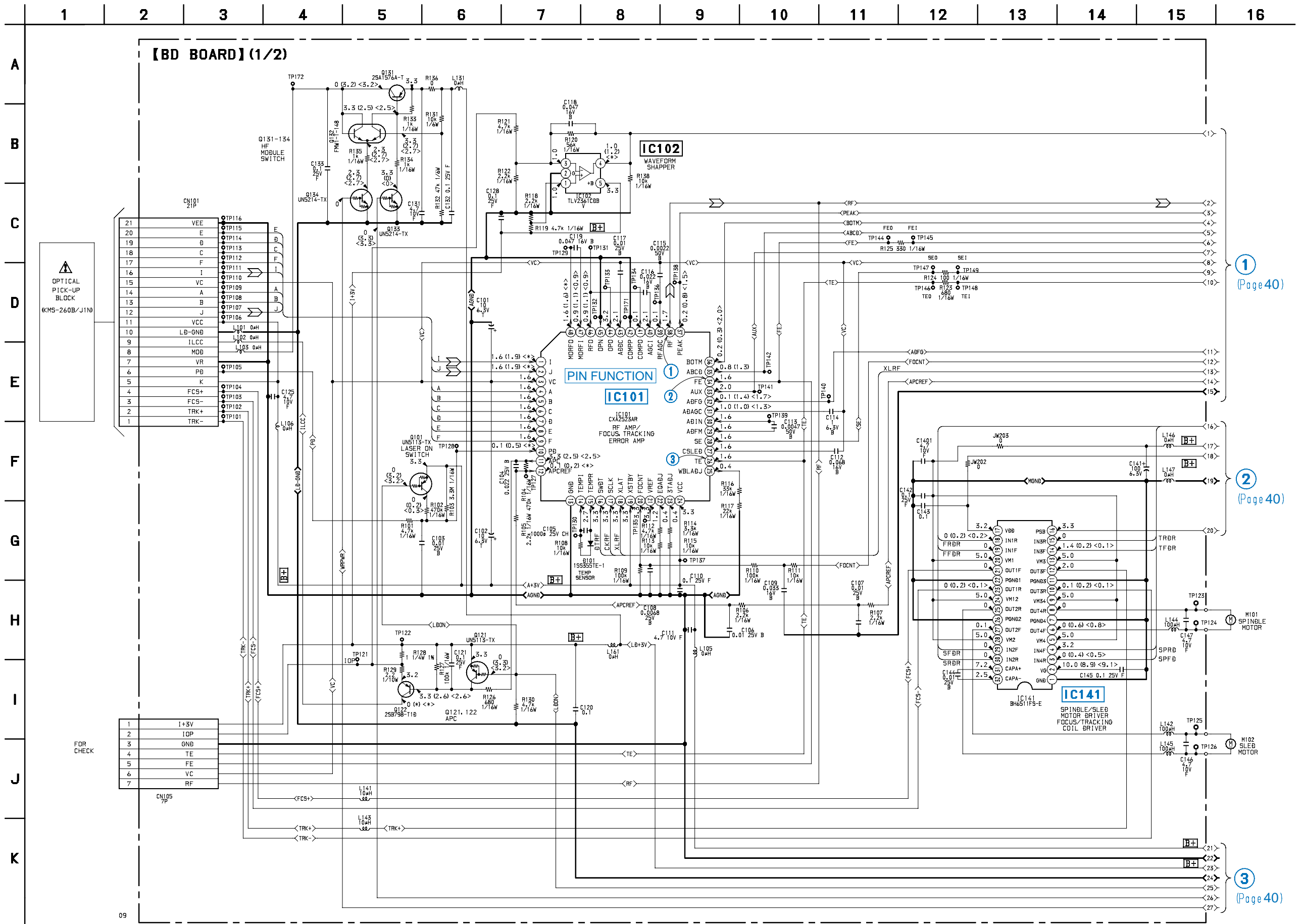

Note: The components identified by mark **▲** or dotted line with mark **▲** are critical for safety. Replace only with part number specified.

Note: Les composants identifiés par une marque **▲** sont critiques pour la sécurité. Ne les remplacer que par une pièce portant le numéro spécifié.

NOTE
• Voltages and waveforms are dc with respect to ground under no-signal conditions.

no mark: STOP
(): PLAY
< >: REC
* : can not be measured.

6-4. SCHEMATIC DIAGRAM – BD SECTION (2/2) – • See page 35 for Waveforms. • See page 46 for IC Block Diagrams. • See page 50 for IC Pin Functions. • See page 38 for Printed Wiring Board.

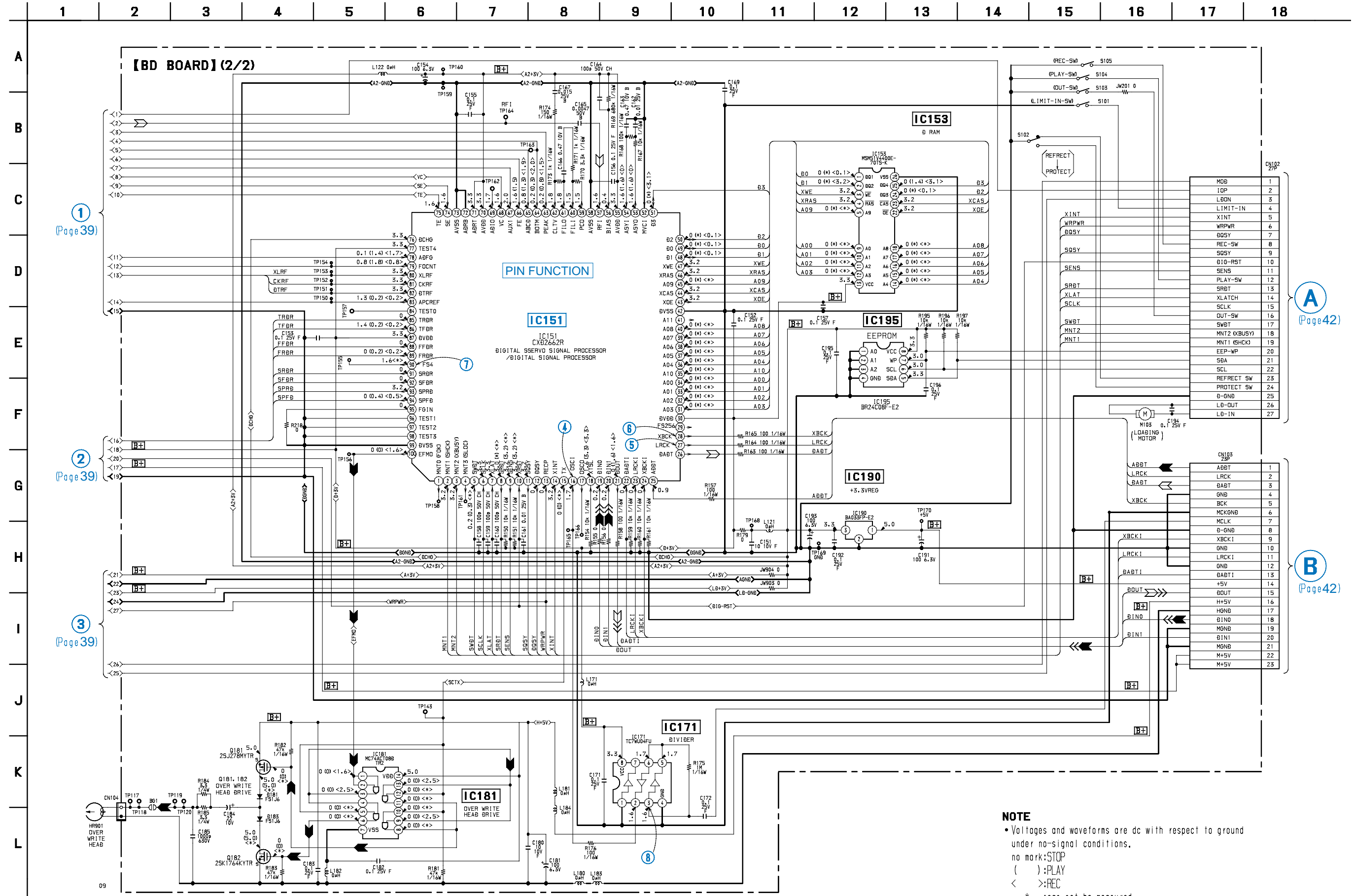

① (Page 39)

② (Page 39)

③ (Page 39)

A (Page 42)

B (Page 42)

NOTE
• Voltages and waveforms are dc with respect to ground under no-signal conditions.
no mark: STOP
(): PLAY
< >: REC
* : can not be measured.

6-5. PRINTED WIRING BOARD – MAIN SECTION –

• MAIN and PANEL boards are lead free soldered (contains no lead).

【MAIN BOARD】(SIDE B)

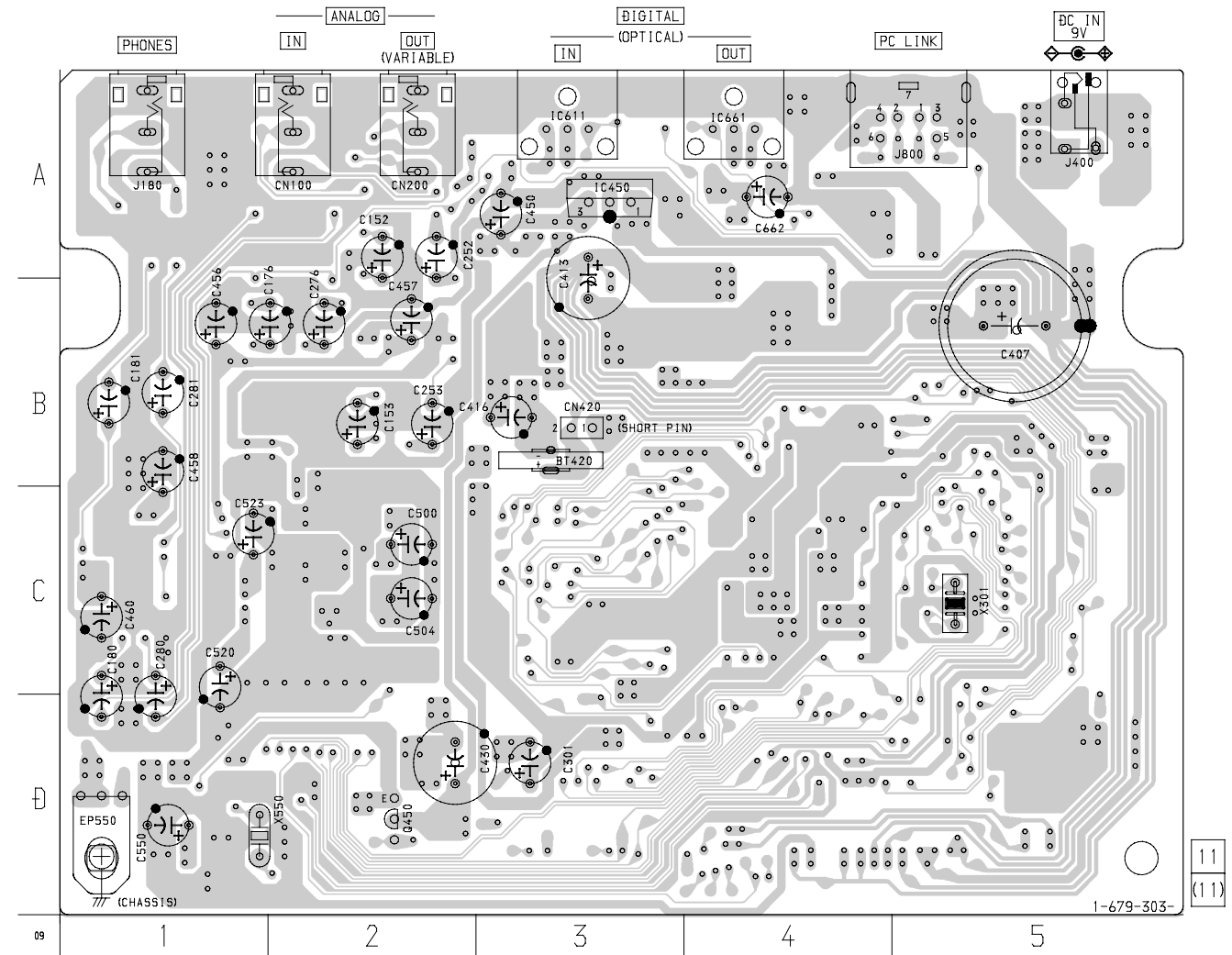
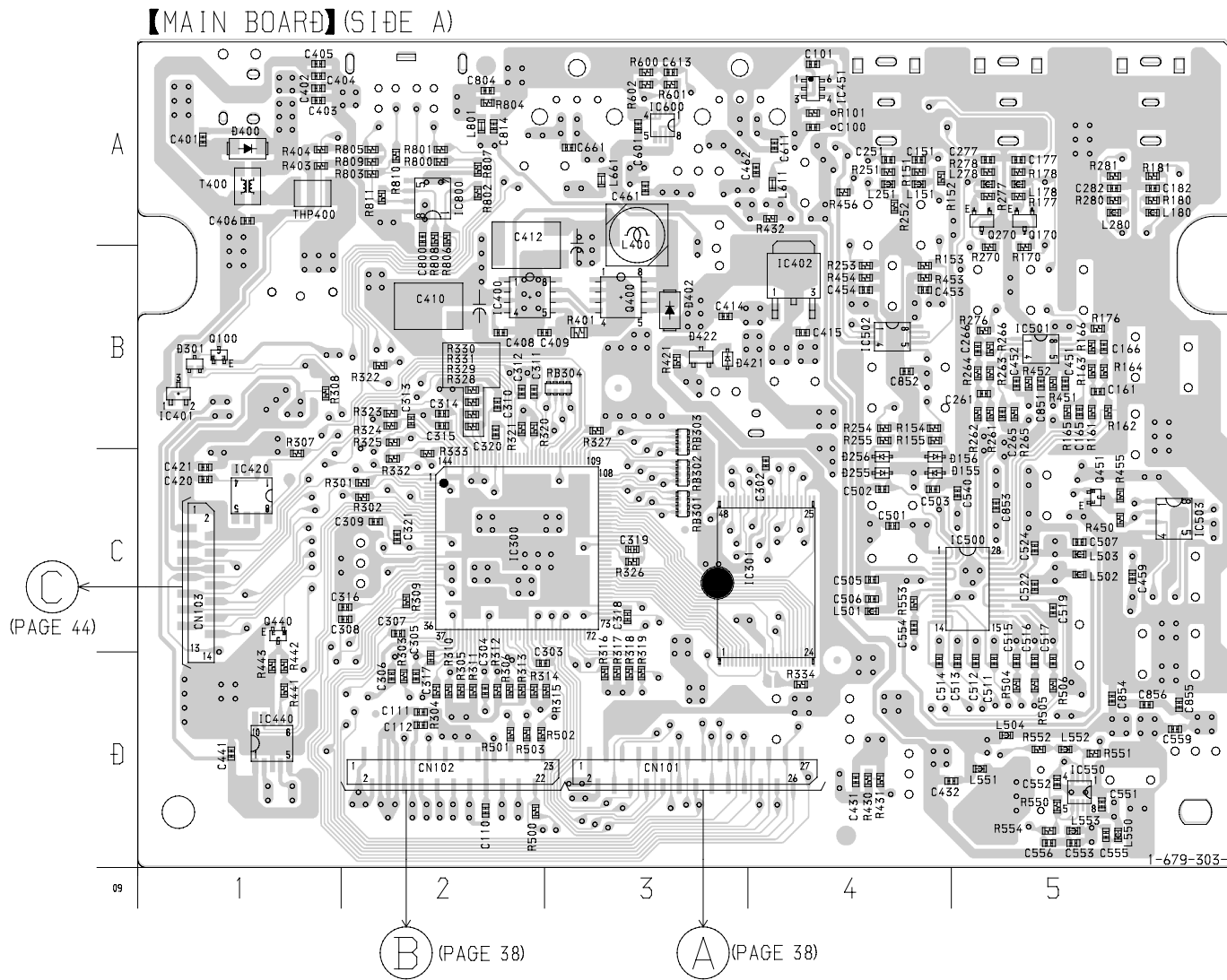

• Semiconductor Location

Ref. No.	Location	Ref. No.	Location
D155	C-4	IC440	B-1
D156	C-4	IC451	A-4
D255	C-4	IC500	C-5
D256	C-4	IC501	B-5
D301	B-1	IC502	B-4
D400	A-1	IC503	C-5
D402	B-3	IC550	D-5
D421	B-3	IC600	A-3
D422	B-3	IC800	A-2
IC300	C-2	Q100	B-1
IC301	C-4	Q170	B-5
IC400	B-2	Q270	B-5
IC401	B-1	Q400	B-3
IC402	B-4	Q440	C-1
IC420	C-1	Q451	C-5

• Semiconductor Location

Ref. No.	Location
IC450	A-3
IC611	A-3
IC661	A-4
Q450	D-2

There are a few cases that the part isn't mounted in model is printed on diagram.

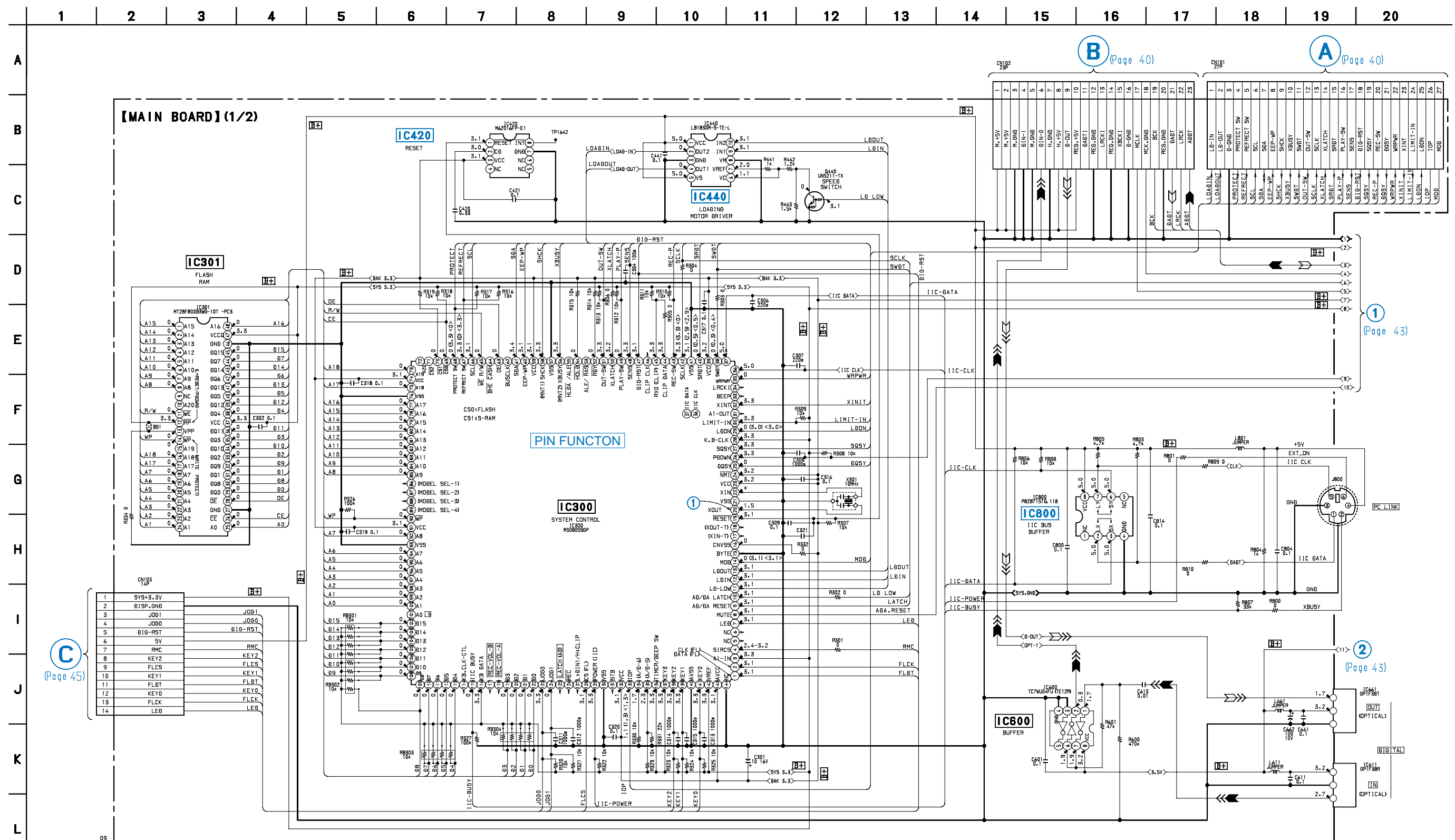

NOTE

- Voltages and waveforms are dc with respect to ground () :PLAY under no-signal conditions. < >:REC
- * :can not be measured.

6-7. SCHEMATIC DIAGRAM – MAIN SECTION (2/2) – • See page 35 for Waveforms. • See page 41 for Printed Wiring Board. • See page 47 for IC Block Diagrams.

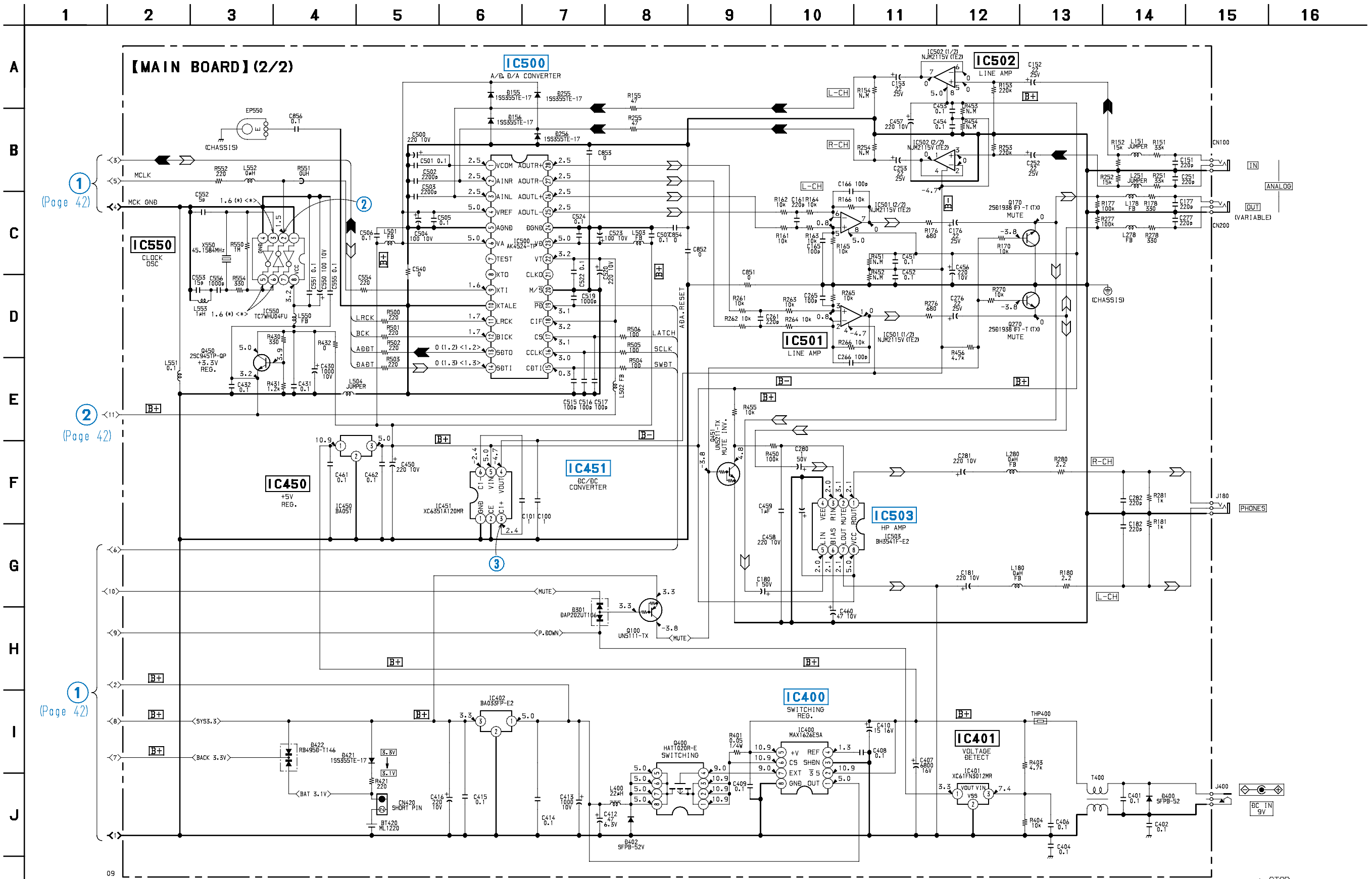

1 (Page 42)

2 (Page 42)

1 (Page 42)

NOTE
 • Voltages and waveforms are dc with respect to ground under no-signal conditions.
 no mark:STOP
 ():PLAY
 < >:REC
 * :can not be measured.

6-8. PRINTED WIRING BOARD – PANEL SECTION –

• MAIN and PANEL boards are lead free soldered (contains no lead).

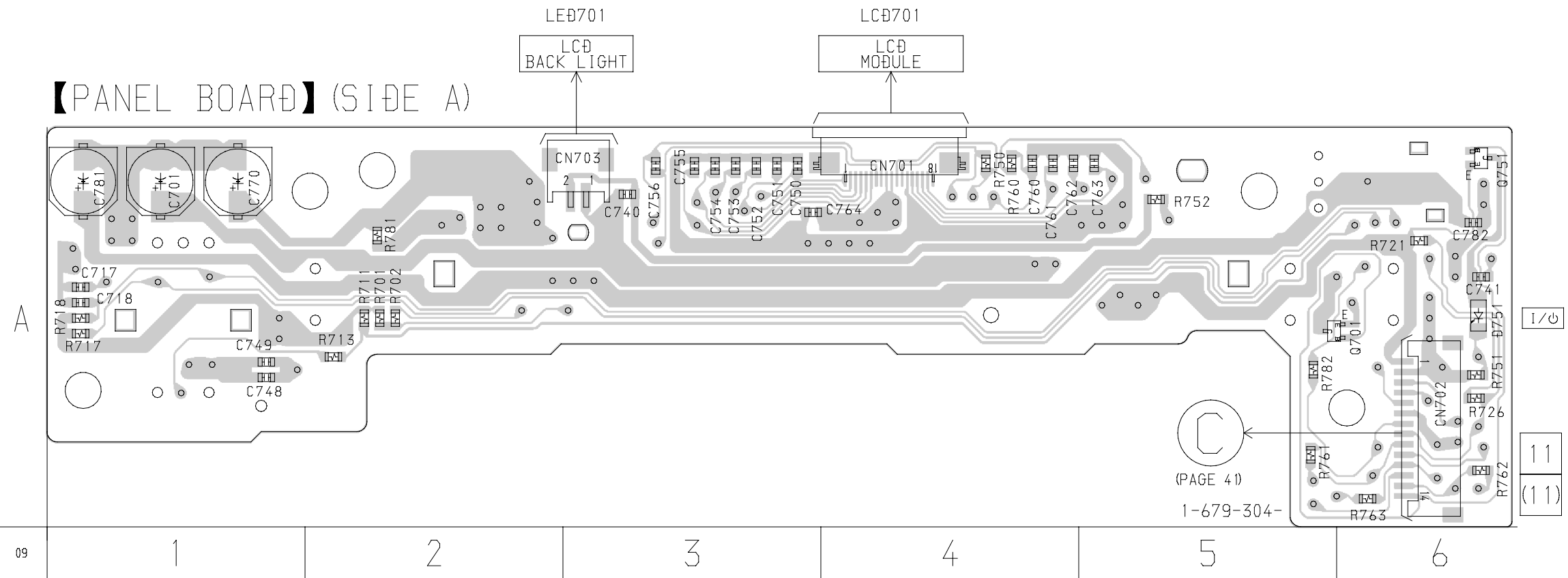

• Semiconductor Location

Ref. No.	Location
D751	A-6
Q701	A-6
Q751	A-6

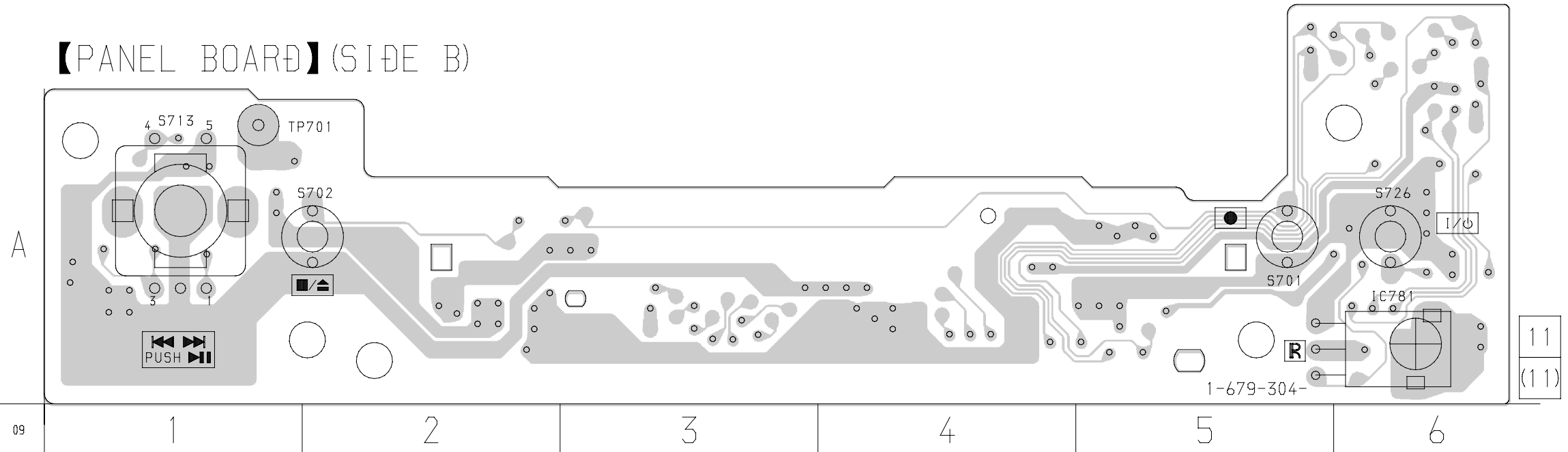

• Semiconductor Location

Ref. No.	Location
IC781	A-6

There are a few cases that the part isn't mounted in model is printed on diagram.

6-9. SCHEMATIC DIAGRAM – PANEL SECTION – • See page 35 for Waveforms.

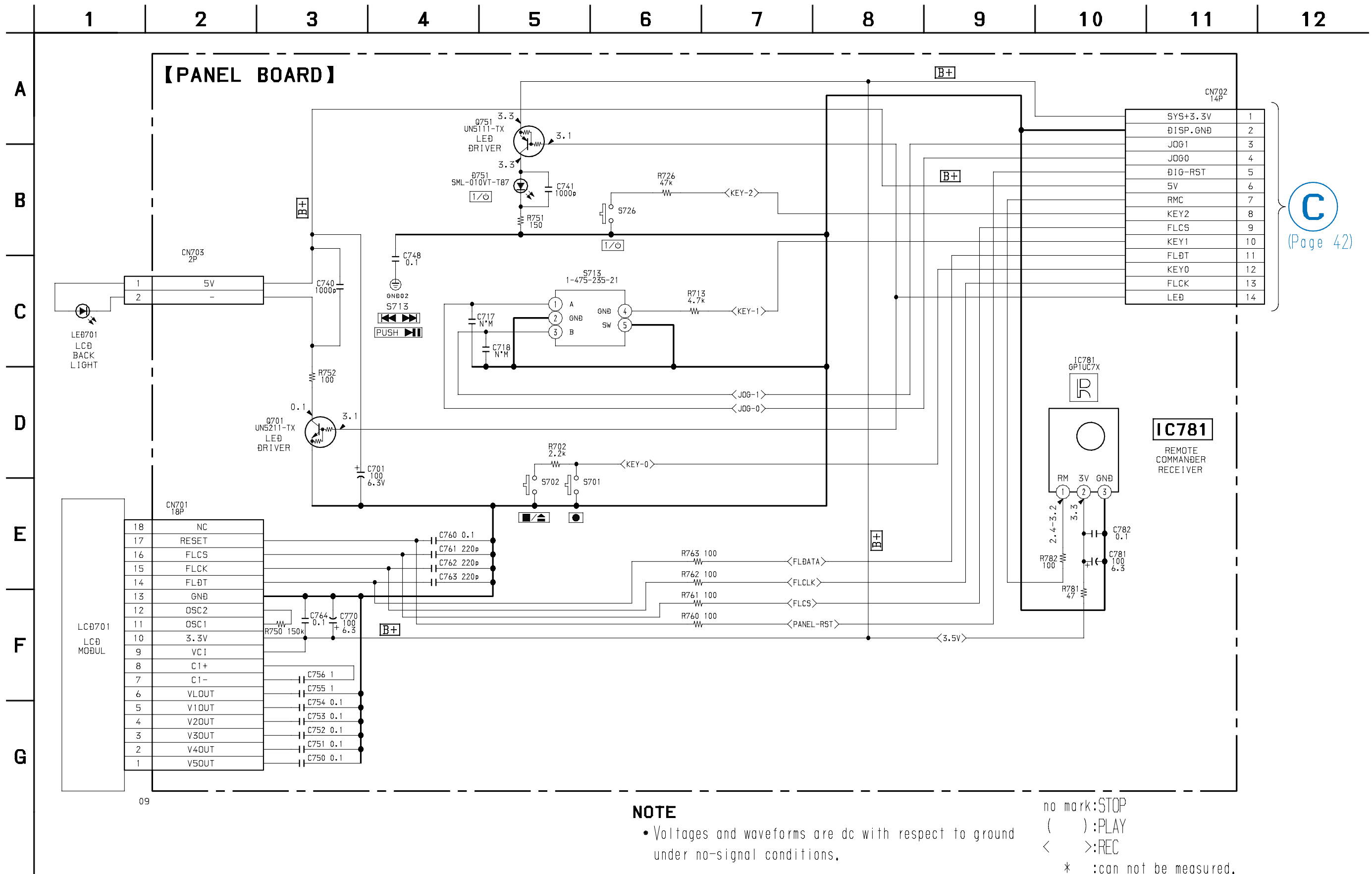

C
(Page 42)

NOTE

• Voltages and waveforms are dc with respect to ground under no-signal conditions.

no mark: STOP
 (): PLAY
 < >: REC
 * : can not be measured.

IC400 MAX1626ESA-TE2 (MAIN BOARD)

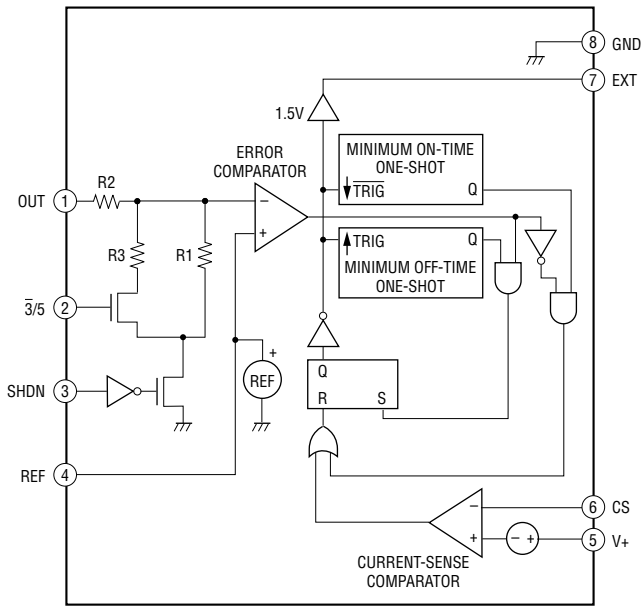

IC451 XC6351A120MR (MAIN BOARD)

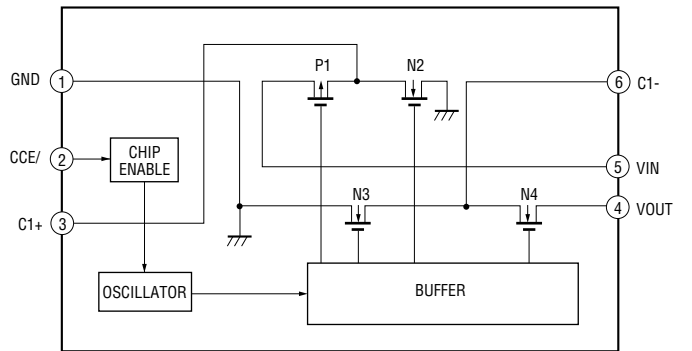

IC500 AK4524 (MAIN BOARD)

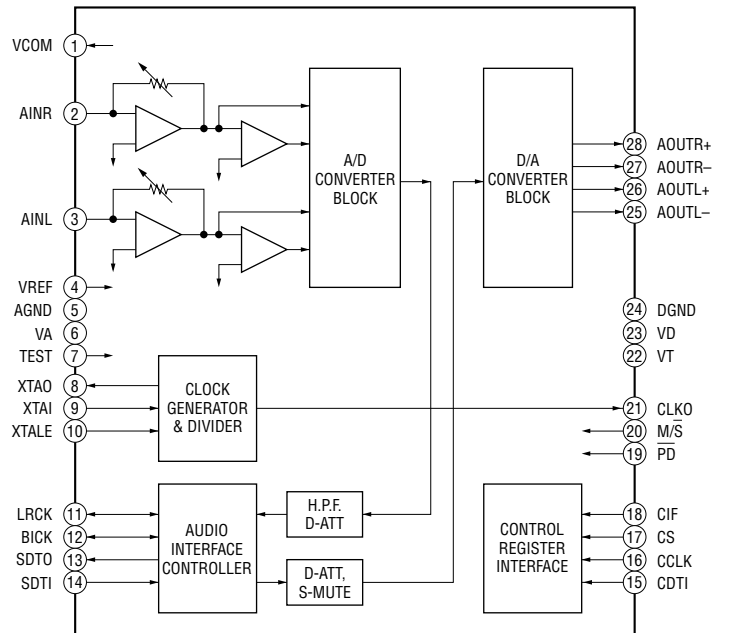

IC440 LB1830M-S-TE-L (MAIN BOARD)

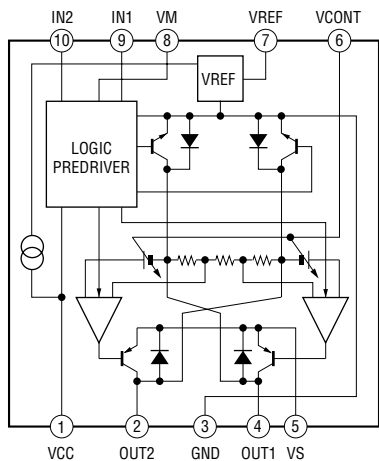

IC420 M62016FP-E1 (MAIN BOARD)

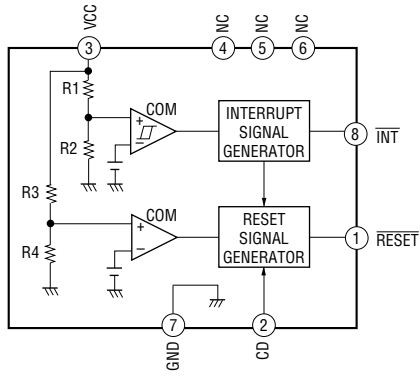

IC503 BH3541F-E2 (MAIN BOARD)

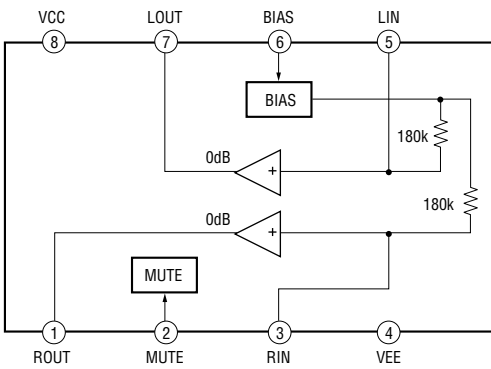

IC800 P82B715TD.118 (MAIN BOARD)

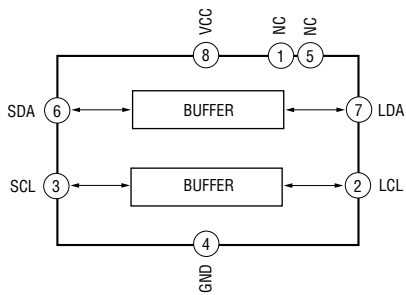

6-11. IC PIN FUNCTIONS

• IC101 CXA2523AR RF Amplifier (BD BOARD)

Pin No.	Pin Name	I/O	Function
1	I	I	I-V converted RF signal I input
2	J	I	I-V converted RF signal J input
3	VC	O	Middle point voltage (+1.5V) generation output
4 to 9	A to F	I	Signal input from the optical pick-up detector
10	PD	I	Light amount monitor input
11	APC	O	Laser APC output
12	APCREF	I	Reference voltage input for setting laser power
13	GND	—	Ground
14	TEMPI	I	Temperature sensor connection
15	TEMPR	O	Reference voltage output for the temperature sensor
16	SWDT	I	Serial data input from the CXD2662R
17	SCLK	I	Serial clock input from the CXD2662R
18	XLAT	I	Latch signal input from the CXD2662R “L”: Latch
19	XSTBY	I	Stand by signal input “L”: Stand by
20	FOCNT	I	Center frequency control voltage input of BPF22, BPF3T, EQ from the CXD2662R
21	VREF	O	Reference voltage output (Not used)
22	EQADJ	I/O	Center frequency setting pin for the internal circuit EQ
23	3TADJ	I/O	Center frequency setting pin for the internal circuit BPF3T
24	Vcc	—	+3V power supply
25	WBLADJ	I/O	Center frequency setting pin for the internal circuit BPF22
26	TE	O	Tracking error signal output to the CXD2662R
27	CSLED	—	External capacitor connection pin for the sled error signal LPF
28	SE	O	Sled error signal output to the CXD2662R
29	ADFM	O	FM signal output of ADIP
30	ADIN	I	ADIP signal comparator input ADFM is connected with AC coupling
31	ADAGC	—	External capacitor connection pin for AGC of ADIP
32	ADFG	O	ADIP duplex signal output to the CXD2662R
33	AUX	O	I3 signal/temperature signal output to the CXD2662R (Switching with a serial command)
34	FE	O	Focus error signal output to the CXD2662R
35	ABCD	O	Light amount signal output to the CXD2662R
36	BOTM	O	RF/ABCD bottom hold signal output to the CXD2662R
37	PEAK	O	RF/ABCD peak hold signal output to the CXD2662R
38	RF	O	RF equalizer output to the CXD2662R
39	RFAGC	—	External capacitor connection pin for the RF AGC circuit
40	AGCI	I	Input to the RF AGC circuit The RF amplifier output is input with AC coupling
41	COMPO	O	User comparator output (Not used)
42	COMPP	I	User comparator input (Fixed at “L”)
43	ADDC	I/O	External capacitor pin for cutting the low band of the ADIP amplifier
44	OPO	O	User operation amplifier output (Not used)
45	OPN	I	User operation amplifier inversion input (Fixed at “L”)
46	RFO	O	RF amplifier output
47	MORFI	I	Groove RF signal is input with AC coupling
48	MORFO	O	Groove RF signal output

- Abbreviation
APC: Auto Power Control
AGC: Auto Gain Control

• IC151 CXD2662R Digital Signal Processor, Digital Servo Signal Processor (BD BOARD)

Pin No.	Pin Name	I/O	Function
1	MNT0 (FOK)	O	FOK signal output to the system control (monitor output) “H” is output when focus is on
2	MNT1 (SHCK)	O	Track jump detection signal output to the system control (monitor output)
3	MNT2 (XBUSY)	O	Monitor 2 output to the system control (monitor output)
4	MNT3 (SLOC)	O	Monitor 3 output to the system control (monitor output)
5	SWDT	I	Writing data signal input from the system control
6	SCLK	I (S)	Serial clock signal input from the system control
7	XLAT	I (S)	Serial latch signal input from the system control
8	SRDT	O (3)	Reading data signal output to the system control
9	SENS	O (3)	Internal status (SENSE) output to the system control
10	XRST	I (S)	Reset signal input from the system control “L”: Reset
11	SQSY	O	Subcode Q sync (SCOR) output to the system control “L” is output every 13.3 msec. Almost all, “H” is output
12	DQSY	O	Digital In U-bit CD format or MD format subcode Q sync (SCOR) output to the system control
13	RECP	I	Laser power switching input from the system control “H”: Recording, “L”: Playback
14	XINT	O	Interrupt status output to the system control
15	TX	I	Recording data output enable input from the system control
16	OSCI	I	System clock input (512Fs=22.5792 MHz)
17	OSCO	O	System clock output (512Fs=22.5792 MHz) (Not used)
18	XTSL	I	System clock frequency setting “L”: 45.1584 MHz, “H”: 22.5792 MHz (Fixed at “H”)
19	DIN0	I	Digital audio input (Optical input)
20	DIN1	I	Digital audio input (Optical input)
21	DOUT	O	Digital audio output (Optical output)
22	DADTI	I	Serial data input
23	LRCKI	I	LR clock input “H” : Lch, “L” : R ch
24	XBCKI	I	Serial data clock input
25	ADDT	I	Data input from the A/D converter
26	DADT	O	Data output to the D/A converter
27	LRCK	O	LR clock output for the A/D and D/A converter (44.1 kHz)
28	XBCK	O	Bit clock output to the A/D and D/A converter (2.8224 MHz)
29	FS256	O	11.2896 MHz clock output (Not used)
30	DVDD	—	+3V power supply (Digital)
31 to 34	A03 to A00	O	DRAM address output
35	A10	O	DRAM address output (Not used)
36 to 40	A04 to A08	O	DRAM address output
41	A11	O	DRAM address output (Not used)
42	DVSS	—	Ground (Digital)
43	XOE	O	Output enable output for DRAM
44	XCAS	O	$\overline{\text{CAS}}$ signal output for DRAM
45	A09	O	Address output for DRAM
46	XRAS	O	$\overline{\text{RAS}}$ signal output for DRAM
47	XWE	O	Write enable signal output for DRAM
48	D1	I/O	Data input/output for DRAM
49	D0	I/O	
50, 51	D2, D3	I/O	

* I (S) stands for Schmidt input, I (A) for analog input, O (3) for 3-state output, and O (A) for analog output in the column I/O

Pin No.	Pin Name	I/O	Function
52	MVCI	I (S)	Clock input from an external VCO (Fixed at "L")
53	ASYO	O	Playback EFM duplex signal output
54	ASYI	I (A)	Playback EFM comparator slice level input
55	AVDD	—	+3V power supply (Analog)
56	BIAS	I (A)	Playback EFM comparator bias current input
57	RFI	I (A)	Playback EFM RF signal input
58	AVSS	—	Ground (Analog)
59	PCO	O (3)	Phase comparison output for the recording/playback EFM master PLL
60	FILI	I (A)	Filter input for the recording/playback EFM master PLL
61	FILO	O (A)	Filter output for the recording/playback EFM master PLL
62	CLTV	I (A)	Internal VCO control voltage input for the recording/playback EFM master PLL
63	PEAK	I (A)	Light amount signal peak hold input from the CXA2523AR
64	BOTM	I (A)	Light amount signal bottom hold input from the CXA2523AR
65	ABCD	I (A)	Light amount signal input from the CXA2523AR
66	FE	I (A)	Focus error signal input from the CXA2523AR
67	AUX1	I (A)	Auxiliary A/D input
68	VC	I (A)	Middle point voltage (+1.5V) input from the CXA2523AR
69	ADIO	O (A)	Monitor output of the A/D converter input signal (Not used)
70	AVDD	—	+3V power supply (Analog)
71	ADRT	I (A)	A/D converter operational range upper limit voltage input (Fixed at "H")
72	ADRB	I (A)	A/D converter operational range lower limit voltage input (Fixed at "L")
73	AVSS	—	Ground (Analog)
74	SE	I (A)	Sled error signal input from the CXA2523AR
75	TE	I (A)	Tracking error signal input from the CXA2523AR
76	DCHG	I (A)	Connected to +3V power supply
77	APC	I (A)	Error signal input for the laser digital APC (Fixed at "L")
78	ADFG	I (S)	ADIP duplex FM signal input from the CXA2523AR (22.05 ± 1 kHz)
79	FOCNT	O	Filter f ₀ control output to the CXA2523AR
80	XLRF	O	Control latch output to the CXA2523AR
81	CKRF	O	Control clock output to the CXA2523AR
82	DTRF	O	Control data output to the CXA2523AR
83	APCREF	O	Reference PWM output for the laser APC
84	TEST0	O	PWM output for the laser digital APC (Not used)
85	TRDR	O	Tracking servo drive PWM output (-)
86	TFDR	O	Tracking servo drive PWM output (+)
87	DVDD	—	+3V power supply (Digital)
88	FFDR	O	Focus servo drive PWM output (+)
89	FRDR	O	Focus servo drive PWM output (-)
90	FS4	O	176.4 kHz clock signal output (X'tal) (Not used)
91	SRDR	O	Sled servo drive PWM output (-)
92	SFDR	O	Sled servo drive PWM output (+)
93	SPRD	O	Spindle servo drive PWM output (-)
94	SPFD	O	Spindle servo drive PWM output (+)
95	FGIN	I (S)	Test input (Fixed at "L")
96 to 98	TEST1 to TEST3	I	
99	DVSS	—	Ground (Digital)
100	EFMO	O	EFM output when recording

- Abbreviation
EFM: Eight to Fourteen Modulation
PLL : Phase Locked Loop
VCO: Voltage Controlled Oscillator

• IC300 M30805SGP (MAIN BOARD)

Pin No.	Pin Name	I/O	Function
1	DATA(FL)	O	Serial data signal output to the display driver
2	CLK(FL)	O	Serial clock signal output to the display driver L: Active
3	A1-IN	I	Fixed at H (Pull-up)
4	SIRCS	I	Remote control input
5, 6	NC	—	Not used
7	LED	O	LCD back light ON/OFF signal output
8	MUTE	O	Mute signal output
9	A/D, D/A RESET	O	A/D, D/A (AK4524-TP) reset signal output
10	A/D, D/A LATCH	O	A/D, D/A (AK4524-TP) chip secect signal output
11	LD-LOW	O	Loading motor voltage control output L: High voltage H: Low voltage
12	LDIN	I	Loading motor control input H: IN
13	LDOUT	O	Loading motor control output H: OUT
14	MOD	O	Laser modulation switching signal output L: OFF H: ON
15	BYTE	I	Data bus changed input (Connected to ground)
16	CNVSS	—	Ground
17	XIN-T	I	Not used
18	XOUT-T	O	Not used
19	RESET	I	System rest input L : reset
20	XOUT	O	Main clock output (10MHz)
21	VSS	—	Ground
22	XIN	I	Main clock input (10MHz)
23	VCC	—	Power supply (+3.3V)
24	NMI	I	Fixed at H (Pull-up)
25	DQSY	I	Digital in sync input
26	PDOWN	I	Power down detection input L: Power down
27	SQSY	I	ADIP (MO) sync or subcode Q (PIT) sync input from CXD2662R (Playback system)
28	K.B-CLK	I	Fixed at H (Pull-up)
29	LDON	O	Laser ON/OFF control output H: Laser ON
30	LIMIT-IN	I	Detection input from the limit switch L: Sled limit-In H: Sled limit-Out
31	A1 OUT	O	Not used
32	XINIT	I	Interrupt status input from CXD2662R
33	BEEP	O	Not used
34	LRCK1	O	Not used
35	WR PWR	O	Write power ON/OFF output L: OFF H: ON
36	IIC CLK	O	IIC clock output
37	IIC DATA	I/O	IIC data input/output to the CONTROL-I
38	SWDT	O	Writing data signal output to the serial bus
39	VCC	—	Power supply (+3.3V)
40	SRDT	I	Reading data signal input from the serial bus
41	VSS	—	Ground
42	SCLK	O	Clock signal output to the serial bus
43	REC-SW	I	Detection signal input from the recording position detection switch L: REC
44	CLIP DATA	O	CLIP serial data output
45	CLIP DATA	I	CLIP serial data input
46	CLIP CLK	O	CLIP serial clock output (Not used)
47	DIG-RST	O	Digital rest signal output to the CXD2662R and motor driver L: Reset
48	SENS	I	Internal status (SENSE) input from the CXD2662R
49	PLAY-SW	I	Detection signal input from the playback position detection switch L: PLAY
50	XLATCH	O	Latch signal output to the serial bus
51	OUT-SW	I	Detection signal input from the loading out detection switch
52	RDY	I	Fixed at H (Pull-up)
53	ALE/RAS	O	Microprocessor mode output (Not used)
54	HOLD	I	Fixed at H (Pull-up)
55	HLDA/ALE	O	Microprocessor mode output (Not used)
56	XBUSY (MNT2)	I	In the state of executive command from the CXD2662R
57	VSS	—	Ground

Pin No.	Pin Name	I/O	Function
58	SHCK (MNT1)	I	Track jump signal input from the CXD2662R
59	VCC	—	Power supply (+3.3V)
60	EEP-WP	O	EEP-ROM write protect signal output L: write possibility
61	SDA	I/O	Data signal input/output pin with the EEPROM
62	BUSCLK	O	Not used
63	OE	O	Not used
64	CASH	O	Not used
65	WE R/W	O	Write signal output
66	SCL	O	Clock signal output to the EEPROM
67	REFLECT-SW	I	Disk reflection rate detection input from the reflect detection switch H: Disk with low reflection rate
68	PROTECT-SW	I	Recording-protection claw detection input from the protection detection switch H: Protect
69	CS0	O	Chip select signal output to the Flash ROM
70	CS1	O	Not used
71	CS2	O	Not used
72	A20	O	Address bus signal output to Flash ROM (Not used)
73	A19	O	Address bus signal output to Flash ROM
74	VCC	—	Power supply (+3.3V)
75	A18	O	Address bus signal output to Flash ROM
76	VSS	—	Ground
77 to 85	A17 to A9	O	Address bus signal output to Flash ROM
86 to 89	MODEL SEL-1-4	O	Not used
90	WP	O	Write protect signal to the Flash ROM
91	VCC	—	Power supply (+3.3V)
92	A8	O	Address bus signal output to Flash ROM
93	VSS	—	Ground
94 to 100	A7 to A1	O	Address bus signal output to Flash ROM
101	A0 LB	O	Not used
102 to 113	D15 to D4	I/O	Data bus signal input/output to the Flash ROM
114	KB.CLK-CTL	O	Not used
115	IIC BUSY	I	IIC busy signal input
116	KB DATA	I	fixed at H (Pull-up)
117	REC-VOL-B	O	Not used
118	REC-VOL-A	O	Not used
119 to 122	D3 to D0	I/O	Data bus signal input/output to the Flash ROM
123	JOG0	I	JOG encoder signal input
124	JOG1	I	JOG encoder signal input
125	LATCH (AD)	O	Not used
126	REC	O	Not used
127	L: DIN1/H: CLIP	O	Not used
128	CS (FL)	O	Chip select signal output to the display driver
129	POWER (IIC)	O	CONTROL-I power ON/OFF signal output
130	VSS	—	Ground
131	STB	O	Strobe signal output (Not used)
132	VCC	—	Power supply. (+3.3V)
133	IOP	I	Optical Pick-up IR power level detect signal input
134	A/D 6	I	Not used
135	A/D-5	I	Not used
136	TIMER/BEEP SW	I	Fixed at H (pull up)
137	KEY3	I	Fixed at H (pull up)
138	KEY2	I	Key input pin (A/D input)
139	KEY 1	I	Key input pin (A/D input)
140	AVSS	—	Ground (Analog)
141	KEY0	I	Key input pin (A/D input)
142	VREF	I	A/D reference voltage (Connect in sys 3.3V)
143	AVCC	—	BAK 3.3V
144	NC	I	Not used

SECTION 7 EXPLODED VIEWS

NOTE:

- -XX, -X mean standardized parts, so they may have some differences from the original one.
- Items marked "*" are not stocked since they are seldom required for routine service. Some delay should be anticipated when ordering these items.
- The mechanical parts with no reference number in the exploded views are not supplied.
- Hardware (# mark) list and accessories and packing materials are given in the last of this parts list.

- Abbreviation
CND : Canadian model
SP : Singapore model
MY : Malaysia model

The components identified by mark \triangle or dotted line with mark \triangle are critical for safety. Replace only with part number specified.

Les composants identifiés par une marque \triangle sont critiques pour la sécurité. Ne les remplacer que par une pièce portant le numéro spécifié.

7-1. CHASSIS SECTION

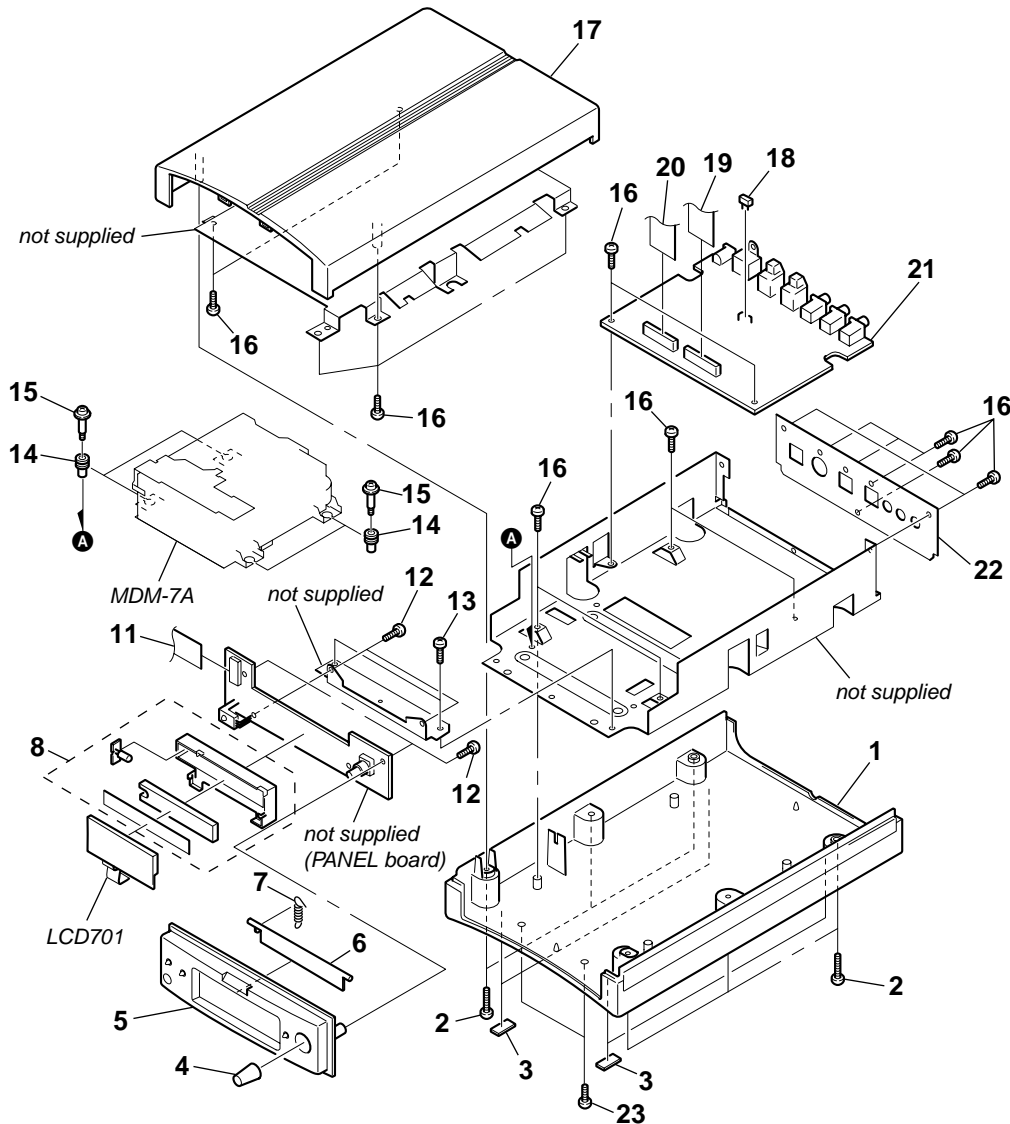

Ref. No.	Part No.	Description	Remarks	Ref. No.	Part No.	Description	Remarks
1	4-230-473-01	CASE(B)		16	7-685-646-79	SCREW +BVTP 3X8 TYPE2 N-S	
2	7-685-647-79	SCREW+BVTP 3X10 TYPE2 N-S		17	4-230-472-01	CASE(U)	
* 3	4-978-398-21	CUSHION		* 18	1-565-514-11	SOCKET, CONNECTOR 2P	
4	4-230-482-01	KNOB(AMS)		19	1-792-812-11	WIRE(FLAT TYPE) (27 CORE)	
5	X-4953-181-1	PANELASSY, FRONT		20	1-792-811-11	WIRE(FLAT TYPE) (23 CORE)	
6	4-230-848-71	LID (MD)		21	A-4725-377-A	MAINBOARD, COMPLETE (US)	
7	4-228-630-11	SPRING (LID), TENSION COIL		21	A-4725-378-A	MAINBOARD, COMPLETE (CND)	
8	1-804-189-11	LIGHT, LCD BACK		21	A-4725-379-A	MAINBOARD, COMPLETE (AEP)	
11	1-757-134-11	WIRE(FLAT TYPE) (13 CORE)		21	A-4725-380-A	MAINBOARD, COMPLETE (UK)	
12	4-951-620-01	SCREW (2.6X8), +BVTP		21	A-4725-381-A	MAINBOARD, COMPLETE (MY,SP)	
13	7-685-870-01	SCREW +BVTT 3X5 (S)		22	4-230-476-11	PANEL, BACK	
14	4-228-689-01	INSULATOR		23	7-682-248-04	SCREW (+K 3X8)	
15	4-228-643-21	SCREW (+BVTTWH M3), STEP		LCD701	1-804-188-11	LCD MODULE	

**7-2. MECHANISM SECTION-1
(MDM-7A)**

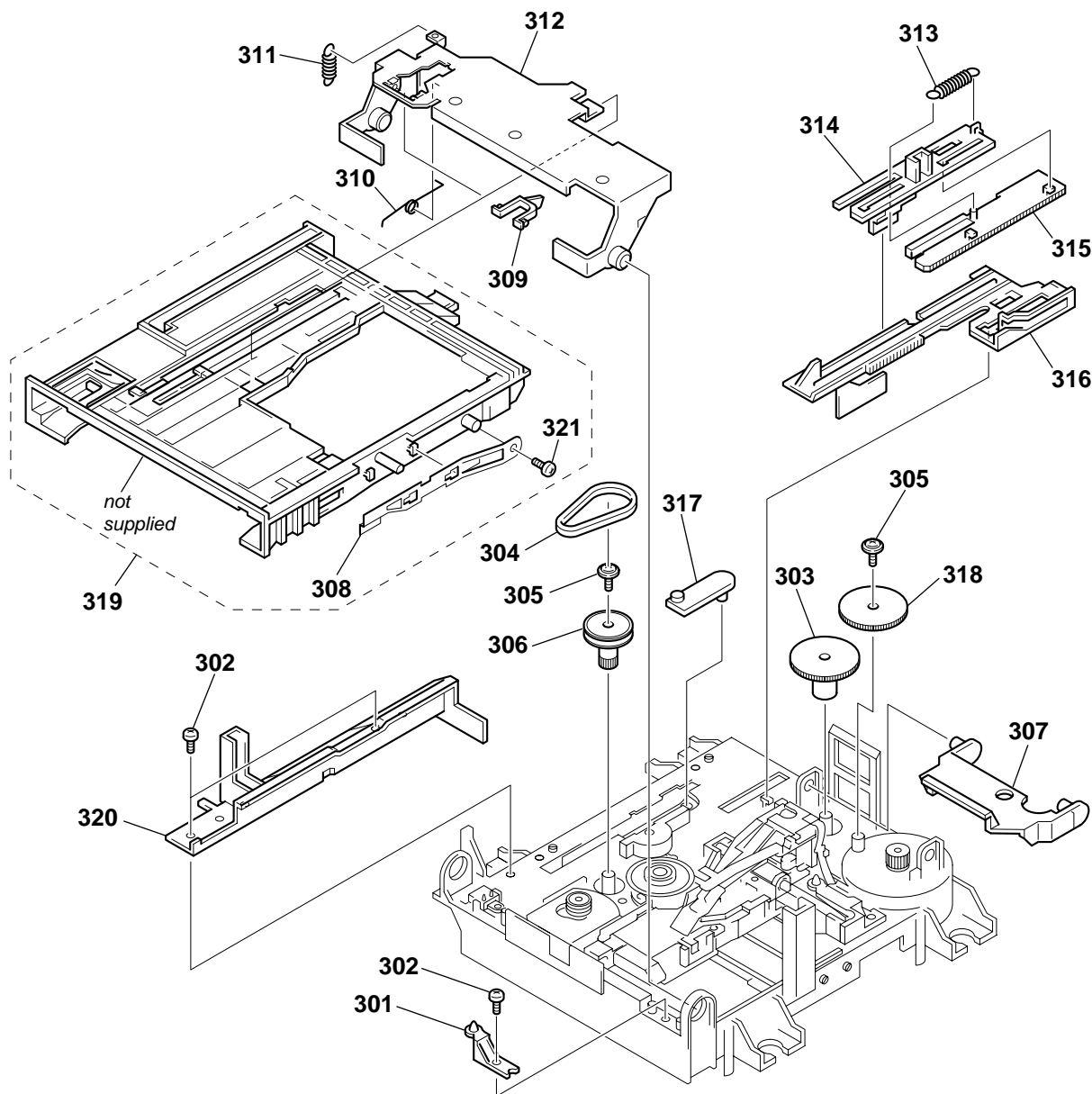

Ref. No.	Part No.	Description	Remarks	Ref. No.	Part No.	Description	Remarks
* 301	4-996-267-01	BASE (BU-D)		312	4-227-019-02	PLATE (HOLDER), RETAINER	
302	4-231-319-01	SCREW (2X6) CZN, +B (P) TRI		313	4-227-013-01	SPRING (EJ), TENSION	
303	4-227-007-01	GEAR (SB)		314	4-226-995-01	SLIDER (EJ)	
304	4-227-025-01	BELT (LOADING)		315	4-226-996-01	LIMITTER (EJ)	
305	3-372-761-01	SCREW (M1.7), TAPPING		316	4-226-997-04	SLIDER	
306	4-227-002-01	GEAR, PULLEY		317	4-226-998-01	LEVER (CHG)	
307	4-226-999-01	LEVER (HEAD)		318	4-227-006-01	GEAR (SA)	
308	X-4952-665-1	SPRING (SHT) ASSY, LEAF		319	A-4735-075-A	HOLDER ASSY	
309	4-228-923-01	LOCK (HOLDER)		320	4-226-994-01	GUIDE (L)	
310	4-229-533-02	SPRING (STOPPER), TORSION		321	7-685-850-04	SCREW +BVTT 2X3 (S)	
311	4-231-118-01	SPRING (HOLDER), TENSION					

**7-3. MECHANISM SECTION-2
(MDM-7A)**

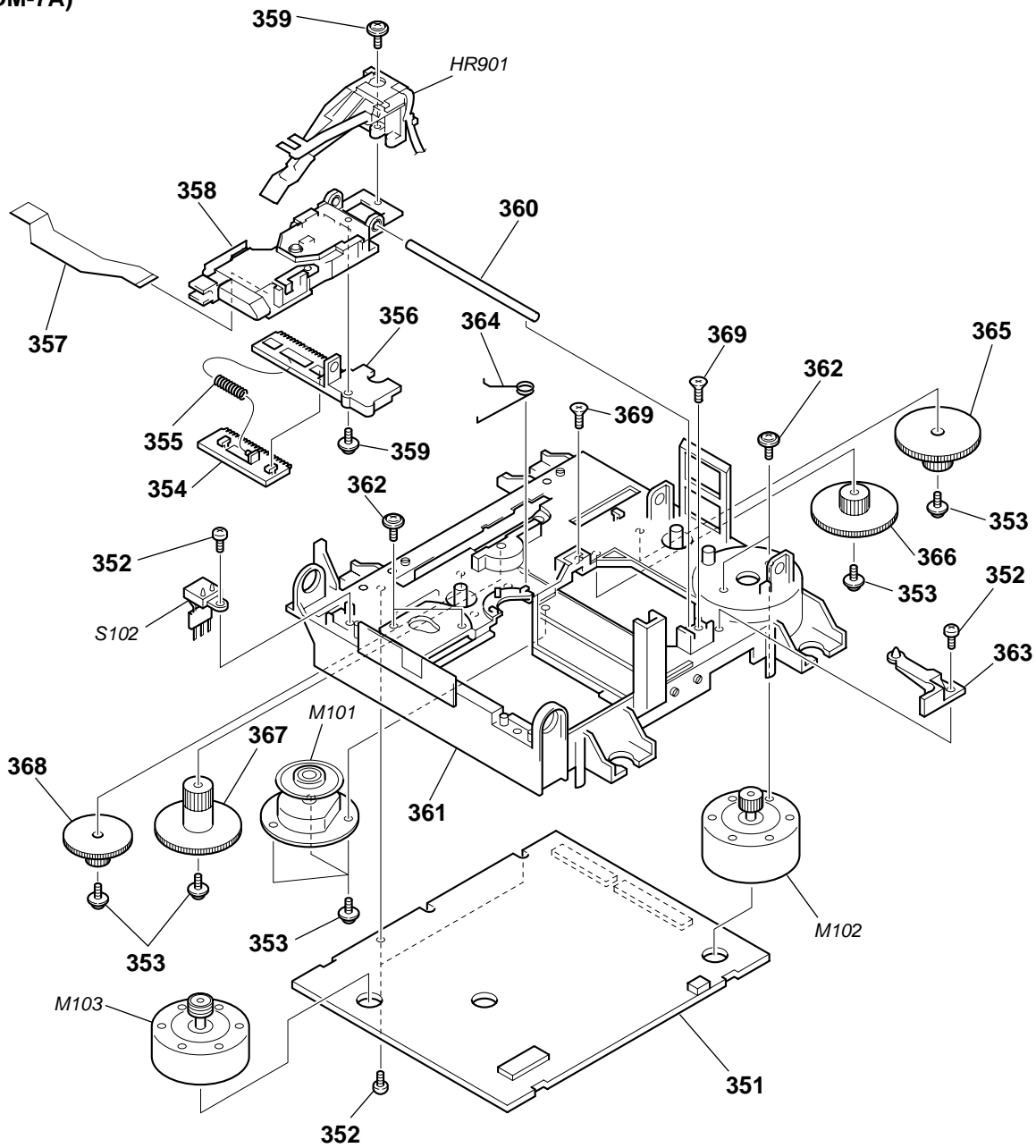

Ref. No.	Part No.	Description	Remarks	Ref. No.	Part No.	Description	Remarks
351	A-4725-054-A	BDBOARD, COMPLETE		363	4-226-990-01	BASE (BU-A)	
352	4-231-319-01	SCREW (2X6) CZN, +B (P) TRI		364	4-227-023-01	SPRING (SPINDLE), TORSION	
353	3-372-761-01	SCREW (M1.7), TAPPING		365	4-227-004-01	GEAR (LC)	
354	4-226-993-01	RACK		366	4-227-005-01	GEAR (LD)	
355	4-227-014-01	SPRING (RACK), COMPRESSION		367	4-227-009-01	GEAR (SD)	
356	4-226-992-01	BASE, SL		368	4-227-008-01	GEAR (SC)	
357	1-678-514-11	FLEXIBLE BOARD		369	7-685-204-19	SCREW +KTP 2X6 TYPE2 NON-SLIT	
△ 358	A-4672-541-A	OPTICAL PICK-UP KMS-260B/J1N		M101	A-4672-898-A	MOTOR ASSY, SPINDLE	
359	4-988-560-01	SCREW (+P 1.7X6)		M102	A-4672-900-A	MOTOR ASSY, SLED	
360	4-996-265-01	SHAFT, MAIN		M103	A-4672-975-A	MOTOR ASSY, LOADING	
361	4-226-989-01	CHASSIS		S102	1-771-957-11	SWITCH, PUSH (2 KEY) (REFLECT/PROTECT SW)	
362	4-211-036-01	SCREW (1.7X2.5), +PWH		HR901	1-500-670-12	HEAD, OVER LIGHT	

The components identified by mark \triangle or dotted line with mark \triangle are critical for safety. Replace only with part number specified.

Les composants identifiés par une marque \triangle sont critiques pour la sécurité. Ne les remplacer que par une pièce portant le numéro spécifié.

SECTION 8 ELECTRICAL PARTS LIST

BD

NOTE:

- Due to standardization, replacements in the parts list may be different from the parts specified in the diagrams or the components used on the set.
- -XX, -X mean standardized parts, so they may have some difference from the original one.
- Items marked "*" are not stocked since they are seldom required for routine service. Some delay should be anticipated when ordering these items.
- CAPACITORS:
uF: μ F
- RESISTORS
All resistors are in ohms.
METAL: metal-film resistor
METAL OXIDE: Metal Oxide-film resistor
F: nonflammable

- COILS
uH: μ H
- SEMICONDUCTORS
In each case, u: μ , for example:
uA...: μ A..., uPA..., μ PA...,
uPB..., μ PB..., uPC..., μ PC...,
uPD..., μ PD...
- Abbreviation
CND : Canadian model
SP : Singapore model
MY : Malaysia model

When indicating parts by reference number, please include the board name.

The components identified by mark Δ or dotted line with mark Δ are critical for safety. Replace only with part number specified.

Les composants identifiés par une marque Δ sont critiques pour la sécurité. Ne les remplacer que par une pièce portant le numéro spécifié.

Ref. No.	Part No.	Description	Remarks	Ref. No.	Part No.	Description	Remarks
	A-4725-054-A	BD BOARD, COMPLETE *****					
		< CAPACITOR >					
C101	1-135-259-11	TANTAL. CHIP 10uF	20% 6.3V	C158	1-162-927-11	CERAMIC CHIP 100PF	5% 50V
C102	1-135-259-11	TANTAL. CHIP 10uF	20% 6.3V	C159	1-162-927-11	CERAMIC CHIP 100PF	5% 50V
C103	1-162-970-11	CERAMIC CHIP 0.01uF	10% 25V	C160	1-162-927-11	CERAMIC CHIP 100PF	5% 50V
C104	1-164-227-11	CERAMIC CHIP 0.022uF	10% 25V	C161	1-162-970-11	CERAMIC CHIP 0.01uF	10% 25V
C105	1-115-416-11	CERAMIC CHIP 0.001uF	5% 25V	C162	1-162-970-11	CERAMIC CHIP 0.01uF	10% 25V
C106	1-162-970-11	CERAMIC CHIP 0.01uF	10% 25V	C163	1-125-891-11	CERAMIC CHIP 0.47uF	10% 10V
C107	1-162-970-11	CERAMIC CHIP 0.01uF	10% 25V	C164	1-162-927-11	CERAMIC CHIP 100PF	5% 50V
C108	1-162-969-11	CERAMIC CHIP 0.0068uF	10% 25V	C165	1-162-968-11	CERAMIC CHIP 0.0047uF	10% 50V
C109	1-164-677-11	CERAMIC CHIP 0.033uF	10% 16V	C166	1-125-891-11	CERAMIC CHIP 0.47uF	10% 10V
C110	1-163-038-11	CERAMIC CHIP 0.1uF	25V	C167	1-164-245-11	CERAMIC CHIP 0.015uF	10% 25V
C111	1-117-720-11	CERAMIC CHIP 4.7uF	10V	C169	1-164-156-11	CERAMIC CHIP 0.1uF	25V
C112	1-110-563-11	CERAMIC CHIP 0.068uF	10% 16V	C171	1-164-156-11	CERAMIC CHIP 0.1uF	25V
C113	1-162-968-11	CERAMIC CHIP 0.0047uF	10% 50V	C172	1-164-156-11	CERAMIC CHIP 0.1uF	25V
C114	1-125-837-91	CERAMIC CHIP 1uF	10% 6.3V	C180	1-117-370-11	CERAMIC CHIP 10uF	10V
C115	1-162-966-11	CERAMIC CHIP 0.0022uF	10% 50V	C181	1-126-206-11	ELECT CHIP 100uF	20% 6.3V
C116	1-164-227-11	CERAMIC CHIP 0.022uF	10% 25V	C182	1-163-038-11	CERAMIC CHIP 0.1uF	25V
C117	1-162-970-11	CERAMIC CHIP 0.01uF	10% 25V	C183	1-164-156-11	CERAMIC CHIP 0.1uF	25V
C118	1-165-176-11	CERAMIC CHIP 0.047uF	10% 16V	C184	1-117-970-11	ELECT CHIP 22uF	20% 10V
C119	1-165-176-11	CERAMIC CHIP 0.047uF	10% 16V	C185	1-131-872-91	CERAMIC CHIP 1000PF	10% 630V
C120	1-164-156-11	CERAMIC CHIP 0.1uF	25V	C191	1-126-206-11	ELECT CHIP 100uF	20% 6.3V
C121	1-164-156-11	CERAMIC CHIP 0.1uF	25V	C192	1-164-156-11	CERAMIC CHIP 0.1uF	25V
C125	1-117-720-11	CERAMIC CHIP 4.7uF	10V	C193	1-126-206-11	ELECT CHIP 100uF	20% 6.3V
C128	1-164-156-11	CERAMIC CHIP 0.1uF	25V	C194	1-164-156-11	CERAMIC CHIP 0.1uF	25V
C131	1-117-720-11	CERAMIC CHIP 4.7uF	10V	C195	1-164-156-11	CERAMIC CHIP 0.1uF	25V
C132	1-164-156-11	CERAMIC CHIP 0.1uF	25V	C196	1-164-156-11	CERAMIC CHIP 0.1uF	25V
C133	1-164-156-11	CERAMIC CHIP 0.1uF	25V	C1401	1-117-720-11	CERAMIC CHIP 4.7uF	10V
C141	1-126-206-11	ELECT CHIP 100uF	20% 6.3V			< CONNECTOR >	
C142	1-164-156-11	CERAMIC CHIP 0.1uF	25V	CN101	1-766-833-21	CONNECTOR, FFC/FPC (ZIF) 21P	
C143	1-164-156-11	CERAMIC CHIP 0.1uF	25V	CN102	1-784-835-21	CONNECTOR, FFC(LIF(NON-ZIF))27P	
C144	1-162-970-11	CERAMIC CHIP 0.01uF	10% 25V	CN103	1-784-834-21	CONNECTOR, FFC(LIF(NON-ZIF))23P	
C145	1-164-156-11	CERAMIC CHIP 0.1uF	25V	* CN104	1-580-055-21	PIN, CONNECTOR (SMD) 2P	
C146	1-117-720-11	CERAMIC CHIP 4.7uF	10V	CN105	1-784-859-21	CONNECTOR, FFC(LIF(NON-ZIF))7P	
C147	1-117-720-11	CERAMIC CHIP 4.7uF	10V			< DIODE >	
C151	1-117-370-11	CERAMIC CHIP 10uF	10V	D101	8-719-988-61	DIODE 1SS355TE-17	
C152	1-164-156-11	CERAMIC CHIP 0.1uF	25V	D181	8-719-080-81	DIODE DIODE FS1J6	
C153	1-164-156-11	CERAMIC CHIP 0.1uF	25V	D183	8-719-080-81	DIODE DIODE FS1J6	
C154	1-126-206-11	ELECT CHIP 100uF	20% 6.3V			< IC >	
C155	1-164-156-11	CERAMIC CHIP 0.1uF	25V	IC101	8-752-080-95	IC CXA2523AR	
C156	1-164-156-11	CERAMIC CHIP 0.1uF	25V	IC102	8-759-473-51	IC TLV2361CDBV	
C157	1-164-156-11	CERAMIC CHIP 0.1uF	25V	IC141	8-759-430-25	IC BH6511FS	
				IC151	8-752-404-64	IC IC CXD2662R	
				IC153	8-759-671-27	IC IC MSM51V4400E-70TS-K	

Ref. No.	Part No.	Description	Remarks	Ref. No.	Part No.	Description	Remarks
IC171	8-759-096-87	IC TC7WU04FU(TE12R)		R111	1-216-833-11	METAL CHIP 10K 5%	1/16W
IC181	8-759-481-17	IC MC74ACT08DTR2		R112	1-216-829-11	METAL CHIP 4.7K 5%	1/16W
IC190	8-759-460-72	IC BA033FP-E2		R113	1-216-833-11	METAL CHIP 10K 5%	1/16W
IC195	8-759-640-41	IC IC BR24C08F-E2		R114	1-216-827-11	METAL CHIP 3.3K 5%	1/16W
		< JUMPER RESISTOR >		R115	1-216-833-11	METAL CHIP 10K 5%	1/16W
JW201	1-216-295-11	SHORT 0		R116	1-216-839-11	METAL CHIP 33K 5%	1/16W
JW202	1-216-295-11	SHORT 0		R117	1-216-837-11	METAL CHIP 22K 5%	1/16W
JW203	1-216-295-11	SHORT 0		R118	1-218-855-11	METAL CHIP 2.2K 0.5%	1/16W
JW903	1-216-295-11	SHORT 0		R119	1-218-863-11	METAL CHIP 4.7K 0.5%	1/16W
JW904	1-216-295-11	SHORT 0		R120	1-218-889-11	METAL CHIP 56K 0.5%	1/16W
		< COIL >		R121	1-218-863-11	METAL CHIP 4.7K 0.5%	1/16W
L101	1-500-245-11	INDUCTOR 0uH		R122	1-218-855-11	METAL CHIP 2.2K 0.5%	1/16W
L102	1-500-245-11	INDUCTOR 0uH		R123	1-216-819-11	METAL CHIP 680 5%	1/16W
L103	1-500-245-11	INDUCTOR 0uH		R124	1-216-809-11	METAL CHIP 100 5%	1/16W
L105	1-414-235-22	INDUCTOR 0uH		R125	1-216-815-11	METAL CHIP 330 5%	1/16W
L106	1-500-245-11	INDUCTOR 0uH		R126	1-216-819-11	METAL CHIP 680 5%	1/16W
L121	1-500-245-11	INDUCTOR 0uH		R127	1-216-845-11	METAL CHIP 100K 5%	1/16W
L122	1-500-245-11	INDUCTOR 0uH		R128	1-219-724-11	METAL CHIP 1 1%	1/4W
L131	1-500-245-11	INDUCTOR 0uH		R129	1-216-298-00	METAL CHIP 2.2 5%	1/10W
L141	1-412-029-11	INDUCTOR CHIP 10uH		R130	1-216-829-11	METAL CHIP 4.7K 5%	1/16W
L142	1-412-032-11	INDUCTOR CHIP 100uH		R131	1-216-833-11	METAL CHIP 10K 5%	1/16W
L143	1-412-029-11	INDUCTOR CHIP 10uH		R132	1-216-841-11	METAL CHIP 47K 5%	1/16W
L144	1-412-032-11	INDUCTOR CHIP 100uH		R133	1-216-821-11	METAL CHIP 1K 5%	1/16W
L145	1-412-032-11	INDUCTOR CHIP 100uH		R134	1-216-821-11	METAL CHIP 1K 5%	1/16W
L146	1-469-855-21	FERRITE 0uH		R135	1-216-821-11	METAL CHIP 1K 5%	1/16W
L147	1-469-855-21	FERRITE 0uH		R136	1-216-295-11	SHORT 0	
L161	1-500-245-11	INDUCTOR 0uH		R138	1-216-833-11	METAL CHIP 10K 5%	1/16W
L171	1-500-245-11	INDUCTOR 0uH		R150	1-216-833-11	METAL CHIP 10K 5%	1/16W
L180	1-469-855-21	FERRITE 0uH		R151	1-216-833-11	METAL CHIP 10K 5%	1/16W
L181	1-469-855-21	FERRITE 0uH		R154	1-216-833-11	METAL CHIP 10K 5%	1/16W
L182	1-500-245-11	INDUCTOR 0uH		R155	1-216-864-11	METAL CHIP 0 5%	1/16W
L183	1-216-296-91	SHORT 0		R156	1-216-864-11	METAL CHIP 0 5%	1/16W
L184	1-216-296-91	SHORT 0		R157	1-216-809-11	METAL CHIP 100 5%	1/16W
		< TRANSISTOR >		R158	1-216-809-11	METAL CHIP 100 5%	1/16W
Q101	8-729-403-35	TRANSISTOR UN5113		R159	1-216-833-11	METAL CHIP 10K 5%	1/16W
Q121	8-729-403-35	TRANSISTOR UN5113		R160	1-216-833-11	METAL CHIP 10K 5%	1/16W
Q122	8-729-101-07	TRANSISTOR 2SB798-DL		R161	1-216-833-11	METAL CHIP 10K 5%	1/16W
Q131	8-729-026-53	TRANSISTOR 2SA1576A-T106-QR		R163	1-216-809-11	METAL CHIP 100 5%	1/16W
Q132	8-729-903-10	TRANSISTOR FMW1		R164	1-216-809-11	METAL CHIP 100 5%	1/16W
Q133	8-729-402-93	TRANSISTOR UN5214-TX		R165	1-216-809-11	METAL CHIP 100 5%	1/16W
Q134	8-729-402-93	TRANSISTOR UN5214-TX		R167	1-216-833-11	METAL CHIP 10K 5%	1/16W
Q181	8-729-018-75	TRANSISTOR 2SJ278MY		R168	1-216-845-11	METAL CHIP 100K 5%	1/16W
Q182	8-729-017-65	TRANSISTOR 2SK1764KY		R169	1-216-855-11	METAL CHIP 680K 5%	1/16W
		< RESISTOR >		R170	1-216-827-11	METAL CHIP 3.3K 5%	1/16W
R101	1-216-829-11	METAL CHIP 4.7K 5%	1/16W	R171	1-216-821-11	METAL CHIP 1K 5%	1/16W
R102	1-216-853-11	METAL CHIP 470K 5%	1/16W	R173	1-216-821-11	METAL CHIP 1K 5%	1/16W
R103	1-216-863-11	RES-CHIP 3.3M 5%	1/16W	R174	1-216-811-11	METAL CHIP 150 5%	1/16W
R104	1-216-853-11	METAL CHIP 470K 5%	1/16W	R175	1-216-857-11	METAL CHIP 1M 5%	1/16W
R105	1-216-825-11	METAL CHIP 2.2K 5%	1/16W	R176	1-216-809-11	METAL CHIP 100 5%	1/16W
R106	1-216-825-11	METAL CHIP 2.2K 5%	1/16W	R179	1-216-295-11	SHORT 0	
R107	1-216-825-11	METAL CHIP 2.2K 5%	1/16W	R181	1-216-841-11	METAL CHIP 47K 5%	1/16W
R108	1-216-833-11	METAL CHIP 10K 5%	1/16W	R182	1-216-841-11	METAL CHIP 47K 5%	1/16W
R109	1-216-845-11	METAL CHIP 100K 5%	1/16W	R183	1-216-841-11	METAL CHIP 47K 5%	1/16W
R110	1-216-845-11	METAL CHIP 100K 5%	1/16W	R184	1-220-942-11	METAL CHIP 3.3 1%	1/4W
				R185	1-220-942-11	METAL CHIP 3.3 1%	1/4W
				R195	1-216-833-11	METAL CHIP 10K 5%	1/16W
				R196	1-216-833-11	METAL CHIP 10K 5%	1/16W
				R197	1-216-833-11	METAL CHIP 10K 5%	1/16W
				R218	1-216-864-11	METAL CHIP 0 5%	1/16W

Ref. No.	Part No.	Description	Remarks	Ref. No.	Part No.	Description	Remarks
		< SWITCH >		C319	1-164-156-11	CERAMIC CHIP 0.1uF	25V
S101	1-762-596-21	SWITCH, PUSH (1 KEY) (LIMIT IN SW)		C320	1-164-156-11	CERAMIC CHIP 0.1uF	25V
S103	1-771-956-21	SWITCH, PUSH (1 KEY) (OUT SW)		C321	1-801-862-11	VARISTOR, CHIP 1050PF	7.5V
S104	1-771-955-21	SWITCH, PUSH (1 KEY) (PLAY SW)		C401	1-164-156-11	CERAMIC CHIP 0.1uF	25V
S105	1-771-955-21	SWITCH, PUSH (1 KEY) (REC SW)		C402	1-164-156-11	CERAMIC CHIP 0.1uF	25V
*****				C404	1-164-156-11	CERAMIC CHIP 0.1uF	25V
A-4725-377-A	MAIN BOARD, COMPLETE (US)			C406	1-164-156-11	CERAMIC CHIP 0.1uF	25V
	*****			C407	1-128-547-11	ELECT 6800uF	20% 16V
A-4725-378-A	MAIN BOARD, COMPLETE (CND)			C408	1-164-156-11	CERAMIC CHIP 0.1uF	25V
	*****			C409	1-164-156-11	CERAMIC CHIP 0.1uF	25V
A-4725-379-A	MAIN BOARD, COMPLETE (AEP)			C410	1-119-879-11	ELECT 15uF	16V
	*****			C412	1-119-765-11	ELECT 47uF	20% 6.3V
A-4725-380-A	MAIN BOARD, COMPLETE (UK)			C413	1-126-926-11	ELECT 1000uF	20% 10V
	*****			C414	1-164-156-11	CERAMIC CHIP 0.1uF	25V
A-4725-381-A	MAIN BOARD, COMPLETE (MY,SP)			C415	1-164-156-11	CERAMIC CHIP 0.1uF	25V
	*****			C416	1-126-934-11	ELECT 220uF	20% 10V
		< CAPACITOR >		C420	1-165-112-11	CERAMIC CHIP 0.33uF	16V
C100	1-115-156-11	CERAMIC CHIP 1uF	10V	C421	1-164-156-11	CERAMIC CHIP 0.1uF	25V
C101	1-115-156-11	CERAMIC CHIP 1uF	10V	C430	1-126-926-11	ELECT 1000uF	20% 10V
C151	1-164-230-11	CERAMIC CHIP 220PF 5%	50V	C431	1-164-156-11	CERAMIC CHIP 0.1uF	25V
C152	1-128-551-11	ELECT 22uF 20%	25V	C432	1-164-156-11	CERAMIC CHIP 0.1uF	25V
C153	1-128-551-11	ELECT 22uF 20%	25V	C441	1-164-156-11	CERAMIC CHIP 0.1uF	25V
C161	1-164-230-11	CERAMIC CHIP 220PF 5%	50V	C450	1-126-934-11	ELECT 220uF	20% 10V
C165	1-162-927-11	CERAMIC CHIP 100PF 5%	50V	C451	1-164-156-11	CERAMIC CHIP 0.1uF	25V
C166	1-162-927-11	CERAMIC CHIP 100PF 5%	50V	C452	1-164-156-11	CERAMIC CHIP 0.1uF	25V
C176	1-128-551-11	ELECT 22uF 20%	25V	C453	1-164-156-11	CERAMIC CHIP 0.1uF	25V
C177	1-164-230-11	CERAMIC CHIP 220PF 5%	50V	C454	1-164-156-11	CERAMIC CHIP 0.1uF	25V
C180	1-126-960-11	ELECT 1uF 20%	50V	C456	1-126-934-11	ELECT 220uF	20% 10V
C181	1-126-934-11	ELECT 220uF 20%	10V	C457	1-126-934-11	ELECT 220uF	20% 10V
C182	1-164-230-11	CERAMIC CHIP 220PF 5%	50V	C458	1-126-934-11	ELECT 220uF	20% 10V
C251	1-164-230-11	CERAMIC CHIP 220PF 5%	50V	C459	1-115-156-11	CERAMIC CHIP 1uF	10V
C252	1-128-551-11	ELECT 22uF 20%	25V	C460	1-104-664-11	ELECT 47uF	20% 10V
C253	1-128-551-11	ELECT 22uF 20%	25V	C461	1-164-156-11	CERAMIC CHIP 0.1uF	25V
C261	1-164-230-11	CERAMIC CHIP 220PF 5%	50V	C462	1-164-156-11	CERAMIC CHIP 0.1uF	25V
C265	1-162-927-11	CERAMIC CHIP 100PF 5%	50V	C500	1-126-934-11	ELECT 220uF	20% 10V
C266	1-162-927-11	CERAMIC CHIP 100PF 5%	50V	C501	1-164-156-11	CERAMIC CHIP 0.1uF	25V
C276	1-128-551-11	ELECT 22uF 20%	25V	C502	1-162-966-11	CERAMIC CHIP 0.0022uF	10% 50V
C277	1-164-230-11	CERAMIC CHIP 220PF 5%	50V	C503	1-162-966-11	CERAMIC CHIP 0.0022uF	10% 50V
C280	1-126-960-11	ELECT 1uF 20%	50V	C504	1-104-665-11	ELECT 100uF	20% 10V
C281	1-126-934-11	ELECT 220uF 20%	10V	C505	1-164-156-11	CERAMIC CHIP 0.1uF	25V
C282	1-164-230-11	CERAMIC CHIP 220PF 5%	50V	C506	1-164-156-11	CERAMIC CHIP 0.1uF	25V
C301	1-126-791-11	ELECT 10uF 20%	16V	C507	1-164-156-11	CERAMIC CHIP 0.1uF	25V
C302	1-164-156-11	CERAMIC CHIP 0.1uF	25V	C515	1-162-927-11	CERAMIC CHIP 100PF	5% 50V
C304	1-162-927-11	CERAMIC CHIP 100PF 5%	50V	C516	1-162-927-11	CERAMIC CHIP 100PF	5% 50V
C306	1-164-230-11	CERAMIC CHIP 220PF 5%	50V	C517	1-162-927-11	CERAMIC CHIP 100PF	5% 50V
C307	1-164-230-11	CERAMIC CHIP 220PF 5%	50V	C519	1-162-964-11	CERAMIC CHIP 0.001uF	10% 50V
C308	1-162-964-11	CERAMIC CHIP 0.001uF 10%	50V	C520	1-126-934-11	ELECT 220uF	20% 10V
C309	1-164-156-11	CERAMIC CHIP 0.1uF	25V	C522	1-164-156-11	CERAMIC CHIP 0.1uF	25V
C311	1-162-964-11	CERAMIC CHIP 0.001uF 10%	50V	C523	1-104-665-11	ELECT 100uF	20% 10V
C312	1-162-964-11	CERAMIC CHIP 0.001uF 10%	50V	C524	1-164-156-11	CERAMIC CHIP 0.1uF	25V
C313	1-162-964-11	CERAMIC CHIP 0.001uF 10%	50V	C540	1-216-864-11	METAL CHIP 0	5% 1/16W
C314	1-162-964-11	CERAMIC CHIP 0.001uF 10%	50V	C550	1-104-665-11	ELECT 100uF	20% 10V
C315	1-162-964-11	CERAMIC CHIP 0.001uF 10%	50V	C551	1-164-156-11	CERAMIC CHIP 0.1uF	25V
C316	1-164-156-11	CERAMIC CHIP 0.1uF	25V	C552	1-162-910-11	CERAMIC CHIP 5PF	0.25PF 50V
C317	1-164-156-11	CERAMIC CHIP 0.1uF	25V	C553	1-162-917-11	CERAMIC CHIP 15PF	5% 50V
C318	1-164-156-11	CERAMIC CHIP 0.1uF	25V	C554	1-216-813-11	METAL CHIP 220	5% 1/16W
				C555	1-164-156-11	CERAMIC CHIP 0.1uF	25V
				C556	1-162-964-11	CERAMIC CHIP 0.001uF	10% 50V
				C601	1-164-156-11	CERAMIC CHIP 0.1uF	25V

MAIN

Ref. No.	Part No.	Description	Remarks	Ref. No.	Part No.	Description	Remarks	
C611	1-164-156-11	CERAMIC CHIP	0.1uF	25V		< COIL >		
C613	1-162-970-11	CERAMIC CHIP	0.01uF	10%	25V			
C661	1-164-156-11	CERAMIC CHIP	0.1uF	25V	L151	1-216-864-11	METAL CHIP 0 5% 1/16W	
C662	1-104-665-11	ELECT	100uF	20%	10V	L178	1-414-760-21	FERRITE 0uH
C800	1-164-156-11	CERAMIC CHIP	0.1uF	25V	L180	1-414-760-21	FERRITE 0uH	
C804	1-164-156-11	CERAMIC CHIP	0.1uF	25V	L251	1-216-864-11	METAL CHIP 0 5% 1/16W	
C814	1-164-156-11	CERAMIC CHIP	0.1uF	25V	L278	1-414-760-21	FERRITE 0uH	
C851	1-216-864-11	METAL CHIP	0	5%	1/16W	L280	1-414-760-21	FERRITE 0uH
C852	1-216-864-11	METAL CHIP	0	5%	1/16W	L400	1-424-674-11	INDUCTOR 22uH
C853	1-216-864-11	METAL CHIP	0	5%	1/16W	L501	1-414-760-21	FERRITE 0uH
C854	1-216-864-11	METAL CHIP	0	5%	1/16W	L502	1-414-760-21	FERRITE 0uH
C856	1-164-156-11	CERAMIC CHIP	0.1uF	25V	L503	1-414-760-21	FERRITE 0uH	
		< CONNECTOR >						
CN100	1-573-798-11	JACK, MINIATURE (DIA. 3.5) (ANALOG IN)				L504	1-216-864-11	METAL CHIP 0 5% 1/16W
CN101	1-784-384-11	CONNECTOR, FFC/FPC 27P				L550	1-414-760-21	FERRITE 0uH
CN102	1-793-991-11	CONNECTOR, FFC/FPC 23P				L551	1-164-156-11	CERAMIC CHIP 0.1uF 25V
CN103	1-784-373-21	CONNECTOR, FFC/FPC 14P				L552	1-414-760-21	FERRITE 0uH
CN200	1-573-798-11	JACK, MINIATURE (DIA. 3.5) (ANALOG OUT (VARIABLE))				L553	1-412-979-21	INDUCTOR 1uH
* CN420	1-565-513-11	PIN, CONNECTOR 2P				L611	1-216-864-11	METAL CHIP 0 5% 1/16W
		< DIODE >				L661	1-216-864-11	METAL CHIP 0 5% 1/16W
D155	8-719-988-61	DIODE 1SS355TE-17				L801	1-216-864-11	METAL CHIP 0 5% 1/16W
D156	8-719-988-61	DIODE 1SS355TE-17						< TRANSISTOR >
D255	8-719-988-61	DIODE 1SS355TE-17				Q100	8-729-015-74	TRANSISTOR UN5111
D256	8-719-988-61	DIODE 1SS355TE-17				Q170	8-729-046-97	TRANSISTOR 2SD1938(F)-T(TX).SO
D301	8-719-941-09	DIODE DAP202U				Q270	8-729-046-97	TRANSISTOR 2SD1938(F)-T(TX).SO
D400	8-719-313-73	DIODE SFPB-52				Q400	8-729-036-99	TRANSISTOR HAT1020R-EL
D402	8-719-313-73	DIODE SFPB-52				Q440	8-729-015-76	TRANSISTOR UN5211
D421	8-719-988-61	DIODE 1SS355TE-17				Q450	8-729-194-57	TRANSISTOR 2SC945-P
D422	8-719-074-34	DIODE RB495D-T146				Q451	8-729-015-76	TRANSISTOR UN5211
		< GROUND TERMINAL >						< RESISTOR >
EP550	1-537-771-21	TERMINAL BOARD, GROUND				R151	1-216-839-11	METAL CHIP 33K 5% 1/16W
		< IC >				R152	1-216-835-11	METAL CHIP 15K 5% 1/16W
IC300	8-759-698-95	IC M30805SGP				R153	1-216-849-11	METAL CHIP 220K 5% 1/16W
IC301	8-759-827-38	IC MT28F800B3WG-10T-PC3				R155	1-216-805-11	METAL CHIP 47 5% 1/16W
IC400	8-759-485-63	IC MAX1626ESA-TE2				R161	1-216-833-11	METAL CHIP 10K 5% 1/16W
IC401	8-759-712-90	IC XC61FN3012MR				R162	1-216-833-11	METAL CHIP 10K 5% 1/16W
IC402	8-759-460-72	IC BA033FP-E2				R163	1-216-833-11	METAL CHIP 10K 5% 1/16W
IC420	8-759-565-74	IC M62016FP-E1				R164	1-216-833-11	METAL CHIP 10K 5% 1/16W
IC440	8-759-481-19	IC LB1830M-S-TE-L				R165	1-218-716-11	METAL CHIP 10K 0.5% 1/16W
IC450	8-759-450-47	IC BA05T				R166	1-218-716-11	METAL CHIP 10K 0.5% 1/16W
IC451	8-759-712-91	IC XC6351A120MR				R170	1-216-833-11	METAL CHIP 10K 5% 1/16W
IC500	8-759-579-68	IC AK4524				R176	1-216-819-11	METAL CHIP 680 5% 1/16W
IC501	8-759-358-47	IC NJM2115V(Te2)				R177	1-216-845-11	METAL CHIP 100K 5% 1/16W
IC502	8-759-358-47	IC NJM2115V(Te2)				R178	1-216-815-11	METAL CHIP 330 5% 1/16W
IC503	8-759-713-72	IC BH3541F-E2				R180	1-216-789-11	METAL CHIP 2.2 5% 1/16W
IC550	8-759-591-61	IC TC7WHU04FU				R181	1-216-821-11	METAL CHIP 1K 5% 1/16W
IC600	8-759-096-87	IC TC7WU04FU(Te12R)				R251	1-216-839-11	METAL CHIP 33K 5% 1/16W
IC611	8-749-012-70	IC GP1F38R (DIGITAL OPTICAL IN)				R252	1-216-835-11	METAL CHIP 15K 5% 1/16W
IC661	8-749-012-69	IC GP1F38T (DIGITAL OPTICAL OUT)				R253	1-216-849-11	METAL CHIP 220K 5% 1/16W
IC800	8-759-549-80	IC P82B715TD.118				R255	1-216-805-11	METAL CHIP 47 5% 1/16W
		< JACK >				R261	1-216-833-11	METAL CHIP 10K 5% 1/16W
J180	1-507-678-51	JACK (PHONES)				R262	1-216-833-11	METAL CHIP 10K 5% 1/16W
J400	1-691-452-11	JACK,DC(POLARITY UNIFIET TYPE) (DC IN 9V)				R263	1-216-833-11	METAL CHIP 10K 5% 1/16W
J800	1-580-394-11	CONNECTOR, DIN 6P (PC LINK)				R264	1-216-833-11	METAL CHIP 10K 5% 1/16W
						R265	1-218-716-11	METAL CHIP 10K 0.5% 1/16W
						R266	1-218-716-11	METAL CHIP 10K 0.5% 1/16W
						R270	1-216-833-11	METAL CHIP 10K 5% 1/16W
						R276	1-216-819-11	METAL CHIP 680 5% 1/16W
						R277	1-216-845-11	METAL CHIP 100K 5% 1/16W
						R278	1-216-815-11	METAL CHIP 330 5% 1/16W

Ref. No.	Part No.	Description	Quantity	Tolerance	Remarks	Ref. No.	Part No.	Description	Quantity	Tolerance	Remarks
R280	1-216-789-11	METAL CHIP	2.2	5%	1/16W	R601	1-216-841-11	METAL CHIP	47K	5%	1/16W
R281	1-216-821-11	METAL CHIP	1K	5%	1/16W	R800	1-216-864-11	METAL CHIP	0	5%	1/16W
R301	1-216-864-11	METAL CHIP	0	5%	1/16W	R801	1-216-864-11	METAL CHIP	0	5%	1/16W
R302	1-216-864-11	METAL CHIP	0	5%	1/16W	R803	1-216-829-11	METAL CHIP	4.7K	5%	1/16W
R303	1-216-864-11	METAL CHIP	0	5%	1/16W	R804	1-216-821-11	METAL CHIP	1K	5%	1/16W
R304	1-216-864-11	METAL CHIP	0	5%	1/16W	R805	1-216-829-11	METAL CHIP	4.7K	5%	1/16W
R305	1-216-864-11	METAL CHIP	0	5%	1/16W	R806	1-216-833-11	METAL CHIP	10K	5%	1/16W
R306	1-216-864-11	METAL CHIP	0	5%	1/16W	R807	1-216-839-11	METAL CHIP	33K	5%	1/16W
R307	1-216-833-11	METAL CHIP	10K	5%	1/16W	R808	1-216-833-11	METAL CHIP	10K	5%	1/16W
R308	1-216-833-11	METAL CHIP	10K	5%	1/16W	R809	1-216-864-11	METAL CHIP	0	5%	1/16W
R309	1-216-833-11	METAL CHIP	10K	5%	1/16W	R810	1-216-864-11	METAL CHIP	0	5%	1/16W
R310	1-216-833-11	METAL CHIP	10K	5%	1/16W	< COMPOSITION CIRCUIT BLOCK >					
R311	1-216-833-11	METAL CHIP	10K	5%	1/16W	RB301	1-236-908-11	NETWORK RESISTOR (CHIP)	10K		
R312	1-216-833-11	METAL CHIP	10K	5%	1/16W	RB302	1-236-908-11	NETWORK RESISTOR (CHIP)	10K		
R313	1-216-833-11	METAL CHIP	10K	5%	1/16W	RB303	1-236-908-11	NETWORK RESISTOR (CHIP)	10K		
R314	1-216-833-11	METAL CHIP	10K	5%	1/16W	RB304	1-236-908-11	NETWORK RESISTOR (CHIP)	10K		
R315	1-216-833-11	METAL CHIP	10K	5%	1/16W	< TRANSFORMER >					
R316	1-216-833-11	METAL CHIP	10K	5%	1/16W	T400	1-411-312-11	FILTER, COMMON MODE			
R317	1-216-833-11	METAL CHIP	10K	5%	1/16W	< THERMISTOR(POSITIVE) >					
R318	1-216-833-11	METAL CHIP	10K	5%	1/16W	THP400	1-771-075-21	THERMISTOR, POSITIVE			
R319	1-216-833-11	METAL CHIP	10K	5%	1/16W	< VIBRATOR >					
R320	1-216-833-11	METAL CHIP	10K	5%	1/16W	X301	1-795-004-21	VIBRATOR, CERAMIC (10MHz)			
R321	1-216-833-11	METAL CHIP	10K	5%	1/16W	X550	1-781-998-11	VIBRATOR, CRYSTAL (45.1584MHz)			
R322	1-216-833-11	METAL CHIP	10K	5%	1/16W	*****					
R323	1-216-833-11	METAL CHIP	10K	5%	1/16W	PANEL BOARD					
R324	1-216-833-11	METAL CHIP	10K	5%	1/16W	*****					
R325	1-216-833-11	METAL CHIP	10K	5%	1/16W	< CAPACITOR >					
R326	1-216-845-11	METAL CHIP	100K	5%	1/16W	C701	1-126-206-11	ELECT CHIP	100uF	20%	6.3V
R327	1-216-845-11	METAL CHIP	100K	5%	1/16W	C740	1-162-964-11	CERAMIC CHIP	0.001uF	10%	50V
R329	1-216-833-11	METAL CHIP	10K	5%	1/16W	C741	1-162-964-11	CERAMIC CHIP	0.001uF	10%	50V
R330	1-216-833-11	METAL CHIP	10K	5%	1/16W	C748	1-164-156-11	CERAMIC CHIP	0.1uF		25V
R331	1-216-837-11	METAL CHIP	22K	5%	1/16W	C750	1-164-156-11	CERAMIC CHIP	0.1uF		25V
R332	1-216-864-11	METAL CHIP	0	5%	1/16W	C751	1-164-156-11	CERAMIC CHIP	0.1uF		25V
R334	1-216-864-11	METAL CHIP	0	5%	1/16W	C752	1-164-156-11	CERAMIC CHIP	0.1uF		25V
R401	1-240-037-91	METAL	0.05	1%	1/4W	C753	1-164-156-11	CERAMIC CHIP	0.1uF		25V
R403	1-218-708-11	METAL CHIP	4.7K	0.5%	1/16W	C754	1-164-156-11	CERAMIC CHIP	0.1uF		25V
R404	1-218-716-11	METAL CHIP	10K	0.5%	1/16W	C755	1-115-156-11	CERAMIC CHIP	1uF		10V
R421	1-216-813-11	METAL CHIP	220	5%	1/16W	C756	1-115-156-11	CERAMIC CHIP	1uF		10V
R430	1-216-815-11	METAL CHIP	330	5%	1/16W	C760	1-164-156-11	CERAMIC CHIP	0.1uF		25V
R431	1-216-822-11	METAL CHIP	1.2K	5%	1/16W	C761	1-164-230-11	CERAMIC CHIP	220PF	5%	50V
R432	1-216-864-11	METAL CHIP	0	5%	1/16W	C762	1-164-230-11	CERAMIC CHIP	220PF	5%	50V
R441	1-216-821-11	METAL CHIP	1K	5%	1/16W	C763	1-164-230-11	CERAMIC CHIP	220PF	5%	50V
R442	1-216-822-11	METAL CHIP	1.2K	5%	1/16W	C764	1-164-156-11	CERAMIC CHIP	0.1uF		25V
R443	1-216-823-11	METAL CHIP	1.5K	5%	1/16W	C770	1-126-206-11	ELECT CHIP	100uF	20%	6.3V
R450	1-216-845-11	METAL CHIP	100K	5%	1/16W	C781	1-126-206-11	ELECT CHIP	100uF	20%	6.3V
R455	1-216-833-11	METAL CHIP	10K	5%	1/16W	C782	1-164-156-11	CERAMIC CHIP	0.1uF		25V
R456	1-216-829-11	METAL CHIP	4.7K	5%	1/16W	< CONNECTOR >					
R500	1-216-813-11	METAL CHIP	220	5%	1/16W	CN701	1-750-341-11	CONNECTOR, FFC/EPC (ZIF) 18P			
R501	1-216-813-11	METAL CHIP	220	5%	1/16W	CN702	1-784-866-21	CONNECTOR,FFC(LIF(NON-ZIF))14P			
R502	1-216-813-11	METAL CHIP	220	5%	1/16W	* CN703	1-580-055-21	PIN, CONNECTOR (SMD) 2P			
R503	1-216-813-11	METAL CHIP	220	5%	1/16W						
R504	1-216-809-11	METAL CHIP	100	5%	1/16W						
R505	1-216-809-11	METAL CHIP	100	5%	1/16W						
R506	1-216-809-11	METAL CHIP	100	5%	1/16W						
R550	1-216-857-11	METAL CHIP	1M	5%	1/16W						
R551	1-414-760-21	FERRITE	0UH								
R552	1-216-813-11	METAL CHIP	220	5%	1/16W						
R554	1-216-815-11	METAL CHIP	330	5%	1/16W						
R600	1-216-853-11	METAL CHIP	470K	5%	1/16W						

PANEL

Ref. No.	Part No.	Description	Remarks
		< DIODE >	
D751	8-719-051-89	DIODE SML-010VT-T87 (I/Ⓞ)	
		< IC >	
IC781	8-749-013-92	IC GP1UC7X (REMOTE SENSOR)	△
		< TRANSISTOR >	
Q701	8-729-015-76	TRANSISTOR UN5211	
Q751	8-729-015-74	TRANSISTOR UN5111	
		< RESISTOR >	
R702	1-216-825-11	METAL CHIP 2.2K 5% 1/16W	
R713	1-216-829-11	METAL CHIP 4.7K 5% 1/16W	
R726	1-216-841-11	METAL CHIP 47K 5% 1/16W	
R750	1-216-847-11	METAL CHIP 150K 5% 1/16W	
R751	1-216-811-11	METAL CHIP 150 5% 1/16W	
R752	1-216-809-11	METAL CHIP 100 5% 1/16W	
R760	1-216-809-11	METAL CHIP 100 5% 1/16W	
R761	1-216-809-11	METAL CHIP 100 5% 1/16W	
R762	1-216-809-11	METAL CHIP 100 5% 1/16W	
R763	1-216-809-11	METAL CHIP 100 5% 1/16W	
R781	1-216-805-11	METAL CHIP 47 5% 1/16W	
R782	1-216-809-11	METAL CHIP 100 5% 1/16W	
		< SWITCH >	
S701	1-762-875-21	SWITCH, KEYBOARD (●)	
S702	1-762-875-21	SWITCH, KEYBOARD (■/▲)	
S713	1-475-235-21	ENCODER, ROTARY (I◀◀/▶▶I, PUSH ▶▶I)	
S726	1-762-875-21	SWITCH, KEYBOARD (I/Ⓞ)	

Ref. No.	Part No.	Description	Remarks
		ACCESSORIES & PACKING MATERIALS *****	
A-4680-613-A		OVERALL ASSY (PCLK-MN10)	
1-469-089-11		FILTER, CLAMP (FERRITE CORE)(for USB CABLE)(CND,US)	
1-476-295-11		REMOTE COMMANDER(RM-D52M)	
1-476-351-11		ADAPTOR, AC (AC-96NP) (CND,US)	△
1-476-352-11		ADAPTOR, AC (AC-96NP) (AEP,MY,SP)	△
1-476-353-11		ADAPTOR, AC (AC-96NP) (UK)	△
1-500-386-21		FILTER, CLAMP (FERRITE CORE) (for USB CABLE)(AEP,MY,SP,UK)	
1-543-793-11		FILTER, CLAMP (FERRITE CORE)(PCLK-MN10)	
1-574-264-11		CORD, OPTICAL PLUG	
1-757-409-11		CORD, CONNECTION (AUDIO)	
1-757-471-11		CABLE, CONNECTION (USB)	
1-772-866-12		CD-ROM	
4-230-574-31		MANUAL, INSTRUCTION (PCLK-MN10) (ENGLISH/FRENCH/GERMAN/SPANISH/DUTCH/ SWEDISH/ITALIAN/PORTUGUESE/ TRADITIONAL CHINESE)	
4-232-693-11		MANUAL, INSTRUCTION (MDS-PC3)(ENGLISH)	
4-230-661-21		MANUAL, INSTRUCTION (MDS-PC3)(FRENCH)	
4-230-661-31		MANUAL, INSTRUCTION (MDS-PC3)(GERMAN)	
4-230-661-41		MANUAL, INSTRUCTION (MDS-PC3)(SPANISH)	
4-230-661-51		MANUAL, INSTRUCTION (MDS-PC3)(DUTCH)	
4-230-661-61		MANUAL, INSTRUCTION (MDS-PC3)(SWEDISH)	
4-230-661-71		MANUAL, INSTRUCTION (MDS-PC3)(ITALIAN)	
4-230-661-81		MANUAL, INSTRUCTION (MDS-PC3)(PORTUGUESE)	
4-230-661-91		MANUAL, INSTRUCTION (MDS-PC3)(TRADITIONAL CHINESE)	
4-233-452-01		COVER, BATTERY (For RM-D52M)	

MISCELLANEOUS

11	1-757-134-11	WIRE (FLAT TYPE) (13 CORE)	
* 18	1-565-514-11	SOCKET, CONNECTOR 2P	
19	1-792-812-11	WIRE (FLAT TYPE) (27 CORE)	
20	1-792-811-11	WIRE (FLAT TYPE) (23 CORE)	
21	A-4725-377-A	MAIN BOARD, COMPLETE (US)	
21	A-4725-378-A	MAIN BOARD, COMPLETE (CND)	
21	A-4725-379-A	MAIN BOARD, COMPLETE (AEP)	
21	A-4725-380-A	MAIN BOARD, COMPLETE (UK)	
21	A-4725-381-A	MAIN BOARD, COMPLETE (MY,SP)	
351	A-4725-054-A	BD BOARD, COMPLETE	
357	1-678-514-11	FLEXIBLE BOARD	
△ 358	A-4672-541-A	OPTICAL PICK-UP KMS-260B/J1N	
M101	A-4672-898-A	MOTOR ASSY, SPINDLE	
M102	A-4672-900-A	MOTOR ASSY, SLED	
M103	A-4672-975-A	MOTOR ASSY, LOADING	
S102	1-771-957-11	SWITCH, PUSH (2 KEY) (REFLECT/PROTECT SW)	
HR901	1-500-670-12	HEAD, OVER LIGHT	
LCD701	1-804-188-11	LCD MODULE	
LED701	1-804-189-11	LIGHT, LCD BACK	

The components identified by mark △ or dotted line with mark △ are critical for safety. Replace only with part number specified.

Les composants identifiés par une marque △ sont critiques pour la sécurité. Ne les remplacer que par une pièce portant le numéro spécifié.
