

# MDS-M100

## SERVICE MANUAL

**Self Diagnosis**  
Supported model



*US Model  
Canadian Model  
AEP Model  
UK Model  
E Model*

U.S. and foreign patents licensed from Dolby Laboratories Licensing Corporation.

Model Name Using Similar Mechanism	MDS-JE520
MD Mechanism Type	MDM-5A
Optical Pick-up Type	KMS-260A/J1N

### SPECIFICATIONS

<b>System</b>	MiniDisc digital audio system
<b>Disc</b>	MiniDisc
<b>Laser</b>	Semiconductor laser ( $\lambda = 780 \text{ nm}$ ) Emission duration: continuous
<b>Laser output</b>	Less than $44.6 \mu\text{W}^*$  *This output is the value measured at a distance of 200 mm from the objective lens surface on the Optical Pick-up Block with 7 mm aperture.
<b>Laser diode</b>	Material: GaAlAs
<b>Revolutions (CLV)</b>	400 rpm to 900 rpm
<b>Error correction</b>	Advanced Cross Interleave Reed Solomon Code (ACIRC)
<b>Sampling frequency</b>	44.1 kHz
<b>Coding</b>	Adaptive Transform Acoustic Coding (ATRAC)
<b>Modulation system</b>	EFM (Eight-to-Fourteen Modulation)
<b>Number of channels</b>	2 stereo channels
<b>Frequency response</b>	5 to 20,000 Hz $\pm 0.3 \text{ dB}$
<b>Signal-to-noise ratio</b>	Over 98 dB during playback
<b>Wow and flutter</b>	Below measurable limit

#### Inputs

##### LINE (ANALOG) IN

Jack type: phono  
Impedance: 47 kilohms  
Rated input: 500 mVrms  
Minimum input: 125 mVrms

##### DIGITAL IN

Connector type: square optical  
Impedance: 660 nm (optical wave length)

#### Outputs

##### LINE (ANALOG) OUT

Jack type: phono  
Rated output: 2 Vrms (at 50 kilohms)  
Load impedance: Over 10 kilohms

– Continued on next page –



MINIDISC DECK

**SONY**<sup>®</sup>

## General

### Power requirements

Where purchased	Power requirements
U.S.A. and Canada	120 V AC, 60 Hz
U.K. and Continental Europe	220 - 230 V AC, 50/60 Hz
Other countries	110 - 120 or 220 - 240 V AC selectable, 50/60 Hz

Power consumption 15 W

Dimensions (approx.) 355 × 95 × 345 mm (w/h/d) incl. projecting parts and controls

Mass (approx.) 3.7 kg

## Supplied accessories

- Audio connecting cords (2)
- Optical cable (1)
- Remote commander (remote) RM-D30P (1)
- R6 (size-AA) batteries (2)

Design and specifications are subject to change without notice.

## SELF-DIAGNOSIS FUNCTION

The self-diagnosis function consists of error codes for customers which are displayed automatically when errors occur, and error codes which show the error history in the test mode during servicing. For details on how to view error codes for the customer, refer to the following box in the instruction manual. For details on how to check error codes during servicing, refer to the following "Procedure for using the Self-Diagnosis Function (Error History Display Mode)".

### Self-Diagnosis Function

The deck's self-diagnosis function automatically checks the condition of the MD deck when an error occurs, then issues a three-digit code and an error message on the display. If the code and message alternate, find them in the following table and perform the indicated countermeasure. Should the problem persist, consult your nearest Sony dealer.



Three-digit code/Message	Cause/Remedy
C11/Protected	The inserted MD is record-protected. → Take out the MD and close the record-protect slot (page 15).
C13/REC Error	The recording was not made properly. → Set the deck in a stable surface, and repeat the recording procedure.  The inserted MD is dirty (with smudges, fingerprints, etc.), scratched, or substandard in quality. → Replace the disc and repeat the recording procedure.
C13/Disc Error	The deck could not read the TOC on the MD properly. → Take out the MD and insert it again.
C14/Disc Error	The deck could not read the TOC on the MD properly. → Insert another disc. → If possible, erase all the tracks on the MD (page 30).
C71/Din Unlock	The sporadic appearance of this message is caused by the digital signal being recorded. This will not affect the recording.  While recording from a digital component connected through the DIGITAL IN connector, the digital connecting cable was unplugged or the digital component turned off. → Connect the cable or turn the digital component back on.

### PROCEDURE FOR USING THE SELF-DIAGNOSIS FUNCTION (ERROR HISTORY DISPLAY MODE)

Note: Perform the self-diagnosis function in the "error history display mode" in the test mode. The following describes the least required procedure. Be careful not to enter other modes by mistake. If you set other modes accidentally, press the MENU/NO button to exit the mode.

1. While pressing the **◀◀ AMS ▶▶** knob and **■** button, connect the power plug to the outlet, and release the **◀◀ AMS ▶▶** knob and **■** button.
2. Turn the **◀◀ AMS ▶▶** knob and when "[Service]" is displayed, press the **YES** button.
3. Turn the **◀◀ AMS ▶▶** knob to display "ERR DP MODE".
4. Press the **YES** button to set the error history mode and displays "total rec".
5. Select the contents to be displayed or executed using the **◀◀ AMS ▶▶** knob.
6. Press the **◀◀ AMS ▶▶** knob to display or execute the contents selected.
7. Press the **◀◀ AMS ▶▶** knob another time returns to step 4.
8. Press the **MENU/NO** button to display "ERROR DP MODE" and exits the error history mode.
9. To exit the test mode, press the **REPEAT** button. The unit sets into the STANDBY state, the disc is ejected, and the test mode ends.

**Items of Error History Mode Items and Contents**  
**Selecting the Test Mode**

Display	Details of History
total rec	Displays the recording time. Displayed as “r□□□□□h”. The displayed time is the total time the laser is set to the high power state. This is about 1/4 of the actual recording time. The time is displayed in decimal digits from 0h to 65535h.
total play	Displays the play time. Displayed as “p□□□□□h”. The time displayed is the total actual play time. Pauses are not counted. The time is displayed in decimal digits from 0h to 65535h.
retry err	Displays the total number of retries during recording and number of retry errors during play. Displayed as “r□□ p□□”. “r” indicates the retries during recording while “p” indicates the retry errors during play. The number of retries and retry errors are displayed in hexadecimal digits from 00 to FF.
total err	Displays the total number of errors. Displayed as “total □□”. The number of errors is displayed in hexadecimal digits from 00 to FF.
err history	Displays the 10 latest errors. Displayed as “0□ E@@”. □ indicates the history number. The smaller the number, the more recent is the error. (00 is the latest). @@ indicates the error code. Refer to the following table for the details. The error history can be switched by turning the  knob.
er refresh	Mode which erases the “retry err”, “total err”, and “err history” histories. When returning the unit to the customer after completing repairs, perform this to erase the past error history. After pressing the  button and “er refresh?” is displayed, press the <b>YES</b> button to erase the history. “Complete!” will be displayed momentarily. Be sure to check the following when this mode has been executed. <ul style="list-style-type: none"> <li>• The data has been erased.</li> <li>• The mechanism operates normally when recording and play are performed.</li> </ul>
tm refresh	Mode which erases the “total rec” and “total play” histories. These histories serve as approximate indications of when to replace the optical pickup. If the optical pickup has been replaced, perform this operation and erase the history. After pressing the  button and “tm refresh?” is displayed, press the <b>YES</b> button to erase the history. “Complete!” will be displayed momentarily. Be sure to check the following when this mode has been executed. <ul style="list-style-type: none"> <li>• The data has been erased.</li> <li>• The mechanism operates normally when recording and play are performed.</li> </ul>

**Table of Error Codes**

Error Code	Details of Error	Error Code	Details of Error
E00	No error	E05	FOK has deviated
E01	Disc error. PTOC cannot be read (DISC ejected)	E06	Cannot focus (Servo has deviated)
		E07	Recording retry
E02	Disc error. UTOC error (DISC not ejected)	E08	Recording retry error
		E09	Playback retry error (Access error)
E03	Loading error		
E04	Address cannot be read (Servo has deviated)	E0A	Playback retry error (C2 error)

# SECTION 1 SERVICING NOTES

## TABLE OF CONTENTS

<b>SELF-DIAGNOSIS FUNCTION</b> .....	2
<b>1. SERVICING NOTES</b> .....	4
<b>2. GENERAL</b> .....	11
<b>3. DISASSEMBLY</b> .....	12
<b>4. TEST MODE</b> .....	16
<b>5. ELECTRICAL ADJUSTMENTS</b> .....	21
<b>6. DIAGRAMS</b>	
6-1. IC Pin Function Description .....	30
6-2. Block Diagram – SERVO Section – .....	37
6-3. Block Diagram – MAIN Section – .....	39
6-4. Note for Printed Wiring Boards and Schematic Diagrams .....	42
6-5. Printed Wiring Board – BD Board – .....	43
6-6. Schematic Diagram – BD Board (1/2) – .....	45
6-7. Schematic Diagram – BD Board (2/2) – .....	47
6-8. Schematic Diagram – SW Board – .....	49
6-9. Printed Wiring Board – SW Board – .....	49
6-10. Printed Wiring Boards – TRANS Board – .....	53
6-11. Printed Wiring Board – MAIN Board – .....	55
6-12. Schematic Diagram – MAIN Board (1/2) – .....	57
6-13. Schematic Diagram – MAIN Board (2/2), TRANS Board – .....	59
6-14. Printed Wiring Boards – PANEL/PANEL 2 Boards – ...	61
6-15. Schematic Diagram – PANEL/PANEL 2 Boards – .....	63
<b>7. EXPLODED VIEWS</b> .....	66
<b>8. ELECTRICAL PARTS LIST</b> .....	70

### SAFETY CHECK-OUT

After correcting the original service problem, perform the following safety check before releasing the set to the customer: Check the antenna terminals, metal trim, “metallized” knobs, screws, and all other exposed metal parts for AC leakage. Check leakage as described below.

### LEAKAGE TEST

The AC leakage from any exposed metal part to earth ground and from all exposed metal parts to any exposed metal part having a return to chassis, must not exceed 0.5 mA (500 microampers). Leakage current can be measured by any one of three methods.

1. A commercial leakage tester, such as the Simpson 229 or RCA WT-540A. Follow the manufacturers’ instructions to use these instruments.
2. A battery-operated AC milliammeter. The Data Precision 245 digital multimeter is suitable for this job.
3. Measuring the voltage drop across a resistor by means of a VOM or battery-operated AC voltmeter. The “limit” indication is 0.75 V, so analog meters must have an accurate low-voltage scale. The Simpson 250 and Sanwa SH-63Trd are examples of a passive VOM that is suitable. Nearly all battery operated digital multimeters that have a 2 V AC range are suitable. (See Fig. A)

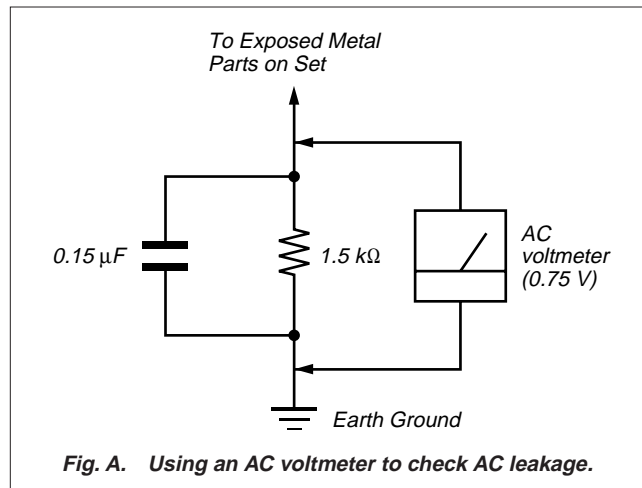

### MODEL IDENTIFICATION

— BACK PANEL —

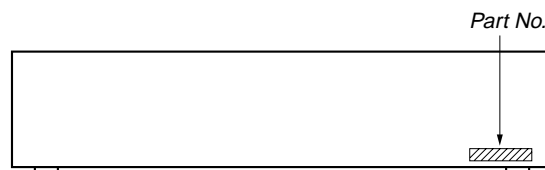

MODEL	Part No.
US model	4-216-840-0□
Canadian model	4-216-840-1□
Singapore model	4-216-840-2□
AEP model	4-216-840-3□
UK model	4-216-840-4□

### CAUTION

Danger of explosion if battery is incorrectly replaced.  
Replace only with the same or equivalent type recommended by the manufacturer.  
Discard used batteries according to the manufacturer's instructions.

### ADVARSEL!

Lithiumbatteri-Eksplosionsfare ved fejlagtig håndtering.  
Udskiftning må kun ske med batteri  
af samme fabrikat og type.  
Levér det brugte batteri tilbage til leverandøren.

### ADVARSEL

Eksplosjonsfare ved feilaktig skifte av batteri.  
Benytt samme batteritype eller en tilsvarende type  
anbefalt av apparatfabrikanten.  
Brukte batterier kasseres i henhold til fabrikantens  
instruksjoner.

### WARNING

Explosionsfara vid felaktigt batteribyte.  
Använd samma batterityp eller en likvärdig typ som  
rekommenderas av apparattillverkaren.  
Kassera använt batteri enligt gällande föreskrifter.

### VAROITUS

Paristo voi räjähtää, jos se on virheellisesti asennettu.  
Vaihda paristo ainoastaan laitevalmistajan suosittelemaan tyyppiin.  
Hävitä käytetty paristo valmistajan ohjeiden mukaisesti.

### SAFETY-RELATED COMPONENT WARNING!!

COMPONENTS IDENTIFIED BY MARK  $\triangle$  OR DOTTED LINE WITH MARK  $\triangle$  ON THE SCHEMATIC DIAGRAMS AND IN THE PARTS LIST ARE CRITICAL TO SAFE OPERATION. REPLACE THESE COMPONENTS WITH SONY PARTS WHOSE PART NUMBERS APPEAR AS SHOWN IN THIS MANUAL OR IN SUPPLEMENTS PUBLISHED BY SONY.

Laser component in this product is capable of emitting radiation exceeding the limit for Class 1.

CLASS 1 LASER PRODUCT  
LUOKAN 1 LASERLAITE  
KLASS 1 LASERAPPARAT

This appliance is classified as a CLASS 1 LASER product. The CLASS 1 LASER PRODUCT MARKING is located on the rear exterior.

CAUTION : INVISIBLE LASER RADIATION WHEN OPEN AND INTERLOCKS DEFEATED. AVOID EXPOSURE TO BEAM.  
ADVARSEL : USYNLIG LASERSTRÅLING VED ÅBNING NÅR SIKKERHEDSafbrydere er ude af funktion. undgå udsættelse for stråling.  
VORSICHT : UNSICHTBARE LASERSTRAHLUNG, WENN ABDECKUNG GEÖFFNET UND SICHERHEITSVERRIEGELUNG ÜBERBRÜCKT. NICHT DEM STRAHL AUSSETZEN.  
VARO! : AVATTAESSA JA SUOJALUKITUS OHITETTAESSA OLET ALT-TIINA NÄKYMÄTTÖMÄLLE LASERSÄTEILYLLE. ÄLÄ KATSO SÄTEESEEN.  
VARNING : OSYNLIG LASERSTRÅLING NÅR DENNA DEL ÅR ÖPPNAD OCH SPÄRREN ÅR URKOPPLAD. BETRAKTA EJ STRÅLEN.  
ADVERSEL : USYNLIG LASERSTRÅLING NÅR DEKSEL ÅPNES OG SIKKERHEDSLÅS BRYTES. UNNGÅ EKSPONERING FOR STRÅLEN.  
VIGYAZAT! : A BURKOLAT NYITÁSAKOR LÁTHATATLAN LÉZERSUGÁRVESZÉLY! KERÜLJE A BESUGÁRZÁST!

This caution label is located inside the unit.

### CAUTION

Use of controls or adjustments or performance of procedures other than those specified herein may result in hazardous radiation exposure.

### Flexible Circuit Board Repairing

- Keep the temperature of the soldering iron around 270 °C during repairing.
- Do not touch the soldering iron on the same conductor of the circuit board (within 3 times).
- Be careful not to apply force on the conductor when soldering or unsoldering.

### Notes on chip component replacement

- Never reuse a disconnected chip component.
- Notice that the minus side of a tantalum capacitor may be damaged by heat.

### ATTENTION AU COMPOSANT AYANT RAPPORT À LA SÉCURITÉ!

LES COMPOSANTS IDENTIFIÉS PAR UNE MARQUE  $\triangle$  SUR LES DIAGRAMMES SCHÉMATIQUES ET LA LISTE DES PIÈCES SONT CRITIQUES POUR LA SÉCURITÉ DE FONCTIONNEMENT. NE REMPLACER CES COMPOSANTS QUE PAR DES PIÈCES SONY DONT LES NUMÉROS SONT DONNÉS DANS CE MANUEL OU DANS LES SUPPLÉMENTS PUBLIÉS PAR SONY.

## JIG FOR CHECKING BD BOARD WAVEFORM

The special jig (J-2501-149-A) is useful for checking the waveform of the BD board. The names of terminals and the checking items to be performed are shown as follows.

GND : Ground

I+3V : For measuring IOP (Check the deterioration of the optical pick-up laser)

IOP : For measuring IOP (Check the deterioration of the optical pick-up laser)

TEO : TRK error signal (Traverse adjustment)

VC : Reference level for checking the signal

RF : RF signal (Check jitter)

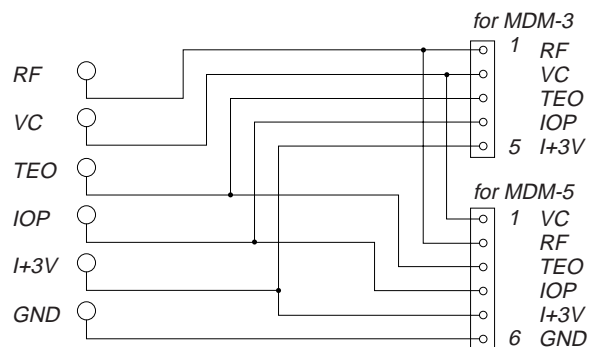
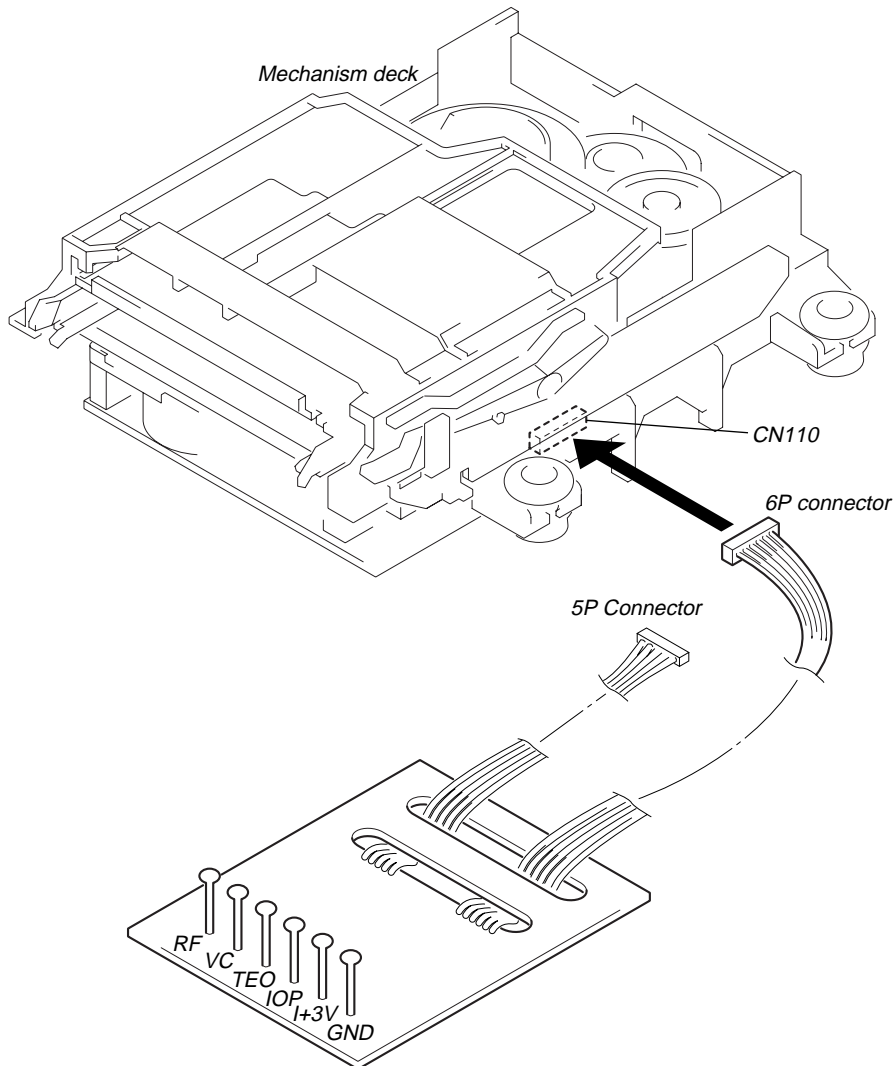

## IOP DATA RECORDING AND DISPLAY WHEN OPTICAL PICK-UP AND NON-VOLATILE MEMORY (IC171 OF BD BOARD) ARE REPLACED

The IOP value labeled on the optical pick-up can be recorded in the non-volatile memory. By recording the value, it will eliminate the need to look at the value on the label of the optical pick-up. When replacing the optical pick-up or non-volatile memory (IC171 of BD board), record the IOP value on the optical pick-up according to the following procedure.

### Record Procedure:

1. While pressing the **◀◀ AMS ▶▶** knob and **■** button, connect the power plug to the outlet, and release the **◀◀ AMS ▶▶** knob and **■** button.
2. Turn the **◀◀ AMS ▶▶** knob to display “[Service]”, and press the **YES** button.
3. Turn the **◀◀ AMS ▶▶** knob to display “Iop Write” (C28), and press the **YES** button.
4. The display becomes “Ref=@@.@” (@ is an arbitrary number) and the numbers which can be changed will blink.
5. Input the IOP value written on the optical pick-up.  
To select the number : Turn the **◀◀ AMS ▶▶** knob.  
To select the digit : Press the **◀◀ AMS ▶▶** knob.
6. When the **YES** button is pressed, the display becomes “Measu=@@@.@” (@ is an arbitrary number).
7. As the adjustment results are recorded for the 6 value. Leave it as it is and press the **YES** button.
8. “Complete!” will be displayed momentarily. The value will be recorded in the non-volatile memory and the display will become “Iop Write”.
9. Press the **REPEAT** button to complete.

### Display Procedure:

1. While pressing the **◀◀ AMS ▶▶** knob and **■** button, connect the power plug to the outlet, and release the **◀◀ AMS ▶▶** knob and **■** button.
2. Turn th **◀◀ AMS ▶▶** knob to display “[Service]”, and press the **YES** button.
3. Turn the **◀◀ AMS ▶▶** knob to display “Iop Read” (C27).
4. “@@.@/##.#” is displayed and the recorded contents are displayed.  
@@.@ : indicates the IOP value labeled on the optical pick-up.  
##.# : indicates the IOP value after adjustment
5. To end, press the **◀◀ AMS ▶▶** knob or **MENU/NO** button to display “Iop Read”. Then press the **REPEAT** button.

## CHECKS PRIOR TO PARTS REPLACEMENT AND ADJUSTMENTS

Before performing repairs, perform the following checks to determine the faulty locations up to a certain extent. Details of the procedures are described in “5 Electrical Adjustments”.

	Criteria for Determination (Unsatisfactory if specified value is not satisfied)	Measure if unsatisfactory:
Laser power check (6-2 : See page 23)	<ul style="list-style-type: none"> <li>0.9 mW power Specified value : 0.84 to 0.92 mW</li> <li>7.0 mW power Specified value : 6.8 to 7.2 mW</li> </ul>	<ul style="list-style-type: none"> <li>Clean the optical pick-up</li> <li>Adjust again</li> <li>Replace the optical pick-up</li> </ul>
	<ul style="list-style-type: none"> <li>Iop (at 7mW)</li> <li>Labeled on the optical pickup Iop value <math>\pm</math> 10mA</li> </ul>	<ul style="list-style-type: none"> <li>Replace the optical pick-up</li> </ul>
Traverse check (6-3 : See page 23)	<ul style="list-style-type: none"> <li>Traverse waveform Specified value : Below 10% offset</li> </ul>	<ul style="list-style-type: none"> <li>Replace the optical pick-up</li> </ul>
Focus bias check (6-4 : See page 24)	<ul style="list-style-type: none"> <li>Error rate check Specified value : For points a, b, and c C1 error : About 200 AD error : Above 00</li> </ul>	<ul style="list-style-type: none"> <li>Replace the optical pick-up</li> </ul>
C PLAY check (6-5 : See page 24)	<ul style="list-style-type: none"> <li>Error rate check Specified value:               <ol style="list-style-type: none"> <li>When using test disc (MDW-74/AU-1) C1 error : Below 80 AD error : Below 2</li> <li>When using check disc (TDYS-1) C1 error : Below 50</li> </ol> </li> </ul>	<ul style="list-style-type: none"> <li>Replace the optical pick-up</li> </ul>
Self-recording/playback check (6-6 : See page 24)	<ul style="list-style-type: none"> <li>CPLAY error rate check Specified value: C1 error : Below 80 AD error : Below 2</li> </ul>	If always unsatisfactory: <ul style="list-style-type: none"> <li>Replace the overwrite head</li> <li>Check for disconnection of the circuits around the overwrite head</li> </ul>
		If occasionally unsatisfactory: <ul style="list-style-type: none"> <li>Check if the overwrite head is distorted</li> <li>Check the mechanism around the sled</li> </ul>
Temperature compensation offset check (6-1 : See page 23)	<ul style="list-style-type: none"> <li>Unsatisfactory if displayed as T=@@ (##) [NG” NG (@@, ## are both arbitrary numbers)</li> </ul>	<ul style="list-style-type: none"> <li>Check for disconnection of the circuits around D101 (BD board)</li> <li>Check the signals around IC101, IC121, CN102, CN103 (BD board)</li> </ul>

### Note:

The criteria for determination above is intended merely to determine if satisfactory or not, and does not serve as the specified value for adjustments. When performing adjustments, use the specified values for adjustments.



## RETRY CAUSE DISPLAY MODE

- In this test mode, the causes for retry of the unit during recording can be displayed on the fluorescent indicator tube. During playback, the “track mode” for obtaining track information will be set. This is useful for locating the faulty part of the unit.
- The following will be displayed :
  - During recording and stop: Retry cause, number of retries, and number of retry errors.
  - During playback : Information such as type of disc played, part played, copyright.
 These are displayed in hexadecimal.

### Precedure:

- Load a recordable disc whose contents can be erased into the unit.
- Press the **MENU/NO** button. When “Edit Menu” is displayed on the fluorescent indicator tube, turn the **◀◀ AMS ▶▶** knob to display “All Erase?”.
- Press the **YES** button. (Or press the **◀◀ AMS ▶▶** knob)
- When “All Erase??” is displayed on the fluorescent indicator tube, the music calendar number blinks.
- Press the **YES** button to display “Complete!!”, and press the **■** button immediately. Wait for about 15 seconds while pressing the button. (The **◀◀ AMS ▶▶** knob can be pressed instead of the **YES** button for the same results.)
- When the “TOC” displayed on the fluorescent display tube goes off, release the **■** button.
- Press the **● REC** button to start recording. Then press the **■** button and start recording.
- To check the “track mode”, press the **▷** button to start play.
- To exit the test mode, press the **I/⏻** button, and turn OFF the power. When “TOC” disappears, disconnect the power plug from the outlet.

**Fig. 1 Reading the Test Mode Display (During recording and stop)**

RTs@@c##e\*\*

Fluorescent display tube display

@@ : Cause of retry  
 ## : Number of retries  
 \*\* : Number of retry errors

**Fig. 2 Reading the Test Mode Display (During playback)**

@@#####\$\$

Fluorescent display tube display

@@ : Parts No. (name of area named on TOC)  
 ## : Cluster } Address  
 \*\* : Sector }  
 \$\$ : Track mode (Track information such as copy-right information of each part)

### Reading the Retry Cause Display

Hexadecimal	Higher Bits				Lower Bits				Hexa-decimal	Cause of Retry	Occurring conditions
	8	4	2	1	8	4	2	1			
Bit	b7	b6	b5	b4	b3	b2	b1	b0			
Binary	0	0	0	0	0	0	0	1	01	shock	When track jump (shock) is detected
	0	0	0	0	0	0	1	0	02	ader5	When ADER was counted more than five times continuously
	0	0	0	0	0	1	0	0	04	Discontinuous address	When ADIP address is not continuous
	0	0	0	0	1	0	0	0	08	DIN unlock	When DIN unlock is detected
	0	0	0	1	0	0	0	0	10	FCS incorrect	When not in focus
	0	0	1	0	0	0	0	0	20	IVR rec error	When ABCD signal level exceeds the specified range
	0	1	0	0	0	0	0	0	40	CLV unlock	When CLV is unlocked
	1	0	0	0	0	0	0	0	80	Access fault	When access operation is not performed normally

### Reading the Display:

Convert the hexadecimal display into binary display. If more than two causes, they will be added.

### Example

When 42 is displayed:  
 Higher bit: 4 = 0100 → b6  
 Lower bit : 2 = 0010 → b1  
 In this case, the retry cause is combined of “CLV unlock” and “ader5”.

When A2 is displayed:  
 Higher bit: A = 1010 → b7+b5  
 Lower bit : 2 = 0010 → b1  
 The retry cause in this case is combined of “access fault”, “IVR rec error”, and “ader5”.

### Reading the Retry Cause Display

Hexadecimal	Higher Bits				Lower Bits				Hexa- decimal	Details	
	8	4	2	1	8	4	2	1		When 0	When 1
Bit	b7	b6	b5	b4	b3	b2	b1	b0			
Binary	0	0	0	0	0	0	0	1	01	Emphasis OFF	Emphasis ON
	0	0	0	0	0	0	1	0	02	Monaural	Stereo
	0	0	0	0	0	1	0	0	04	This is 2-bit display. Normally 01. 01:Normal audio. Others:Invalid	
	0	0	0	0	1	0	0	0	08		
	0	0	0	1	0	0	0	0	10	Audio (Normal)	Invalid
	0	0	1	0	0	0	0	0	20	Original	Digital copy
	0	1	0	0	0	0	0	0	40	Copyright	No copyright
	1	0	0	0	0	0	0	0	80	Write prohibited	Write allowed

### Reading the Display:

Convert the hexadecimal display into binary display. If more than two causes, they will be added.

Example When 84 is displayed:

Higher bit: 8 = 1000 → b7

Lower bit : 4 = 0100 → b2

In this case, as b2 and b7 are 1 and others are 0, it can be determined that the retry cause is combined of “emphasis OFF”, “monaural”, “original”, “copyright exists”, and “write allowed”.

Example When 07 is displayed:

Higher bit: 0 = 1000 → All 0

Lower bit : 7 = 0111 → b0+b1+b2

In this case, as b0, b1, and b2 are 1 and others are 0, it can be determined that the retry cause is combined of “emphasis ON”, “stereo”, “original”, “copyright exists”, and “write prohibited”.

### Hexadecimal → Binary Conversion Table

Hexadecimal	Binary	Hexadecimal	Binary
0	0000	8	1000
1	0001	9	1001
2	0010	A	1010
3	0011	B	1011
4	0100	C	1100
5	0101	D	1101
6	0110	E	1110
7	0111	F	1111

## SECTION 2 GENERAL

This section is extracted from instruction manual.

### Front Panel Parts Description

- 1** I/⏻ (power) switch (14, 21)  
Press to turn the deck on. When you turn the deck on, the switch indicator changes from red to green. When you press the switch again, the deck turns off and the indicator changes to red.
- 2** SCROLL button (12)  
Press to scroll the name of a track or MD.
- 3** LEVEL/DISPLAY/CHAR button (12, 16, 25, 33)  
• Press during recording pause to adjust the recording level (in the case of analog recording).  
• Press when the deck is stopped to display disc information or the contents of a program.  
• Press during recording to display information on the track being recorded.  
• Press during play to display information on the current track.  
• Press while editing an MD to select the type of characters to be input.
- 4** Display window (11, 12)  
Shows various information.
- 5** MD insertion slot (14, 21)  
Insert the MD as illustrated below.

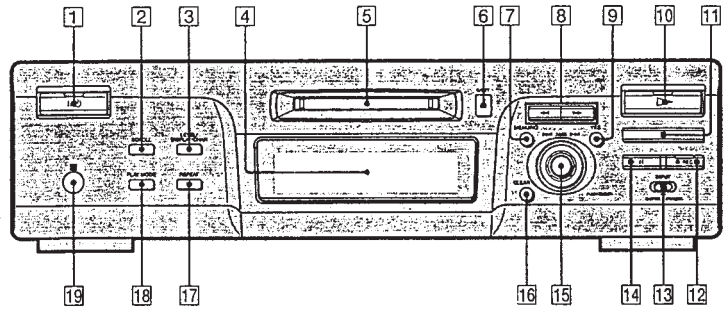
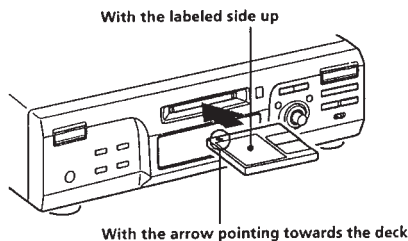

- 6** EJECT button (15, 21)  
Press to eject the MD.
- 7** MENU/NO button (14, 29, 38)  
Press to display "Edit Menu" or "Setup Menu."
- 8** ◀▶ buttons (23, 25, 30, 33)  
Press to locate a portion within a track, change the contents of a program, or change the input character.
- 9** YES button (14, 25, 29, 38)  
Press to carry out the selected operation.
- 10** ▷ button (15, 21)  
Press to start play.
- 11** ■ button (15, 21, 29)  
Press to stop play or recording or cancel the selected operation.
- 12** ●REC button (15-17)  
Press to record on the MD, monitor the input signal, or mark track numbers.
- 13** INPUT switch (14)  
Use to select the input jack (or connector) of the program source to be recorded.
- 14** || button (15, 21)  
Press to pause play or recording. Press again to resume play or recording.
- 15** AMS control (14-16, 21, 25, 29, 33, 38)  
Turn to locate tracks, adjust the recording level, select the input characters, or select a menu item.
- 16** CLEAR button (26, 44)  
Press to cancel the selection.
- 17** REPEAT button (23, 24)  
Press to play tracks repeatedly.
- 18** PLAY MODE button (24)  
Press to select Shuffle Play or Program Play.
- 19** Remote sensor (4)  
Point the remote towards this window (■) for remote operations.

### Remote Parts Description

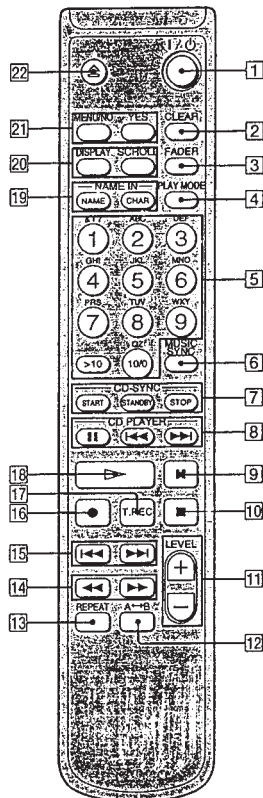

- 1** I/⏻ (power) switch (14, 21)  
Press to turn the deck on. When you turn the deck on, the I/⏻ switch indicator on the deck changes from red to green. When you press the switch again, the deck turns off and the indicator changes to red.
- 2** CLEAR button (26, 34)  
Press to cancel the selection.
- 3** FADER button (37)  
Press to perform Fade-in Play/Recording or Fade-out Play/Recording.
- 4** PLAY MODE button (24)  
Press to select Shuffle Play or Program Play.
- 5** Letter/number buttons (22, 34)  
Press to input letters or numbers.
- 6** MUSIC SYNC button (19)  
Press to start Music Synchro-recording.
- 7** CD-SYNC START button (19)  
Press to start CD Synchro-recording.
- 8** CD-SYNC STANDBY button (19)  
Press to enter standby for CD Synchro-recording.
- 9** CD-SYNC STOP button (20)  
Press to stop CD Synchro-recording.
- 10** CD PLAYER || button (20)  
Press to pause the CD play. Press again to resume CD play.
- 11** CD PLAYER ◀▶ buttons (20)  
Press to locate tracks on the CD.
- 12** LEVEL +/- buttons (16)  
Press to adjust the recording level during analog recording.
- 13** ■ button (15, 21, 29)  
Press to stop play, stop recording, or cancel the selected operation.
- 14** ▶ button (15, 21)  
Press to start play.
- 15** ◀▶ buttons (23, 25, 30, 34)  
Press to locate a portion within a track, change the contents of a program, or shift the cursor to the right.
- 16** ● button (15-17)  
Press to record on the MD, monitor the input signal, or mark track numbers.
- 17** T.REC button (18)  
Press to start Time Machine Recording.
- 18** ▷ button (15, 21)  
Press to start play.
- 19** NAME button (34)  
Press to add the name or change the name of a track or MD.
- 20** CHAR button (34)  
Press to select the type of characters to be input.
- 21** DISPLAY button (12, 16, 25)  
Press to select the information to be displayed in the window.
- 22** SCROLL button (12)  
Press to scroll the name of a track or MD.
- 23** MENU/NO button (14, 29, 38)  
Press to display "Edit Menu" or "Setup Menu."
- 24** YES button (14, 25, 29, 38)  
Press to carry out the selected operation.
- 25** EJECT button (15, 21)  
Press to eject the MD.
- 26** A↔B button (24)  
Press to select Repeat A-B Play.
- 27** REPEAT button (23, 24)  
Press to play tracks repeatedly.

## SECTION 3 DISASSEMBLY

**Note:** Follow the disassembly procedure in the numerical order given.

### COVER

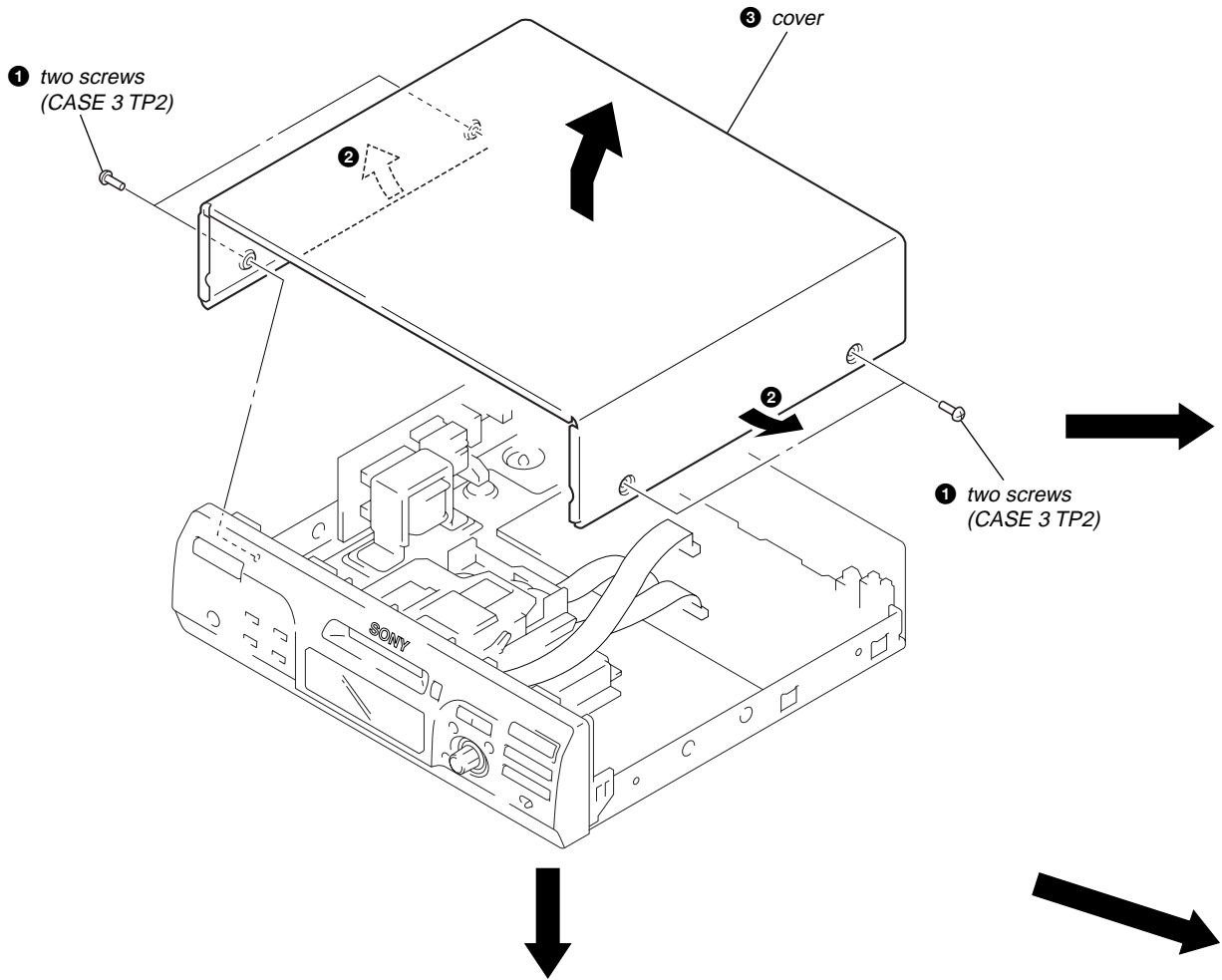

### FRONT PANEL SECTION

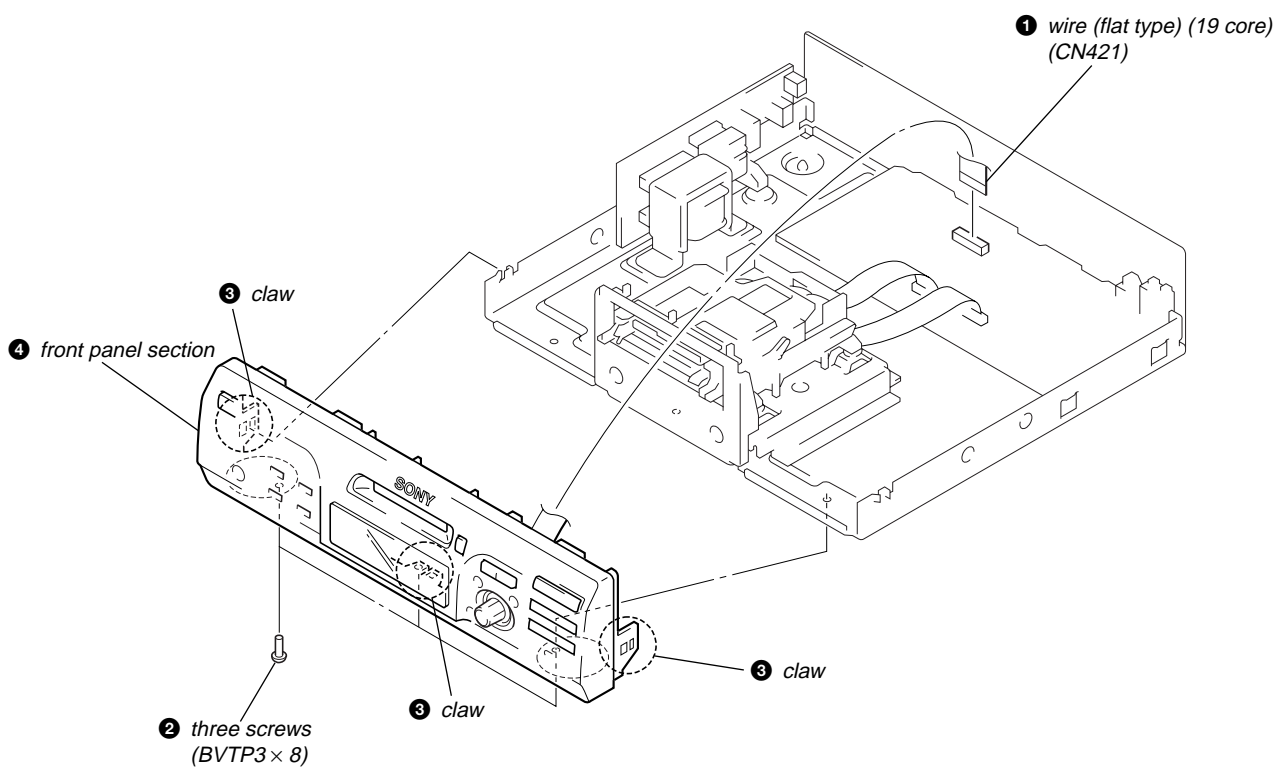

## MAIN BOARD

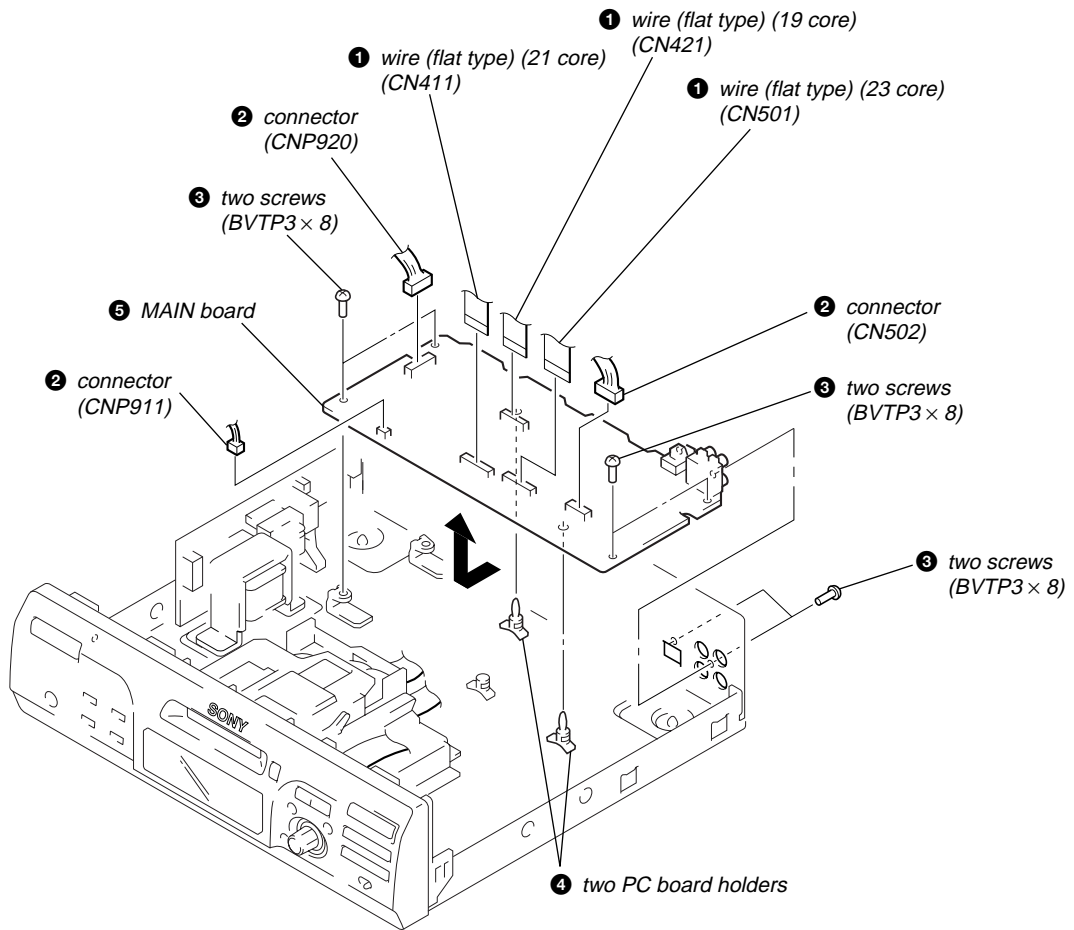

## MECHANISM DECK SECTION (MDM-5A)

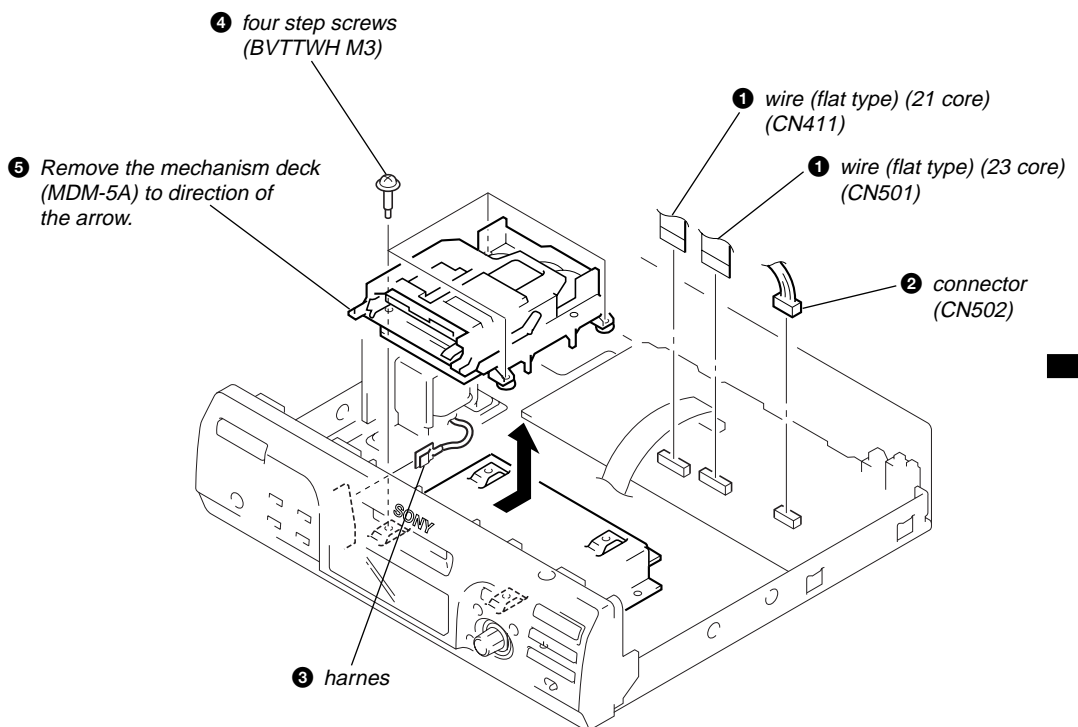

## SLIDER (CAM)

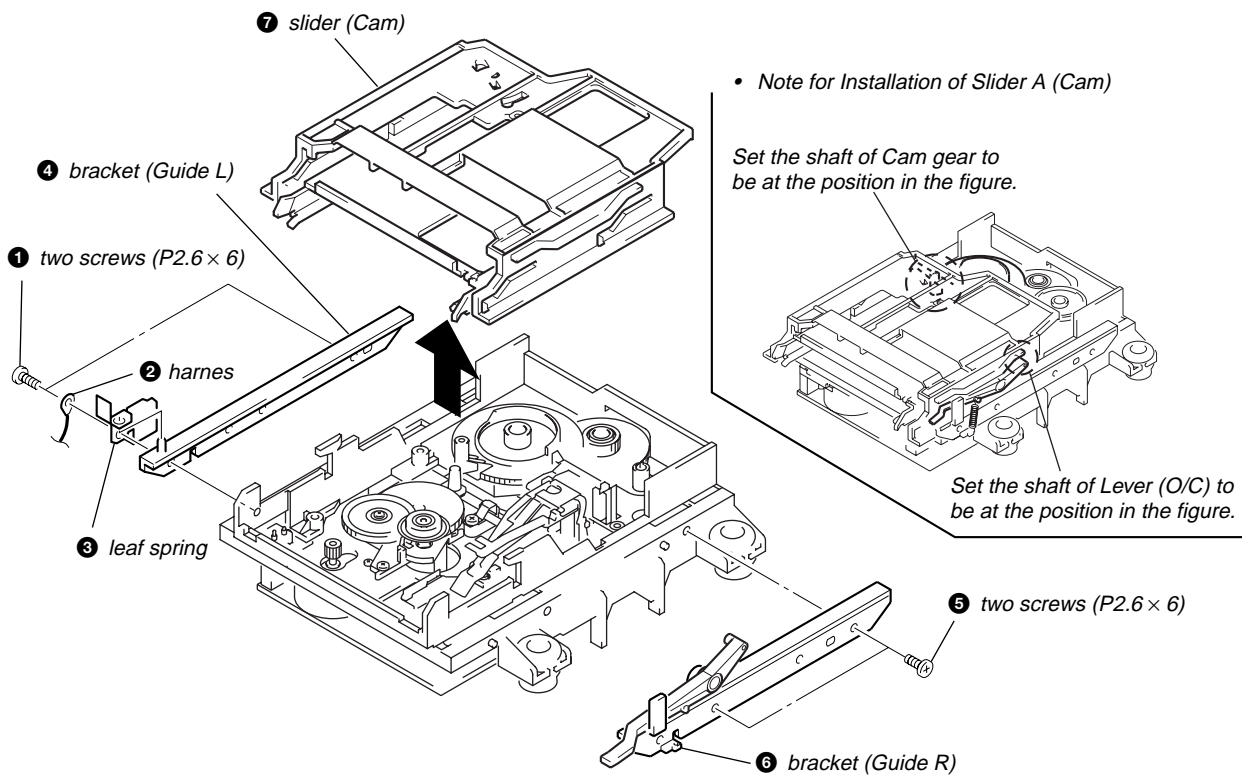

## BASE UNIT (MBU-5A), BD BOARD

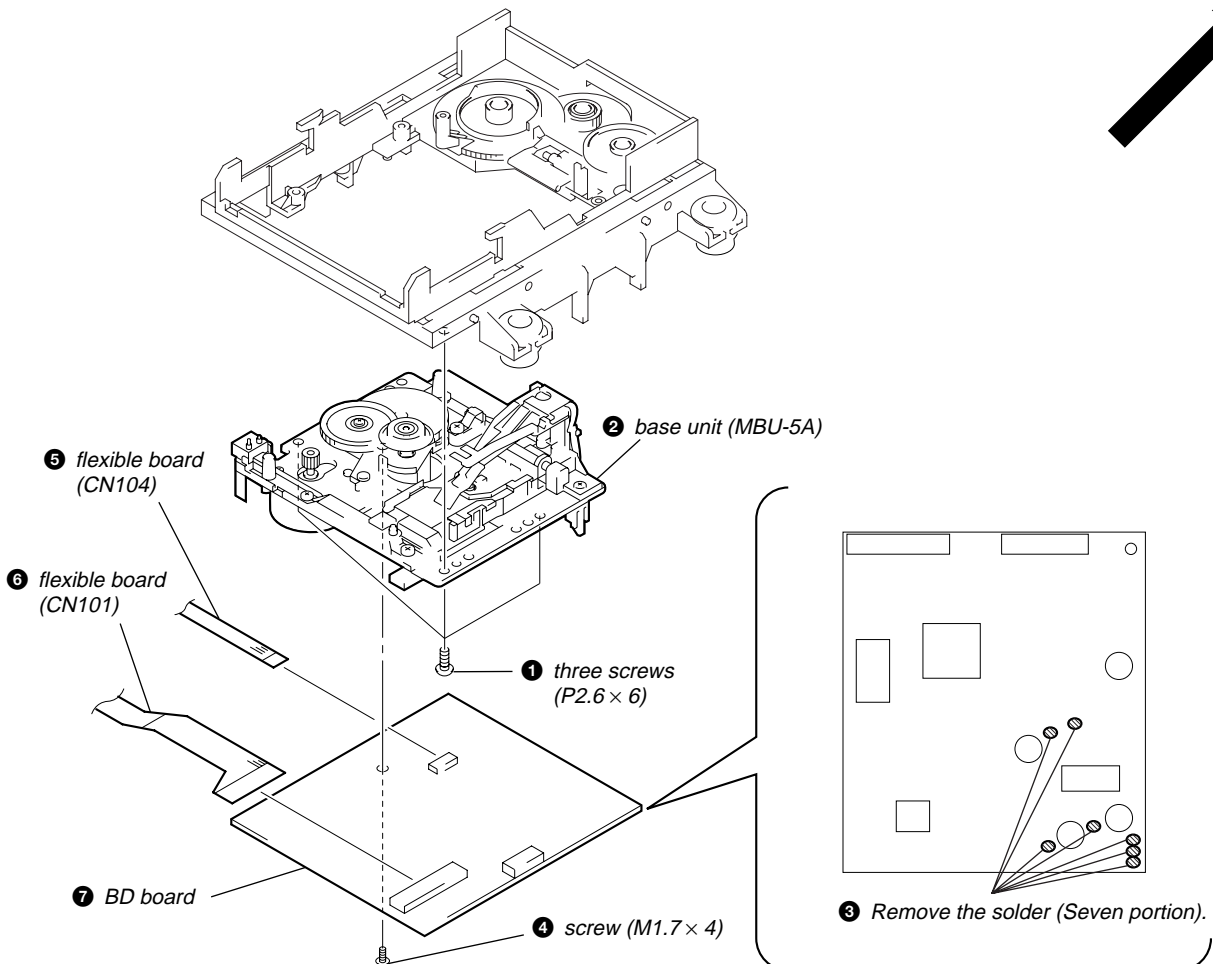

**SW BOARD, LOADING MOTOR (M103)**

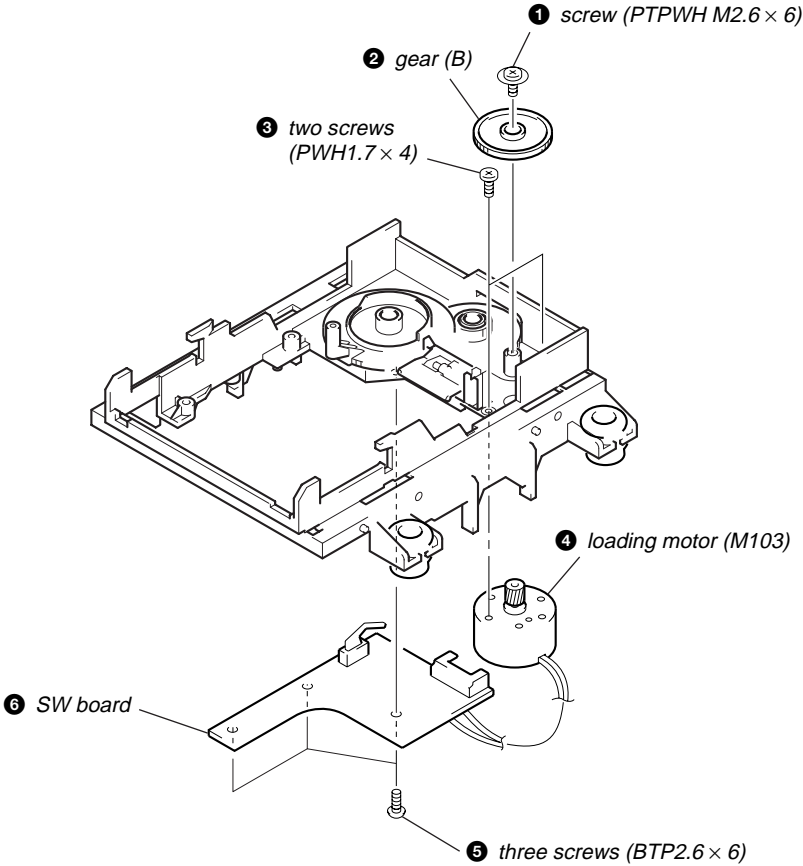

# SECTION 4 TEST MODE

## 1. PRECAUTIONS FOR USE OF TEST MODE

- As loading related operations will be performed regardless of the test mode operations being performed, be sure to check that the disc is stopped before setting and removing it.  
Even if the **[EJECT]** button is pressed while the disc is rotating during continuous playback, continuous recording, etc., the disc will not stop rotating.  
Therefore, it will be ejected while rotating.  
Be sure to press the **[EJECT]** button after pressing the **[MENU/NO]** button and the rotation of disc is stopped.

### 1-1. Recording laser emission mode and operating buttons

- Continuous recording mode (CREC MODE)
- Laser power check mode (LDPWR CHECK)
- Laser power adjustment mode (LDPWR ADJUST)
- Traverse (MO) check (EF MO CHECK)
- Traverse (MO) adjustment (EF MO ADJUST)
- When pressing the **[REC]** button.

## 2. SETTING THE TEST MODE

The following are two methods of entering the test mode.

**Procedure 1:** While pressing the **[AMS]** knob and **[STOP]** button, connect the power plug to an outlet, and release the **[AMS]** knob and **[STOP]** button.

When the test mode is set, “[Check]” will be displayed. Turn the **[AMS]** knob switches between the following four groups; ...↔ [Check] ↔ [Adjust] ↔ [Service] ↔ [Develop] ↔ ...

**Procedure 2:** While pressing the **[AMS]** knob, connect the power plug to the outlet and release the **[AMS]** knob.  
When the test mode is set, “TEMP CHECK” will be displayed. By setting the test mode using this method, only the “Check” group of method 1 can be executed.

## 3. EXITING THE TEST MODE

Press the **[REPEAT]** button. The disc is ejected when loaded, and “Standby” display blinks, and the STANDBY state is set.

## 4. BASIC OPERATIONS OF THE TEST MODE

All operations are performed using the **[AMS]** knob, **[YES]** button, and **[MENU/NO]** button.

The functions of these buttons are as follows.

Function name	Function
<b>[AMS]</b> knob	Changes parameters and modes
<b>[YES]</b> button	Proceeds onto the next step. Finalizes input.
<b>[MENU/NO]</b> button	Returns to previous step. Stops operations.



## 5. SELECTING THE TEST MODE

There are 31 types of test modes as shown below. The groups can be switched by turn the **◀◀ AMS ▶▶** knob. After selecting the group to be used, press the **[YES]** button. After setting a certain group, turn the **◀◀ AMS ▶▶** knob switches between these modes. Refer to “Group” in the table for details selected.

All items used for servicing can be treated using group S. So be carefully not to enter other groups by mistake.

Display	No.	Contents	Mark	Group (*)
TEMP CHECK	C01	Temperature compensation offset check		C S
LDPWR CHECK	C02	Laser power check		C S
EF MO CHECK	C03	Traverse (MO) check		C S
EF CD CHECK	C04	Traverse (CD) check		C S
FBIAS CHECK	C05	Focus bias check		C S
ScurveCHECK	C06	S letter check	(X)	C
VERIFYMODE	C07	Non-volatile memory check	(X)	C
DETRK CHECK	C08	Detrack check	(X)	C
TEMP ADJUST	C09	Temperature compensation offset adjustment		A S
LDPWR ADJUST	C10	Laser power adjustment		A S
EF MO ADJUST	C11	Traverse (MO) adjustment		A S
EF CD ADJUST	C12	Traverse (CD) adjustment		A S
FBIAS ADJUST	C13	Focus bias adjustment		A S
EEP MODE	C14	Non-volatile memory control	(X) (!)	D
Impossible	C15	Command transmission	(X)	D
Impossible	C16	Status display	(X)	D
ERR DP MODE	C17	Error history display, clear		S
Impossible	C18	Sled check	(X)	D
Impossible	C19	Access check	(X)	D
Impossible	C20	Outermost circumference check	(X)	D
Impossible	C21	Head position check	(X)	D
Impossible	C22	Same functions as CPLAY MODE	(X)	D
Impossible	C23	Same functions as CREC MODE	(X)	D
ADJ CLEAR	C24	Initialization of non-volatile memory of adjustment value		A S
AG Set (MO)	C25	Auto gain output level adjustment (MO)		A S
AG Set (CD)	C26	Auto gain output level adjustment (CD)		A S
Iop Read	C27	IOP data display		C S
Iop Write	C28	IOP data write		A S
S40 *****	C29	Microprocessing version display		C S
CPLAY MODE	C30	Continuous play mode		C A S D
CREC MODE	C31	Continuous recording mode		C A S D

Group (\*)

C: Check

S: Service

A: Adjust

D: Develop

- For details of each adjustment mode, refer to “5. Electrical Adjustments”.  
For details of “ERR DP MODE”, refer to “Self-Diagnosis Function” on page 2.
- If a different mode has been selected by mistake, press the **[MENU/NO]** button to exit that mode.
- Modes with (X) in the Mark column are not used for servicing and therefore are not described in detail. If these modes are set accidentally, press the **[MENU/NO]** button to exit the mode immediately. Be especially careful not to set the modes with (!) as they will overwrite the non-volatile memory and reset it, and as a result, the unit will not operate normally.

### 5-1. Operating the Continuous Playback Mode

#### 1. Entering the continuous playback mode

- (1) Set the disc in the unit. (Whichever recordable discs or discs for playback only are available.)
- (2) Turn the **[◀◀ AMS ▶▶]** knob and display “CPLAY MODE” (C30).
- (3) Press the **[YES]** button to change the display to “CPLAY MID”.
- (4) When access completes, the display changes to “C1 = [ ] AD = [ ]”.

**Note:** The numbers “[ ]” displayed show you error rates and ADER.

#### 2. Changing the parts to be played back

- (1) Press the **[YES]** button during continuous playback to change the display as below.



When pressed another time, the parts to be played back can be moved.

- (2) When access completes, the display changes to “C1 = [ ] AD = [ ]”.

**Note:** The numbers “[ ]” displayed show you error rates and ADER.

#### 3. Ending the continuous playback mode

- (1) Press the **[MENU/NO]** button. The display will change to “CPLAY MODE”.
- (2) Press the **[EJECT]** button to remove the disc.

**Note:** The playback start addresses for IN, MID, and OUT are as follows.

IN	40h cluster
MID	300h cluster
OUT	700h cluster

### 5-2. Operating the Continuous Recording Mode (Use only when performing self-recording/palyback check.)

#### 1. Entering the continuous recording mode

- (1) Set a recordable disc in the unit.
- (2) Turn the **[◀◀ AMS ▶▶]** knob and display “CREC MODE”.
- (3) Press the **[YES]** button to change the display to “CREC MID” (C31).
- (4) When access completes, the display changes to “CREC [ ]” and **REC** lights up.

**Note:** The numbers “[ ]” displayed shows you the recording position addresses.

#### 2. Changing the parts to be recorded

- (1) When the **[YES]** button is pressed during continuous recording, the display changes as below.



When pressed another time, the parts to be recorded can be changed. **REC** goes off.

- (2) When access completes, the display changes to “CREC [ ]” and **REC** lights up.

**Note:** The numbers “[ ]” displayed shows you the recording position addresses.

#### 3. Ending the continuous recording mode

- (1) Press the **[MENU/NO]** button. The display changes to “CREC MODE” and **REC** goes off.
- (2) Press the **[EJECT]** button to remove the disc.

**Note 1:** The recording start addresses for IN, MID, and OUT are as follows.

IN	40h cluster
MID	300h cluster
OUT	700h cluster

**Note 2:** The **[MENU/NO]** button can be used to stop recording anytime.

**Note 3:** Do not perform continuous recording for long periods of time above 5 minutes.

**Note 4:** During continuous recording, be careful not to apply vibration.

### 5-3. Non-Volatile Memory Mode (EEP MODE)

This mode reads and writes the contents of the non-volatile memory.

It is not used in servicing. If set accidentally, press the **[MENU/NO]** button immediately to exit it.

## 6. FUNCTIONS OF OTHER BUTTONS

Function	Contents
▷	Sets continuous playback when pressed in the STOP state. When pressed during continuous playback, the tracking servo turns ON/OFF.
■	Stops continuous playback and continuous recording.
▶▶	The sled moves to the outer circumference only when this is pressed.
◀◀	The sled moves to the inner circumference only when this is pressed.
SCROLL	Switches between the pit and groove modes when pressed.
PLAY MODE	Switches the spindle servo mode (CLVS ↔ CLV A).
LEVEL/DISPLAY/CHAR	Switches the displayed contents each time the button is pressed
EJECT ≡	Ejects the disc
REPEAT	Exits the test mode

## 7. TEST MODE DISPLAYS

Each time the [DISPLAY/CHAR] button is pressed, the display changes in the following order.

### 1. Mode display

Displays “TEMP ADJUST”, “CPLAYMODE”, etc.

### 2. Error rate display

Displays the error rate in the following way.

C1 = □□□□ AD = □□

C1 = Indicates the C1 error.

AD = Indicates ADER.

### 3. Address display

The address is displayed as follows. (MO: recordable disc, CD: playback only disc)

Pressing the [SCROLL/CLOCK SET] button switches between the group display and bit display.

h = □□□□ s = □□□□ (MO pit and CD)

h = □□□□ a = □□□□ (MO groove)

h = Indicates the header address.

s = Indicates the SUBQ address.

a = Indicates the ADIP address.

**Note:** “-” is displayed when servo is not imposed.

### 4. Auto gain display (Not used in servicing)

The auto gain is displayed as follows.

AG = □□/□□[□□]

### 5. Detrack check display (Not used in servicing)

The detrack is displayed as follows.

ADR = □□□□□□

### 6. IVR display (Not used in servicing)

The IVR is displayed as follows.

[□□][□□][□□]

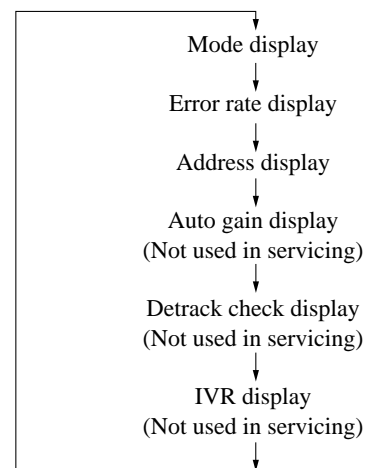

## MEANINGS OF OTHER DISPLAYS

Display	Contents	
	When Lit	When Off
▶	During continuous playback (CLV: ON)	STOP (CLV: OFF)
	Tracking servo OFF	Tracking servo ON
REC	Recording mode ON	Recording mode OFF
SYNC	CLV low speed mode	CLV normal mode
L.SYNC	ABCD adjustment completed	
OVER	Tracking offset cancel ON	Tracking offset cancel OFF
B	Tracking auto gain OK	
A-	Focus auto gain OK	
TRACK	Pit	Groove
DISC	High reflection	Low reflection
SLEEP	CLV-S	CLV-A
MONO	CLV LOCK	CLV UNLOCK

## SECTION 5 ELECTRICAL ADJUSTMENTS

### 1. PARTS REPLACEMENT AND ADJUSTMENT

- Check and adjust the MDM and MBU as follows.  
The procedure changes according to the part replaced

- Abbreviation  
OP : Optical pick-up  
OWH : Overwrite head

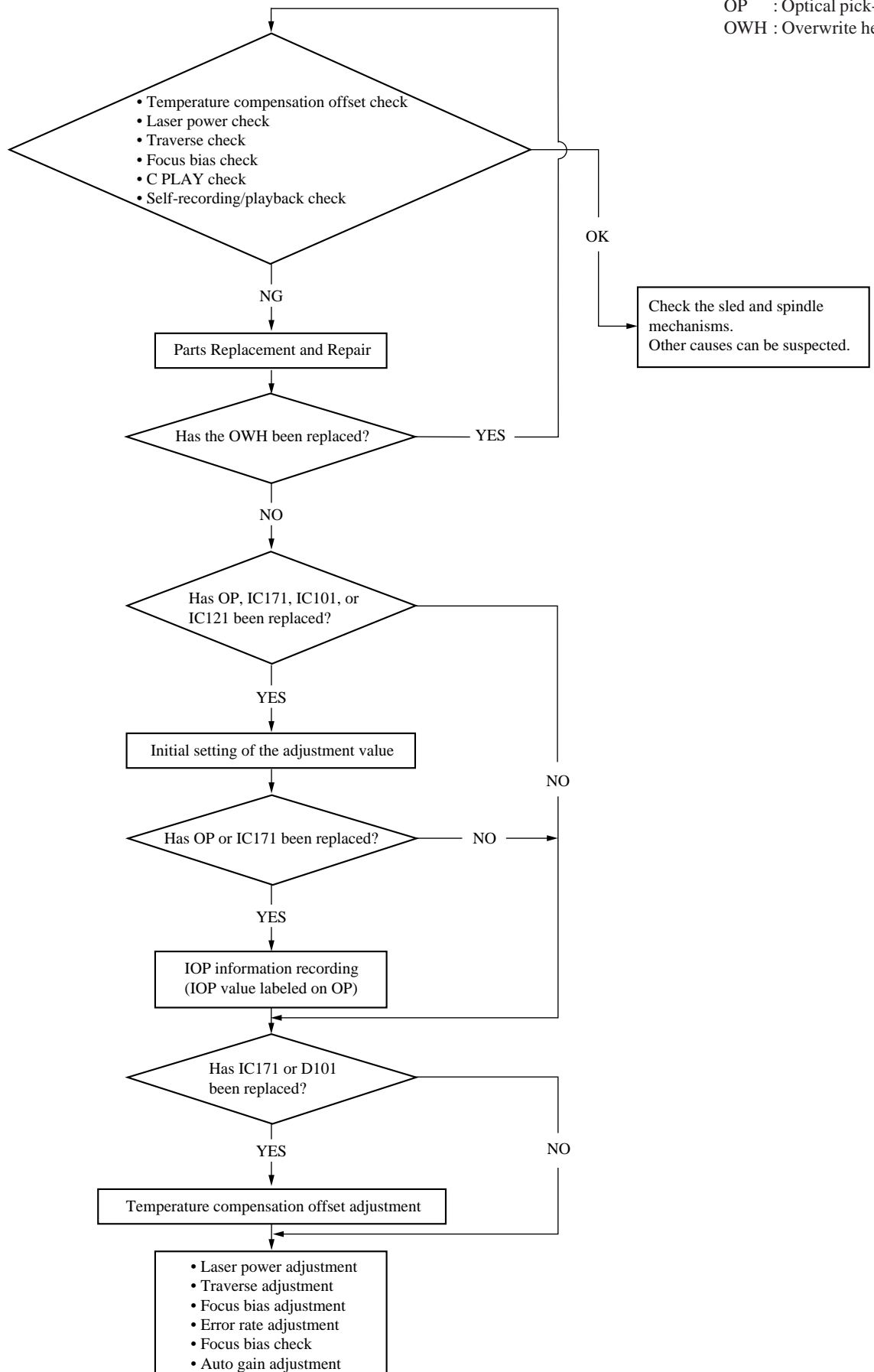

## 2. PRECAUTIONS FOR CHECKING LASER DIODE EMISSION

To check the emission of the laser diode during adjustments, never view directly from the top as this may lose your eye-sight.

## 3. PRECAUTIONS FOR USE OF OPTICAL PICK-UP (KMS-260A)

As the laser diode in the optical pick-up is easily damaged by static electricity, solder the laser tap of the flexible board when using it. Before disconnecting the connector, desolder first. Before connecting the connector, be careful not to remove the solder. Also take adequate measures to prevent damage by static electricity. Handle the flexible board with care as it breaks easily.

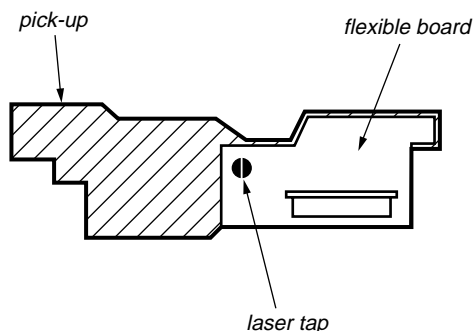

**Optical pick-up flexible board**

## 4. PRECAUTIONS FOR ADJUSTMENTS

1. When replacing the following parts, perform the adjustments and checks with **O** in the order shown in the following table.

	Optical Pick-up	BD Board			
		IC171	D101	IC101, IC121	IC192
1. Initial setting of adjustment value	O	O	X	O	X
2. Recording of IOP information (Value written in the pick-up)	O	O	X	X	X
3. Temperature compensation offset adjustment	X	O	O	X	X
4. Laser power adjustment	O	O	X	O	O
5. Traverse adjustment	O	O	X	O	X
6. Focus bias adjustment	O	O	X	O	X
7. Error rate check	O	O	X	O	X
8. Auto gain output level adjustment	O	O	X	O	X

- Set the test mode when performing adjustments. After completing the adjustments, exit the test mode. Perform the adjustments and checks in "group S" of the test mode.
- Perform the adjustments to be needed in the order shown.

- Use the following tools and measuring devices.
  - Check Disc (MD) TDYS-1 (Parts No. 4-963-646-01)
  - TEST DISK (MDW-74/AU-1) (Parts No. 8-892-341-41)
  - Laser power meter LPM-8001 (Parts No. J-2501-046-A) or MD Laser power meter 8010S (Parts No. J-2501-145-A)
  - Oscilloscope (Measure after performing CAL of prove)
  - Digital voltmeter
  - Thermometer
  - Jig for checking BD board waveform (Parts No. : J-2501-149-A)
- When observing several signals on the oscilloscope, etc., make sure that VC and ground do not connect inside the oscilloscope. (VC and ground will become short-circuited)
- Using the above jig enables the waveform to be checked without the need to solder. (Refer to Servicing Notes on page 6)
- As the disc used will affect the adjustment results, make sure that no dusts nor fingerprints are attached to it.

## Laser power meter

When performing laser power checks and adjustment (electrical adjustment), use of the new MD laser power meter 8010S (J-2501-145-A) instead of the conventional laser power meter is convenient.

It sharply reduces the time and trouble to set the laser power meter sensor onto the objective lens of the pick-up.

## 5. CREATING CONTINUOUSLY-RECORDED DISC

\* This disc is used in focus bias adjustment and error rate check. The following describes how to create a continuous recording disc.

- Insert a disc (blank disc) commercially available.
- Turn the **◀◀ AMS ▶▶** knob and display "CREC MODE". (C31)
- Press the **YES** button again to display "CREC MID". Display "CREC (0300)" and start to recording.
- Complete recording within 5 minutes.
- Press the **MENU/NO** button and stop recording.
- Press the **EJECT** button and remove the disc.

The above has been how to create a continuous recorded data for the focus bias adjustment and error rate check.

### Note :

- Be careful not to apply vibration during continuous-recording.

## 6. CHECK PRIOR TO REPAIRS

These checks are performed before replacing parts according to “approximate specifications” to determine the faulty locations. For details, refer to “Checks Prior to Parts Replacement and Adjustments” (See page 8).

### 6-1. Temperature Compensation Offset Check

When performing adjustments, set the internal temperature and room temperature of 22 °C to 28 °C.

#### Checking Procedure:

1. Turn the **AMS** knob to display “TEMP CHECK” (C01).
2. Press the **YES** button.
3. “T=@@ (##) [OK]” should be displayed. If “T=@@ (##) [NG]” is displayed, it means that the results are bad.  
(@@ indicates the current value set, and ## indicates the value written in the non-volatile memory)

### 6-2. Laser Power Check

Before checking, check the IOP value of the optical pick-up.  
(Refer to 5-8. Recording and Displaying IOP Information)

#### Connection :

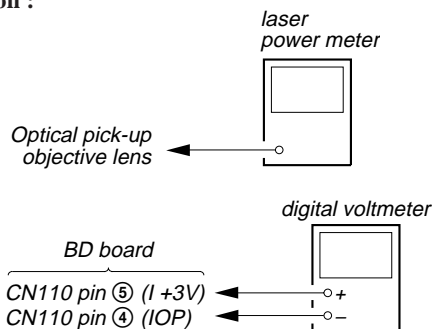

#### Checking Procedure:

1. Set the laser power meter on the objective lens of the optical pick-up. (When it cannot be set properly, press the **AMS** button or **AMS** button to move the optical pick-up)  
Connect the digital voltmeter to CN110 pin ⑤ (I+3V) and CN110 pin ④ (IOP).
2. Then, turn the **AMS** knob and display “LDPWR CHECK” (C02).
3. Press the **YES** button once and display “LD 0.9 mW \$ ”. Check that the reading of the laser power meter become 0.84 to 0.92 mW.
4. Press the **YES** button once more and display “LD 7.0 mW \$ ”. Check that the reading the laser power meter and digital voltmeter satisfy the specified value.

#### Specification:

Laser power meter reading:  $7.0 \pm 0.2$  mW

Digital voltmeter reading : Optical pick-up displayed value  $\pm 10\%$

(Optical pick-up label)

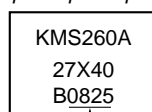

IOP=82.5 mA in this case  
 $IOP (mA) = \text{Digital voltmeter reading (mV)} / 1 (\Omega)$

5. Press the **MENU/NO** button and display “LDPWR CHECK” and stop the laser emission.  
(The **MENU/NO** button is effective at all times to stop the laser emission)

**Note 1:** After step 4, each time the **YES** button is pressed, the display will be switched between “LD 0.7 mW \$ ”, “LD 6.2 mW \$ ”, and “LD Wp ホセイ \$ ”. Nothing needs to be performed here.

### 6-3. Traverse Check

**Note 1:** Data will be erased during MO reading if a recorded disc is used in this adjustment.

**Note 2:** If the traverse waveform is not clear, connect the oscilloscope as shown in the following figure so that it can be seen more clearly.

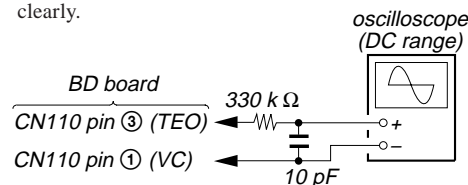

#### Connection :

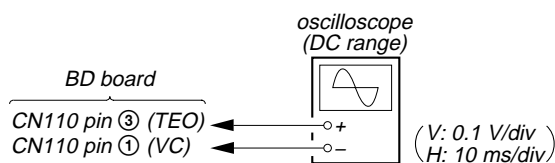

#### Checking Procedure:

1. Connect an oscilloscope to CN110 pin ③ (TEO) and CN110 pin ① (VC) of the BD board.
2. Load a disc (any available on the market). (Refer to Note 1)
3. Press the **AMS** button and move the optical pick-up outside the pit.
4. Turn the **AMS** knob and display “EF MO CHECK” (C03).
5. Press the **YES** button and display “EFB = MO-R”.  
(Laser power READ power/Focus servo ON/tracking servo OFF/spindle (S) servo ON)
6. Observe the waveform of the oscilloscope, and check that the specified value is satisfied. Do not turn the **AMS** knob.  
(Read power traverse checking)

(Traverse Waveform)

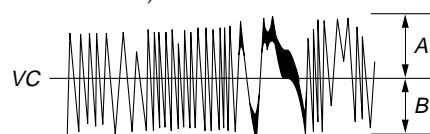

Specified value : Below 10% offset value

$$\text{Offset value (\%)} = \frac{|A - B|}{2(A + B)} \times 100$$

7. Press the **YES** button and display “EFB = MO-W”.
8. Observe the waveform of the oscilloscope, and check that the specified value is satisfied. Do not turn the **AMS** knob.  
(Write power traverse checking)

(Traverse Waveform)

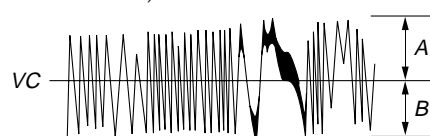

Specified value : Below 10% offset value

$$\text{Offset value (\%)} = \frac{|A - B|}{2(A + B)} \times 100$$

9. Press the **[YES]** button display “EFB = **000** MO-P”. Then, the optical pick-up moves to the pit area automatically and servo is imposed.
10. Observe the waveform of the oscilloscope, and check that the specified value is satisfied. Do not turn the **[◀◀ AMS ▶▶]** knob.

(Traverse Waveform)

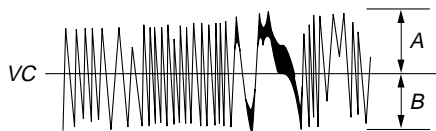

Specified value : Below 10% offset value

$$\text{Offset value (\%)} = \frac{|A - B|}{2(A + B)} \times 100$$

11. Press the **[YES]** button display “EF MO CHECK”. The disc stops rotating automatically.
12. Press the **[EJECT]** button and remove the disc.
13. Load the check disc (MD) TDYS-1.
14. Turn the **[◀◀ AMS ▶▶]** knob and display “EF CD CHECK” (C04).
15. Press the **[YES]** button and display “EFB = **000** CD”. Servo is imposed automatically.
16. Observe the waveform of the oscilloscope, and check that the specified value is satisfied. Do not turn the **[◀◀ AMS ▶▶]** knob.

(Traverse Waveform)

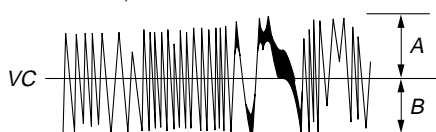

Specified value : Below 10% offset value

$$\text{Offset value (\%)} = \frac{|A - B|}{2(A + B)} \times 100$$

17. Press the **[YES]** button and display “EF CD CHECK”.
18. Press the **[EJECT]** button and take out the check disc.

#### 6-4. Focus Bias Check

Change the focus bias and check the focus tolerance amount.

Checking Procedure :

1. Load the test disk (MDW-74/AU-1).
2. Turn the **[◀◀ AMS ▶▶]** knob and display “CPLAY MODE” (C30).
3. Press the **[YES]** button twice and display “CPLAY MID”.
4. Press the **[MENU/NO]** button when “C = **0000** AD = **00**” is displayed.
5. Turn the **[◀◀ AMS ▶▶]** knob and display “FBIAS CHECK” (C05).
6. Press the **[YES]** button and display “**0000/00** c = **00**”. The first four digits indicate the C1 error rate, the two digits after [ / ] indicate ADER, and the 2 digits after [ c = ] indicate the focus bias value. Check that the C1 error is below 50 and ADER is below 2.
7. Press the **[YES]** button and display “**0000/00** b = **00**”. Check that the C1 error is about 200 and ADER is below 2.
8. Press the **[YES]** button and display “**0000/00** a = **00**”. Check that the C1 error is about 200 and ADER is below 2.
9. Press the **[MENU/NO]** button, next press the **[EJECT]** button and take out the test disc.

#### 6-5. C PLAY Checking

##### MO Error Rate Check

Checking Procedure :

1. Load the test disk (MDW-74/AU-1).
2. Turn the **[◀◀ AMS ▶▶]** knob and display “CPLAY MODE” (C30).
3. Press the **[YES]** button and display “CPLAY MID”.
4. The display changes to “C = **0000** AD = **00**”.
5. If the C1 error rate is below 80, check that ADER is below 2.
6. Press the **[MENU/NO]** button, stop playback, press the **[EJECT]** button and take out the test disc.

##### CD Error Rate Check

Checking Procedure :

1. Load the check disc (MD) TDYS-1.
2. Turn the **[◀◀ AMS ▶▶]** knob and display “CPLAY MODE” (C30).
3. Press the **[YES]** button twice and display “CPLAY MID”.
4. The display changes to “C = **0000** AD = **00**”.
5. Check that the C1 error rate is below 50.
6. Press the **[MENU/NO]** button, stop playback, press the **[EJECT]** button and take out the check disc.

#### 6-6. Self-Recording/playback Check

Prepare a continuous recording disc using the unit to be repaired and check the error rate.

Checking Procedure :

1. Insert a recordable disc (blank disc) into the unit.
2. Turn the **[◀◀ AMS ▶▶]** knob to display “CREC MODE” (C31).
3. Press the **[YES]** button to display the “CREC MID”.
4. When recording starts, “**REC**” is displayed, this becomes “CREC @@@@” (@@@@ is the address), and recording starts.
5. About 1 minute later, press the **[MENU/NO]** button to stop continuous recording.
6. Turn the **[◀◀ AMS ▶▶]** knob to display “CPLAY MODE” (C30).
7. Press the **[YES]** button to display “CPLAY MID”.
8. “C = **0000** AD = **00**” will be displayed.
9. Check that the C1 error becomes below 80 and the AD error below 2.
10. Press the **[MENU/NO]** button to stop playback, and press the **[EJECT]** button and take out the disc.



## 7. INITIAL SETTING OF ADJUSTMENT VALUE

### Note:

Mode which sets the adjustment results recorded in the non-volatile memory to the initial setting value. However the results of the temperature compensation offset adjustment will not change to the initial setting value.

If initial setting is performed, perform all adjustments again excluding the temperature compensation offset adjustment.

For details of the initial setting, refer to "4. Precautions on Adjustments" and execute the initial setting before the adjustment as required.

### Setting Procedure :

1. Turn the **[◀◀ AMS ▶▶]** knob to display "ADJ CLEAR (C24)".
2. Press the **[YES]** button. "Complete!" will be displayed momentarily and initial setting will be executed, after which "ADJ CLEAR" will be displayed.

## 8. RECORDING AND DISPLAYING THE IOP INFORMATION

The IOP data can be recorded in the non-volatile memory. The IOP value on the label of the optical pickup and the IOP value after the adjustment will be recorded. Recording these data eliminates the need to read the label on the optical pick-up.

### Recording Procedure :

1. Turn the **[◀◀ AMS ▶▶]** knob to display "Iop Write" (C28), and press the **[YES]** button.
2. The display becomes Ref=@@.@ (@ is an arbitrary number) and the numbers which can be changed will blink.
3. Input the IOP value written on the optical pick-up.  
To select the number : Turn the **[◀◀ AMS ▶▶]** knob.  
To select the digit : Press the **[◀◀ AMS ▶▶]** knob
4. When the **[YES]** button is pressed, the display becomes "Measu=@@.@." (@ is an arbitrary number).
5. As the adjustment results are recorded for the 6 value. Leave it as it is and press the **[YES]** button.
6. "Complete!" will be displayed momentarily. The value will be recorded in the non-volatile memory and the display will become "Iop Write".

### Display Procedure :

1. Turn the **[◀◀ AMS ▶▶]** knob to display "Iop Read"(C27).
2. "@@.@/##.#" is displayed and the recorded contents are displayed.  
@@.@ indicates the IOP value labeled on the pick-up.  
##.# indicates the IOP value after adjustment
3. To end, press the **[◀◀ AMS ▶▶]** button or **[MENU/NO]** button to display "Iop Read".

## 9. TEMPERATURE COMPENSATION OFFSET ADJUSTMENT

Save the temperature data at that time in the non-volatile memory as 25 °C reference data.

### Note :

1. Usually, do not perform this adjustment.
2. Perform this adjustment in an ambient temperature of 22 °C to 28 °C. Perform it immediately after the power is turned on when the internal temperature of the unit is the same as the ambient temperature of 22 °C to 28 °C.
3. When D101 has been replaced, perform this adjustment after the temperature of this part has become the ambient temperature.

### Adjusting Procedure :

1. Turn the **[◀◀ AMS ▶▶]** knob and display "TEMP ADJUST" (C09).
2. Press the **[YES]** button and select the "TEMP ADJUST" mode.
3. "TEMP = [ ] [OK]" and the current temperature data will be displayed.
4. To save the data, press the **[YES]** button.  
When not saving the data, press the **[MENU/NO]** button.
5. When the **[YES]** button is pressed, "TEMP = [ ] SAVE" will be displayed and turned back to "TEMP ADJUST" display then. When the **[MENU/NO]** button is pressed, "TEMP ADJUST" will be displayed immediately.

### Specified Value :

The "TEMP = [ ]" should be within "E0 - EF", "F0 - FF", "00 - 0F", "10 - 1F" and "20 - 2F".

## 10. LASER POWER ADJUSTMENT

Check the IOP value of the optical pick-up before adjustments. (Refer to 8. Recording and Displaying IOP Information)

### Connection :

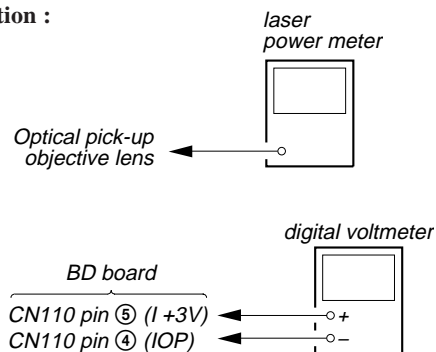

### Adjusting Procedure :

1. Set the laser power meter on the objective lens of the optical pick-up. (When it cannot be set properly, press the **[◀]** button or **[▶]** button to move the optical pick-up.)  
Connect the digital voltmeter to CN110 pin 5 (I+3V) and CN110 pin 4 (IOP).
2. Turn the **[◀◀ AMS ▶▶]** knob and display "LDPWR ADJUST" (C10).  
(Laser power : For adjustment)
3. Press the **[YES]** button once and display "LD 0.9 mW \$ [ ]".
4. Turn the **[◀◀ AMS ▶▶]** knob so that the reading of the laser power meter becomes 0.85 to 0.91 mW. Press the **[YES]** button after setting the range knob of the laser power meter, and save the adjustment results. ("LD SAVE \$ [ ]" will be displayed for a moment.)
5. Then "LD 7.0 mW \$ [ ]" will be displayed.
6. Turn the **[◀◀ AMS ▶▶]** knob so that the reading of the laser power meter becomes 6.9 to 7.1 mW, press the **[YES]** button and save it.

**Note:** Do not perform the emission with 7.0 mW more than 15 seconds continuously.

7. Then, turn the **[◀ AMS ▶]** knob and display “LDPWR CHECK” (C02).
8. Press the **[YES]** button once and display “LD 0.9 mW \$ [ ]”. Check that the reading of the laser power meter become 0.85 to 0.91 mW.
9. Press the **[YES]** button once more and display “LD 7.0 mW \$ [ ]”. Check that the reading the laser power meter and digital volt meter satisfy the specified value.  
Note down the digital voltmeter reading value.

**Specification:**

Laser power meter reading:  $7.0 \pm 0.2$  mW  
 Digital voltmeter reading : Optical pick-up displayed value  $\pm 10\%$

(Optical pick-up label)

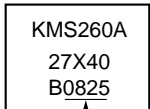

$IOP = 82.5$  mA in this case  
 $IOP$  (mA) = Digital voltmeter reading (mV)/1 ( $\Omega$ )

10. Press the **[MENU/NO]** button and display “LDPWR CHECK” and stop the laser emission.  
(The **[MENU/NO]** button is effective at all times to stop the laser emission.)
11. Turn the **[◀ AMS ▶]** knob to display “Iop Write”(C28).
12. Press the **[YES]** button. When the display becomes Ref=@@.@ (@ is an arbitrary number), press the **[YES]** button to display “Measu=@@.@” (@ is an arbitrary number).
13. The numbers which can be changed will blink. Input the Iop value noted down at step 9.  
To select the number : Turn the **[◀ AMS ▶]** knob.  
To select the digit : Press the **[◀ AMS ▶]** knob.
14. When the **[YES]** button is pressed, “Complete!” will be displayed momentarily. The value will be recorded in the non-volatile memory and the display will become “Iop Write”.

**Note 1:** After step 4, each time the **[YES]** button is pressed, the display will be switched between “LD 0.7 mW \$ [ ]”, “LD 6.2 mW \$ [ ]”, and “LD Wp 本 ㇿ ㇿ \$ [ ]”. Nothing needs to be performed here.

**11. TRAVERSE ADJUSTMENT**

**Note 1:** Data will be erased during MO reading if a recorded disc is used in this adjustment.  
**Note 2:** If the traverse waveform is not clear, connect the oscilloscope as shown in the following figure so that it can be seen more clearly.

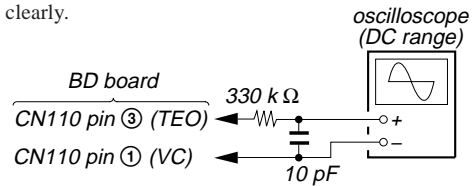

**Connection :**

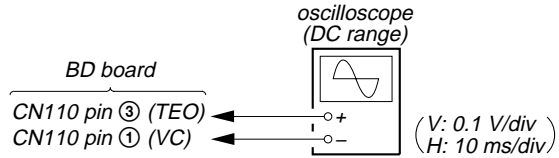

**Adjusting Procedure :**

1. Connect an oscilloscope to CN110 pin ③ (TEO) and CN110 pin ① (VC) of the BD board.
2. Load a disc (any available on the market). (Refer to Note 1)
3. Press the **[▶▶]** button and move the optical pick-up outside the pit.
4. Turn the **[◀ AMS ▶]** knob and display “EF MO ADJUST” (C10).
5. Press the **[YES]** button and display “EFB = [ ] MO-R”. (Laser power READ power/Focus servo ON/tracking servo OFF/spindle (S) servo ON)
6. Turn the **[◀ AMS ▶]** knob so that the waveform of the oscilloscope becomes the specified value.  
(When the **[◀ AMS ▶]** knob is turned, the [ ] of “EFB = [ ]” changes and the waveform changes.) In this adjustment, waveform varies at intervals of approx. 2%. Adjust the waveform so that the specified value is satisfied as much as possible.  
(Read power traverse adjustment)

(Traverse Waveform)



Specification A = B

7. Press the **[YES]** button and save the result of adjustment to the non-volatile memory (“EFB = [ ] SAV” will be displayed for a moment. Then “EFB = [ ] MO-W” will be displayed).

- Turn the **[◀◀ AMS ▶▶]** knob so that the waveform of the oscilloscope becomes the specified value.  
(When the **[◀◀ AMS ▶▶]** knob is turned, the **[ ]** of “EFB-**[ ]**” changes and the waveform changes.) In this adjustment, waveform varies at intervals of approx. 2%. Adjust the waveform so that the specified value is satisfied as much as possible.  
(Write power traverse adjustment)

(Traverse Waveform)

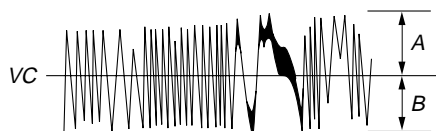

Specification A = B

- Press the **[YES]** button, and save the adjustment results in the non-volatile memory. (“EFB = **[ ]** SAV” will be displayed for a moment.)
- “EFB = **[ ]** MO-P”. will be displayed.  
The optical pick-up moves to the pit area automatically and servo is imposed.
- Turn the **[◀◀ AMS ▶▶]** knob until the waveform of the oscilloscope moves closer to the specified value.  
In this adjustment, waveform varies at intervals of approx. 2%. Adjust the waveform so that the specified value is satisfied as much as possible.

(Traverse Waveform)

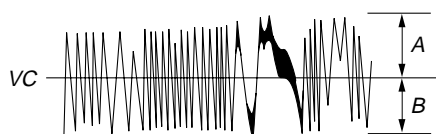

Specification A = B

- Press the **[YES]** button, and save the adjustment results in the non-volatile memory. (“EFB = **[ ]** SAV” will be displayed for a moment.)  
Next “EF MO ADJUST” is displayed. The disc stops rotating automatically.
- Press the **[EJECT]** button and take out the disc.
- Load the check disc (MD) TDYS-1.
- Turn the **[◀◀ AMS ▶▶]** knob and display “EF CD ADJUST” (C12).
- Press the **[YES]** button and display “EFB = **[ ]** CD”. Servo is imposed automatically.
- Turn the **[◀◀ AMS ▶▶]** knob so that the waveform of the oscilloscope moves closer to the specified value.  
In this adjustment, waveform varies at intervals of approx. 2%. Adjust the waveform so that the specified value is satisfied as much as possible.

(Traverse Waveform)

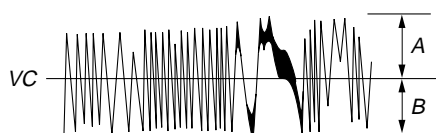

Specification A = B

- Press the **[YES]** button, display “EFB = **[ ]** SAV” for a moment and save the adjustment results in the non-volatile memory.  
Next “EF CD ADJUST” will be displayed.
- Press the **[EJECT]** button and take out the disc.

## 12. FOCUS BIAS ADJUSTMENT

### Adjusting Procedure :

- Load the continuously-recorded disc. (Refer to “5. CREATING CONTINUOUSLY-RECORDED DISC”)
- Turn the **[◀◀ AMS ▶▶]** knob and display “CPLAY MODE” (C29).
- Press the **[YES]** button and display “CPLAY MID”.
- Press the **[MENU/NO]** button when “C1 = **[ ]** AD = **[ ]**” is displayed.
- Turn the **[◀◀ AMS ▶▶]** knob and display “FBIAS ADJUST” (C13).
- Press the **[YES]** button and display “**[ ]** a = **[ ]**”.  
The first four digits indicate the C1 error rate, the two digits after **[/]** indicate ADER, and the 2 digits after **[a =]** indicate the focus bias value.
- Turn the **[◀◀ AMS ▶▶]** knob in the clockwise direction and find the focus bias value at which the C1 error rate becomes about 200 (Refer to Note 2).
- Press the **[YES]** button and display “**[ ]** b = **[ ]**”.
- Turn the **[◀◀ AMS ▶▶]** knob in the counterclockwise direction and find the focus bias value at which the C1 error rate becomes about 200.
- Press the **[YES]** button and display “**[ ]** c = **[ ]**”.
- Check that the C1 error rate is below 50 and ADER is 00. Then press the **[YES]** button.
- If the “**[ ]**” in “**[ ]** - **[ ]** - **[ ]** (**[ ]**)” is above 20, press the **[YES]** button.  
If below 20, press the **[MENU/NO]** button and repeat the adjustment from step 2.
- Press the **[EJECT]** button and take out the disc.

**Note 1:** The relation between the C1 error and focus bias is as shown in the following figure. Find points A and B in the following figure using the above adjustment. The focal point position C is automatically calculated from points A and B.

**Note 2:** As the C1 error rate changes, perform the adjustment using the average value.

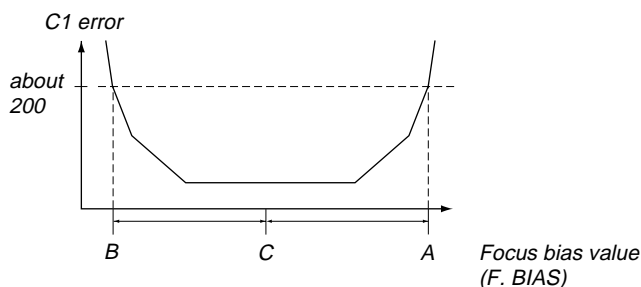

## 13. ERROR RATE CHECK

### 13-1. CD Error Rate Check

#### Checking Procedure :

1. Load the check disc (MD) TDYS-1.
2. Turn the [◀◀ AMS ▶▶] knob and display “CPLAY MODE” (C30).
3. Press the [YES] button twice and display “CPLAY MID”.
4. The display changes to “C1 = [ ] AD = [ ]”.
5. Check that the C1 error rate is below 20.
6. Press the [MENU/NO] button, stop playback, press the [EJECT] button and take out the check disc.

### 13-2. MO Error Rate Check

#### Checking Procedure :

1. Load the test disc (MDW-74/AU-1).
2. Turn the [◀◀ AMS ▶▶] knob and display “CPLAY MODE” (C30).
3. Press the [YES] button and display “CPLAY MID”.
4. The display changes to “C1 = [ ] AD = [ ]”.
5. If the C1 error rate is below 50, check that ADER is 00.
6. Press the [MENU/NO] button, stop playback, press the [EJECT] button and take out the test disc.

## 14. FOCUS BIAS CHECK

Change the focus bias and check the focus tolerance amount.

#### Checking Procedure :

1. Load the continuously-recorded disc. (Refer to “5. CREATING CONTINUOUSLY-RECORDED DISC”)
2. Turn the [◀◀ AMS ▶▶] knob and display “CPLAY MODE” (C30).
3. Press the [YES] button twice and display “CPLAY MID”.
4. Press the [MENU/NO] button when “C1 = [ ] AD = [ ]” is displayed.
5. Turn the [◀◀ AMS ▶▶] knob and display “FBIAS CHECK” (C05).
6. Press the [YES] button and display “[ ]/[ ] c = [ ]”.  
The first four digits indicate the C1 error rate, the two digits after [ / ] indicate ADER, and the 2 digits after [ c = ] indicate the focus bias value.  
Check that the C1 error is below 50 and ADER is below 2.
7. Press the [YES] button and display “[ ]/[ ] b = [ ]”.  
Check that the C1 error is about 200 and ADER is below 2.
8. Press the [YES] button and display “[ ]/[ ] a = [ ]”.  
Check that the C1 error is about 200 and ADER is below 2.
9. Press the [MENU/NO] button, next press the [EJECT] button and take out the disc.

**Note 1:** If the C1 error and ADER are above other than the specified value at points a (step 8. in the above) or b (step 7. in the above), the focus bias adjustment may not have been carried out properly. Adjust perform the beginning again.

## 15. AUTO GAIN CONTROL OUTPUT LEVEL ADJUSTMENT

Be sure to perform this adjustment when the pickup is replaced. If the adjustment results becomes “Adjust NG!”, the pickup may be faulty or the servo system circuits may be abnormal.

### 15-1. CD Auto Gain Control Output Level Adjustment

#### Adjusting Procedure :

1. Insert the check disc (MD) TDYS-1.
2. Turn the [◀◀ AMS ▶▶] knob to display “AG Set (CD)” (C26).
3. When the [YES] button is pressed, the adjustment will be performed automatically.  
“Complete!!” will then be displayed momentarily when the value is recorded in the non-volatile memory, after which the display changes to “AG Set (CD)”.
4. Press the [EJECT] button and take out the check disc.

### 15-2. MO Auto Gain Control Output Level Adjustment

#### Adjusting Procedure :

1. Insert the test disc (MDW-74/AU-1) for recording.
2. Turn the [◀◀ AMS ▶▶] knob to display “AG Set (MO)” (C25).
3. When the [YES] button is pressed, the adjustment will be performed automatically.  
“Complete!!” will then be displayed momentarily when the value is recorded in the non-volatile memory, after which the display changes to “AG Set (MO)”.
4. Press the [EJECT] button and take out the test disc.

**Adjustment Location:**

– **BD BOARD** (Side A) –

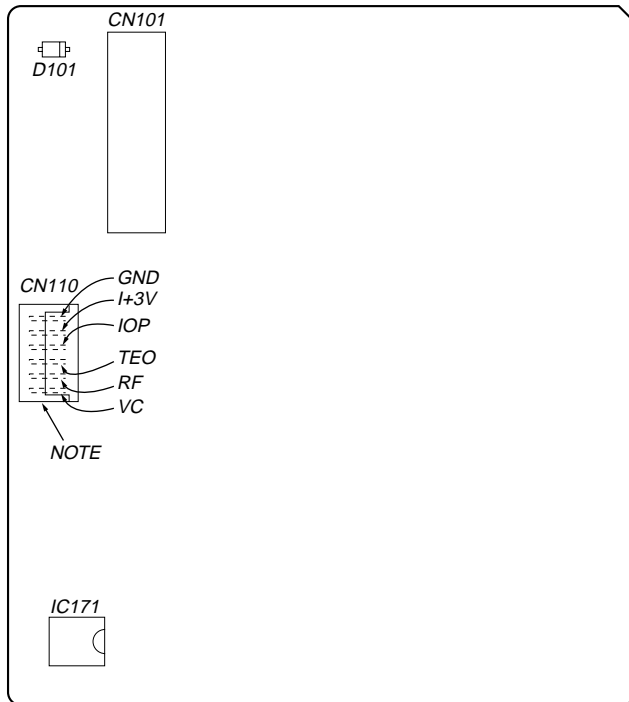

– **BD BOARD** (Side B) –

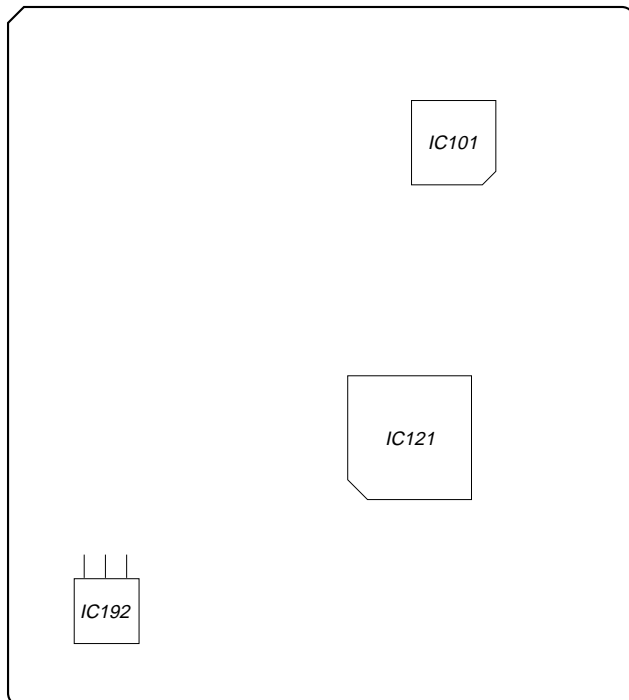

**Note:** It is useful to use the jig. for checking the waveform. (Refer to Servicing Notes on page 6)

## SECTION 6 DIAGRAMS

### 6-1. IC PIN FUNCTION DESCRIPTION

#### • BD BOARD IC101 CXA2523AR (RF AMP, FOCUS/TRACKING ERROR AMP)

Pin No.	Pin Name	I/O	Description
1	I	I	I-V converted RF signal I input from the optical pick-up block detector
2	J	I	I-V converted RF signal J input from the optical pick-up block detector
3	VC	O	Middle point voltage (+1.65V) generation output terminal
4 to 9	A to F	I	Signal input from the optical pick-up detector
10	PD	I	Light amount monitor input from the optical pick-up block laser diode
11	APC	O	Laser amplifier output terminal to the automatic power control circuit
12	APCREF	I	Reference voltage input terminal for setting laser power
13	GND	—	Ground terminal
14	TEMPI	I	Connected to the temperature sensor
15	TEMPR	O	Output terminal for a temperature sensor reference voltage
16	SWDT	I	Writing serial data input from the CXD2654R (IC121)
17	SCLK	I	Serial data transfer clock signal input from the CXD2654R (IC121)
18	XLAT	I	Serial data latch pulse signal input from the CXD2654R (IC121)
19	$\overline{\text{XSTBY}}$	I	Standby signal input terminal “L”: standby (fixed at “H” in this set)
20	F0CNT	I	Center frequency control voltage input terminal of internal circuit (BPF22, BPF3T, EQ) input from the CXD2654R (IC121)
21	VREF	O	Reference voltage output terminal Not used (open)
22	EQADJ	I	Center frequency setting terminal for the internal circuit (EQ)
23	3TADJ	I	Center frequency setting terminal for the internal circuit (BPF3T)
24	VCC	—	Power supply terminal (+3.3V)
25	WBLADJ	I	Center frequency setting terminal for the internal circuit (BPF22)
26	TE	O	Tracking error signal output to the CXD2654R (IC121)
27	CSLED	I	Connected to the external capacitor for low-pass filter of the sled error signal
28	SE	O	Sled error signal output to the CXD2654R (IC121)
29	ADFM	O	FM signal output of the ADIP
30	ADIN	I	Receives a ADIP FM signal in AC coupling
31	ADAGC	I	Connected to the external capacitor for ADIP AGC
32	ADFG	O	ADIP duplex signal (22.05 kHz $\pm$ 1 kHz) output to the CXD2654R (IC121)
33	AUX	O	Auxiliary signal (I <sub>3</sub> signal/temperature signal) output to the CXD2654R (IC121)
34	FE	O	Focus error signal output to the CXD2654R (IC121)
35	ABCD	O	Light amount signal (ABCD) output to the CXD2654R (IC121)
36	BOTM	O	Light amount signal (RF/ABCD) bottom hold output to the CXD2654R (IC121)
37	PEAK	O	Light amount signal (RF/ABCD) peak hold output to the CXD2654R (IC121)
38	RF	O	Playback EFM RF signal output to the CXD2654R (IC121)
39	RFAGC	I	Connected to the external capacitor for RF auto gain control circuit
40	AGCI	I	Receives a RF signal in AC coupling
41	COMPO	O	User comparator output terminal Not used (open)
42	COMPP	I	User comparator input terminal Not used (fixed at “L”)
43	ADDC	I	Connected to the external capacitor for cutting the low band of the ADIP amplifier
44	OPO	O	User operational amplifier output terminal Not used (open)
45	OPN	I	User operational amplifier inversion input terminal Not used (fixed at “L”)
46	RFO	O	RF signal output terminal
47	MORFI	I	Receives a MO RF signal in AC coupling
48	MORFO	O	MO RF signal output terminal

• **BD BOARD IC121 CXD2654R**

**(DIGITAL SIGNAL PROCESSOR, DIGITAL SERVO PROCESSOR, EFM/ACIRC ENCODER/DECODER, SHOCK PROOF MEMORY CONTROLLER, ATRAC ENCODER/DECODER)**

Pin No.	Pin Name	I/O	Description
1	MNT0 (FOK)	O	Focus OK signal output to the system controller (IC501) “H” is output when focus is on (“L”: NG)
2	MNT1 (SHOCK)	O	Track jump detection signal output to the system controller (IC501)
3	MNT2 (XBUSY)	O	Busy monitor signal output to the system controller (IC501)
4	MNT3 (SLOCK)	O	Spindle servo lock status monitor signal output to the system controller (IC501)
5	SWDT	I	Writing serial data signal input from the system controller (IC501)
6	SCLK	I (S)	Serial data transfer clock signal input from the system controller (IC501)
7	XLAT	I (S)	Serial data latch pulse signal input from the system controller (IC501)
8	SRDT	O (3)	Reading serial data signal output to the system controller (IC501)
9	SENS	O (3)	Internal status (SENSE) output to the system controller (IC501)
10	$\overline{\text{XRST}}$	I (S)	Reset signal input from the system controller (IC501) “L”: reset
11	SQSY	O	Subcode Q sync (SCOR) output to the system controller (IC501) “L” is output every 13.3 msec Almost all, “H” is output
12	DQSY	O	Digital In U-bit CD format subcode Q sync (SCOR) output to the system controller (IC501) “L” is output every 13.3 msec Almost all, “H” is output
13	RECP	I	Laser power selection signal input from the system controller (IC501) “L”: playback mode, “H”: recording mode
14	XINT	O	Interrupt status output to the system controller (IC501)
15	TX	I	Recording data output enable signal input from the system controller (IC501) Writing data transmission timing input (Also serves as the magnetic head on/off output)
16	OSCI	I	System clock signal (512Fs=22.5792 MHz) input terminal
17	OSCO	O	System clock signal (512Fs=22.5792 MHz) output terminal Not used (open)
18	XTSL	I	Input terminal for the system clock frequency setting “L”: 45.1584 MHz, “H”: 22.5792 MHz (fixed at “H” in this set)
19	DIN0	I	Digital audio signal input terminal when recording mode (for digital optical input) Not used
20	DIN1	I	Digital audio signal input terminal when recording mode (for digital optical input)
21	DOUT	O	Digital audio signal output terminal when playback mode (for digital optical output) Not used
22	DATAI	I	Serial data input terminal Not used (fixed at “L”)
23	LRCKI	I	L/R sampling clock signal (44.1 kHz) input terminal Not used (fixed at “L”)
24	XBCKI	I	Bit clock signal (2.8224 MHz) input terminal Not used (fixed at “L”)
25	ADDT	I	Recording data input from the A/D, D/A converter (IC301)
26	DADT	O	Playback data output to the A/D, D/A converter (IC301)
27	LRCK	O	L/R sampling clock signal (44.1 kHz) output to the A/D, D/A converter (IC301)
28	XBCK	O	Bit clock signal (2.8224 MHz) output to the A/D, D/A converter (IC301)
29	FS256	O	Clock signal (11.2896 MHz) output terminal Not used (open)
30	DVDD	—	Power supply terminal (+3.3V) (digital system)
31 to 34	A03 to A00	O	Address signal output to the D-RAM (IC124)
35	A10	O	Address signal output to the external D-RAM Not used (open)
36 to 40	A04 to A08	O	Address signal output to the D-RAM (IC124)
41	A11	O	Address signal output to the external D-RAM Not used (open)
42	DVSS	—	Ground terminal (digital system)
43	$\overline{\text{XOE}}$	O	Output enable signal output to the D-RAM (IC124) “L” active
44	$\overline{\text{XCAS}}$	O	Column address strobe signal output to the D-RAM (IC124) “L” active

\* I (S) stands for schmitt input, I (A) for analog input, O (3) for 3-state output, and O (A) for analog output in the column I/O.

Pin No.	Pin Name	I/O	Description
45	A09	O	Address signal output to the D-RAM (IC124)
46	$\overline{\text{XRAS}}$	O	Row address strobe signal output to the D-RAM (IC124) "L" active
47	$\overline{\text{XWE}}$	O	Write enable signal output to the D-RAM (IC124) "L" active
48	D1	I/O	Two-way data bus with the D-RAM (IC124)
49	D0	I/O	
50	D2	I/O	
51	D3	I/O	
52	MVCI	I (S)	Digital in PLL oscillation input from the external VCO Not used (fixed at "L")
53	ASYO	O	Playback EFM full-swing output terminal
54	ASYI	I (A)	Playback EFM asymmetry comparator voltage input terminal
55	AVDD	—	Power supply terminal (+3.3V) (analog system)
56	BIAS	I (A)	Playback EFM asymmetry circuit constant current input terminal
57	RFI	I (A)	Playback EFM RF signal input from the CXA2523AR (IC101)
58	AVSS	—	Ground terminal (analog system)
59	PCO	O (3)	Phase comparison output for master clock of the recording/playback EFM master PLL
60	FILI	I (A)	Filter input for master clock of the recording/playback master PLL
61	FILO	O (A)	Filter output for master clock of the recording/playback master PLL
62	CLTV	I (A)	Internal VCO control voltage input of the recording/playback master PLL
63	PEAK	I (A)	Light amount signal (RF/ABCD) peak hold input from the CXA2523AR (IC101)
64	BOTM	I (A)	Light amount signal (RF/ABCD) bottom hold input from the CXA2523AR (IC101)
65	ABCD	I (A)	Light amount signal (ABCD) input from the CXA2523AR (IC101)
66	FE	I (A)	Focus error signal input from the CXA2523AR (IC101)
67	AUX1	I (A)	Auxiliary signal (I <sub>3</sub> signal/temperature signal) input from the CXA2523AR (IC101)
68	VC	I (A)	Middle point voltage (+1.65V) input from the CXA2523AR (IC101)
69	ADIO	O (A)	Monitor output of the A/D converter input signal Not used (open)
70	AVDD	—	Power supply terminal (+3.3V) (analog system)
71	ADRT	I (A)	A/D converter operational range upper limit voltage input terminal (fixed at "H" in this set)
72	ADRB	I (A)	A/D converter operational range lower limit voltage input terminal (fixed at "L" in this set)
73	AVSS	—	Ground terminal (analog system)
74	SE	I (A)	Sled error signal input from the CXA2523AR (IC101)
75	TE	I (A)	Tracking error signal input from the CXA2523AR (IC101)
76	DCHG	I (A)	Connected to the +3.3V power supply
77	APC	I (A)	Error signal input for the laser automatic power control Not used (fixed at "H")
78	ADFG	I (S)	ADIP duplex FM signal (22.05 kHz $\pm$ 1 kHz) input from the CXA2523AR (IC101)
79	F0CNT	O	Filter f <sub>0</sub> control signal output to the CXA2523AR (IC101)
80	XLRF	O	Serial data latch pulse signal output to the CXA2523AR (IC101)
81	CKRF	O	Serial data transfer clock signal output to the CXA2523AR (IC101)
82	DTRF	O	Writing serial data output to the CXA2523AR (IC101)
83	APCREF	O	Control signal output to the reference voltage generator circuit for the laser automatic power control
84	LDDR	O	PWM signal output for the laser automatic power control Not used (open)
85	TRDR	O	Tracking servo drive PWM signal (–) output to the BH6511FS (IC152)
86	TFDR	O	Tracking servo drive PWM signal (+) output to the BH6511FS (IC152)
87	DVDD	—	Power supply terminal (+3.3V) (digital system)
88	FFDR	O	Focus servo drive PWM signal (+) output to the BH6511FS (IC152)
89	FRDR	O	Focus servo drive PWM signal (–) output to the BH6511FS (IC152)

\* I (S) stands for schmitt input, I (A) for analog input, O (3) for 3-state output, and O (A) for analog output in the column I/O.



Pin No.	Pin Name	I/O	Description
90	FS4	O	Clock signal (176.4 kHz) output terminal (X'tal system) Not used (open)
91	SRDR	O	Sled servo drive PWM signal (-) output to the BH6511FS (IC152)
92	SFDR	O	Sled servo drive PWM signal (+) output to the BH6511FS (IC152)
93	SPRD	O	Spindle servo drive PWM signal (-) output to the BH6511FS (IC152)
94	SPFD	O	Spindle servo drive PWM signal (+) output to the BH6511FS (IC152)
95	FGIN	I (S)	Input terminal for the test (fixed at "L")
96	TEST1	I	
97	TEST2	I	
98	TEST3	I	
99	DVSS	—	Ground terminal (digital system)
100	EFMO	O	EFM signal output terminal when recording mode

\* I (S) stands for schmitt input, I (A) for analog input, O (3) for 3-state output, and O (A) for analog output in the column I/O.

• MAIN BOARD IC501 M30620MC-400FP (SYSTEM CONTROLLER)

Pin No.	Pin Name	I/O	Description
1, 2	NC	O	Not used (open)
3	C1	O	Monitor output terminal for the test C1 error rate is output when test mode
4	ADER	O	Monitor output terminal for the test ADER is output when test mode
5	SQSY	I	Subcode Q sync (SCOR) input from the CXD2654R (IC121) “L” is input every 13.3 msec Almost all, “H” is input
6	RMC	I	Remote control signal input from the remote control receiver (IC781)
7	A1 IN	I	Sircs remote control signal input of the CONTROL A1 Not used
8	BYTE	I	External data bus line byte selection signal input “L”: 16 bit, “H”: 8 bit (fixed at “L”)
9	CNVSS	—	Ground terminal
10	XT-IN	I	Sub system clock input terminal (32.768 kHz) Not used (fixed at “L”)
11	XT-OUT	O	Sub system clock output terminal (32.768 kHz) Not used (open)
12	$\overline{S.RST}$	I	System reset signal input from the reset signal generator (IC406) “L”: reset For several hundreds msec. after the power supply rises, “L” is input, then it changes to “H”
13	XOUT	O	Main system clock output terminal (10 MHz)
14	GND	—	Ground terminal
15	XIN	I	Main system clock input terminal (10 MHz)
16	+3.3V	—	Power supply terminal (+3.3V)
17	NMI	I	Non-maskable interrupt input terminal (fixed at “H” in this set)
18	DQSY	I	Digital In U-bit CD format subcode Q sync (SCOR) input from the CXD2654R (IC121) “L” is input every 13.3 msec Almost all, “H” is input
19	P.DOWN	I	Power down detection signal input terminal “L”: power down, normally: “H”
20	KEYBOARD CLK	I	Not used (open)
21	KEYBOARD DATA	I	Not used (open)
22	BEEP OUT	O	Beep sound drive signal output terminal Not used (open)
23	XINT	I	Interrupt status input from the CXD2654R (IC121)
24 to 27	NC	O	Not used (open)
28	L3-CLOCK	O	Serial data transfer clock signal output to the A/D, D/A converter (IC301)
29	NC	O	Not used (open)
30	L3-DATA	O	Serial data output to the A/D, D/A converter (IC301)
31	SWDT	O	Writing data output to the CXD2654R (IC121)
32	SRDT	I	Reading data input from the CXD2654R (IC121)
33	SCLK	O	Serial clock signal output to the CXD2654R (IC121)
34	FLCS	O	Chip select signal output to the FL/LED driver (IC761)
35	FLDATA	O	Serial data output to the FL/LED driver (IC761)
36	NC	O	Not used (open)
37	FLCLK	O	Serial data transfer clock signal output to the FL/LED driver (IC761)
38 to 40	NC	O	Not used (open)
41	NC	I	Not used (fixed at “L”)
42	JOG1	I	JOG dial pulse input from the rotary encoder (S713 ◀◀ AMS ▶▶) (B phase input)
43	JOG0	I	JOG dial pulse input from the rotary encoder (S713 ◀◀ AMS ▶▶) (A phase input)
44	NC	O	Not used (open)
45	A1 OUT	O	Sircs remote control signal output of the CONTROL A1 Not used
46	NC	I	Not used (fixed at “L”)
47	L3-MODE	O	L3 mode control signal output to the A/D, D/A converter (IC301)
48	$\overline{DA RST}$	O	Reset signal output for the A/D, D/A converter “L”: reset Not used (open)
49	MUTE	O	Audio line muting on/off control signal output terminal “L”: line muting on

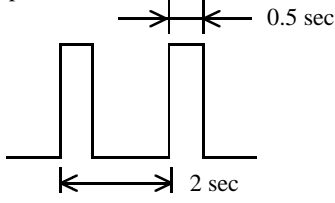
Pin No.	Pin Name	I/O	Description
50	STB	O	Relay drive signal output for the power on/off "L": standby mode, "H": relay on
51	CHACK IN	I	Detection input from the disc chucking-in detect switch "L": chucking Not used (fixed at "H")
52	NC	O	Not used (open)
53	PACK-OUT	I	Detection input from the loading-out detect switch (S602) "L" at a load-out position, others: "H"
54	LDIN	O	Motor control signal output to the loading motor driver (IC441) "L" active *1
55	LDOUT	O	Motor control signal output to the loading motor driver (IC441) "L" active *1
56	LD-LOW	O	Loading motor drive voltage control signal output for the loading motor driver (IC441) "H" active
57, 58	NC	O	Not used (open)
59	REC-P	I	Detection input from the recording position detect switch (S601) "L" active
60	PB-P	I	Detection input from the playback position detect switch (S604) "L" active
61	REC/PB	O	Not used (open)
62	+3.3V	—	Power supply terminal (+3.3V)
63	NC	O	Not used (open)
64	GND	—	Ground terminal
65	SDA	I/O	Two-way data bus with the EEPROM (IC171)
66	MNT3 (SLOCK)	I	Spindle servo lock status monitor signal input from the CXD2654R (IC121)
67	WR-PWR	O	Laser power select signal output to the CXD2654R (IC121) and HF module switch circuit "L": playback mode, "H": recording mode
68	PROTECT	I	Rec-proof claw detect input from the protect detect switch (S102) "H": write protect
69	REFLECT	I	Detection input from the disc reflection rate detect switch (S102) "L": high reflection rate disc, "H": low reflection rate disc
70	LDON	O	Laser diode on/off control signal output to the automatic power control circuit "H": laser on
71	SENS	I	Internal status (SENSE) input from the CXD2654R (IC121)
72	MNT1 (SHOCK)	I	Track jump detection signal input from the CXD2654R (IC121)
73	$\overline{\text{DIG-RST}}$	O	Reset signal output to the CXD2654R (IC121) and BH6511FS (IC152) "L": reset
74	MNT2 (XBUSY)	I	Busy signal input from the CXD2654R (IC121)
75	XLATCH	O	Serial data latch pulse signal output to the CXD2654R (IC121)
76	MOD	O	Laser modulation select signal output to the HF module switch circuit Playback power: "H", Stop: "L", Recording power: 
77	LIMIT-IN	I	Detection input from the sled limit-in detect switch (S101) The optical pick-up is inner position when "L"
78	MNT0 (FOK)	I	Focus OK signal input from the CXD2654R (IC121) "H" is input when focus is on ("L": NG)

\*1 Loading motor (M103) control

Terminal	Mode			
	LOADING	EJECT	BRAKE	RUN IDLE
LDIN (pin ⑤4)	"L"	"H"	"L"	"H"
LDOUT (pin ⑤5)	"H"	"L"	"L"	"H"

Pin No.	Pin Name	I/O	Description
79	SCL	O	Clock signal output to the EEPROM (IC171)
80	SCTX	O	Recording data output enable signal output to the CXD2654R (IC121) and overwrite head driver (IC181) Writing data transmission timing output (Also serves as the magnetic head on/off output)
81	CLOCK SET0	I	Destination setting terminal (US and Canadian models: fixed at "L", AEP, UK and E models: fixed at "H")
82	CLOCK SET1	I	Destination setting terminal (US and Canadian models: fixed at "H", AEP, UK and E models: fixed at "L")
83	LED0	O	LED drive signal output of the ● REC indicator (D741) "L": LED on
84	LED1	O	LED drive signal output of the ▷ indicator (D742) "L": LED on
85	OPT SEL0	O	Not used (open)
86	OPT SEL1	O	Not used (open)
87	MODEL SEL0	I	Setting terminal for the model (fixed at "H" in this set)
88	MODEL SEL1	I	Setting terminal for the model (Not used (open))
89	$\overline{\text{REC}}$	O	Not used (open)
90	BEEP SW	I	BEEP switch input terminal "L": beep off, "H": beep on Not used
91	NC	O	Not used (open)
92	SOURCE	I	INPUT switch (S731) input terminal (A/D input) "L": digital input, "H": analog input
93	KEY3	I	Key input terminal (A/D input) Not used (fixed at "H")
94	KEY2	I	Key input terminal (A/D input) S721 to S726 (EJECT ⏏, PLAY MODE, REPEAT, SCROLL, LEVEL/DISPLAY/CHAR, I/⏏ keys input)
95	KEY1	I	Key input terminal (A/D input) S711 to S714 (MENU/NO, YES, PUSH ENTER, CLEAR keys input)
96	AVSS	—	Ground terminal
97	KEY0	I	Key input terminal (A/D input) S701 to S706 (● REC, ■, ▶▶, ◀◀,   , ▷ keys input)
98	VREF	I	Reference voltage (+3.3V) input terminal (for A/D converter)
99	+3.3V	—	Power supply terminal (+3.3V) (for analog system)
100	MONO/ST	I	Recording mode switch input terminal "L": mono, "H": stereo Not used (open)

6-2. BLOCK DIAGRAM - MD SERVO Section -

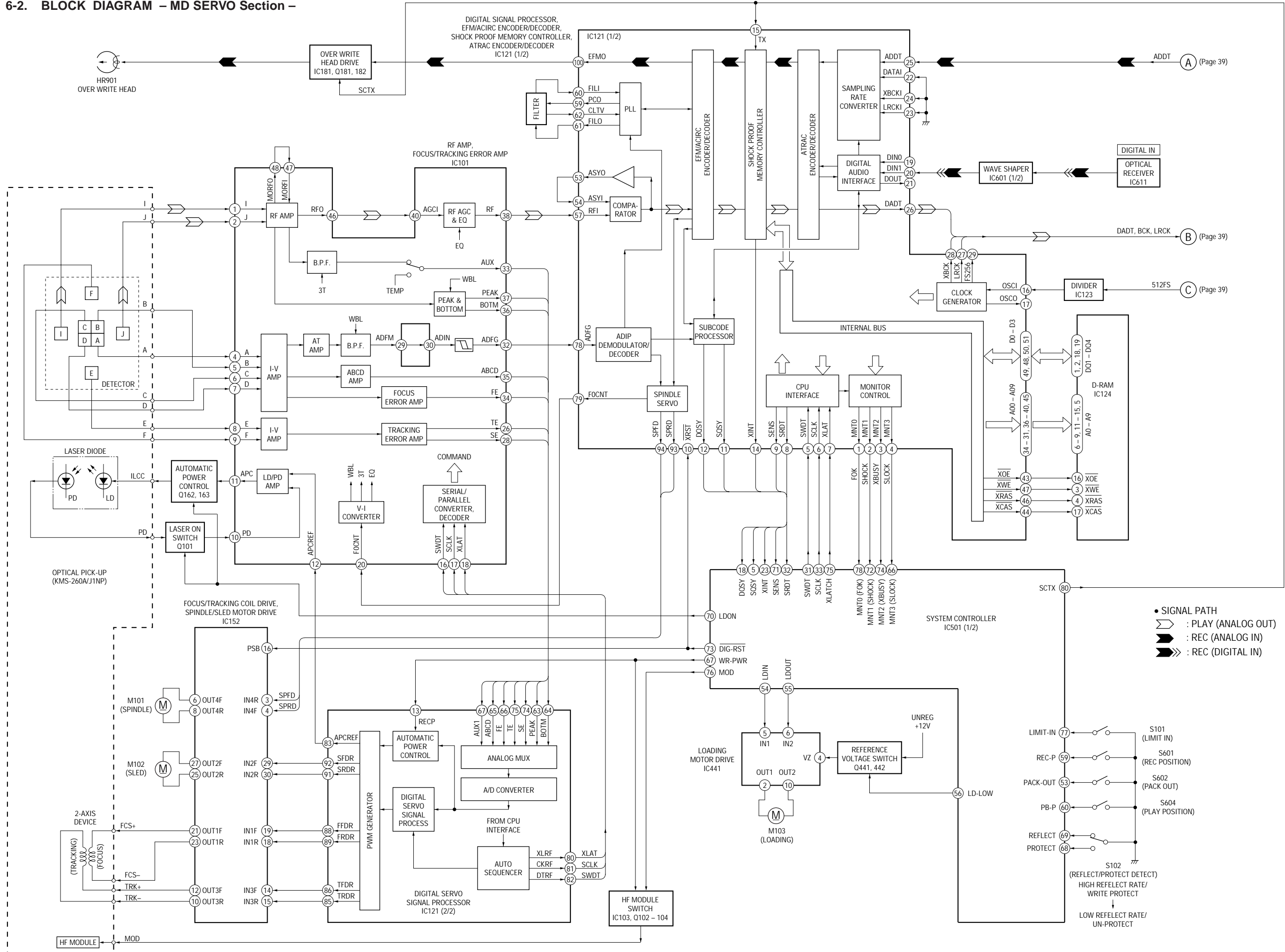

6-3. BLOCK DIAGRAM – MAIN Section –

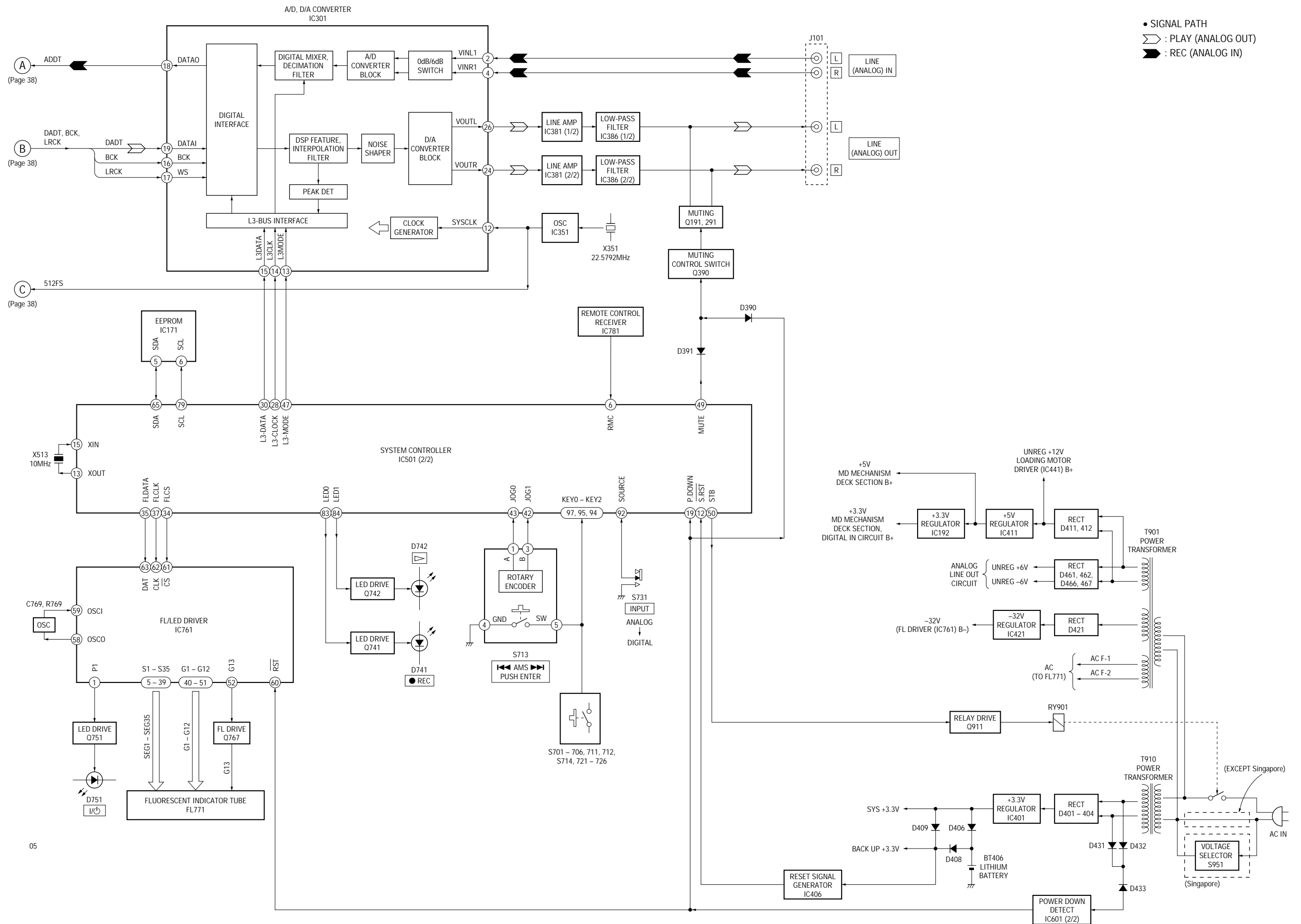

• Circuit Boards Location

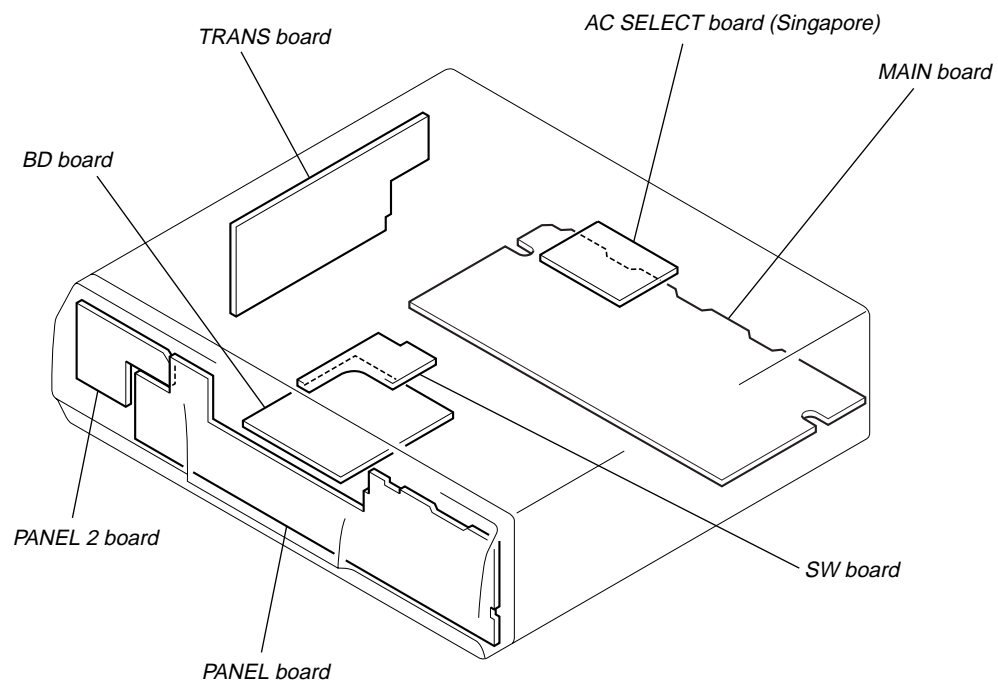

6-4. NOTE FOR PRINTED WIRING BOARDS AND SCHEMATIC DIAGRAMS

Note on Printed Wiring Board:

- : parts extracted from the component side.
- : parts extracted from the conductor side.
- : parts mounted on the conductor side.
- : Through hole.
- : Pattern from the side which enables seeing.

Caution:  
 Pattern face side: Parts on the pattern face side seen from the pattern face are indicated.  
 Parts face side: Parts on the parts face side seen from the parts face are indicated.

- Indication of transistor.

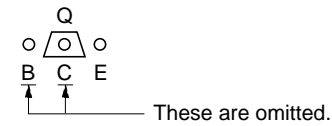

- Abbreviation  
 CND : Canadian model  
 SP : Singapore model

Note on Schematic Diagram:

- All capacitors are in  $\mu\text{F}$  unless otherwise noted. pF:  $\mu\text{F}$  50 WV or less are not indicated except for electrolytics and tantalums.
- All resistors are in  $\Omega$  and  $1/4\text{W}$  or less unless otherwise specified.
- % : indicates tolerance.
- $\Delta$  : internal component.
- : panel designation.

**Note:**  
 The components identified by mark  $\Delta$  or dotted line with mark  $\Delta$  are critical for safety. Replace only with part number specified.

**Note:**  
 Les composants identifiés par une marque  $\Delta$  sont critiques pour la sécurité. Ne les remplacer que par une pièce portant le numéro spécifié.

- : B+ Line.
- : B- Line.
- Voltages and waveforms are dc with respect to ground in playback mode.
- Voltages are taken with a VOM (Input impedance 10 M $\Omega$ ). Voltage variations may be noted due to normal production tolerances.
- Waveforms are taken with a oscilloscope. Voltage variations may be noted due to normal production tolerances.
- Circled numbers refer to waveforms.
- Signal path.  
 : PLAY (ANALOG OUT)  
 : REC (ANALOG IN)  
 : REC (DIGITAL IN)
- Abbreviation  
 CND : Canadian model  
 SP : Singapore model

6-5. PRINTED WIRING BOARD – BD Board – • See page 41 for Circuit Boards Location.

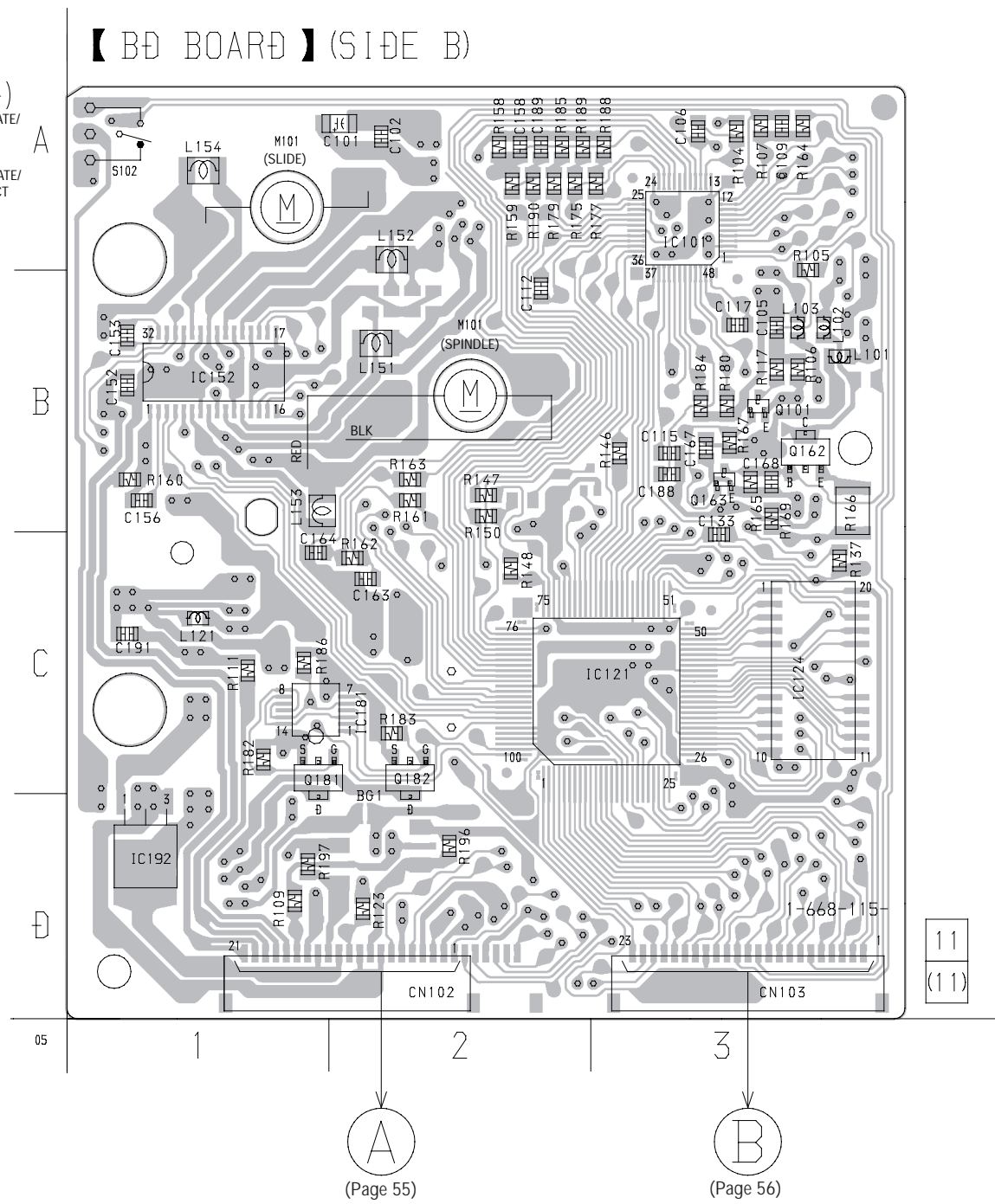
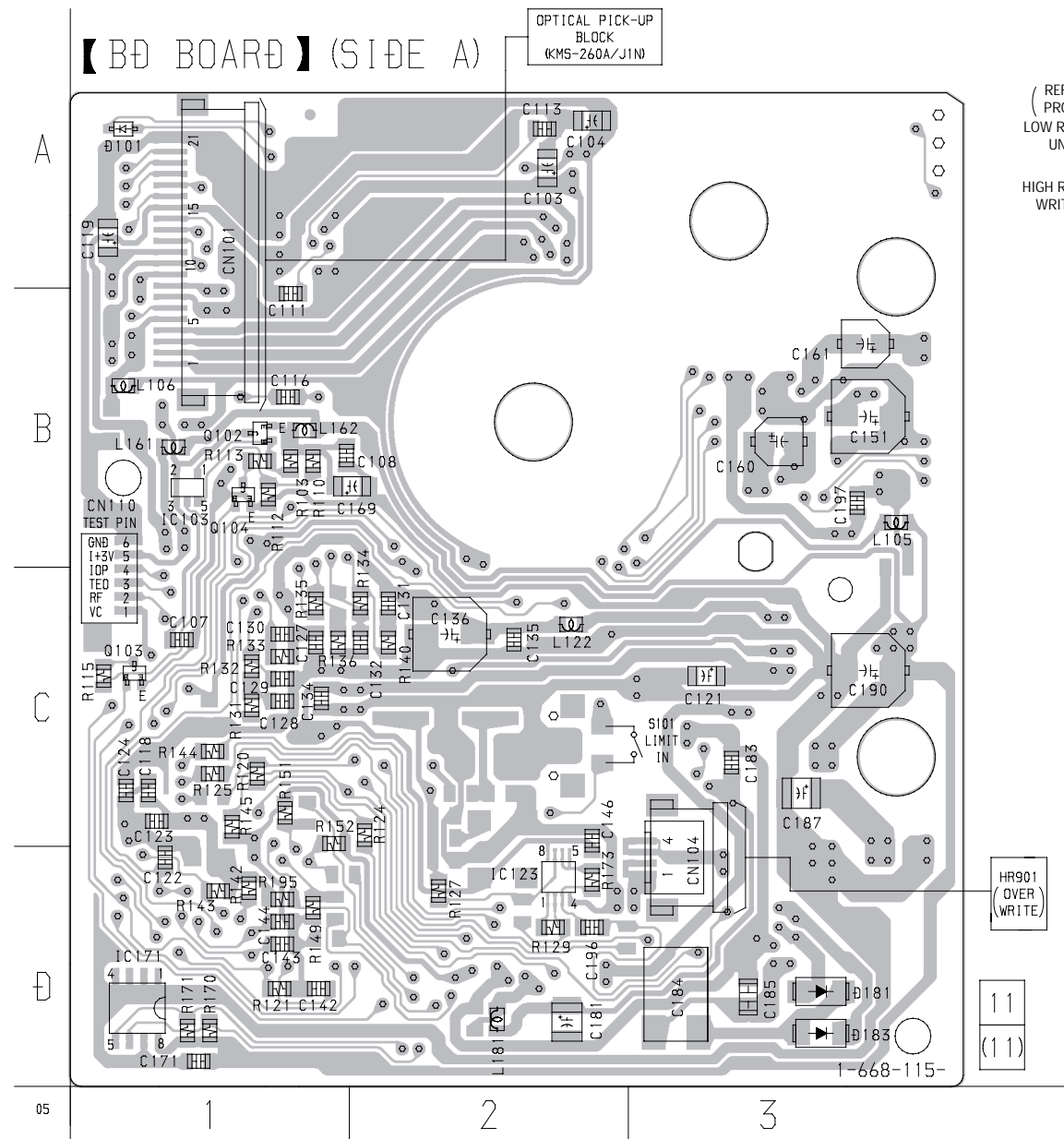

• Semiconductor Location

Ref. No.	Location
D101	A-1
D181	D-3
D183	D-3
IC103	B-1
IC123	D-2
IC171	D-1
Q102	B-1
Q103	C-1
Q104	B-1

• Semiconductor Location

Ref. No.	Location
IC101	A-3
IC121	C-3
IC124	C-3
IC152	B-1
IC181	C-1
IC192	D-1
Q101	B-3
Q162	B-3
Q163	B-3
Q181	C-1
Q182	C-2

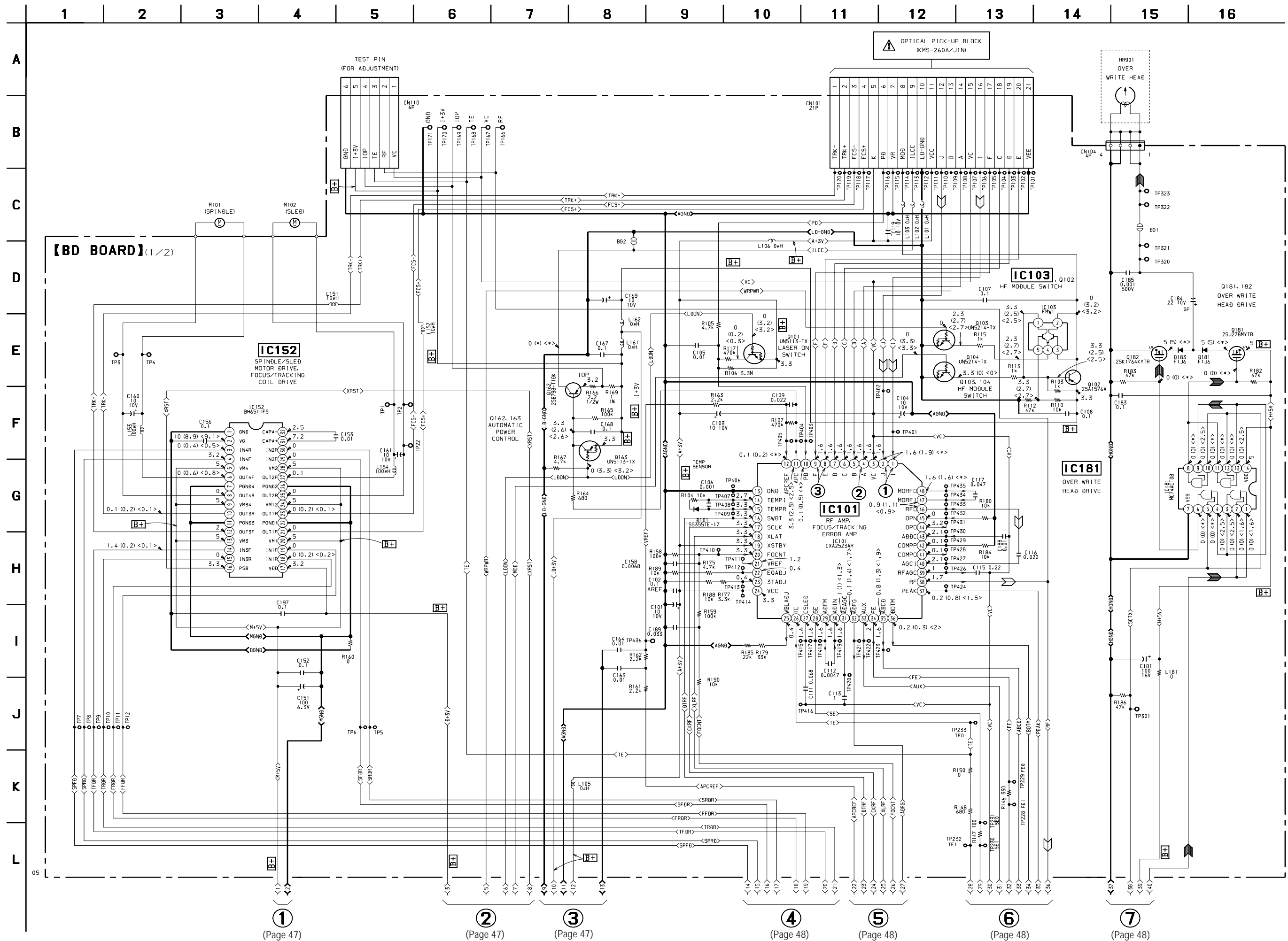

① (Page 47)

② (Page 47)

③ (Page 47)

④ (Page 48)

⑤ (Page 48)

⑥ (Page 48)

⑦ (Page 48)



6-7. SCHEMATIC DIAGRAM – BD Board (2/2) – • See page 65 for Waveforms. • See page 51 for IC Block Diagram.

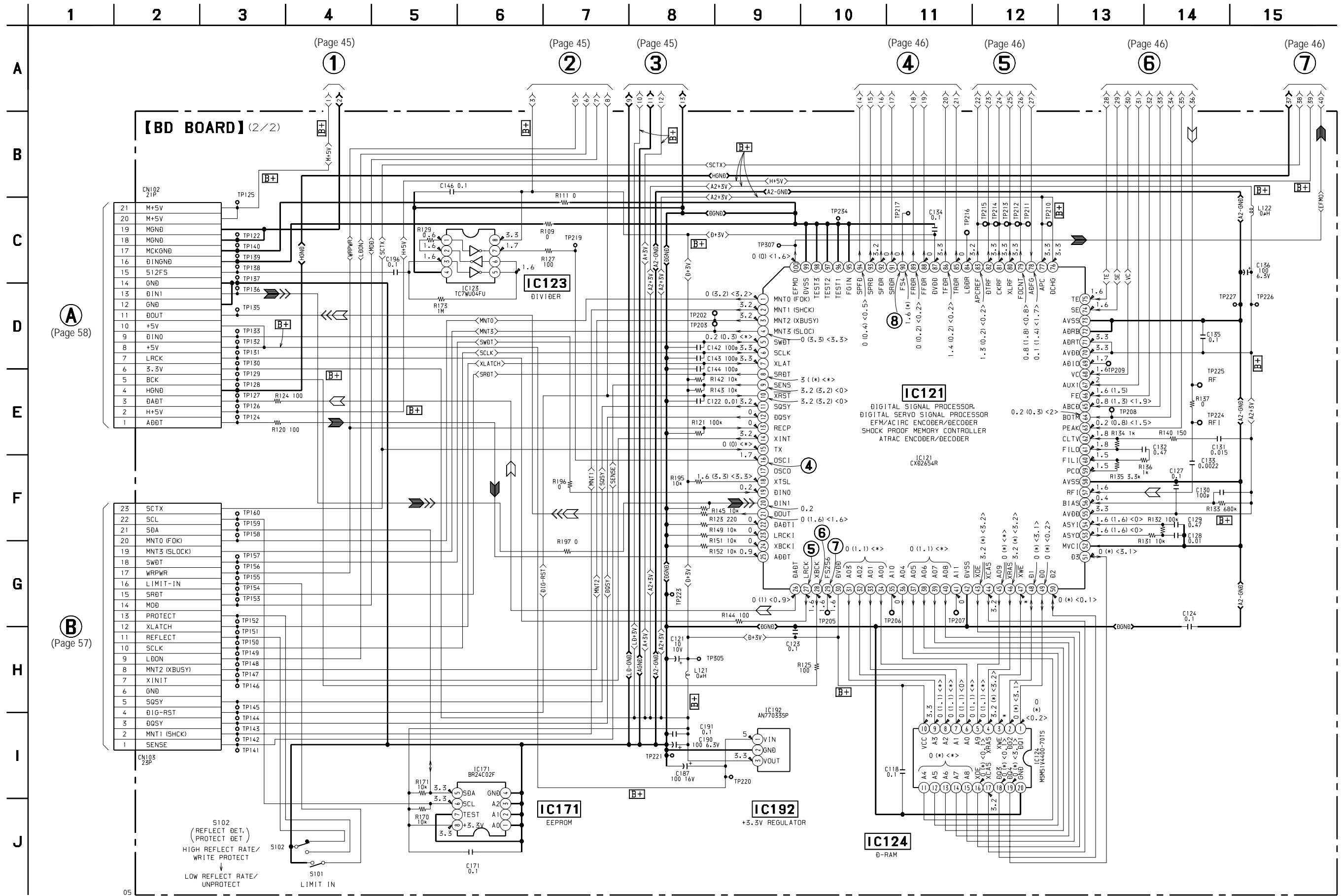

The components identified by mark  $\Delta$  or dotted line with mark  $\Delta$  are critical for safety. Replace only with part number specified.

Les composants identifiés par une marque  $\Delta$  sont critiques pour la sécurité. Ne les remplacer que par une pièce portant le numéro spécifié.

- Voltages and waveforms are dc with respect to ground under no-signal conditions.
- no mark : STOP
- ( ) : PLAY
- < > : REC
- \* : Impossible to measure

6-8. SCHEMATIC DIAGRAM – SW Board –

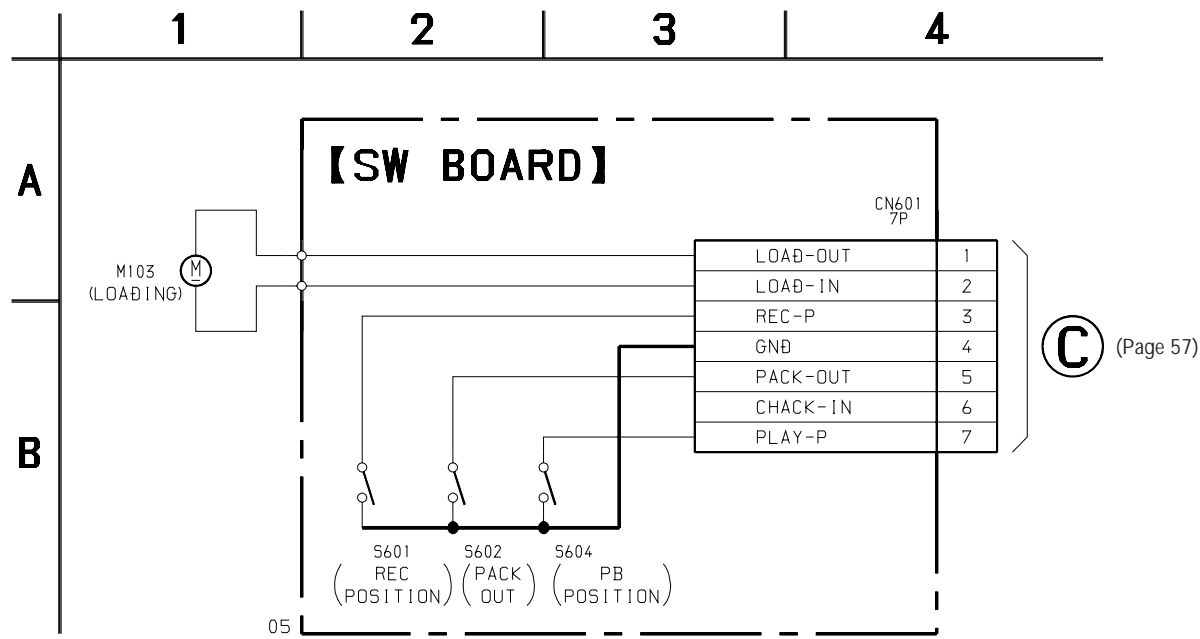

6-9. PRINTED WIRING BOARD – SW Board –

• See page 41 for Circuit Boards Location.

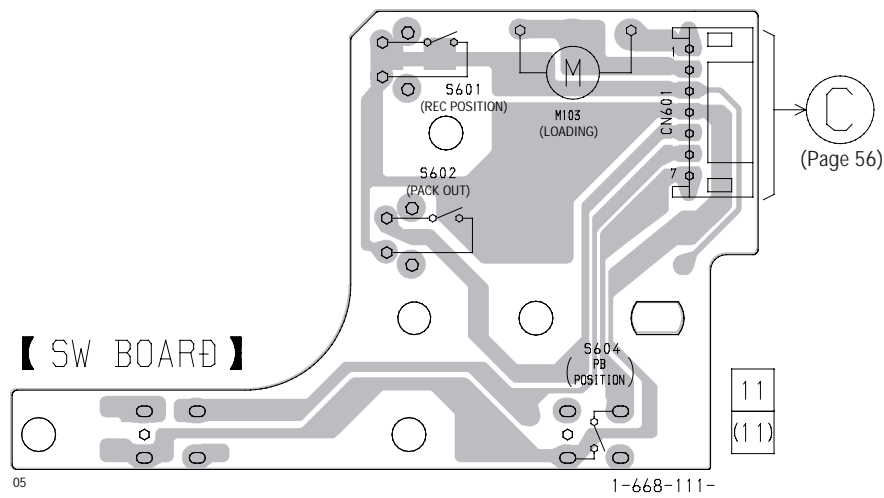

• IC Block Diagrams – BD Board –

IC101 CXA2523AR

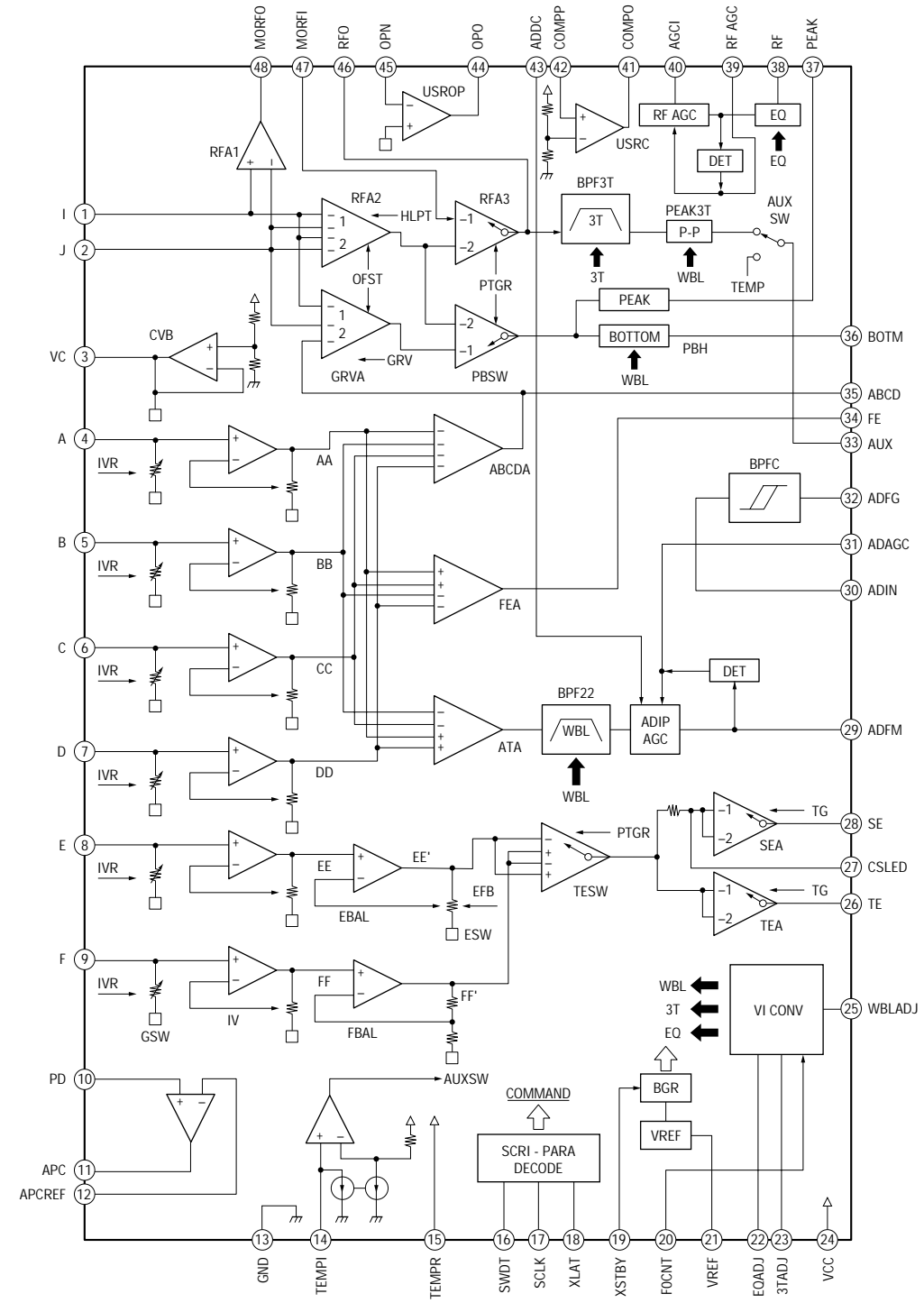

**IC121 CXD2654R**

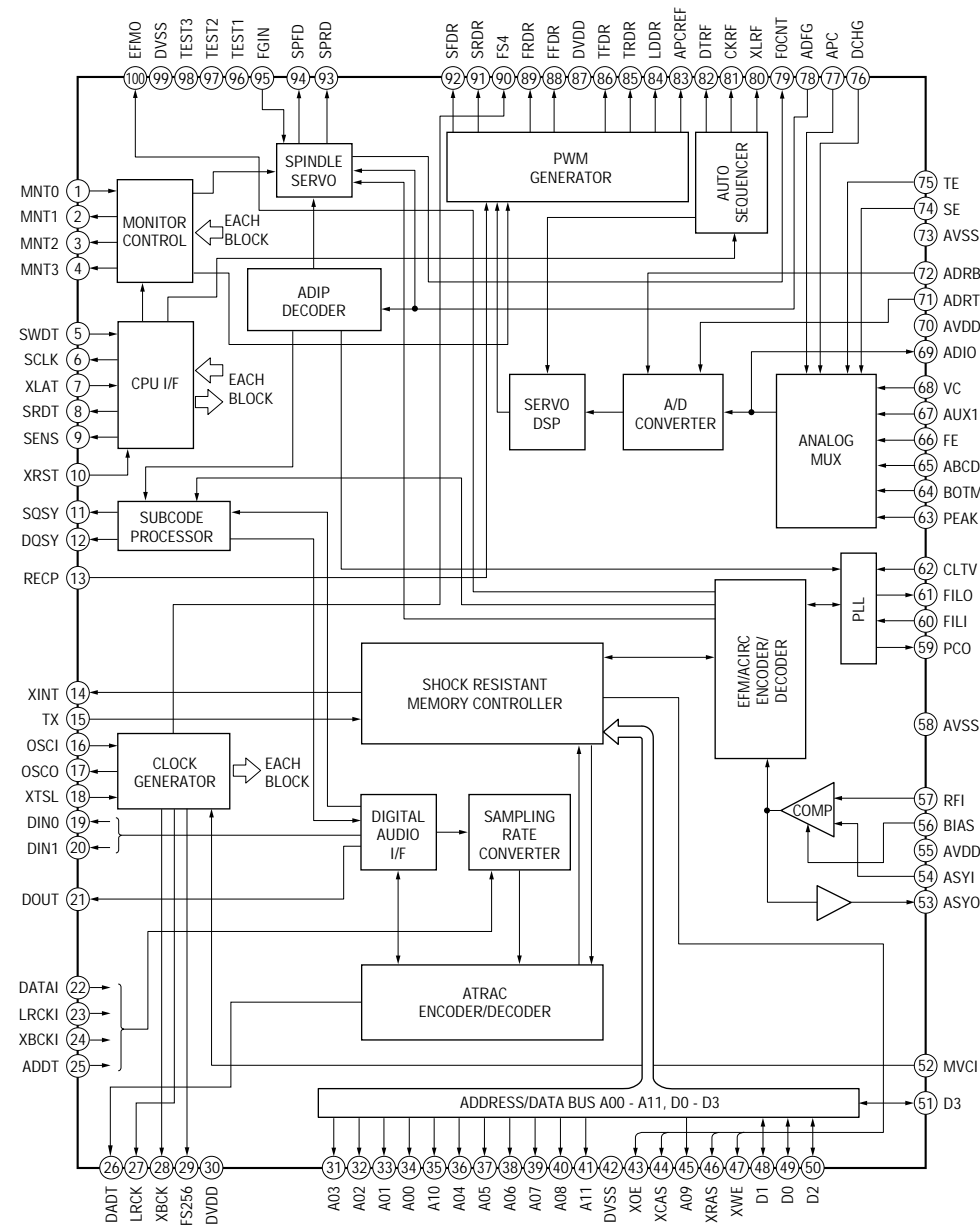

**IC152 BH6511FS-E2**

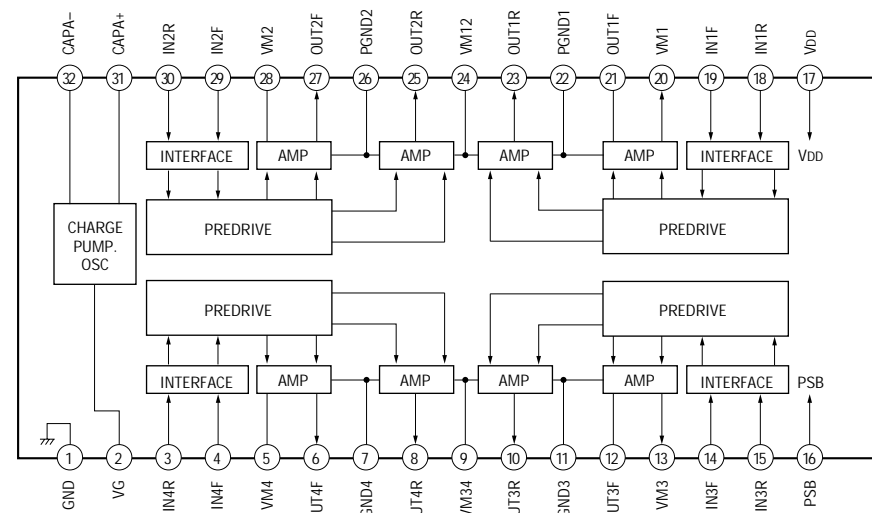

**- MAIN Board -**

**IC301 μDA1341TS/N2**

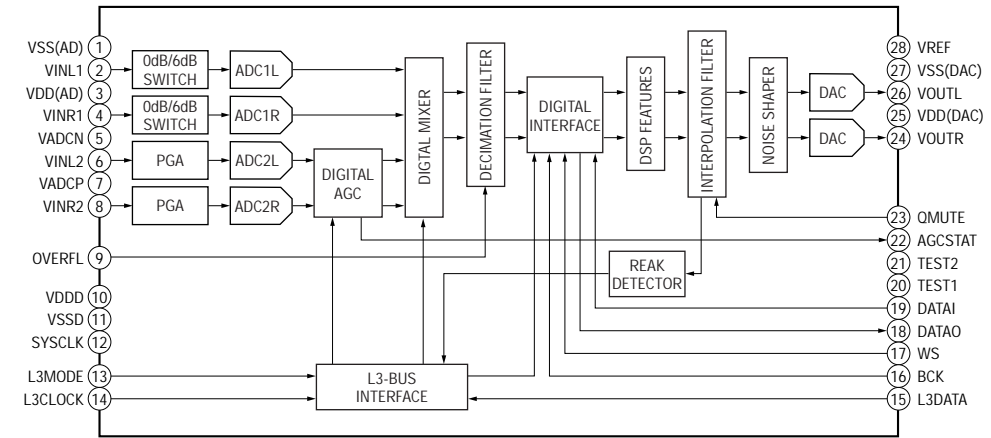

**IC406 M62016L**

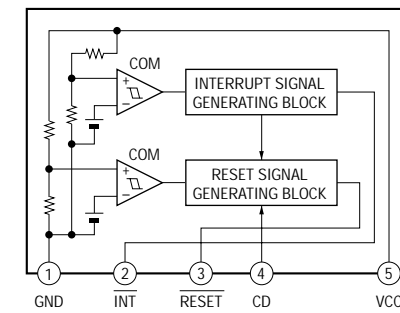

**IC421 M5293L**

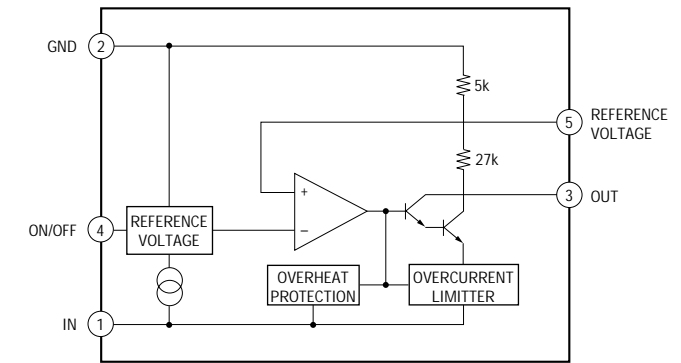

**IC441 LB1641**

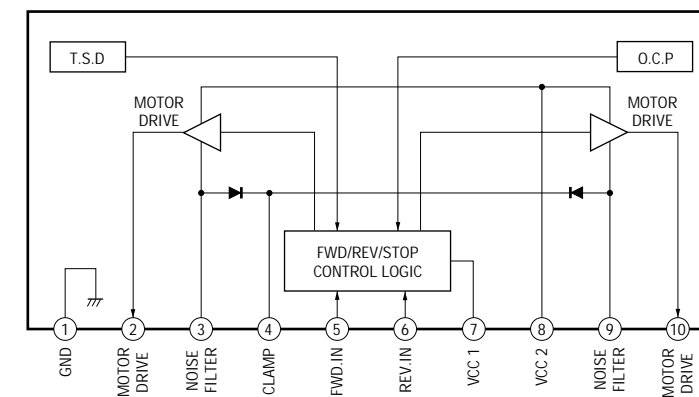

6-10. PRINTED WIRING BOARDS – TRANS Board – • See page 41 for Circuit Boards Location.

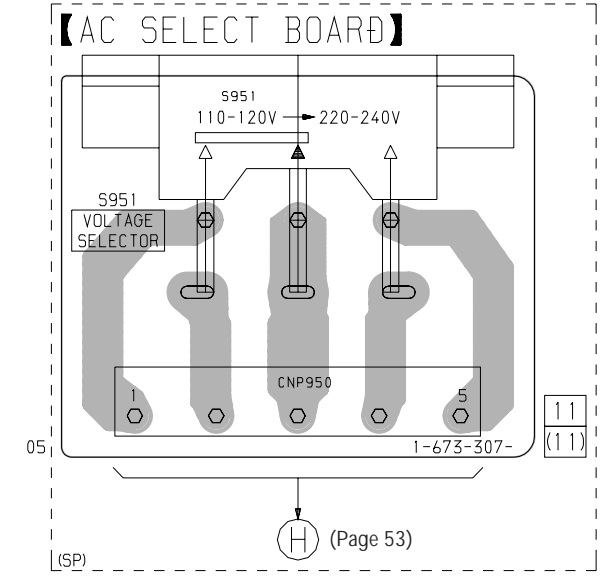
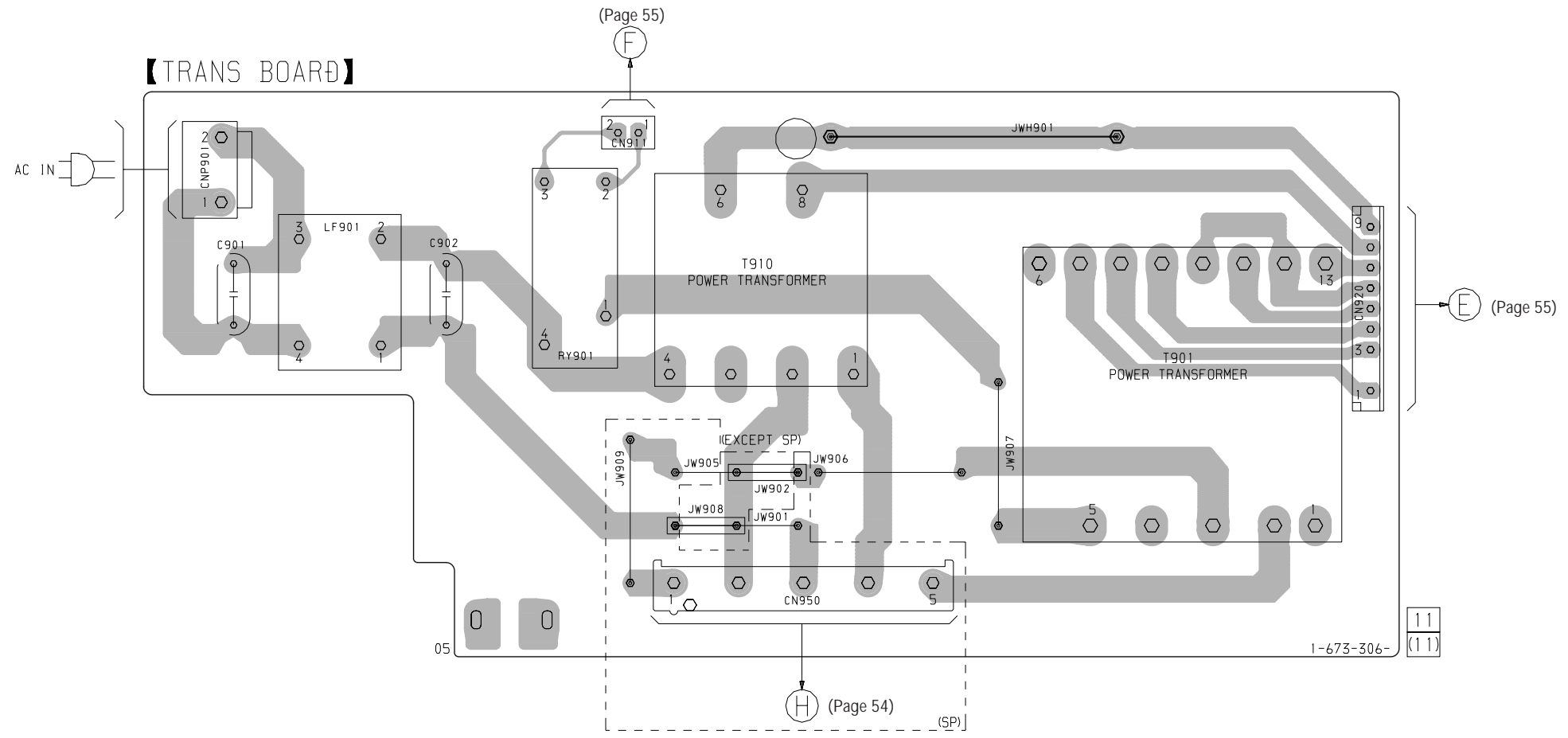

6-11. PRINTED WIRING BOARD – MAIN Board – • See page 41 for Circuit Boards Location.

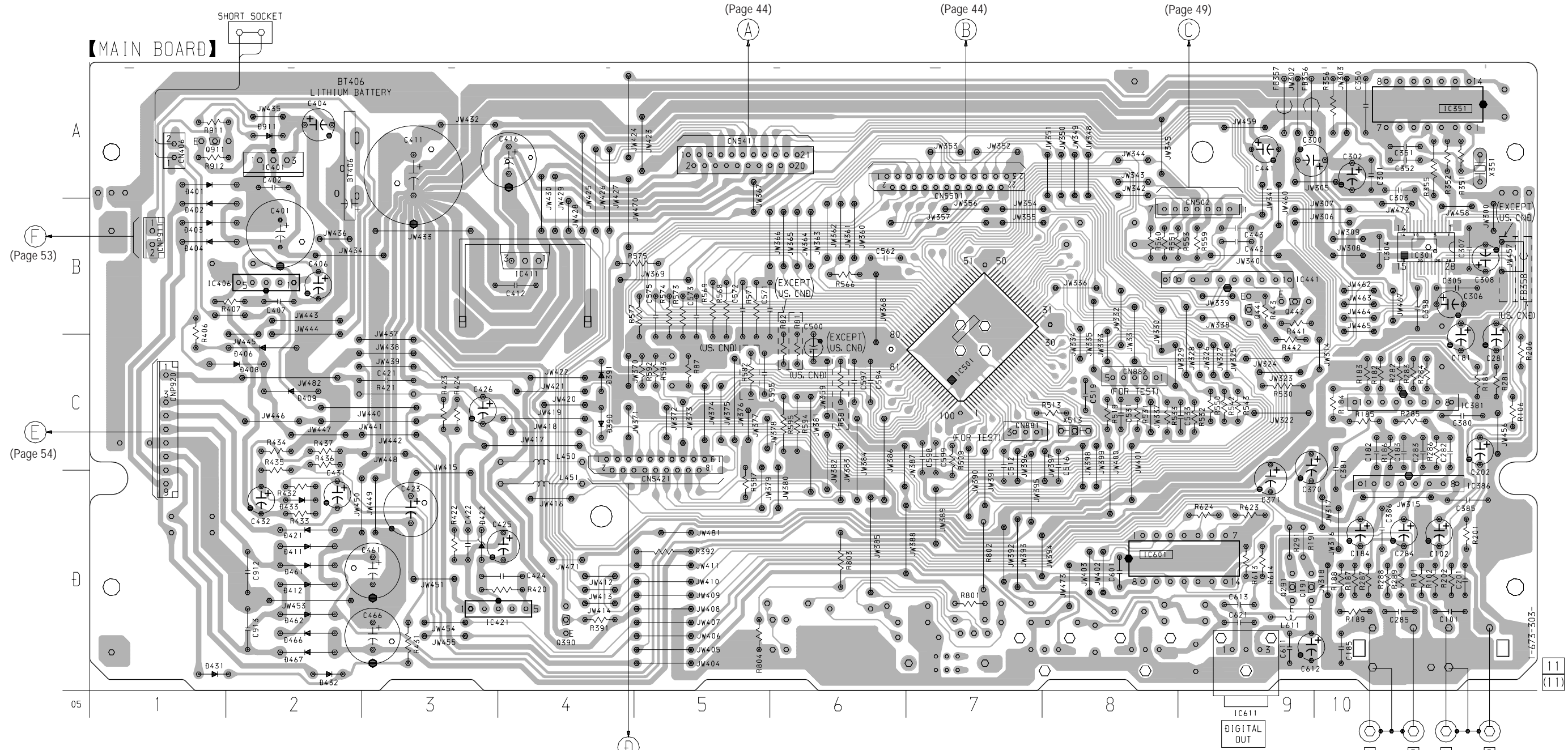

• Semiconductor Location

Ref. No.	Location	Ref. No.	Location
D390	C-4	IC301	B-10
D391	C-4	IC351	A-10
D401	A-1	IC381	C-10
D402	B-1	IC386	D-10
D403	B-1	IC401	A-2
D404	B-1	IC406	B-2
D406	C-2	IC411	B-4
D408	C-2	IC421	D-3
D409	C-2	IC441	B-9
D411	D-2	IC501	C-7
D412	D-2	IC601	D-9
D421	D-2	IC611	D-9
D422	D-3		
D431	D-1	Q191	D-9
D432	D-2	Q291	D-9
D433	D-2	Q390	D-4
D461	D-2	Q441	B-9
D462	D-2	Q442	B-9
D466	D-2	Q911	A-1
D467	D-2		
D911	A-2		

6-12. SCHEMATIC DIAGRAM – MAIN Board (1/2) – • See page 65 for Waveform.

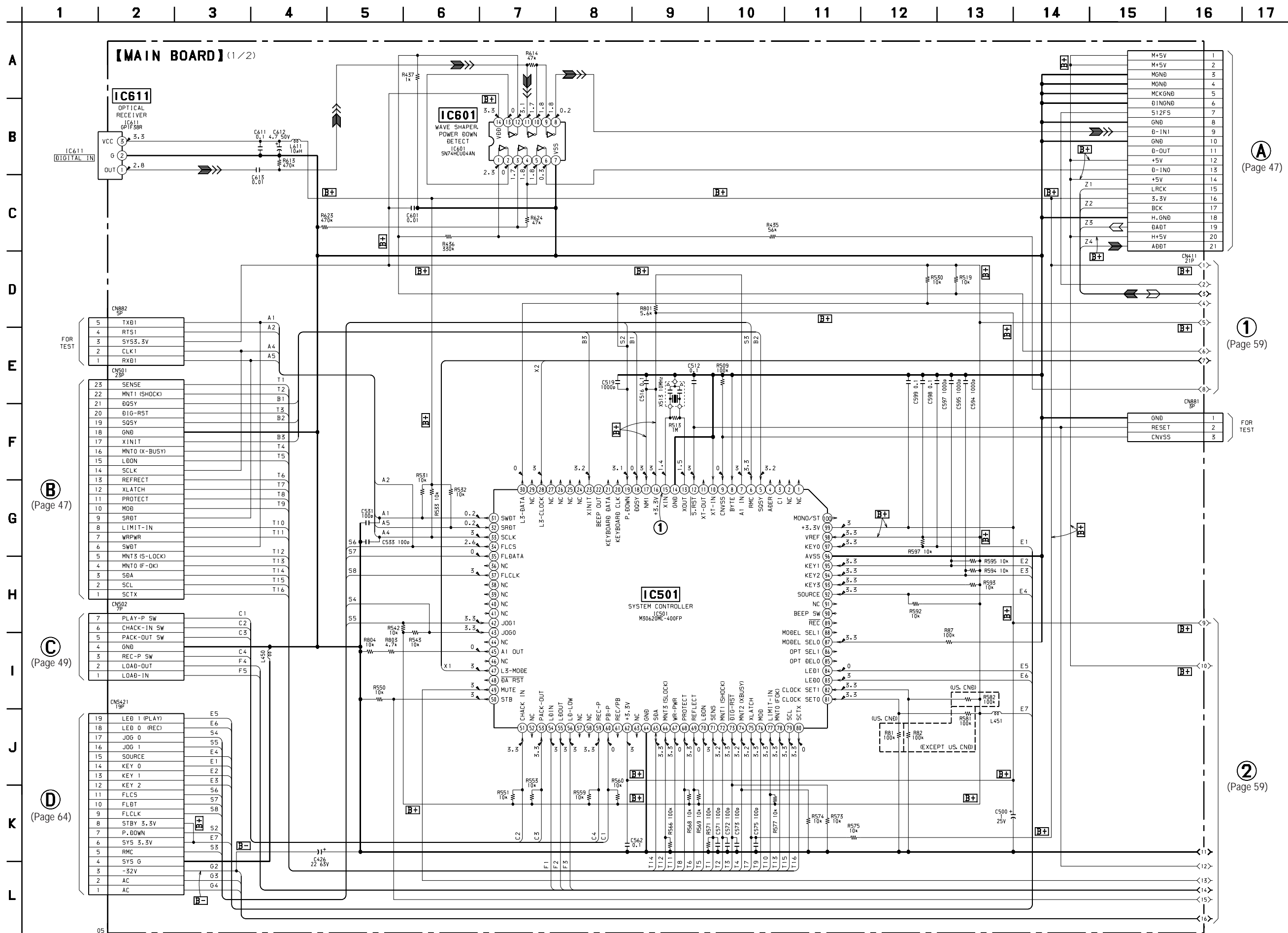

(Page 47)

(Page 59)

(Page 59)

• Voltages and waveforms are dc with respect to ground under no-signal conditions. no mark : PLAY

6-13. SCHEMATIC DIAGRAM – MAIN Board (2/2), TRANS Board – • See page 65 for Waveforms. • See page 52 for IC Block Diagrams.

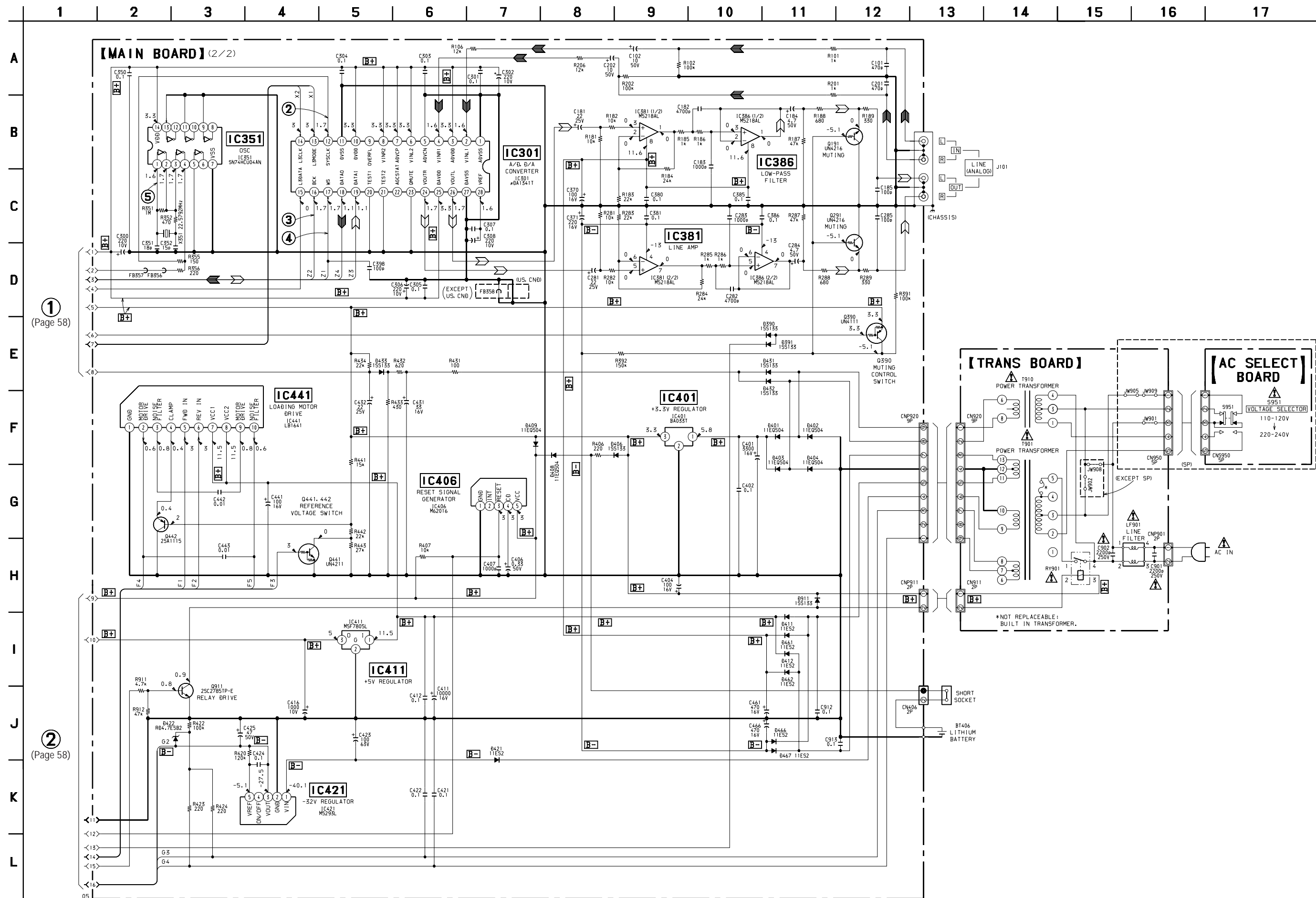

The components identified by mark  $\Delta$  or dotted line with mark  $\Delta$  are critical for safety. Replace only with part number specified.

Les composants identifiés par une marque  $\Delta$  sont critiques pour la sécurité. Ne les remplacer que par une pièce portant le numéro spécifié.

• Voltages and waveforms are dc with respect to ground under no-signal conditions.  
no mark : PLAY

6-14. PRINTED WIRING BOARDS – PANEL/PANEL 2 Boards – • See page 41 for Circuit Boards Location.

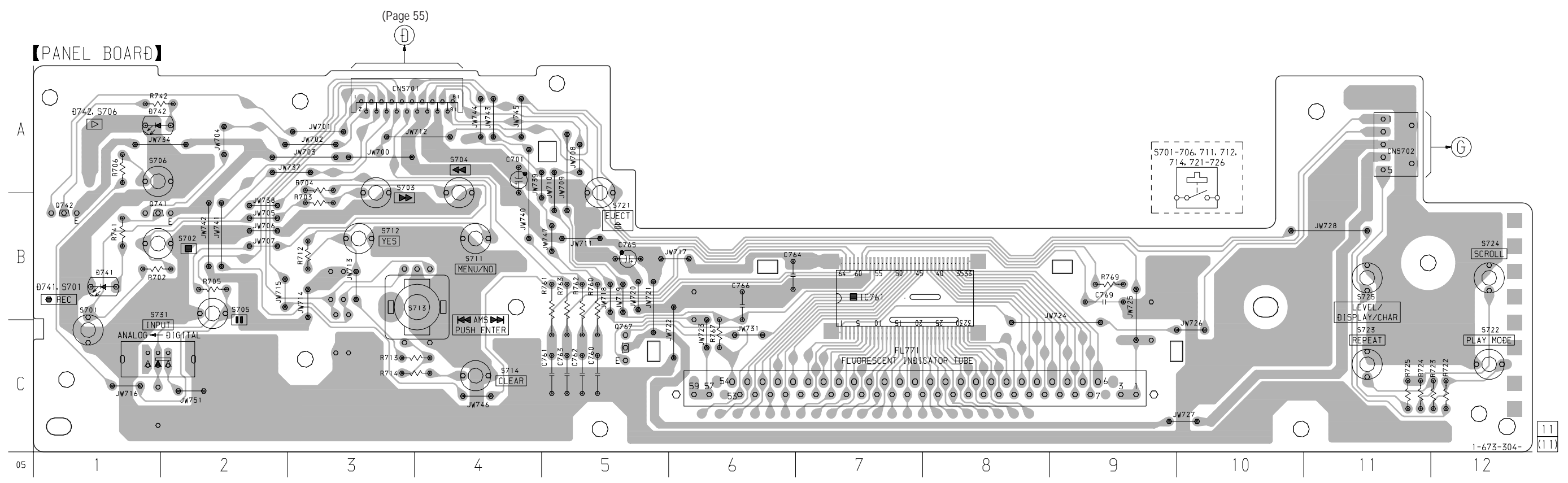

• Semiconductor Location

Ref. No.	Location
D741	B-1
D742	A-1
IC761	B-7
Q741	B-1
Q742	B-1
Q767	C-5

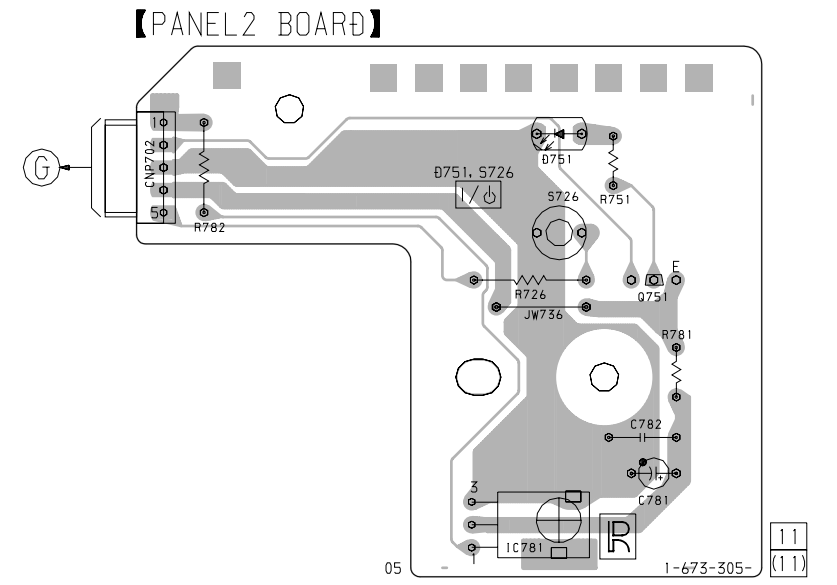



6-15. SCHEMATIC DIAGRAM – PANEL/PANEL 2 Boards – • See page 65 for Waveform.

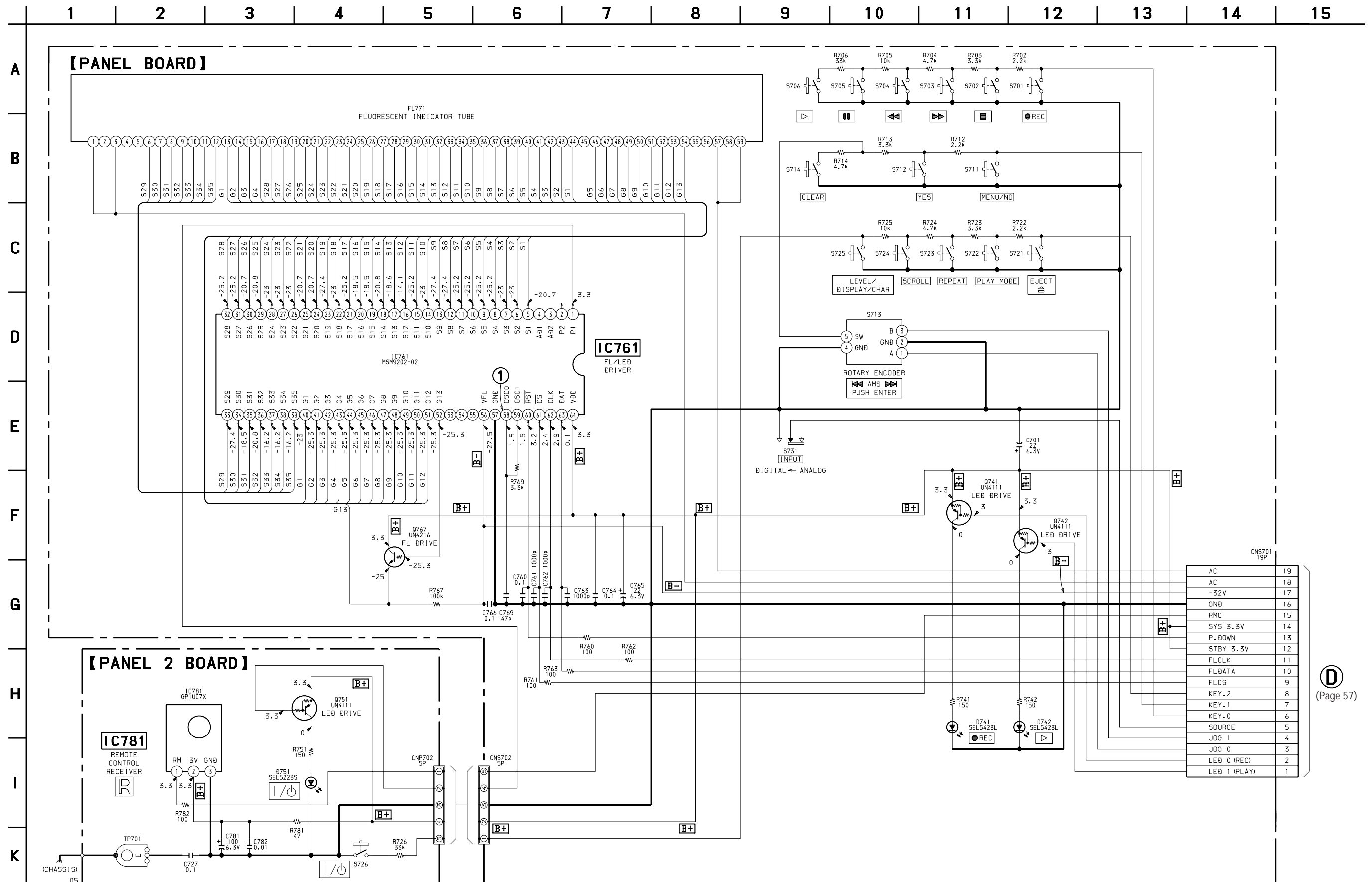

• Voltages and waveforms are dc with respect to ground under no-signal conditions.  
no mark : STOP

• Waveforms  
– BD Board –

① IC101 ①, ② (I, J) (Play mode)

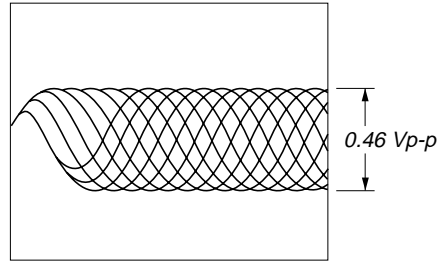

② IC101 ④ (A) (Play mode)

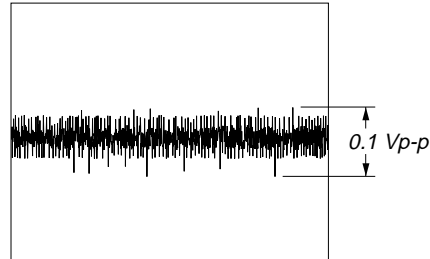

③ IC101 ⑧, ⑨ (E, F) (Play mode)

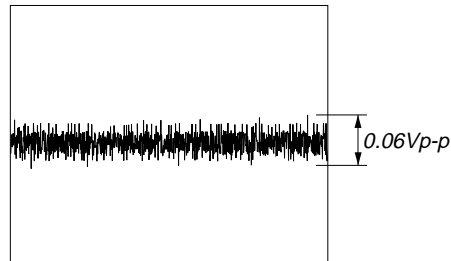

④ IC121 ⑩ (OSCI)

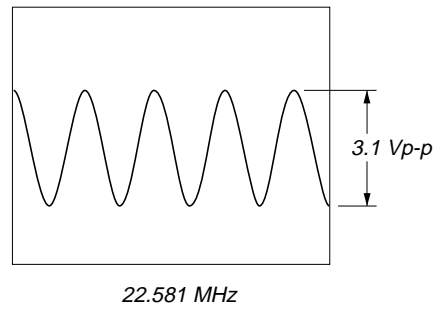

⑤ IC121 ⑰ (LRCK)

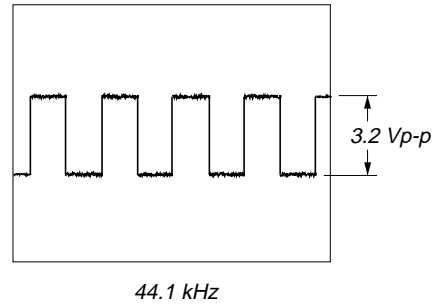

⑥ IC121 ⑳ (XBCK)

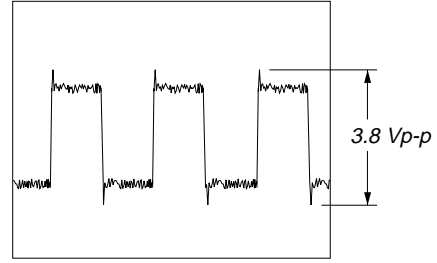

⑦ IC121 ㉑ (FS256)

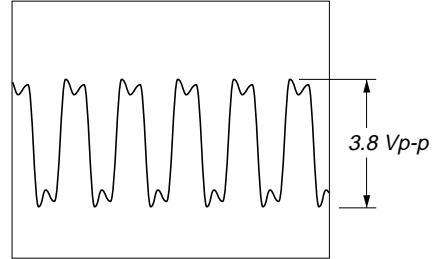

⑧ IC121 ㉒ (FS4)

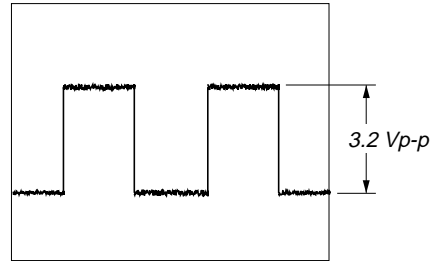

– MAIN Board –

① IC501 ⑩ (XIN)

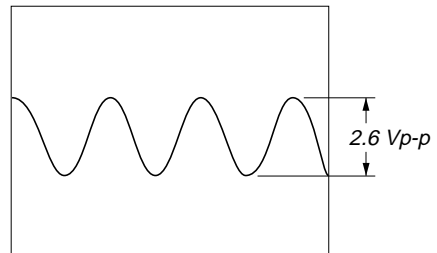

② IC301 ⑫ (SYSCLK)

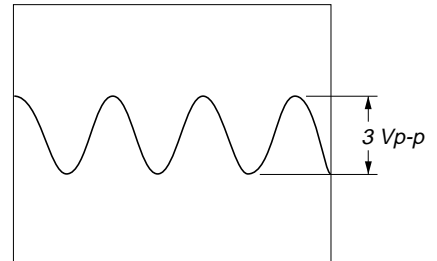

③ IC301 ⑯ (BCK)

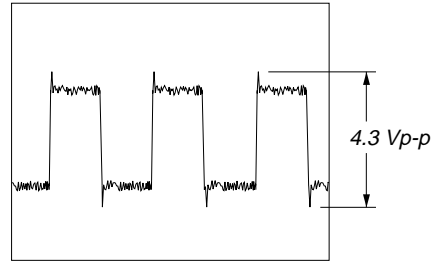

④ IC301 ⑰ (WS)

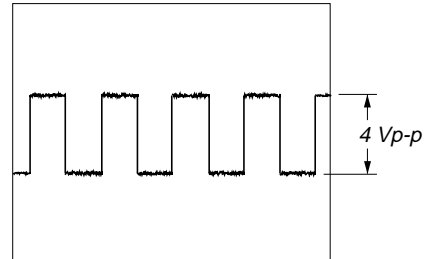

⑤ IC351 ①

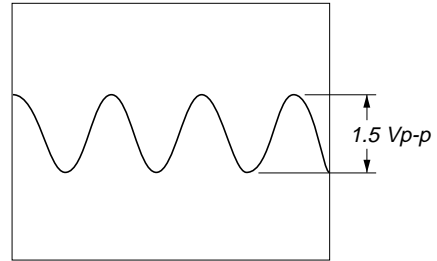

– PANEL Board –

① IC761 ⑧ (OSC0)

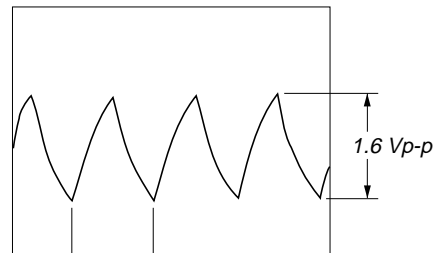

## SECTION 7 EXPLODED VIEWS

NOTE:

- XX and -X mean standardized parts, so they may have some difference from the original one.
- Color Indication of Appearance Parts  
Example:  
KNOB, BALANCE (WHITE) . . . (RED)  
Parts Color Cabinet's Color
- Abbreviation  
CND : Canadian model  
SP : Singapore model

- Items marked "\*" are not stocked since they are seldom required for routine service. Some delay should be anticipated when ordering these items.
- The mechanical parts with no reference number in the exploded views are not supplied.
- Hardware (# mark) list and accessories and packing materials are given in the last of the electrical parts list.

The components identified by mark  $\Delta$  or dotted line with mark  $\Delta$  are critical for safety. Replace only with part number specified.

Les composants identifiés par une marque  $\Delta$  sont critiques pour la sécurité. Ne les remplacer que par une pièce portant le numéro spécifié.

### (1) COVER SECTION

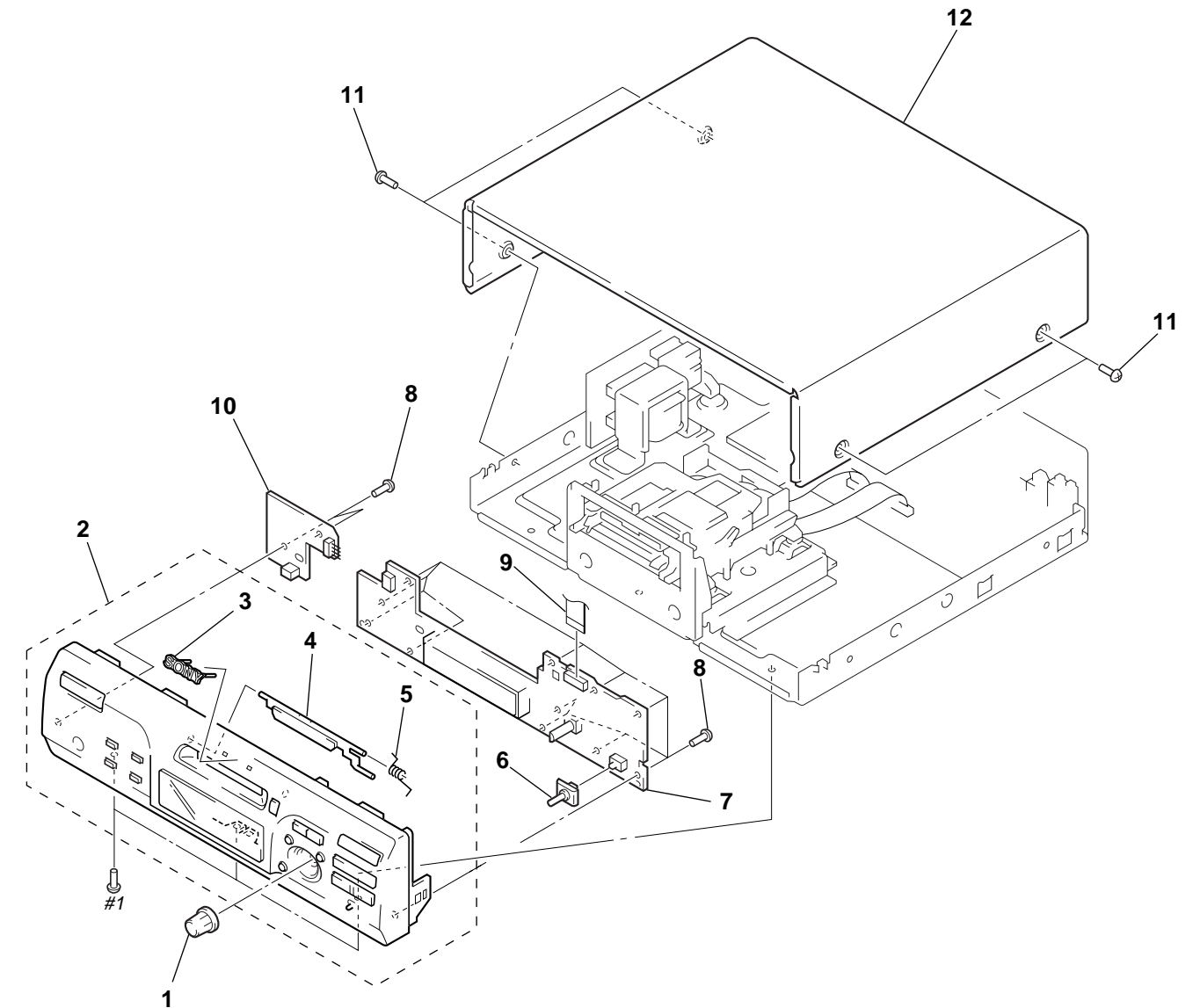

Ref. No.	Part No.	Description	Remark	Ref. No.	Part No.	Description	Remark
1	4-216-828-01	KNOB (AMS)		* 7	A-4724-590-A	PANEL BOARD, COMPLETE	
2	X-4951-046-1	FRONT PANEL ASSY		8	4-951-620-01	SCREW (2.6X8), +BVTP	
3	4-996-698-01	EMBLEM, SONY		9	1-790-510-11	WIRE (FLAT TYPE) (19 CORE)	
4	4-996-690-12	LID (CARTRIDGE)		* 10	1-673-305-11	PANEL 2 BOARD	
5	4-976-593-11	SPRING (LID), TORSION		11	3-363-099-01	SCREW (CASE 3 TP2)	
6	4-989-517-21	KNOB (INPUT)		* 12	4-216-839-01	COVER	

## (2) CHASSIS SECTION

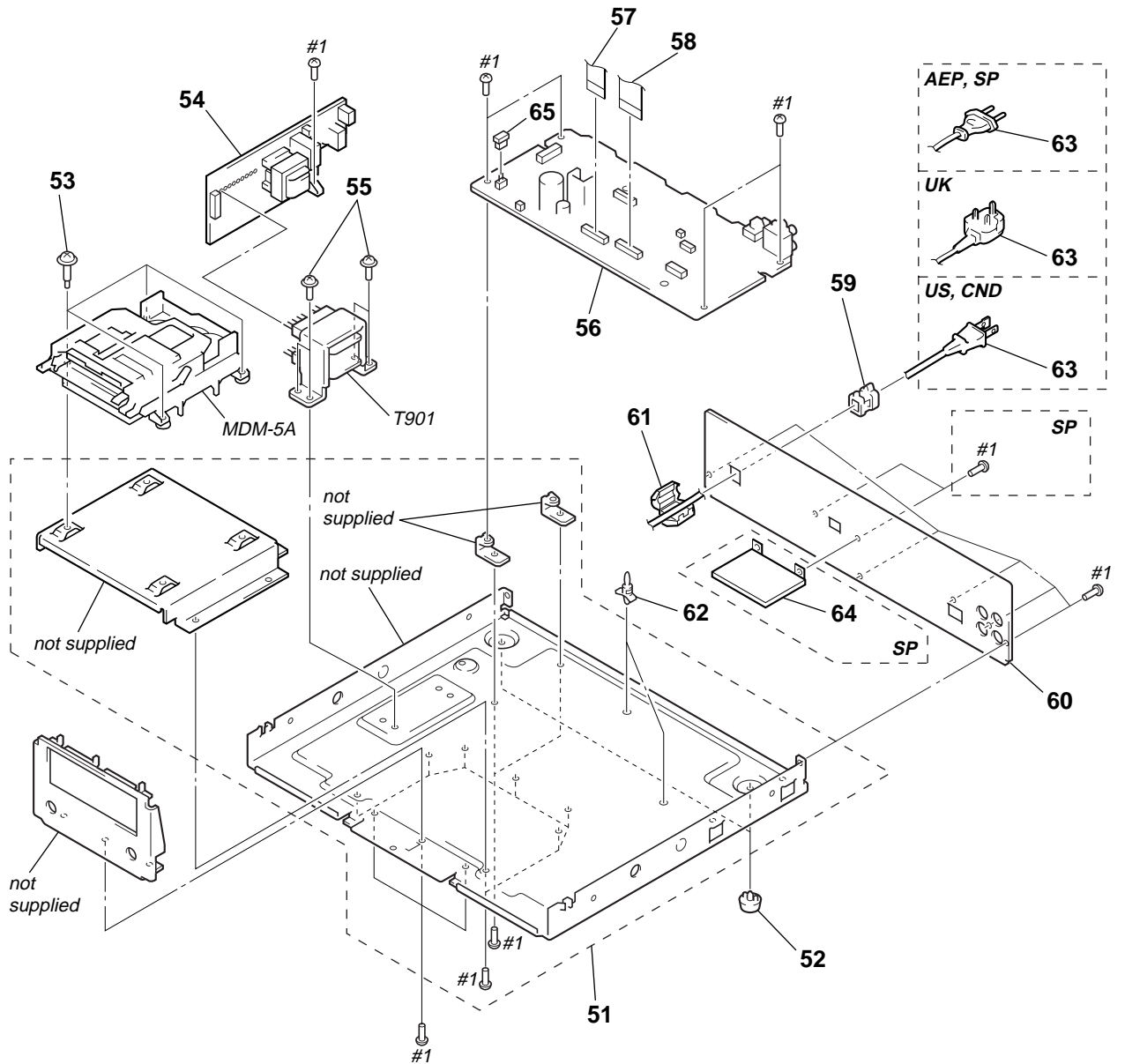

The components identified by mark  $\Delta$  or dotted line with mark  $\Delta$  are critical for safety. Replace only with part number specified.

Les composants identifiés par une marque  $\Delta$  sont critiques pour la sécurité. Ne les remplacer que par une pièce portant le numéro spécifié.

Ref. No.	Part No.	Description	Remark	Ref. No.	Part No.	Description	Remark
* 51	X-4951-211-1	CHASSIS ASSY		* 60	4-216-840-21	BACK PANEL (SP)	
52	4-965-822-01	FOOT		* 60	4-216-840-31	BACK PANEL (AEP)	
53	4-999-839-01	SCREW (+BVTTWH M3), STEP		* 60	4-216-840-41	BACK PANEL (UK)	
* 54	1-673-306-11	TRANS BOARD		61	1-500-051-11	BEAD, FERRITE (WITH CASE)	
55	3-703-249-01	SCREW, S TIGHT, +PTTWH 3X6		62	4-943-687-01	HOLDER, PC BOARD	
* 56	A-4724-589-A	MAIN BOARD, COMPLETE (US, CND)		$\Delta$ 63	1-696-586-21	CORD, POWER (UK)	
* 56	A-4724-628-A	MAIN BOARD, COMPLETE (SP)		$\Delta$ 63	1-777-071-31	CORD, POWER (AEP, SP)	
* 56	A-4724-631-A	MAIN BOARD, COMPLETE (AEP, UK)		$\Delta$ 63	1-783-531-31	CORD, POWER (US, CND)	
57	1-790-512-11	WIRE (FLAT TYPE) (21 CORE)		* 64	1-673-307-11	AC SELECT BOARD (SP)	
58	1-790-513-11	WIRE (FLAT TYPE) (23 CORE)		65	1-569-972-21	SOCKET, SHORT 2P	
* 59	3-703-244-00	BUSHING (2104), CORD		$\Delta$ T901	1-433-697-11	TRANSFORMER, POWER (US, CND)	
* 60	4-216-840-01	BACK PANEL (US)		$\Delta$ T901	1-433-698-11	TRANSFORMER, POWER (AEP, UK)	
* 60	4-216-840-11	BACK PANEL (CND)		$\Delta$ T901	1-433-699-11	TRANSFORMER, POWER (SP)	

**(3) MECHANISM SECTION  
(MDM-5A)**

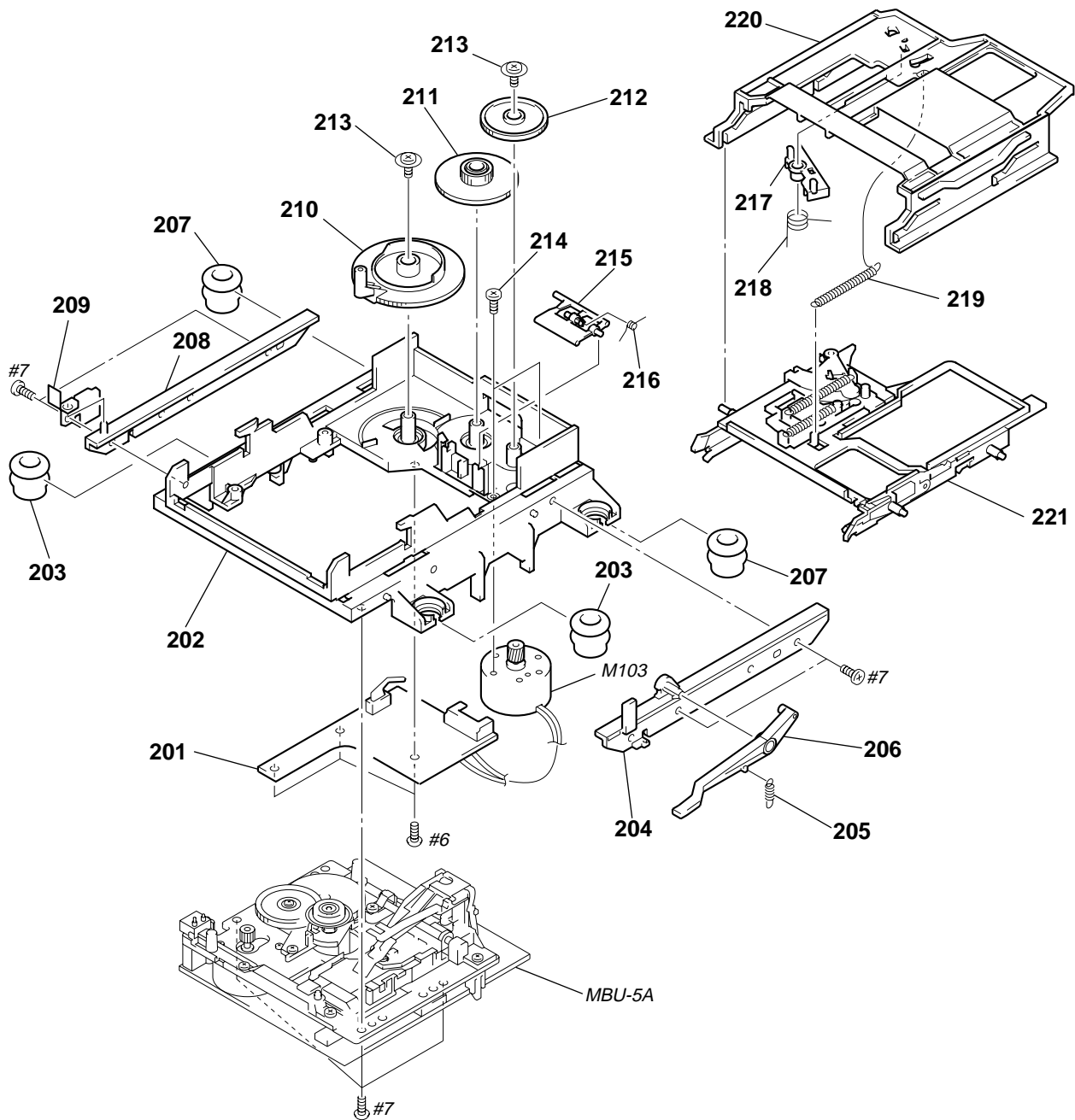

<u>Ref. No.</u>	<u>Part No.</u>	<u>Description</u>	<u>Remark</u>	<u>Ref. No.</u>	<u>Part No.</u>	<u>Description</u>	<u>Remark</u>
* 201	1-668-111-11	SW BOARD		212	4-996-221-01	GEAR (B)	
* 202	4-996-217-01	CHASSIS		213	4-933-134-01	SCREW (+PTPWH M2.6X6)	
203	4-996-223-11	INSULATOR (F) (BLACK)		214	4-996-224-01	SCREW (1.7X3), +PWH	
* 204	4-996-218-01	BRACKET (GUIDE R)		215	4-996-227-01	LEVER (HEAD)	
205	4-996-277-01	SPRING (O/C), TENSION		216	4-996-229-01	SPRING (HEAD LEVER), TORSION	
206	4-996-226-01	LEVER (O/C)		217	4-996-212-01	LEVER (LIMITTER)	
207	4-999-347-01	INSULATOR (R) (GREEN)		218	4-996-213-01	SPRING (LIMITTER), TORSION	
* 208	4-996-225-01	BRACKET (GUIDE L)		219	4-996-216-01	SPRING (HOLDER), TENSION	
209	4-988-466-11	SPRING (ELECTROSTATIC), LEAF		* 220	4-996-211-01	SLIDER (CAM)	
210	4-996-219-01	GEAR (CAM GEAR)		221	A-4680-409-A	HOLDER COMPLETE ASSY	
211	4-996-220-01	GEAR (A)		M103	X-4949-670-1	MOTOR ASSY, LOADING	

**(4) BASE UNIT SECTION  
(MBU-5A)**

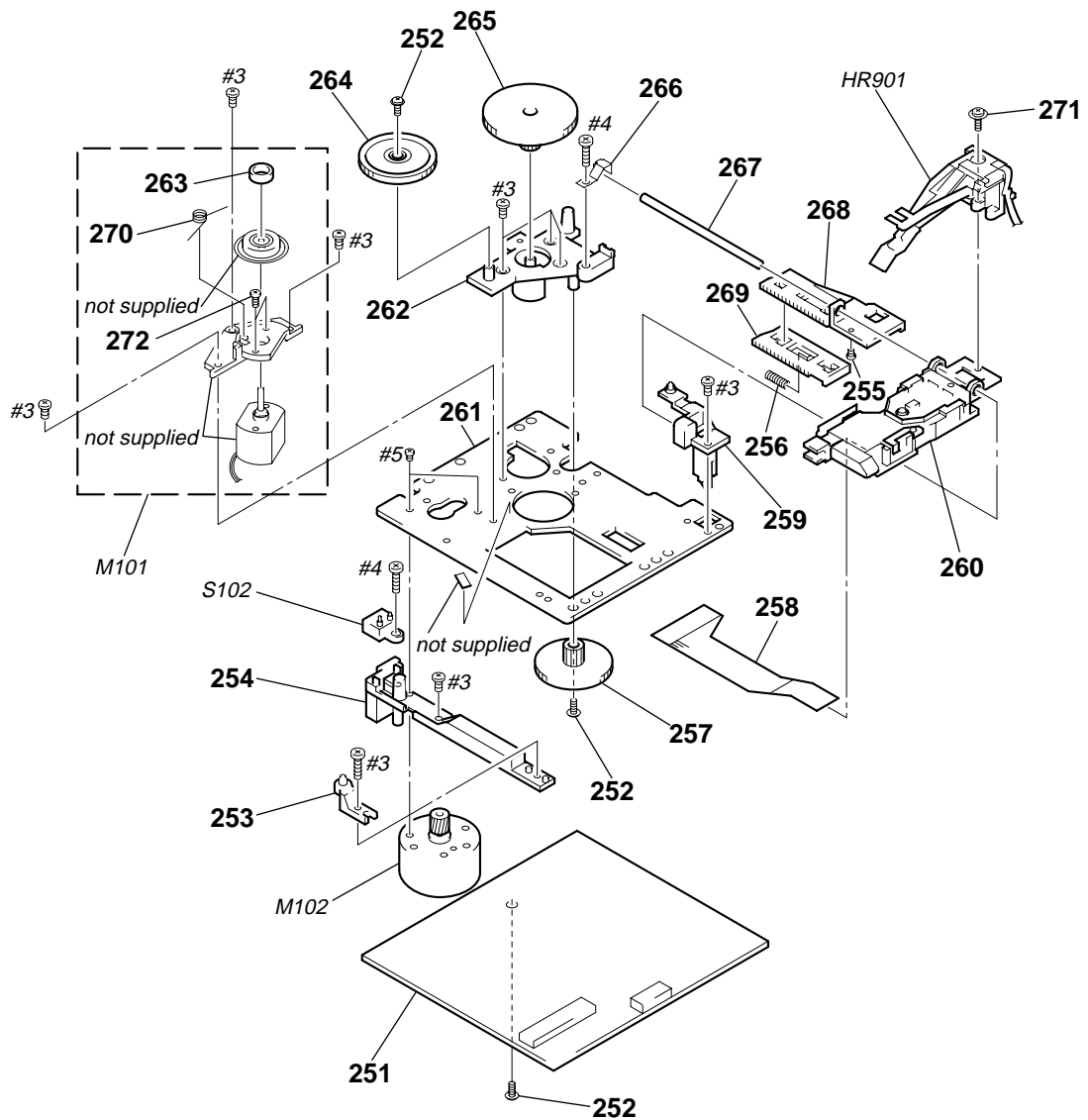

<p>The components identified by mark ▲ or dotted line with mark ▲ are critical for safety. Replace only with part number specified.</p>	<p>Les composants identifiés par une marque ▲ sont critiques pour la sécurité. Ne les remplacer que par une pièce portant le numéro spécifié.</p>
---	---

Ref. No.	Part No.	Description	Remark	Ref. No.	Part No.	Description	Remark
251	A-4724-063-A	BD BOARD, COMPLETE		264	4-996-260-01	GEAR (SL-A)	
252	3-372-761-01	SCREW (M1.7), TAPPING		265	4-996-261-01	GEAR (SL-B)	
* 253	4-996-267-01	BASE (BU-D)		266	4-996-264-01	SPRING (SHAFT), LEAF	
* 254	4-996-255-01	BASE (BU-C)		267	4-996-265-01	SHAFT, MAIN	
255	4-900-590-01	SCREW, PRECISION SMALL		268	4-996-256-11	SL (BASE)	
256	4-996-258-01	SPRING, COMPRESSION		269	4-996-257-01	RACK (SL)	
257	4-996-262-01	GEAR (SL-C)		270	4-996-263-01	SPRING (CLV), TORSION	
* 258	1-667-954-11	FLEXIBLE BOARD		271	4-988-560-01	SCREW (+P 1.7X6)	
* 259	4-210-664-11	BASE (BU-A)		272	4-211-036-01	SCREW (1.7X2.5), +PWH	
▲ 260	8-583-028-02	OPTICAL PICK-UP KMS-260A/J1N		HR901	1-500-502-11	HEAD, OVER WRITE	
* 261	4-996-252-01	CHASSIS, BU		M101	A-4672-516-A	MOTOR ASSY, SPINDLE	
* 262	4-996-254-01	BASE (BU-B)		M102	A-4672-515-A	MOTOR ASSY, SLED	
263	4-967-688-11	MAGNET, ABSORPTION		S102	1-762-148-21	SWITCH, PUSH (2 KEY)	

(REFLECT DET, PROTECT DET)

## SECTION 8 ELECTRICAL PARTS LIST

## NOTE:

- Due to standardization, replacements in the parts list may be different from the parts specified in the diagrams or the components used on the set.
- -XX and -X mean standardized parts, so they may have some difference from the original one.
- RESISTORS  
All resistors are in ohms.  
METAL: Metal-film resistor.  
METAL OXIDE: Metal oxide-film resistor.  
F: nonflammable
- Abbreviation  
CND : Canadian model  
SP : Singapore model

- Items marked “\*” are not stocked since they are seldom required for routine service. Some delay should be anticipated when ordering these items.
- SEMICONDUCTORS  
In each case, u:  $\mu$ , for example:  
uA. . :  $\mu$ A. .      uPA. . :  $\mu$ PA. .  
uPB. . :  $\mu$ PB. .    uPC. . :  $\mu$ PC. .  
uPD. . :  $\mu$ PD. .
- CAPACITORS  
uF:  $\mu$ F
- COILS  
uH:  $\mu$ H

The components identified by mark  $\Delta$  or dotted line with mark  $\Delta$  are critical for safety. Replace only with part number specified.

Les composants identifiés par une marque  $\Delta$  sont critiques pour la sécurité. Ne les remplacer que par une pièce portant le numéro spécifié.

When indicating parts by reference number, please include the board.

Ref. No.	Part No.	Description	Remark	Ref. No.	Part No.	Description	Remark
*	1-673-307-11	AC SELECT BOARD (SP) *****		C142	1-163-251-11	CERAMIC CHIP 100PF 5%	50V
		< SWITCH >		C143	1-163-251-11	CERAMIC CHIP 100PF 5%	50V
$\Delta$ S951	1-771-474-11	SWITCH, POWER (VOLTAGE SELECTOR) *****		C144	1-163-251-11	CERAMIC CHIP 100PF 5%	50V
	A-4724-063-A	BD BOARD, COMPLETE *****		C146	1-163-038-00	CERAMIC CHIP 0.1uF 25V	
		< CAPACITOR >		C151	1-126-206-11	ELECT CHIP 100uF 20%	6.3V
C101	1-125-822-11	TANTALUM 10uF 20%	10V	C152	1-163-038-00	CERAMIC CHIP 0.1uF 25V	
C102	1-163-038-00	CERAMIC CHIP 0.1uF	25V	C153	1-163-021-11	CERAMIC CHIP 0.01uF 10%	50V
C103	1-125-822-11	TANTALUM 10uF 20%	10V	C156	1-163-038-00	CERAMIC CHIP 0.1uF 25V	
C104	1-125-822-11	TANTALUM 10uF 20%	10V	C158	1-163-019-00	CERAMIC CHIP 0.0068uF 10%	50V
C105	1-163-021-11	CERAMIC CHIP 0.01uF 10%	50V	C160	1-104-601-11	ELECT CHIP 10uF 20%	10V
C106	1-163-275-11	CERAMIC CHIP 0.001uF 5%	50V	C161	1-104-601-11	ELECT CHIP 10uF 20%	10V
C107	1-163-038-00	CERAMIC CHIP 0.1uF	25V	C163	1-163-021-11	CERAMIC CHIP 0.01uF 10%	50V
C108	1-163-038-00	CERAMIC CHIP 0.1uF	25V	C164	1-163-021-11	CERAMIC CHIP 0.01uF 10%	50V
C109	1-163-037-11	CERAMIC CHIP 0.022uF 10%	25V	C167	1-163-038-00	CERAMIC CHIP 0.1uF 25V	
C111	1-164-344-11	CERAMIC CHIP 0.068uF 10%	25V	C168	1-163-038-00	CERAMIC CHIP 0.1uF 25V	
C112	1-163-017-00	CERAMIC CHIP 0.0047uF 5%	50V	C169	1-125-822-11	TANTALUM 10uF 20%	10V
C113	1-109-982-11	CERAMIC CHIP 1uF 10%	10V	C171	1-163-038-00	CERAMIC CHIP 0.1uF 25V	
C115	1-164-489-11	CERAMIC CHIP 0.22uF 10%	16V	C181	1-104-913-11	TANTALUM CHIP 10uF 20%	16V
C116	1-163-037-11	CERAMIC CHIP 0.022uF 10%	25V	C183	1-163-038-00	CERAMIC CHIP 0.1uF 25V	
C117	1-163-809-11	CERAMIC CHIP 0.047uF 10%	25V	C184	1-117-970-11	ELECT CHIP 22uF 20%	10V
C118	1-163-038-00	CERAMIC CHIP 0.1uF	25V	C185	1-164-611-11	CERAMIC CHIP 0.001uF 10%	500V
C119	1-125-822-11	TANTALUM 10uF 20%	10V	C187	1-104-913-11	TANTALUM CHIP 10uF 20%	16V
C121	1-125-822-11	TANTALUM 10uF 20%	10V	C188	1-163-021-11	CERAMIC CHIP 0.01uF 10%	50V
C122	1-163-021-11	CERAMIC CHIP 0.01uF 10%	50V	C189	1-163-989-11	CERAMIC CHIP 0.033uF 10%	25V
C123	1-163-038-00	CERAMIC CHIP 0.1uF	25V	C190	1-126-206-11	ELECT CHIP 100uF 20%	6.3V
C124	1-163-038-00	CERAMIC CHIP 0.1uF	25V	C191	1-163-038-00	CERAMIC CHIP 0.1uF 25V	
C127	1-163-038-00	CERAMIC CHIP 0.1uF	25V	C196	1-163-038-00	CERAMIC CHIP 0.1uF 25V	
C128	1-163-021-11	CERAMIC CHIP 0.01uF 10%	50V	C197	1-163-038-00	CERAMIC CHIP 0.1uF 25V	
C129	1-107-823-11	CERAMIC CHIP 0.47uF 10%	16V			< CONNECTOR >	
C130	1-163-251-11	CERAMIC CHIP 100PF 5%	50V	CN101	1-569-479-51	CONNECTOR, FPC 21P	
C131	1-163-023-00	CERAMIC CHIP 0.015uF 5%	50V	CN102	1-784-833-21	CONNECTOR, FFC (LIF (NON-ZIF)) 21P	
C132	1-107-823-11	CERAMIC CHIP 0.47uF 10%	16V	CN103	1-784-834-21	CONNECTOR, FFC (LIF (NON-ZIF)) 23P	
C133	1-163-017-00	CERAMIC CHIP 0.0047uF 5%	50V	CN104	1-770-687-11	CONNECTOR, FFC/FPC 4P	
C134	1-163-038-00	CERAMIC CHIP 0.1uF	25V	CN110	1-695-440-21	PIN, CONNECTOR (PC BOARD) 6P	
C135	1-163-038-00	CERAMIC CHIP 0.1uF	25V			< DIODE >	
C136	1-126-206-11	ELECT CHIP 100uF 20%	6.3V	D101	8-719-988-61	DIODE 1SS355TE-17	
				D181	8-719-046-86	DIODE F1J6TP	
				D183	8-719-046-86	DIODE F1J6TP	

The components identified by mark  $\Delta$  or dotted line with mark  $\Delta$  are critical for safety. Replace only with part number specified.

Les composants identifiés par une marque  $\Delta$  sont critiques pour la sécurité. Ne les remplacer que par une pièce portant le numéro spécifié.

Ref. No.	Part No.	Description	Remark	Ref. No.	Part No.	Description	Remark
< IC/TRANSISTOR >							
IC101	8-752-080-95	IC CXA2523AR		R132	1-216-097-91	RES, CHIP 100K 5%	1/10W
IC103	8-729-903-10	TRANSISTOR FMW1		R133	1-216-117-00	METAL CHIP 680K 5%	1/10W
IC121	8-752-389-44	IC CXD2654R		R134	1-216-049-11	RES, CHIP 1K 5%	1/10W
IC123	8-759-096-87	IC TC7WU04FU (TE12R)		R135	1-216-061-00	METAL CHIP 3.3K 5%	1/10W
IC124	8-759-334-38	IC MSM51V4400-70TS-K		R136	1-216-049-11	RES, CHIP 1K 5%	1/10W
IC152	8-759-430-25	IC BH6511FS-E2		R137	1-216-295-00	SHORT 0	
IC171	8-759-487-04	IC BR24C02F-E2		R140	1-216-029-00	METAL CHIP 150 5%	1/10W
IC181	8-759-481-17	IC MC74ACT08DTR2		R142	1-216-073-00	METAL CHIP 10K 5%	1/10W
IC192	8-759-460-72	IC BA033FP-E2		R143	1-216-073-00	METAL CHIP 10K 5%	1/10W
				R144	1-216-025-00	RES, CHIP 100 5%	1/10W
< COIL/SHORT >							
L101	1-414-813-11	FERRITE 0uH		R145	1-216-073-00	METAL CHIP 10K 5%	1/10W
L102	1-414-813-11	FERRITE 0uH		R146	1-216-037-00	METAL CHIP 330 5%	1/10W
L103	1-414-813-11	FERRITE 0uH		R147	1-216-025-00	RES, CHIP 100 5%	1/10W
L105	1-414-813-11	FERRITE 0uH		R148	1-216-045-00	METAL CHIP 680 5%	1/10W
L106	1-414-813-11	FERRITE 0uH		R149	1-216-073-00	METAL CHIP 10K 5%	1/10W
L121	1-414-813-11	FERRITE 0uH		R150	1-216-295-00	SHORT 0	
L122	1-414-813-11	FERRITE 0uH		R151	1-216-073-00	METAL CHIP 10K 5%	1/10W
L151	1-412-029-11	INDUCTOR CHIP 10uH		R152	1-216-073-00	METAL CHIP 10K 5%	1/10W
L152	1-412-029-11	INDUCTOR CHIP 10uH		R158	1-216-097-91	RES, CHIP 100K 5%	1/10W
L153	1-412-032-11	INDUCTOR CHIP 100uH		R159	1-216-097-91	RES, CHIP 100K 5%	1/10W
L154	1-412-032-11	INDUCTOR CHIP 100uH		R160	1-216-295-00	SHORT 0	
L161	1-414-813-11	FERRITE 0uH		R161	1-216-057-00	METAL CHIP 2.2K 5%	1/10W
L162	1-414-813-11	FERRITE 0uH		R162	1-216-057-00	METAL CHIP 2.2K 5%	1/10W
L181	1-216-295-00	SHORT 0		R163	1-216-057-00	METAL CHIP 2.2K 5%	1/10W
				R164	1-216-045-00	METAL CHIP 680 5%	1/10W
< TRANSISTOR >							
Q101	8-729-028-91	TRANSISTOR DTA144EUA-T106		R165	1-216-097-91	RES, CHIP 100K 5%	1/10W
Q102	8-729-026-53	TRANSISTOR 2SA1576A-T106-QR		R166	1-220-149-11	RESISTOR 2.2 10%	1/2W
Q103	8-729-028-99	TRANSISTOR RN1307-TE85L		R167	1-216-065-00	RES, CHIP 4.7K 5%	1/10W
Q104	8-729-028-99	TRANSISTOR RN1307-TE85L		R169	1-219-724-11	METAL CHIP 1 1%	1/4W
Q162	8-729-101-07	TRANSISTOR 2SB798-DL		R170	1-216-073-00	METAL CHIP 10K 5%	1/10W
Q163	8-729-028-91	TRANSISTOR DTA144EUA-T106		R171	1-216-073-00	METAL CHIP 10K 5%	1/10W
Q181	8-729-018-75	FET 2SJ278MY		R173	1-216-121-00	RES, CHIP 1M 5%	1/10W
Q182	8-729-017-65	FET 2SK1764KY		R175	1-216-065-00	RES, CHIP 4.7K 5%	1/10W
				R177	1-216-061-00	METAL CHIP 3.3K 5%	1/10W
				R179	1-216-085-00	METAL CHIP 33K 5%	1/10W
< RESISTOR >							
R103	1-216-049-11	RES, CHIP 1K 5%	1/10W	R180	1-216-073-00	METAL CHIP 10K 5%	1/10W
R104	1-216-073-00	METAL CHIP 10K 5%	1/10W	R182	1-216-089-00	RES, CHIP 47K 5%	1/10W
R105	1-216-065-00	RES, CHIP 4.7K 5%	1/10W	R183	1-216-089-00	RES, CHIP 47K 5%	1/10W
R106	1-216-133-00	METAL CHIP 3.3M 5%	1/10W	R184	1-216-073-00	METAL CHIP 10K 5%	1/10W
R107	1-216-113-00	METAL CHIP 470K 5%	1/10W	R185	1-216-081-00	METAL CHIP 22K 5%	1/10W
R109	1-216-295-00	SHORT 0		R186	1-216-089-00	RES, CHIP 47K 5%	1/10W
R110	1-216-073-00	METAL CHIP 10K 5%	1/10W	R188	1-216-073-00	METAL CHIP 10K 5%	1/10W
R111	1-216-295-00	SHORT 0		R189	1-216-073-00	METAL CHIP 10K 5%	1/10W
R112	1-216-089-00	RES, CHIP 47K 5%	1/10W	R190	1-216-073-00	METAL CHIP 10K 5%	1/10W
R113	1-216-049-11	RES, CHIP 1K 5%	1/10W	R195	1-216-073-00	METAL CHIP 10K 5%	1/10W
R115	1-216-049-11	RES, CHIP 1K 5%	1/10W	R196	1-216-295-00	SHORT 0	
R117	1-216-113-00	METAL CHIP 470K 5%	1/10W	R197	1-216-295-00	SHORT 0	
R120	1-216-025-00	RES, CHIP 100 5%	1/10W	< SWITCH >			
R121	1-216-097-91	RES, CHIP 100K 5%	1/10W	S101	1-762-596-21	SWITCH, PUSH (1 KEY) (LIMIT IN)	
R123	1-216-295-00	SHORT 0		S102	1-762-148-21	SWITCH, PUSH (2 KEY) (REFLECT DET, PROTECT DET)	
R124	1-216-025-00	RES, CHIP 100 5%	1/10W	*****			
R125	1-216-025-00	RES, CHIP 100 5%	1/10W				
R127	1-216-025-00	RES, CHIP 100 5%	1/10W				
R129	1-216-295-00	SHORT 0					
R131	1-216-073-00	METAL CHIP 10K 5%	1/10W				

**MAIN**

Ref. No.	Part No.	Description	Remark	Ref. No.	Part No.	Description	Remark
*	A-4724-589-A	MAIN BOARD, COMPLETE (US, CND)		C431	1-126-966-11	ELECT 33uF 20%	50V
*	A-4724-628-A	MAIN BOARD, COMPLETE (SP)		C432	1-128-551-11	ELECT 22uF 20%	25V
*	A-4724-631-A	MAIN BOARD, COMPLETE (AEP, UK)		C441	1-126-933-11	ELECT 100uF 20%	16V
		*****		C442	1-162-306-11	CERAMIC 0.01uF 20%	16V
	7-685-872-09	SCREW +BVTT 3X8 (S)		C443	1-162-306-11	CERAMIC 0.01uF 20%	16V
		< BATTERY >		C461	1-126-964-11	ELECT 10uF 20%	50V
BT406	1-528-887-11	BATTERY, LITHIUM SECONDARY		C466	1-126-964-11	ELECT 10uF 20%	50V
		< CAPACITOR >		C500	1-131-347-00	TANTALUM 1uF 10%	35V
C101	1-162-290-31	CERAMIC 470PF 10%	50V	C512	1-164-159-11	CERAMIC 0.1uF	50V
C102	1-126-964-11	ELECT 10uF 20%	50V	C516	1-164-159-11	CERAMIC 0.1uF	50V
C181	1-128-551-11	ELECT 22uF 20%	25V	C519	1-162-294-31	CERAMIC 0.001uF 10%	50V
C182	1-162-600-11	CERAMIC 0.0047uF 30%	16V	C531	1-162-282-31	CERAMIC 100PF 10%	50V
C183	1-162-294-31	CERAMIC 0.001uF 10%	50V	C533	1-162-282-31	CERAMIC 100PF 10%	50V
C184	1-126-963-11	ELECT 4.7uF 20%	50V	C562	1-164-159-11	CERAMIC 0.1uF	50V
C185	1-162-282-31	CERAMIC 100PF 10%	50V	C571	1-162-282-31	CERAMIC 100PF 10%	50V
C201	1-162-290-31	CERAMIC 470PF 10%	50V	C572	1-162-282-31	CERAMIC 100PF 10%	50V
C202	1-126-964-11	ELECT 10uF 20%	50V	C573	1-162-282-31	CERAMIC 100PF 10%	50V
C281	1-128-551-11	ELECT 22uF 20%	25V	C575	1-162-282-31	CERAMIC 100PF 10%	50V
C282	1-162-600-11	CERAMIC 0.0047uF 30%	16V	C594	1-162-294-31	CERAMIC 0.001uF 10%	50V
C283	1-162-294-31	CERAMIC 0.001uF 10%	50V	C595	1-162-294-31	CERAMIC 0.001uF 10%	50V
C284	1-126-963-11	ELECT 4.7uF 20%	50V	C597	1-162-294-31	CERAMIC 0.001uF 10%	50V
C285	1-162-282-31	CERAMIC 100PF 10%	50V	C598	1-164-159-11	CERAMIC 0.1uF	50V
C300	1-126-934-11	ELECT 220uF 20%	10V	C599	1-164-159-11	CERAMIC 0.1uF	50V
C301	1-164-159-11	CERAMIC 0.1uF	50V	C601	1-162-306-11	CERAMIC 0.01uF 20%	16V
C302	1-126-934-11	ELECT 220uF 20%	10V	C611	1-164-159-11	CERAMIC 0.1uF	50V
C303	1-164-159-11	CERAMIC 0.1uF	50V	C612	1-126-963-11	ELECT 4.7uF 20%	50V
C304	1-164-159-11	CERAMIC 0.1uF	50V	C613	1-162-306-11	CERAMIC 0.01uF 20%	16V
C305	1-164-159-11	CERAMIC 0.1uF	50V	C912	1-164-159-11	CERAMIC 0.1uF	50V
C306	1-126-934-11	ELECT 220uF 20%	10V	C913	1-164-159-11	CERAMIC 0.1uF	50V
C307	1-164-159-11	CERAMIC 0.1uF	50V			< CONNECTOR >	
C308	1-126-934-11	ELECT 220uF 20%	10V	CN406	1-568-683-11	PIN, CONNECTOR (PC BAORD) 2P	
C350	1-164-159-11	CERAMIC 0.1uF	50V	* CN502	1-568-934-11	PIN, CONNECTOR 7P	
C351	1-162-205-31	CERAMIC 18PF 5%	50V	CNP920	1-691-770-11	PLUG (MICRO CONNECTOR) 8P	
C352	1-162-203-31	CERAMIC 15PF 5%	50V	CNS411	1-784-418-11	CONNECTOR, FFC (LIF(NON-ZIF) 21P	
C370	1-126-933-11	ELECT 100uF 20%	16V	CNS421	1-779-287-11	CONNECTOR, FFC (LIF(NON-ZIF))19P	
C371	1-126-934-11	ELECT 220uF 20%	10V	CNS501	1-784-417-11	CONNECTOR, FFC (LIF(NON-ZIF) 23P	
C380	1-164-159-11	CERAMIC 0.1uF	50V			< DIODE >	
C381	1-164-159-11	CERAMIC 0.1uF	50V	D390	8-719-911-19	DIODE 1SS119	
C385	1-164-159-11	CERAMIC 0.1uF	50V	D391	8-719-911-19	DIODE 1SS119	
C386	1-164-159-11	CERAMIC 0.1uF	50V	D401	8-719-210-21	DIODE 11EQS04	
C398	1-162-282-31	CERAMIC 100PF 10%	50V	D402	8-719-210-21	DIODE 11EQS04	
C401	1-126-936-11	ELECT 3300uF 20%	16V	D403	8-719-210-21	DIODE 11EQS04	
C402	1-164-159-11	CERAMIC 0.1uF	50V	D404	8-719-210-21	DIODE 11EQS04	
C404	1-126-933-11	ELECT 100uF 20%	16V	D406	8-719-911-19	DIODE 1SS119	
C406	1-124-252-00	ELECT 0.33uF 20%	50V	D408	8-719-024-99	DIODE 11ES2-NTA2B	
C407	1-162-294-31	CERAMIC 0.001uF 10%	50V	D409	8-719-210-21	DIODE 11EQS04	
C411	1-126-939-11	ELECT 10000uF 20%	16V	D411	8-719-024-99	DIODE 11ES2-NTA2B	
C412	1-164-159-11	CERAMIC 0.1uF	50V	D412	8-719-024-99	DIODE 11ES2-NTA2B	
C416	1-126-926-11	ELECT 1000uF 20%	10V	D421	8-719-024-99	DIODE 11ES2-NTA2B	
C421	1-164-159-11	CERAMIC 0.1uF	50V	D422	8-719-109-81	DIODE RD4.7ESB2	
C422	1-164-159-11	CERAMIC 0.1uF	50V	D431	8-719-911-19	DIODE 1SS119	
C423	1-128-576-11	ELECT 100uF 20%	63V	D432	8-719-911-19	DIODE 1SS119	
C424	1-164-159-11	CERAMIC 0.1uF	50V	D433	8-719-911-19	DIODE 1SS119	
C425	1-126-967-11	ELECT 47uF 20%	50V	D461	8-719-024-99	DIODE 11ES2-NTA2B	
C426	1-128-551-11	ELECT 22uF 20%	63V	D462	8-719-024-99	DIODE 11ES2-NTA2B	



Ref. No.	Part No.	Description	Remark	Ref. No.	Part No.	Description	Remark
D466	8-719-024-99	DIODE 11ES2-NTA2B		R189	1-249-411-11	CARBON 330	5% 1/4W
D467	8-719-024-99	DIODE 11ES2-NTA2B		R201	1-249-417-11	CARBON 1K	5% 1/4W
D911	8-719-911-19	DIODE 1SS119		R202	1-249-441-11	CARBON 100K	5% 1/4W
		< INDUCTOR >		R206	1-249-430-11	CARBON 12K	5% 1/4W
FB356	1-412-473-21	INDUCTOR (SMALL TYPE)		R281	1-249-429-11	CARBON 10K	5% 1/4W
FB357	1-412-473-21	INDUCTOR (SMALL TYPE)		R282	1-249-429-11	CARBON 10K	5% 1/4W
FB358	1-412-473-21	INDUCTOR (SMALL TYPE) (US, CND)		R283	1-249-433-11	CARBON 22K	5% 1/4W
		< IC >		R284	1-247-864-11	CARBON 24K	5% 1/4W
IC301	8-759-553-65	IC UDA1341TS/N2		R285	1-249-417-11	CARBON 1K	5% 1/4W
IC351	8-759-917-18	IC SN74HCU04AN		R286	1-249-417-11	CARBON 1K	5% 1/4W
IC381	8-759-634-50	IC M5218AL		R287	1-249-437-11	CARBON 47K	5% 1/4W
IC386	8-759-634-50	IC M5218AL		R288	1-249-415-11	CARBON 680	5% 1/4W
IC401	8-759-445-59	IC BA033T		R289	1-249-411-11	CARBON 330	5% 1/4W
IC406	8-759-481-02	IC M62016L		R351	1-247-903-00	CARBON 1M	5% 1/4W
IC411	8-759-231-53	IC TA7805S		R352	1-249-413-11	CARBON 470	5% 1/4W
IC421	8-759-633-42	IC M5293L		R355	1-249-407-11	CARBON 150	5% 1/4W
IC441	8-759-822-09	IC LB1641		R356	1-249-409-11	CARBON 220	5% 1/4W
IC501	8-759-577-40	IC M30620MC-400FP		R391	1-249-441-11	CARBON 100K	5% 1/4W
IC601	8-759-917-18	IC SN74HCU04AN		R392	1-247-883-00	CARBON 150K	5% 1/4W
IC611	8-749-012-70	IC GP1F38R (DIGITAL OUT)		R406	1-249-409-11	CARBON 220	5% 1/4W
		< JACK >		R407	1-249-429-11	CARBON 10K	5% 1/4W
J101	1-784-429-11	JACK, PIN 4P (LINE (ANALOG) IN/OUT)		R420	1-247-881-00	CARBON 120K	5% 1/4W
		< COIL >		R422	1-249-441-11	CARBON 100K	5% 1/4W
L450	1-410-509-11	INDUCTOR 10uH		R423	1-249-409-11	CARBON 220	5% 1/4W
L451	1-410-509-11	INDUCTOR 10uH		R424	1-249-409-11	CARBON 220	5% 1/4W
L611	1-410-509-11	INDUCTOR 10uH		R431	1-247-807-31	CARBON 100	5% 1/4W
		< TRANSISTOR >		R432	1-249-826-11	CARBON 620	5% 1/4W
Q191	8-729-900-74	TRANSISTOR DTC143TS		R433	1-247-822-11	CARBON 430	5% 1/4W
Q291	8-729-900-74	TRANSISTOR DTC143TS		R434	1-249-433-11	CARBON 22K	5% 1/4W
Q390	8-729-422-57	TRANSISTOR UN4111		R435	1-249-438-11	CARBON 56K	5% 1/4W
Q441	8-729-900-80	TRANSISTOR DTC114ES		R436	1-247-891-00	CARBON 330K	5% 1/4W
Q442	8-729-119-76	TRANSISTOR 2SA1175-HFE		R437	1-249-417-11	CARBON 1K	5% 1/4W
Q911	8-729-119-78	TRANSISTOR 2SC403SP-51		R441	1-249-431-11	CARBON 15K	5% 1/4W
		< RESISTOR >		R442	1-249-433-11	CARBON 22K	5% 1/4W
R81	1-249-441-11	CARBON 100K 5%	1/4W (US, CND)	R443	1-249-434-11	CARBON 27K	5% 1/4W
R82	1-249-441-11	CARBON 100K 5%	1/4W (EXCEPT US, CND)	R509	1-249-441-11	CARBON 100K	5% 1/4W
R87	1-249-441-11	CARBON 100K 5%	1/4W	R513	1-247-903-00	CARBON 1M	5% 1/4W
R101	1-249-417-11	CARBON 1K 5%	1/4W	R519	1-249-429-11	CARBON 10K	5% 1/4W
R102	1-249-441-11	CARBON 100K 5%	1/4W	R530	1-249-429-11	CARBON 10K	5% 1/4W
R106	1-249-430-11	CARBON 12K 5%	1/4W	R531	1-249-429-11	CARBON 10K	5% 1/4W
R181	1-249-429-11	CARBON 10K 5%	1/4W	R532	1-249-429-11	CARBON 10K	5% 1/4W
R182	1-249-429-11	CARBON 10K 5%	1/4W	R533	1-249-429-11	CARBON 10K	5% 1/4W
R183	1-249-433-11	CARBON 22K 5%	1/4W	R542	1-249-429-11	CARBON 10K	5% 1/4W
R184	1-247-864-11	CARBON 24K 5%	1/4W	R543	1-249-429-11	CARBON 10K	5% 1/4W
R185	1-249-417-11	CARBON 1K 5%	1/4W	R550	1-249-429-11	CARBON 10K	5% 1/4W
R186	1-249-417-11	CARBON 1K 5%	1/4W	R551	1-249-429-11	CARBON 10K	5% 1/4W
R187	1-249-437-11	CARBON 47K 5%	1/4W	R553	1-249-429-11	CARBON 10K	5% 1/4W
R188	1-249-415-11	CARBON 680 5%	1/4W	R559	1-249-429-11	CARBON 10K	5% 1/4W
				R560	1-249-429-11	CARBON 10K	5% 1/4W
				R566	1-249-441-11	CARBON 100K	5% 1/4W
				R568	1-249-429-11	CARBON 10K	5% 1/4W
				R569	1-249-429-11	CARBON 10K	5% 1/4W
				R571	1-249-441-11	CARBON 100K	5% 1/4W
				R573	1-249-429-11	CARBON 10K	5% 1/4W
				R574	1-249-429-11	CARBON 10K	5% 1/4W
				R575	1-249-429-11	CARBON 10K	5% 1/4W
				R577	1-249-429-11	CARBON 10K	5% 1/4W

MAIN

PANEL

PANEL 2

Ref. No.	Part No.	Description	Remark
R581	1-249-441-11	CARBON 100K 5%	1/4W (EXCEPT US, CND)
R582	1-249-441-11	CARBON 100K 5%	1/4W (US, CND)
R592	1-249-429-11	CARBON 10K 5%	1/4W
R593	1-249-429-11	CARBON 10K 5%	1/4W
R594	1-249-429-11	CARBON 10K 5%	1/4W
R595	1-249-429-11	CARBON 10K 5%	1/4W
R597	1-249-429-11	CARBON 10K 5%	1/4W
R613	1-247-895-00	CARBON 470K 5%	1/4W
R614	1-249-437-11	CARBON 47K 5%	1/4W
R623	1-247-895-00	CARBON 470K 5%	1/4W
R624	1-249-437-11	CARBON 47K 5%	1/4W
R801	1-249-426-11	CARBON 5.6K 5%	1/4W
R803	1-249-425-11	CARBON 4.7K 5%	1/4W
R804	1-249-429-11	CARBON 10K 5%	1/4W
R911	1-249-425-11	CARBON 4.7K 5%	1/4W
R912	1-249-437-11	CARBON 47K 5%	1/4W
< VIBRATOR >			
X351	1-579-314-11	VIBRATOR, CRYSTAL (22.5792MHz)	
X513	1-781-174-21	VIBRATOR, CERAMIC (10MHz)	
*****			
*	A-4724-590-A	PANEL BOARD, COMPLETE *****	
*	4-216-341-01	HOLDER (FL)	
*	4-921-941-01	CUSHION (FL)	
< CAPACITOR >			
C701	1-126-153-11	ELECT 22uF 20%	6.3V
C760	1-164-159-11	CERAMIC 0.1uF	50V
C761	1-162-294-31	CERAMIC 0.001uF	10% 50V
C762	1-162-294-31	CERAMIC 0.001uF	10% 50V
C763	1-162-294-31	CERAMIC 0.001uF	10% 50V
C764	1-164-159-11	CERAMIC 0.1uF	50V
C765	1-126-153-11	ELECT 22uF 20%	6.3V
C766	1-164-159-11	CERAMIC 0.1uF	50V
C769	1-162-215-31	CERAMIC 47PF	5% 50V
< CONNECTOR >			
CNS701	1-778-449-11	CONNECTOR, FFC/FPC 19P	
* CNS702	1-565-481-11	CONNECTOR, BOARD TO BOARD 5P	
< LED >			
D741	8-719-046-44	LED SEL5221S (●)	
D742	8-719-046-43	LED SEL5421E-TP15 (▷)	
< FLUORESCENT INDICATOR TUBE >			
FL771	1-517-804-11	INDICATOR TUBE, FLUORESCENT	
< IC >			
IC761	8-759-426-98	IC MSM9202-02GS-K	
< TRANSISTOR >			
Q741	8-729-422-57	TRANSISTOR UN4111	
Q742	8-729-422-57	TRANSISTOR UN4111	

Ref. No.	Part No.	Description	Remark
Q767	8-729-900-74	TRANSISTOR DTC143TS	
< RESISTOR >			
R702	1-249-421-11	CARBON 2.2K 5%	1/4W
R703	1-247-843-11	CARBON 3.3K 5%	1/4W
R704	1-249-425-11	CARBON 4.7K 5%	1/4W
R705	1-249-429-11	CARBON 10K 5%	1/4W
R706	1-249-435-11	CARBON 33K 5%	1/4W
R712	1-249-421-11	CARBON 2.2K 5%	1/4W
R713	1-247-843-11	CARBON 3.3K 5%	1/4W
R714	1-249-425-11	CARBON 4.7K 5%	1/4W
R722	1-249-421-11	CARBON 2.2K 5%	1/4W
R723	1-247-843-11	CARBON 3.3K 5%	1/4W
R724	1-249-425-11	CARBON 4.7K 5%	1/4W
R725	1-249-429-11	CARBON 10K 5%	1/4W
R741	1-249-409-11	CARBON 220 5%	1/4W
R742	1-249-409-11	CARBON 220 5%	1/4W
R760	1-247-807-31	CARBON 100 5%	1/4W
R761	1-247-807-31	CARBON 100 5%	1/4W
R762	1-247-807-31	CARBON 100 5%	1/4W
R763	1-247-807-31	CARBON 100 5%	1/4W
R767	1-249-441-11	CARBON 100K 5%	1/4W
R769	1-247-843-11	CARBON 3.3K 5%	1/4W
< SWITCH >			
S701	1-762-875-21	SWITCH, KEYBOARD (● REC)	
S702	1-762-875-21	SWITCH, KEYBOARD (■)	
S703	1-762-875-21	SWITCH, KEYBOARD (▶▶)	
S704	1-762-875-21	SWITCH, KEYBOARD (◀◀)	
S705	1-762-875-21	SWITCH, KEYBOARD (▬▬)	
S706	1-762-875-21	SWITCH, KEYBOARD (▷)	
S711	1-762-875-21	SWITCH, KEYBOARD (MENU/NO)	
S712	1-762-875-21	SWITCH, KEYBOARD (YES)	
S713	1-475-139-11	ENCODER, ROTARY (◀◀ AMS ▶▶, PUSH ENTER)	
S714	1-762-875-21	SWITCH, KEYBOARD (CLEAR)	
S721	1-762-875-21	SWITCH, KEYBOARD (EJECT ≡)	
S722	1-762-875-21	SWITCH, KEYBOARD (PLAY MODE)	
S723	1-762-875-21	SWITCH, KEYBOARD (REPEAT)	
S724	1-762-875-21	SWITCH, KEYBOARD (SCROLL)	
S725	1-762-875-21	SWITCH, KEYBOARD (LEVEL/DISPLAY/CHAR)	
S731	1-571-427-11	SWITCH, SLIDE (INPUT)	
*****			
*	1-673-305-11	PANEL 2 BOARD *****	
< CAPACITOR >			
C781	1-124-584-00	ELECT 100uF 20%	10V
C782	1-162-306-11	CERAMIC 0.01uF	20% 16V
< CONNECTOR >			
* CNP702	1-569-799-11	PLUG, CONNECTOR 5P	
< LED >			
D751	8-719-046-44	LED SEL5221S (I/Ⓛ)	

Ref. No.	Part No.	Description	Remark
		< IC >	
IC781	8-749-013-92	IC GP1UC7X (H)	
		< TRANSISTOR >	
Q751	8-729-422-57	TRANSISTOR UN4111	
		< RESISTOR >	
R726	1-249-435-11	CARBON 33K 5% 1/4W	
R751	1-249-409-11	CARBON 220 5% 1/4W	
R781	1-249-401-11	CARBON 47 5% 1/4W	
R782	1-247-807-31	CARBON 100 5% 1/4W	
		< SWITCH >	
S726	1-762-875-21	SWITCH, KEYBOARD (I/⏻)	
*****			
*	1-668-111-11	SW BOARD	
		*****	
		< CONNECTOR >	
CN601	1-506-486-11	PIN, CONNECTOR 7P	
		< SWITCH >	
S601	1-572-126-21	SWITCH, PUSH (1 KEY) (REC POSITION)	
S602	1-572-126-21	SWITCH, PUSH (1 KEY) (PACK OUT)	
S604	1-771-264-11	SWITCH, PUSH (DETECTION)(1 KEY) (PB POSITION)	
*****			
*	1-673-306-11	TRANS BOARD	
		*****	
		< CAPACITOR >	
△ C901	1-113-920-11	CERAMIC 0.0022uF 20% 250V	
△ C902	1-113-920-11	CERAMIC 0.0022uF 20% 250V	
		< CONNECTOR >	
* CN901	1-580-230-11	PIN, CONNECTOR (PC BOARD) 2P	
		< LINE FILTER >	
△ LF901	1-411-547-11	FILTER, LINE	
		< RELAY >	
△ RY911	1-765-324-11	RELAY	
		< POWER TRANSFORMER >	
△ T901	1-433-702-11	TRANSFORMER, POWER (US, CND)	
△ T901	1-433-703-11	TRANSFORMER, POWER (AEP, UK)	
△ T901	1-433-704-11	TRANSFORMER, POWER (SP)	
△ T910	1-433-697-11	TRANSFORMER, POWER (US, CND)	
△ T910	1-433-698-11	TRANSFORMER, POWER (AEP, UK)	
△ T910	1-433-699-11	TRANSFORMER, POWER (SP)	
*****			

Ref. No.	Part No.	Description	Remark
		MISCELLANEOUS	
		*****	
9	1-790-510-11	WIRE (FLAT TYPE) (19 CORE)	
57	1-790-512-11	WIRE (FLAT TYPE) (21 CORE)	
58	1-790-513-11	WIRE (FLAT TYPE) (23 CORE)	
61	1-500-051-11	BEAD, FERRITE (WITH CASE)	
△ 63	1-696-586-21	CORD, POWER (UK)	
△ 63	1-777-071-31	CORD, POWER (AEP, SP)	
△ 63	1-783-531-31	CORD, POWER (US, CND)	
* 258	1-667-954-11	FLEXIBLE BOARD	
△ 260	8-583-028-02	OPTICAL PICK-UP KMS-260A/J1NP	
HR901	1-500-502-11	HEAD, OVER WRITE	
M101	A-4672-516-A	MOTOR ASSY, SPINDLE	
M102	A-4672-515-A	MOTOR ASSY, SLED	
M103	X-4949-670-1	MOTOR ASSY, LOADING	
S102	1-762-148-21	SWITCH, PUSH (2 KEY) (REFLECT DET, PROTECT DET)	
△ T901	1-433-697-11	TRANSFORMER, POWER (US, CND)	
△ T901	1-433-698-11	TRANSFORMER, POWER (AEP, UK)	
△ T901	1-433-699-11	TRANSFORMER, POWER (SP)	
*****			
		*****	
		HARDWARE LIST	
		*****	
#1	7-685-646-79	SCREW +BVTP 3X8 TYPE2 N-S	
#3	7-621-772-20	SCREW +B 2X5	
#4	7-621-772-40	SCREW +B 2X8	
#5	7-627-852-08	SCREW, PRECISION +P 1.7X2.5	
#6	7-685-533-19	SCREW +BTP 2.6X6 TYPE2 N-S	
#7	7-685-133-19	SCREW +P 2.6X6 TYPE2 NON-SLIT	
*****			
		ACCESSORIES & PACKING MATERIALS	
		*****	
1-418-270-11		REMOTE COMMANDER (RM-D30P)	
1-574-264-11		CORD, OPTICAL PLUG	
1-776-263-51		CORD, CONNECTION	
3-866-678-11		MANUAL, INSTRUCTION (ENGLISH)	
3-866-678-21		MANUAL, INSTRUCTION (FRENCH, SPANISH, PORTUGUESE) (CND, AEP)	
3-866-678-31		MANUAL, INSTRUCTION (GERMAN, DUTCH, SWEDISH, ITALIAN) (AEP)	
3-866-678-41		MANUAL, INSTRUCTION (CHINESE) (SP)	
4-981-643-11		COVER, BATTERY (for RM-D30P)	

The components identified by mark △ or dotted line with mark △ are critical for safety. Replace only with part number specified.	Les composants identifiés par une marque △ sont critiques pour la sécurité. Ne les remplacer que par une pièce portant le numéro spécifié.
--	--

